

Repair Effectiveness Studies on Impact Damaged Sandwich Composite Constructions

M. RAJU, C. RAJASEKHAR REDDY, M. R. NARASIMHA SWAMY AND G. GIRIDHAR
BMS College of Engineering, Bangalore

L. SRIKANTH, M. RAJENDRA PRAKASH AND R. M. V. G. K. RAO*
*Fibre Reinforced Plastics Division
National Aerospace Laboratories (NAL)
Bangalore-560 017, India*

ABSTRACT: Experimental studies were carried out using sandwich composite panel specimens, consisting of both polyurethane foam core (PUF) and aramid honeycomb core (Nomex) type constructions. These specimens were subjected to impact damage at energy levels ranging between 7.56 and 15.6J. A ply-drop-patching technique was employed to repair the impact damaged sandwich specimens. The undamaged (virgin), impact damaged, and repaired specimens were then subjected to flexural (four point bending) and edgewise compression tests and strength recoveries were measured to determine the efficacy of the repair technique employed. In flexure, strength recoveries of upto 97% in PUF core and 90% in honeycomb core sandwich specimens were realized after repair, whereas in compression, the corresponding values were upto 90% in PUF core and 88% in honeycomb core sandwich specimens. A repair effectiveness factor (R_{ef}) has been conceived and introduced to quantify the efficiency of the repair technique. Further, the repair quality was assessed using a simple NDT method prior to subjecting the sandwich specimens for destructive tests.

KEY WORDS: sandwich, impact damage, composite repair, repair efficiency.

INTRODUCTION

THE INCREASING USE of composites in both military and commercial aircraft requires the development of proven repair methods that restore the integrity of the damaged structure, with minimum degradation in its functional capability and weight addition. Further, the implementation of online repairs calls for simple procedures and gadgets to avoid excessive down time of the component. Therefore, continued and expanded use of composites critically depends on the development of both structurally adequate and economically feasible, repair techniques.

Presently, one of the main concerns of the composite aircraft industry is multiple delamination damage caused by accidental impacts such as bird hits, runway debris, battle damage, etc. The extent of damage dictates the choice between repair of the component and its total replacement. Repairs involving adhesively bonded patches are preferred for composites, because bonding produces no holes (for fasteners), thus eliminating regions of stress concentration. Ideally, the patch should be so designed and

*Author to whom correspondence should be addressed.

adhesively bonded to the parent laminate, so as to provide the most effective load transfer path across the repaired zone, and restore it as closely as possible to the status of the undamaged zone.

Thomson and Mouritz [1–3] carried out extensive studies on the degradation effects of impact damage on the mechanical properties of PVC foam core type sandwich beams through four-point bending and edgewise compression tests. Mines and Cheng [4] conducted compressive tests on low velocity impacted honeycomb core sandwich panels and the tests indicated that the residual strength decreased with increasing impact energy. Hart Smith's [5] tests on adhesive joints showed that stepped lap or scarf joint configurations give the strongest bonded joints and hence are employed for bonded patch repairs. Mahdi et al. [6] have presented the mechanical performance (four-point bending strength) of repaired honeycomb core composite sandwich beams, consisting of moulded prepreg skins and adhesive films, employing overlap and scarf repair schemes. Strength recovery of over 90% was recorded. Shah Khan and Grabovac [7] carried out studies on the effect of replacement-core plug geometry with a step-lap skin repair scheme, on the strength recovery under fatigue loading of foam core sandwich specimens.

Usage of ready to use prepreps and adhesive films has been limited to certain specific applications as they involve invariably more elaborate and often, if not always, more expensive approaches. On the other hand, for the majority of routine applications, damage zone repairs with wet-laminated composite patches (just in time prepreps) consisting of compatible fabric and resin systems are found to be useful in repairing of vacuum and resin injection moulded composite parts, thereby providing an inexpensive repair approach for applications such as the repair of battle damage [8].

This article is a result of efforts made to bring out a quantified effectiveness of an inexpensive field-friendly repair scheme based on a ply-drop-patching technique, for impact damaged sandwich panels, and its efficacy as applicable to both foam core and honeycomb core type RT-cured sandwich panel constructions.

EXPERIMENTAL DETAILS

Materials Used

The following materials were used in these studies:

1. E-Glass 2 × 2 twill bi-directional fabric of an areal density of 280 gsm (supplied by M/s. Arun Fabrics, Bangalore, India).
2. Epoxy resin LY556+ hardener HY951 – RT cure system (supplied by M/s. Vantico Ltd., Mumbai, India).
3. PU foam core of 30 mm thickness and 85 kg/m³ density (in-house developed).
4. Phenolic resin impregnated Aramid Nomex honeycomb core of 6.7 mm thickness (Hexcel HRH10) (supplied by M/s. Hexcel Corp., USA).

Test Specimen Preparation

Sandwich panels of 300 × 300 mm² consisted of three-ply GFRP skins on either side of the core as shown schematically in Figure 1. The skins were prepared by a wet lay-up process ensuring 0.65 fiber-weight fraction and vacuum-bonded to the core. The core along with the lay-up was cured at RT for 24 h followed by a post-curing at 80°C for 3 h.

of curvature of 12.7 mm and weighing 2.57 kg, was dropped from heights ranging from 400 to 600 mm delivering 7.56 to 15.6 J of impact energy to the sandwich panel specimens.

Flexural and Edgewise Compression Tests

The sandwich specimens were tested in an INSTRON 6025 universal testing machine at a cross-head speed of 0.5 mm/min, equipped with a data acquisition system, that was used to record the test data (load, deflection, etc.).

A schematic view of the flexural and edgewise compression specimen (after impact damage) under loading are as shown in Figure 3(a) and (b).

The flexural strength (σ_F) and edgewise compression strength (σ_C) of the sandwich specimens were calculated as per the following formulae:

$$\sigma_F = \frac{PL}{3t(d+c)b} \tag{1}$$

$$\sigma_C = \frac{P}{2tb} \tag{2}$$

where the terms in the above equations refer to those depicted in Figure 3(a) and (b).

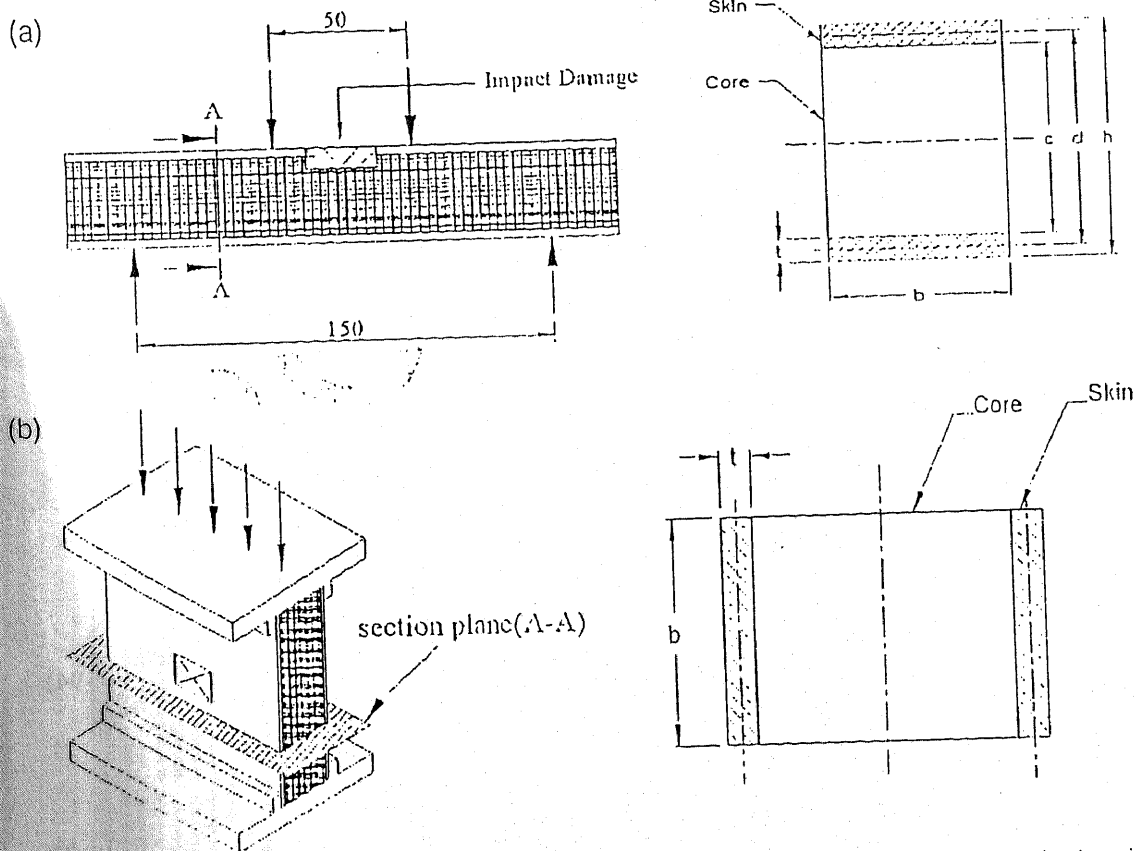

Figure 3. (a) A loaded flexural test specimen (damage on compression side) and (b) a loaded edgewise compression test specimen (damage on any side).

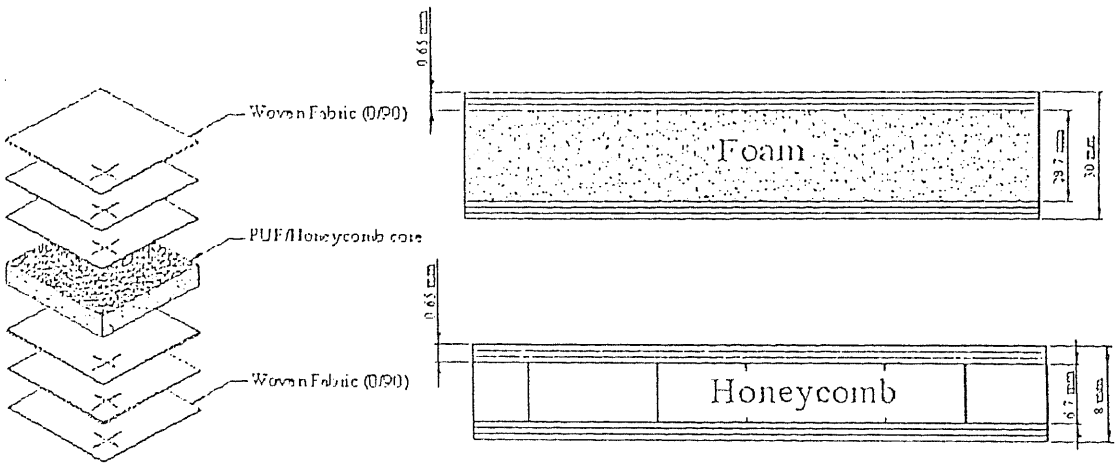

Figure 1. Schematic view of sandwich constructions.

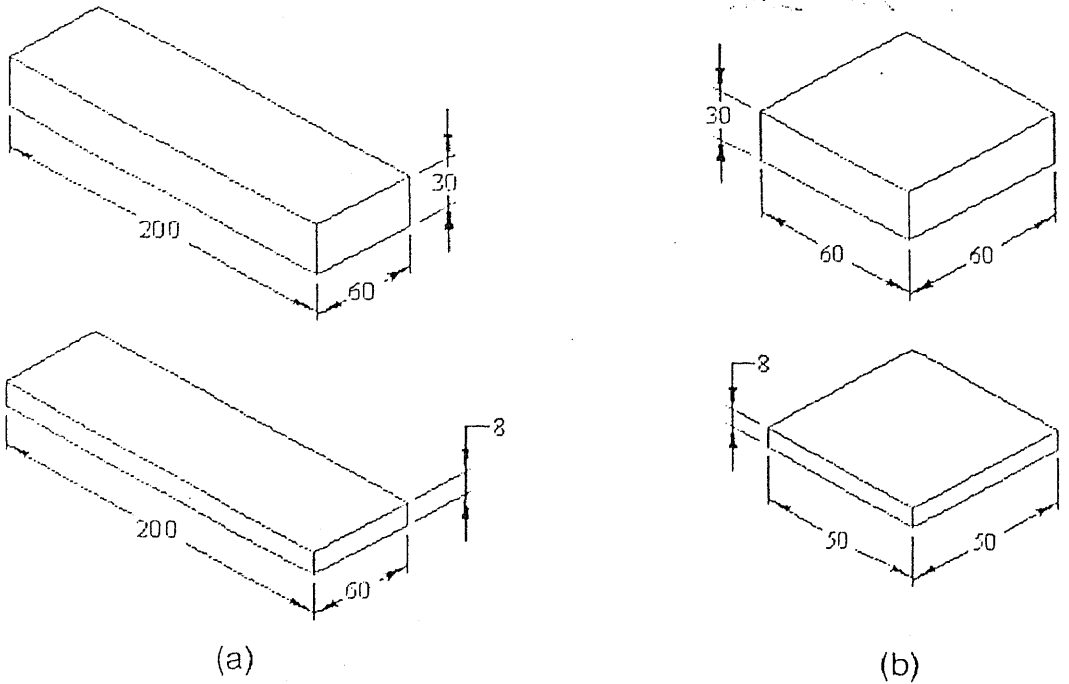

Figure 2. (a) Flexure test specimens and (b) edgewise compression test specimens.

The flexure (ASTM C 393) and edgewise compression specimens (ASTM C 364-94) prepared for these studies are as shown in Figure 2(a) and (b).

Impact-damage of Test Specimens

A series of drop weight impacts were carried out on the sandwich panels using an in-house developed apparatus [9], to conceptualize accidental impact damage caused due to tool drop, runway debris, etc. A hemispherical stainless steel striker (tip), with a radius

Repair Scheme

An in-house developed ply-drop-patch repair scheme was used for carrying out repairs on impact damaged specimens. This involved the use of staggered wet pre-preg layers vacuum-bonded onto a suitably prepared damage-zone. To assess the repair quality of specimens prior to the mechanical tests, a practicable Non-Destructive Test (NDT) was carried out by tapping the virgin and repaired sandwich specimens, using the woodpecker device (WP632, Mitsui Japan make) working on the principle of acoustic emission, which is capable of detecting and digitally indicating the presence of delaminations/debonds. The recovery of the woodpecker numbers in repaired specimens closer to those of virgin specimens is considered as an index of repair quality. Figures 4-7 present a pictorial view

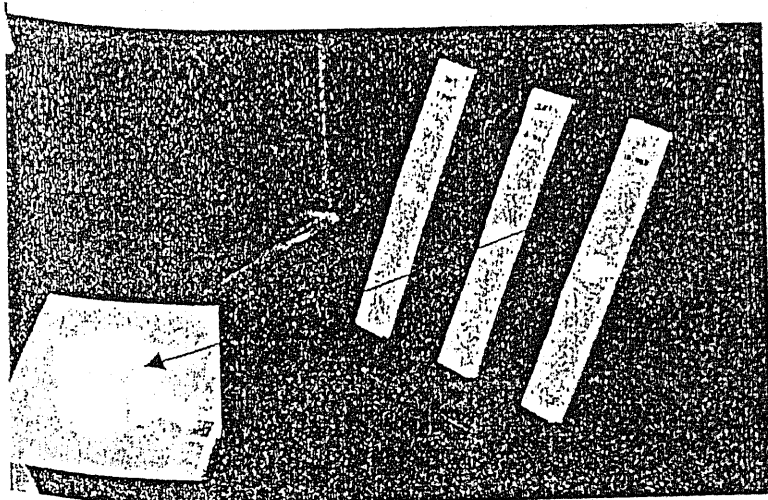

Figure 4. Impact damaged honeycomb sandwich flexural test specimens.

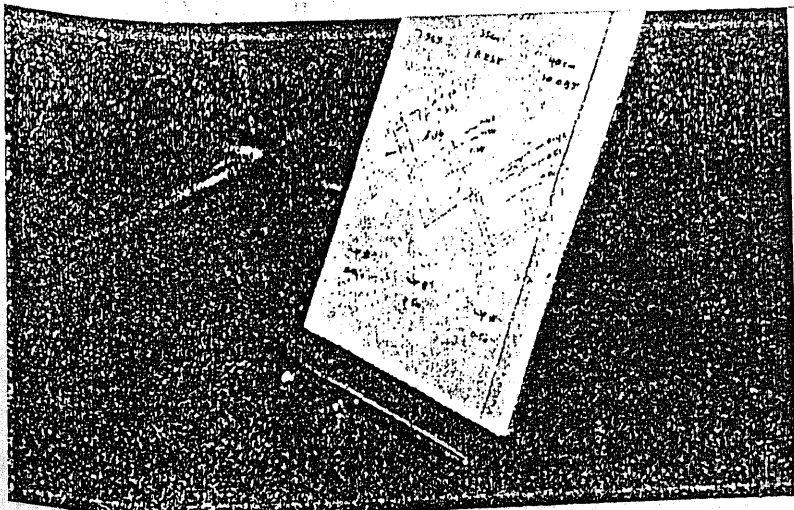

Figure 5. Repaired honeycomb sandwich flexural test specimens (woodpecker numbers marked).

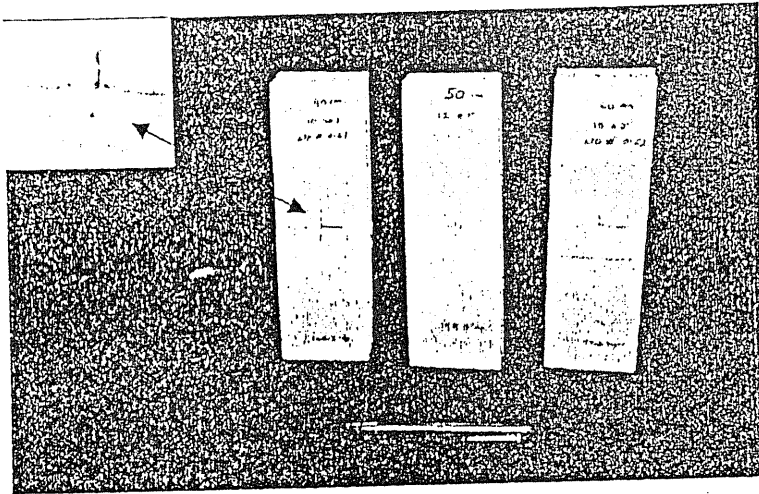

Figure 6. Impact damaged PUF core sandwich specimens subjected to flexural test.

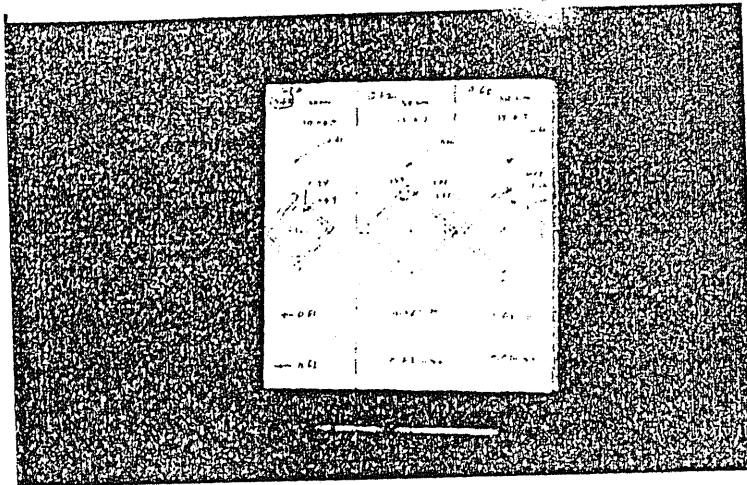

Figure 7. Repaired PUF core sandwich flexural test specimens (woodpecker numbers marked).

Table 1. NDT numbers indicating repair quality.

Sandwich construction	Woodpecker number	
	Virgin specimen	Repaired specimen
PUF	0.61	0.58–0.62
Honeycomb	0.54	0.54–0.60

of the damaged and repaired specimens of both types of sandwich constructions used in these studies.

The woodpecker numbers (Table 1), obtained both for the virgin specimens (reference value), and the repaired ones, indicate a good repair quality.

RESULTS AND DISCUSSION

The experimental results obtained, as average values of five test samples of sandwich constructions, at three different energy levels, are presented and discussed with respect to the following mechanical properties:

- Flexural strength by four-point bending test, with the damage present on the compression side of the test specimen.
- Edgewise compression strength, with damage present on one surface.

Based on the analysis of the above data, a repair effectiveness factor (R_{ef}), has been evolved and presented for both types of sandwich specimens, in order to quantify and assess the repair efficacy for this class of structural composites.

Flexural Strength of Sandwich Specimens

The virgin (σ_{FV} - reference value), residual (σ_{FD} - strength after damage), and recovered strength (σ_{FR} - strength after repair) of the sandwich specimens subjected to different impact energy levels are tabulated in Table 2.

Further, the percentage residual and recovered strength values, computed using the following expressions, are presented in Table 3.

$$\% \sigma_{FD} = \frac{\sigma_{FD}}{\sigma_{FV}} \times 100 \quad (3)$$

$$\% \sigma_{FR} = \frac{\sigma_{FR}}{\sigma_{FV}} \times 100 \quad (4)$$

From Table 3 it can be seen that, percent residual flexural strength of the honeycomb core sandwich specimen decreases to about 50%, but recoverable upto 90% of its virgin value. The corresponding values for the PUF core sandwich specimens are in the range 70-90% and 82-97%, of the virgin values. The percent residual and recovered flexural strengths are as plotted in column diagrams (Figures 8 and 9).

Edgewise Compression Strength of Sandwich Specimens

The virgin (σ_{CV} - reference value), residual (σ_{CD} - strength after damage), and recovered compression strength (σ_{CR} - strength after repair) of sandwich specimens for different energy levels are tabulated in Table 4.

Table 2. Virgin, residual, and recovered flexural strengths (MPa) of PUF and honeycomb core sandwich specimens.

Impact energy levels (J)	Honeycomb core sandwich specimens			PUF core sandwich specimens		
	σ_{FV}	σ_{FD}	σ_{FR}	σ_{FV}	σ_{FD}	σ_{FR}
Ref	148.8	-	-	37.44	-	-
7.56	-	71.8	133.9	-	-	-
8.82	-	61.11	125.7	-	-	-
10	-	53.46	121.9	-	34.27	36.42
12.8	-	-	-	-	30.57	34.28
15.6	-	-	-	-	25.98	31.05

Table 3. Percent residual and recovered flexural strengths of PUF and honeycomb core sandwich specimens.

Impact energy levels (J)	Honeycomb core sandwich specimens			PUF core sandwich specimens		
	σ_{FV}	σ_{FD}	σ_{FR}	σ_{FV}	σ_{FD}	σ_{FR}
Ref	100	—	—	100	—	—
7.56	—	49	90.32	—	—	—
8.82	—	45	84.7	—	—	—
10	—	42.2	82.3	—	91	97
12.8	—	—	—	—	81	91
15.6	—	—	—	—	69	82.5

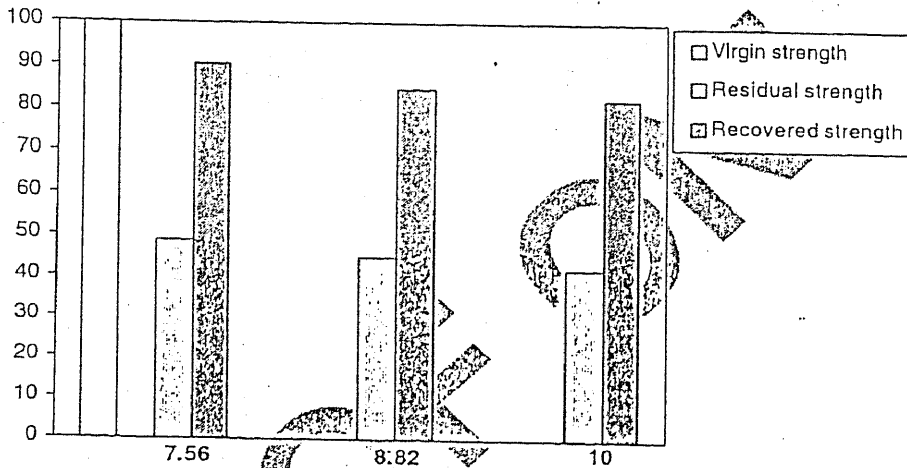

Figure 8. Percent residual and recovered flexural strengths of honeycomb core sandwich specimens. X-axis – impact energy; Y-axis – percent residual and recovered flexural strength.

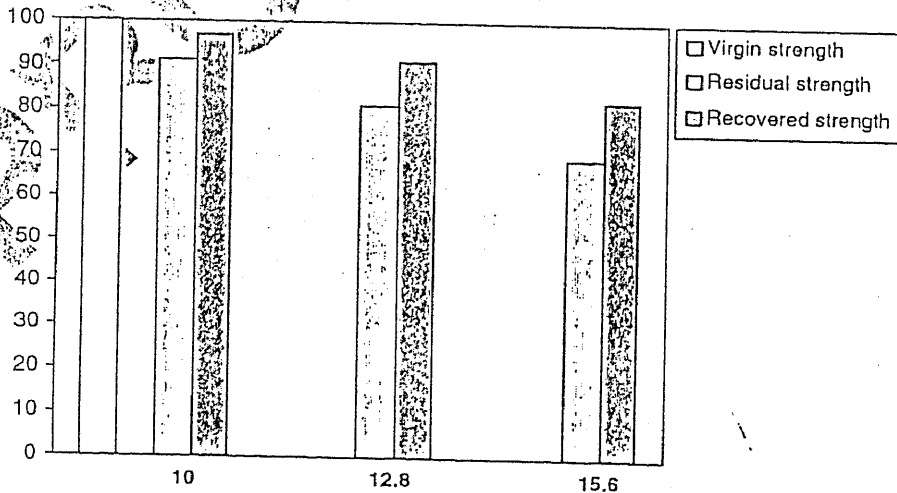

Figure 9. Percent residual and recovered flexural strengths of PUF core sandwich specimens. X-axis – impact energy; Y-axis – percent residual and recovered flexural strength.

Table 4. Virgin, residual, and recovered compression strengths (MPa) of PUF and honeycomb core sandwich specimens.

Impact energy levels (J)	Honeycomb core sandwich specimens			PUF core sandwich specimens		
	σ_{CV}	σ_{CD}	σ_{CR}	σ_{CV}	σ_{CD}	σ_{CR}
Ref	275.17	-	-	138.76	-	-
7.56	-	191.5	241.7	-	-	-
8.82	-	167.3	224.8	-	-	-
10	-	149.7	214.5	-	110	125.6
12.8	-	-	-	-	90.67	108.87
15.6	-	-	-	-	74.94	91.1

Table 5. Percent residual and recovered compression strengths of PUF and honeycomb core sandwich specimens.

Impact energy levels (J)	Honeycomb core sandwich specimens			PUF core sandwich specimens		
	σ_{CV}	σ_{CD}	σ_{CR}	σ_{CV}	σ_{CD}	σ_{CR}
Ref	100	-	-	100	-	-
7.56	-	69.63	87.83	-	-	-
8.82	-	59	80.5	-	-	-
10	-	54.4	78	-	79	90.5
12.8	-	-	-	-	65	78.5
15.6	-	-	-	-	54	66

Further, these residual and recovered compression strength properties, computed as a percentage of the virgin strength (σ_{CV}), using Expressions (3) and (4), are presented in Table 5.

From Table 5 it can be seen that, percent residual compression strength of the honeycomb core sandwich specimen decreases to about 50-70%, but is recoverable upto 80-90% of its virgin value. The corresponding values for the PUF core sandwich specimens are in the same range. The percent residual and recovered compression strengths are as plotted in Figures 10 and 11 (column diagrams).

Repair Effectiveness Factor (R_{ef})

To quantify the efficacy of the repair technique adopted, a repair effectiveness factor is introduced and defined as the ratio of the net strength recovered (difference of the recovered strength - σ_R and residual strength - σ_D) to the net strength lost (difference of virgin strength - σ_V and residual strength in a damaged specimen) and is as outlined below:

$$R_{ef} = \frac{\sigma_R - \sigma_D}{\sigma_V - \sigma_D} \quad (4)$$

The R_{ef} indicates the effectiveness of a repair technique on a scale of 0 and 1. When

$$\sigma_R = \sigma_V \quad (5)$$

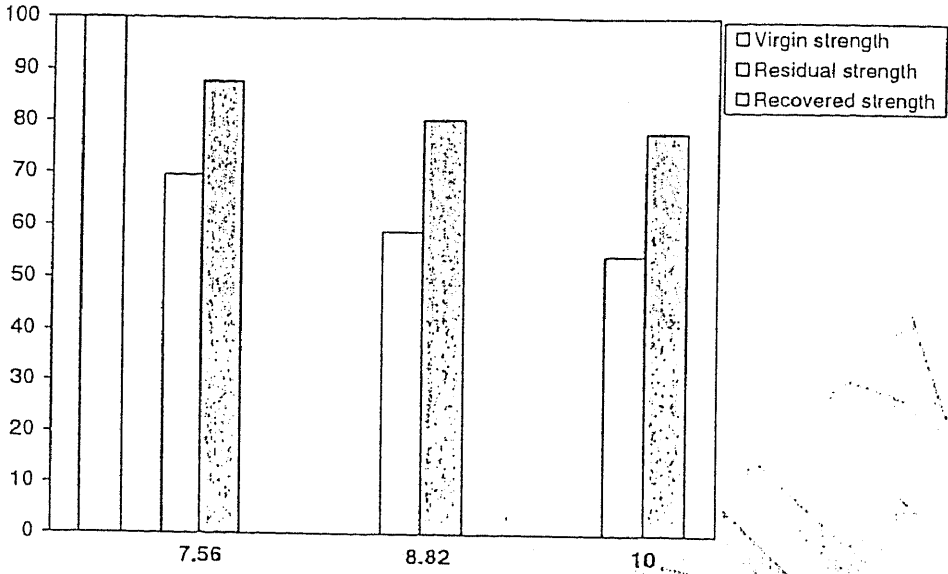

Figure 10. Percent residual and recovered compression strength of honeycomb core sandwich specimens. X-axis – impact energy; Y-axis – percent residual and recovered compression strength.

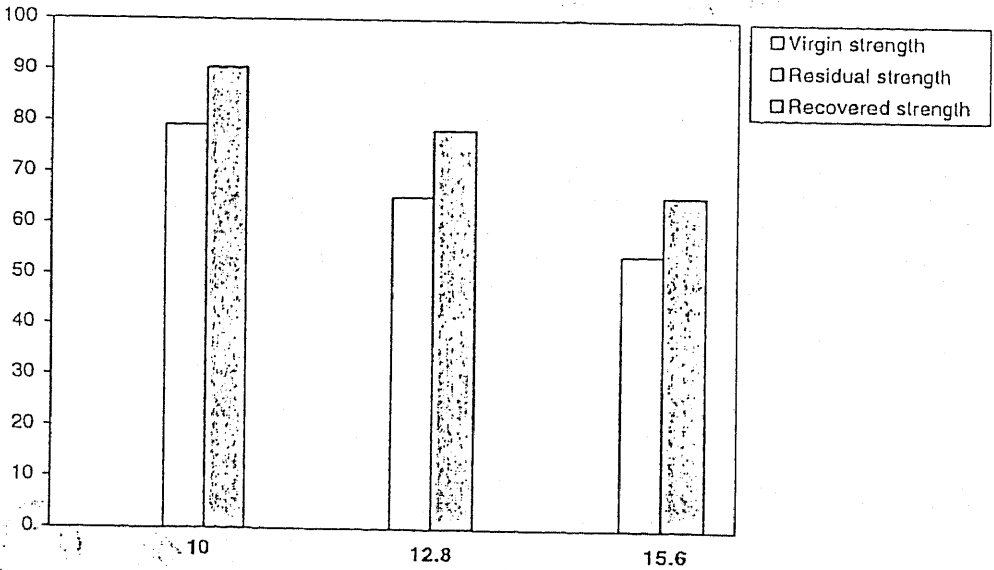

Figure 11. Percent residual and recovered compression strength of PUF core sandwich specimens. X-axis – impact energy; Y-axis – percent residual and recovered compression strength.

then, $R_{cr}=1$, indicating a total recovery of virgin strength due to repair. When

$$\sigma_R = \sigma_D \tag{6}$$

then, $R_{cr}=0$, indicating a zero recovery (an unsuccessful repair).

Comparison of R_{cr} values for both types of sandwich constructions are tabulated in Table 6 and presented in Figure 12.

Table 6. R_{ef} values for the repaired sandwich specimens.

Property	Impact energy		
	7.56 J	8.82 J	10 J
<i>Honeycomb core sandwich specimens</i>			
Flexure (Flx)	0.81	0.74	0.72
Edgewise compression (EC)	0.6	0.53	0.51
Property	Impact energy		
	10 J	12.8 J	15.6 J
<i>PUF core sandwich specimens</i>			
Flexure (Flx)	0.67	0.54	0.44
Edgewise compression (EC)	0.54	0.38	0.25

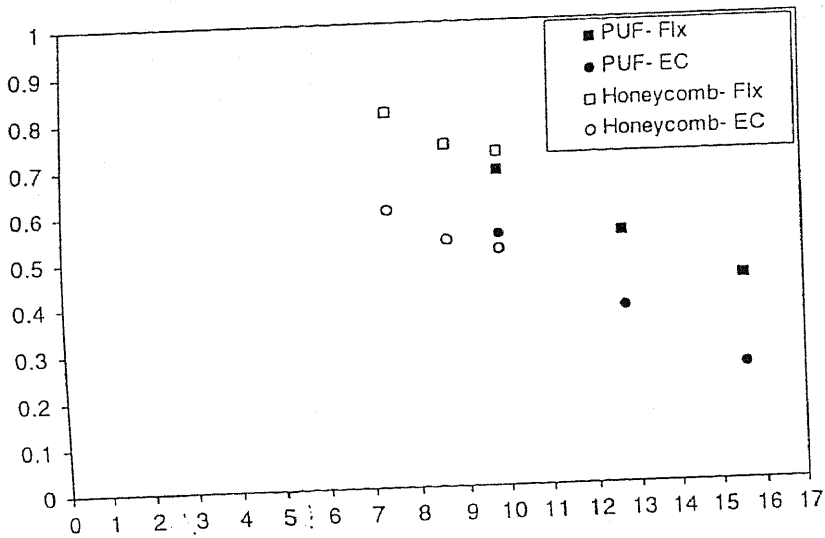

Figure 12. R_{ef} values for both types of sandwich constructions.

CONCLUSIONS

- The percent recovered flexural and edgewise compression strengths of the repaired specimens exhibited similar trends for both types of sandwich constructions.
- The overall recoveries in both types of sandwich specimens as quantified by R_{ef} values, lie in the range of 0.5–0.81 for the honeycomb core sandwich specimens and 0.25–0.67 in PUF core sandwich specimens. The R_{ef} values decrease with increasing impact energy levels. However, for both types of sandwich constructions the repair effectiveness in flexure is higher than that in edgewise compression loading.
- Both PUF and honeycomb core sandwich specimens showed comparable repair effectiveness factors (R_{ef}), when damaged at 10 J energy level.

ACKNOWLEDGMENT

The authors are thankful to Dr B. R. Pai, Director, National Aerospace Laboratories, Bangalore, for all the support during the investigation.

REFERENCES

1. Thomson, R. S. and Mouritz (1999). Compression, Flexure and Shear Properties of Sandwich Composites Containing Defects, *Composite Structures*, 44: 263-278.
2. Thomson, R. S., Shah Khan, M. Z. and Mouritz (1998). Shear Properties of a Sandwich Composites Containing Defects, *Composite Structures*, 42(2): 107-118.
3. Thomson, R. S. and Mouritz (1999). Skin Wrinkling in Impact Damaged Sandwich Composites, *Journal of Sandwich Structures and Materials*, 1(4): 299-322.
4. Mines and Cheng (1994). Response to Impact in Composites Containing Honeycomb, *Journal of Beijing University*.
5. Hart Smith, L. J. (1987). Design of Adhesively Bonded Joints, In: *Joining of Fibre Reinforced Materials*, pp. 271-311, Elsevier, Applied Science.
6. Mahdi, S., Kinloch, A. M. and Crisfield, M. A. (2003). Static Mechanical Performance of Repaired Sandwich Panels - Part I, *Journal of Sandwich Structures and Materials*, 5(2): 179-202.
7. Shah Khan, M. Z. and Grabovac, I. (2000). Repair of Damage to Marine Sandwich Structures Part II - Fatigue Loading, May 2000, DSTO-TN-275, DSTO Aeronautical and Maritime Research Laboratory, Melbourne, Australia (through internet).
8. Middleton, D. H. (1990). *Composite Aircraft Structures*, Longman and Scientific Company.
9. Kumar, C. R., Radhakrishna, K. and Rao, R. M. V. G. K. (2004). Post Curing Effects on Impact Behaviour of Composite Glass Epoxy Composite Laminates, *Journal of Reinforced Plastics and Composites* (in press).