

NASA TECHNICAL NOTE



NASA TN D-6354

2.1

NASA TN D-6354



LOAN COPY: RETURN TO
AFWL (DOGL)
KIRTLAND AFB, N. M.

RESONANCE TUBE IGNITION OF HYDROGEN-OXYGEN MIXTURES

by Bert R. Phillips and Albert J. Pavli

Lewis Research Center

Cleveland, Ohio 44135



0132861

1. Report No. NASA TN D-6354	2. Government Accession No.	3. Recipient's Catalog No.	
4. Title and Subtitle RESONANCE TUBE IGNITION OF HYDROGEN-OXYGEN MIXTURES		5. Report Date May 1971	6. Performing Organization Code
7. Author(s) Bert R. Phillips and Albert J. Pavli		8. Performing Organization Report No. E-6122	
9. Performing Organization Name and Address Lewis Research Center National Aeronautics and Space Administration Cleveland, Ohio 44135		10. Work Unit No. 731-12	11. Contract or Grant No.
12. Sponsoring Agency Name and Address National Aeronautics and Space Administration Washington, D. C. 20546		13. Type of Report and Period Covered Technical Note	
15. Supplementary Notes		14. Sponsoring Agency Code	
16. Abstract <p>The work reported herein was intended to lay the groundwork for the design and demonstration of a practical rocket engine igniter; significant progress has been shown. A method was found to render the system independent of ambient pressures by enclosing the nozzle gap in a can. The effects of many variables were determined, resulting in an "optimized" configuration which could ignite a 70° F (294 K) hydrogen-oxygen mixture in 0.13 second with 35-psia (241-kN/m²) propellant supply pressure. No ignitions were obtained with gases colder than -265° F (108 K). At -265° F (108 K), the ignition lag was 20 times greater than at 70° F (294 K) (10 sec as compared to 0.5 sec).</p>			
17. Key Words (Suggested by Author(s)) Resonance tube Resonance tube ignitor Resonance ignition Hydrogen-oxygen ignition		18. Distribution Statement Unclassified - unlimited	
19. Security Classif. (of this report) Unclassified	20. Security Classif. (of this page) Unclassified	21. No. of Pages 32	22. Price* \$3.00

CONTENTS

	Page
SUMMARY	1
INTRODUCTION	1
BACKGROUND	3
APPARATUS	6
RESULTS AND DISCUSSION	10
Parameters Influencing Resonance Heating	11
Effect of nozzle-cavity gap	11
Effect of nozzle pressure and nozzle pressure/ambient pressure ratio	13
Effect of nozzle diameter	15
Effect of nozzle expansion area ratio	15
Effect of trips	16
Effect of tube materials	17
Effect of cavity depth	18
Effect of tube shape	20
Effect of gas composition	22
Determining the most suitable igniter configuration	23
Parameters that Influence Ignition	23
Effect of nozzle pressure	24
Effect of mixture ratio	24
Effect of propellant inlet temperature	26
SUMMARY OF RESULTS	29
REFERENCES	30

RESONANCE TUBE IGNITION OF HYDROGEN-OXYGEN MIXTURES

by Bert R. Phillips and Albert J. Pavli

Lewis Research Center

SUMMARY

The ability of a resonance tube to produce ignition of hydrogen-oxygen mixtures was first demonstrated at room temperature by E. W. Conrad and A. J. Pavli of Lewis, thereby confirming its potential as a passive igniter for hydrogen-oxygen rocket engines. The work reported herein was intended to lay the groundwork for the design and demonstration of a practical engine igniter, and significant progress has been shown. A method was found, for example, to render the system independent of ambient pressures; namely, by enclosing the nozzle gap in a can. The effects of many variables were determined, resulting in an 'optimized' configuration which could ignite a 70° F (294 K) hydrogen-oxygen mixture in 0.13 second with 35-psia (241-kN/m²) propellant supply pressure. More precise optimization is certainly possible and could likely yield some improvement. Although reliable ignition was obtained with warm (70° F, 294 K) gas, such was not the case with cold gas. No ignitions were obtained with gases colder than -265° F (108 K). At -265° F (108 K), the ignition lag was 20 times greater than at 70° F (294 K), 10 seconds as compared to 0.5 second). There is much room for ingenuity in overcoming this remaining area of difficulty and it is believed that the results shown warrant further effort.

INTRODUCTION

The successful use of hydrogen and oxygen as propellants for rocket engines has been well documented in the literature. Examples of vehicle engines that use hydrogen and oxygen are the Centaur RL-10 and the Saturn J-2. In both of these stages, propellant ignition in the rocket engines is achieved by an electric spark system and, to date, the problems with these ignition systems have not precluded their use.

A new generation of vehicle stages is currently under study that also will use hydrogen and oxygen as propellants. The new stages, however, are required to be reusable indefinitely, with a premium placed on reliability and durability of all the systems

involved. The electric spark systems have performed satisfactorily in general; however, there are still the problems of wiring isolation, system complexity, and high-frequency electrical interference. The new emphasis on reliability and durability suggests that other methods of ignition be investigated.

The obvious method for igniting a combustible mixture is to apply sufficient heat until such time as the ignition temperature is reached. The thermal ignition limits for H_2-O_2 mixtures are presented in reference 1. According to that reference, ignition of a stoichiometric H_2-O_2 mixture will occur when the gases are heated to approximately $1000^{\circ} F$ ($811 K$).

The logical next step was to search for a simple, reliable, and rapidly acting device for heating gases to $1000^{\circ} F$ ($811 K$) or higher. The resonance tube (fig. 1) is such a de-

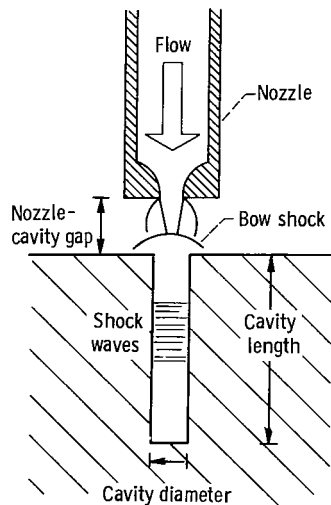

Figure 1. - Simple resonance tube.

vice. It operates by trapping a small quantity of high-pressure gas and passing a succession of shock waves through the trapped gas, heating it to high temperatures. Resonance tube heating has been investigated for some time. Of note is the work of Sprenger (ref. 2), where temperatures in excess of $1800^{\circ} F$ ($1265 K$) were obtained with room-temperature air.

The use of a vacuum-jacketed resonance tube to obtain ignition of a stoichiometric mixture of hydrogen and oxygen was reported by Conrad and Pavli (ref. 3). In that study, although the ignition destroyed the resonance tube, the success justified further investigation reported herein with the objective of obtaining a practical rocket engine igniter. Based on the results of references 2 and 3, the variables that affect resonance heating are the size and shape of the nozzle and resonance tube, the thermodynamic state of the gas, and the cavity material.

The procedure of the present study was to evaluate first the effects of the configuration variables on the resonant heating. The most suitable configuration was then used to study the effects of gas pressure, temperature, and composition on the ignition process. The effort was limited to aligned circular nozzles and tubes. A list of the parameters is given below:

- (1) Nozzle pressure, 0 to 100 psia (0 to 689 kN/m²)
- (2) Gas supply temperature, 70^o to -265^o F (294 to 108 K)
- (3) Gap between nozzle and cavity, up to 1 inch (2.54 cm)
- (4) Nozzle diameters, 0.15 to 0.30 inch (0.38 to 0.76 cm)
- (5) Resonator cavity diameter, 0.25 inch (0.635 cm)
- (6) Cavity shape, right cylindrical or tapered
- (7) Cavity depth, 0 to $7\frac{7}{16}$ inches (0 to 19 cm)
- (8) Cavity materials - brass, pyrolytic graphite, asbestos composites, etc.
- (9) Ambient pressure, 14.7 to 0.07 psia (101 to 0.48 kN/m²)
- (10) Gases - N₂, H₂, H₂-O₂ mixtures

The nozzles are described in the section APPARATUS.

The effects of the variables on the resonance heating were evaluated either by measuring the steady-state temperature at the base of the cavity or by measuring the peak amplitude of the pressure waves at the base of the cavity. The rationale for measuring the pressure waves is explained in the section BACKGROUND. The ignition process was evaluated by measuring the time lag between the start of temperature rise and ignition.

The experimental program was conducted at the Rocket Research Laboratory of the Lewis Research Center between February 1969 and July 1970.

BACKGROUND

To understand why some of the variables mentioned have an effect on the resonance heating and why the cavity-base pressure wave amplitude is a measure of the heating, it is necessary to study the resonance heating process in more detail. Resonance heating has been the subject of a great deal of experimental and analytical effort. The phenomenon was overlooked during the initial experiments of Hartman (ref. 4), who was interested in the resonance tube as a noise source. Subsequent investigations, particularly those of Sprenger (ref. 2), Thompson (ref. 5), and Kang (ref. 6) have emphasized the effectiveness of resonance tube heating as a simple way of obtaining a very small quantity of very hot gas. The essential features of the resonance tube are shown in figure 1. There is the nozzle and a cavity into which the sonic or supersonic jet flow is directed. At any one of several nozzle-cavity spacings, intense sound is radiated from the tube. Corresponding to the intense sound, the gas temperature at the base of the cavity is in-

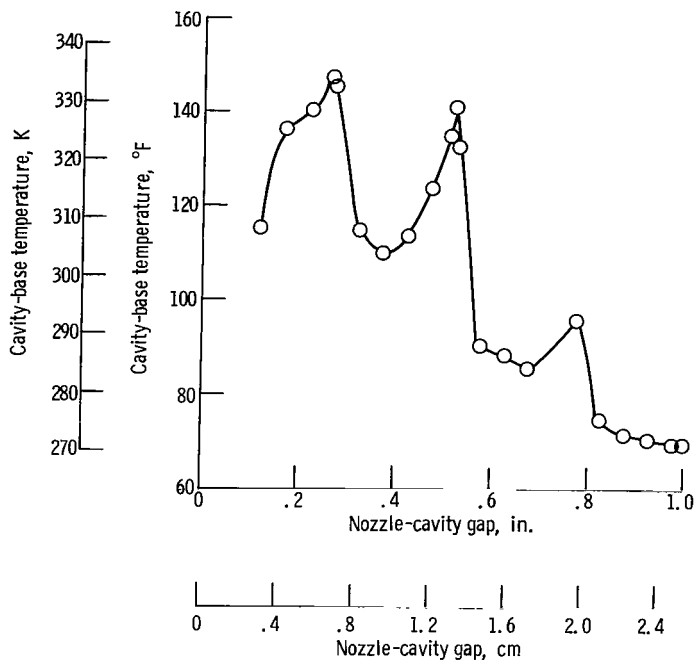

Figure 2. - Cavity-base temperature as function of nozzle-cavity gap. Brass cylindrical resonance tube; tube diameter, 0.25 inch (0.635 cm); cavity depth, 2.93 inches (7.442 cm); nozzle diameter, 0.20 inch (0.508 cm); nitrogen gas; nozzle pressure, 74 psia (510 kN/m²); ambient pressure, 14.3 psia (98.6 kN/m²).

creased far in excess of the gas stagnation temperature. A typical example of the variation of the cavity-base temperature as a function of nozzle-cavity gap is shown in figure 2. As shown in the figure, peaks in temperature were observed as nozzle-cavity gap was increased. Generally, the magnitude of these peaks decreased as nozzle-cavity gap was increased.

To understand the mechanism by which resonance heating occurs, it is necessary to study the driving jet flow. Taking the available literature into account, we may confine attention to a simple periodic underexpanded jet. A schlieren photograph and a sketch of a typical jet, together with the associated stagnation pressure variation, are shown in figure 3. If a blunt body with a cavity is placed within the jet flow field, a detached shock will form around it. The detached shock will be stable at a fixed position from the blunt body, as in figure 1. As the nozzle and flow field are adjusted relative to the blunt body and its associated shock, there will be regions in which the detached shock will oscillate. This is a resonant condition. These regions correspond to the unstable zones shown in figure 3, where the stagnation pressure rises with increasing distance from the nozzle. Compression or shock waves are detached from the oscillating bow shock and travel down the resonance tube. Reflecting off the cavity base, they couple with and reinforce the oscillating bow shock. Thus, there will be compression or shock waves oscillating up and down within the cavity. The period of the internal shock oscillations will be a function of

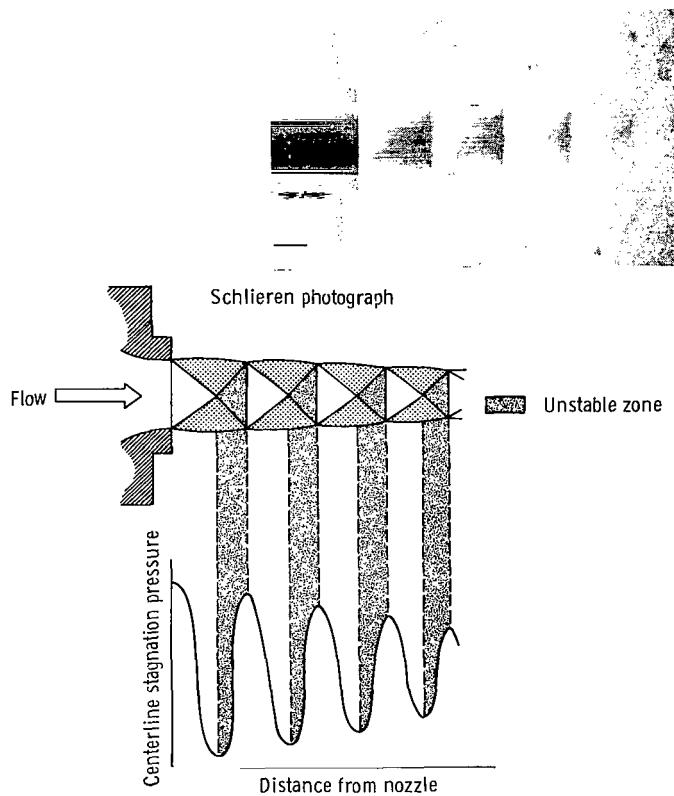

Figure 3. - Typical variation of stagnation pressure in an underexpanded choked jet.

the axial path length of the shock waves, generally of the order of the depth of the cavity. The key to the heating concept is that some of the gas that is trapped within the tube and heated by the first cycle of shock passages will remain in the tube for the second cycle of shock passages, and so on. Thus, the strength and frequency (work done) of the shock waves within the cavity will determine the heating of the indigenous gas. It can be seen that adjusting the cavity relative to the underexpanded jet will produce the variation of temperature shown in figure 2, with the peaks in temperature corresponding to the location of the resonating zones of figure 3. The position of the shocks relative to the nozzle is controlled by the ratio of nozzle pressure to ambient pressure, the specific-heat ratio of the gas, the nozzle diameter, and the nozzle contour. Thus, the oscillations are induced at critical values of the nozzle-cavity gas; and the shock-wave pressures and temperatures, in turn, are functions of size, geometry, material, and thermal characteristics.

It was necessary to experimentally vary the parameters and measure the variations in the shock strengths and gas temperatures since no satisfactory model has been offered, to date, to analytically predict the temperature as a function of the many variables.

APPARATUS

The experimental apparatus can be divided into distinct areas: The peripheral hardware which provides for the variation of positions, flows, supply pressures, etc.; the nozzles used to provide the jet flows; and the various cavities tested. A schematic of the flow system used for the tests is shown in figure 4. The variable-area orifices were pro-

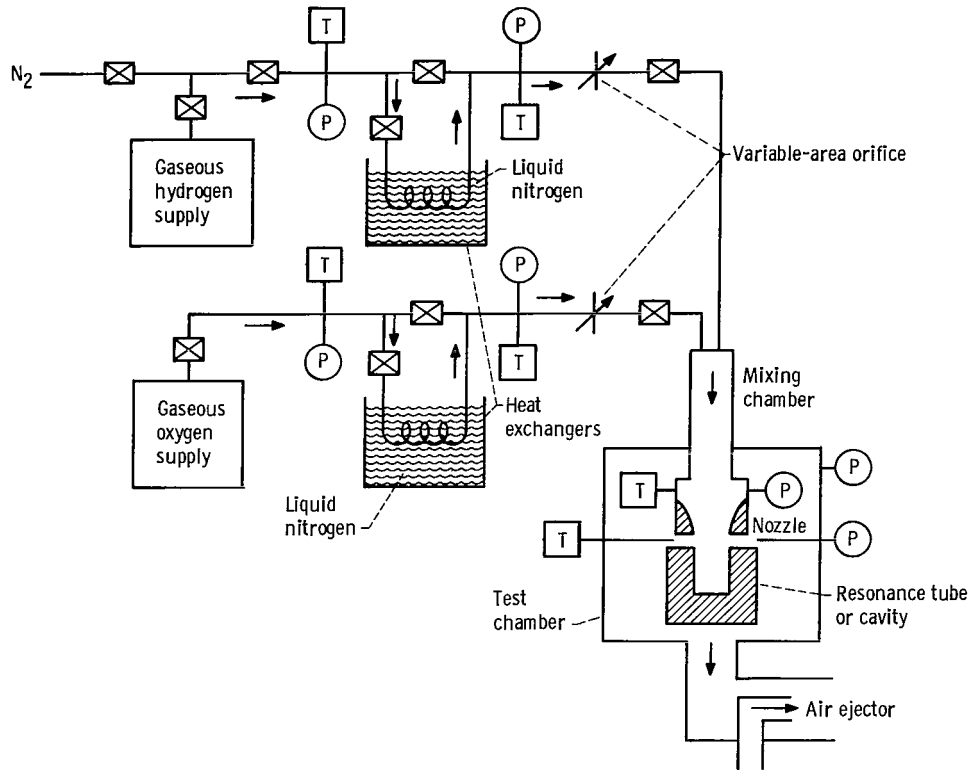

Figure 4. - Schematic of gas flow system.

vided so that the pressures of the two propellants delivered to the nozzle could be matched regardless of the mixture ratio. The temperature conditioners controlled the propellant temperatures by immersing the flow lines in baths of liquid nitrogen. A two-stage air ejector maintained the desired ambient pressure in the test chamber from 14.7 to 0.07 psia (101 to 0.48 kN/m^2).

In addition to the flow system, it was possible to view the area around the nozzle through schlieren optics to obtain information on the underexpanded jet flow.

The converging nozzles used in the test were fabricated from brass and had an internal curvature as indicated by the detail shown in figure 5. Some attempts were made to enhance the performance and broaden the operating range by adding nozzle expansion sec-

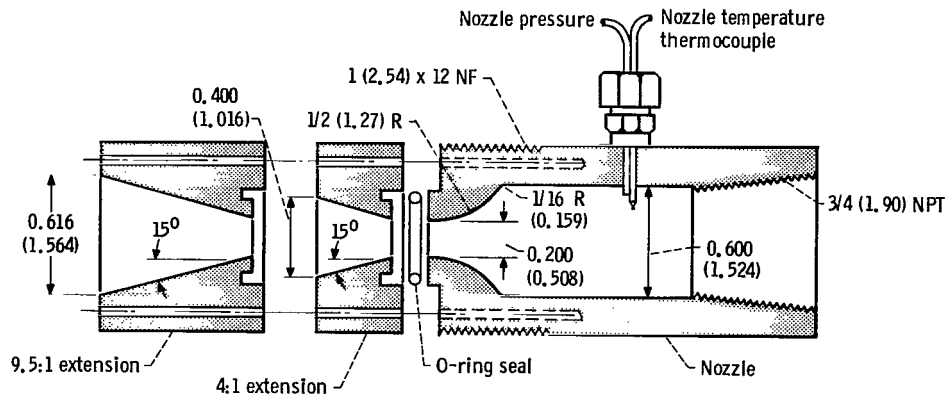
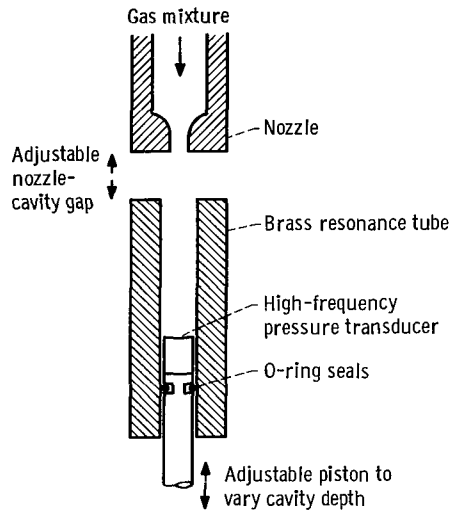

Figure 5. - Detail of nozzle and nozzle extensions. Dimensions are in inches (cm).

tions which provided supersonic jet flow. In addition to the nozzle extensions, some experiments were made with a thin (1/32 in., 0.079 cm) wire stretched across the cavity at varying distances from the mouth. These wires were intended to serve as trips to increase the operating pressure ratio range of the oscillations for a fixed gap (as suggested in ref. 2).

The resonance cavities in which the oscillatory wave pressures at the base of the cavity and the cavity-base temperatures were measured are shown in figures 6(a) and (b). Both the nozzle-cavity gap and the cavity depth were remotely adjustable by means of mechanical actuators. To allow for smooth motion of the cavity piston without permitting leakage, O-ring seals were provided. The pressure transducer used had a response that was flat to 10 kilohertz. The iron-constantan, exposed-junction thermocouple used to measure temperature was thermally insulated from the piston to give the gas temperature. The thermocouple was calibrated only to 1000⁰ F (811 K) since this was the region of principal interest.

As has been discussed, the jet flow field between the nozzle and the mouth of the resonance tube has a marked effect on the resonance heating process. Since an ignition system will have to operate independently of the altitude, a method was necessary to control the ambient conditions. The method conceived was to enclose the region between the nozzle and the resonance tube with a metal shell or can. The can was provided with orifices for the gas to flow through. Both the nozzle and the can orifices were choked so that the ratio of nozzle pressure to can pressure was determined by the ratio of nozzle orifice area to can orifice area independently of changes in altitude. This configuration with a fixed gap and a fixed resonance tube length is shown in figures 7(a) and (b). The ratio of nozzle pressure to can pressure was controlled by the diameter of the can orifices indicated. The ignition was sensed by the thermocouple in the can.



(a) Wave-amplitude-measuring apparatus.

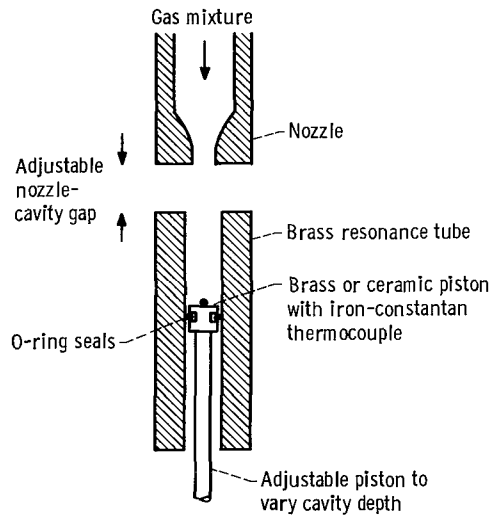

(b) Temperature-measuring apparatus.

Figure 6. - Apparatus for measuring cavity-base wave amplitude and temperature.

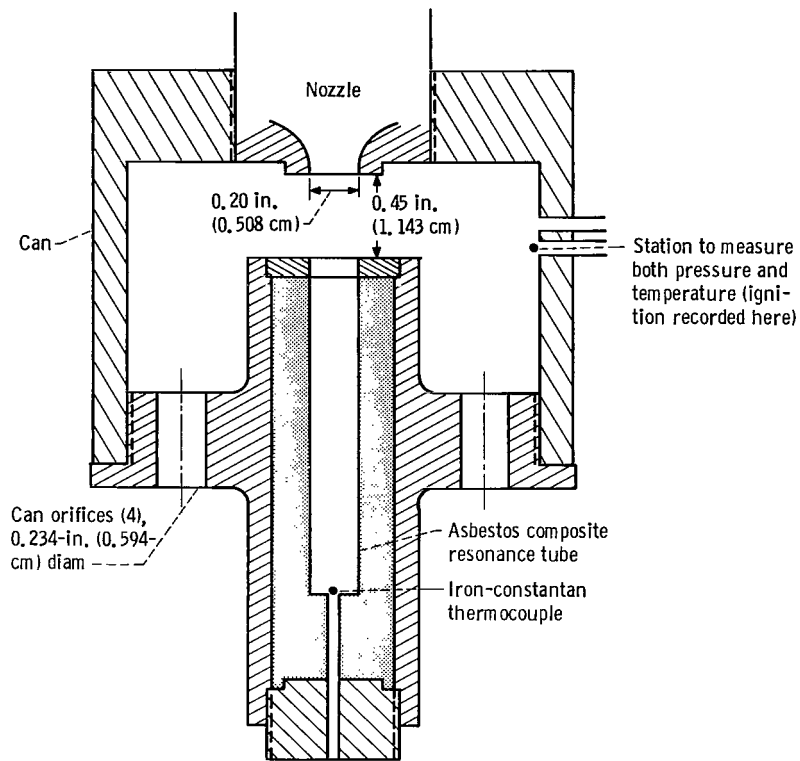

(a) Detail.

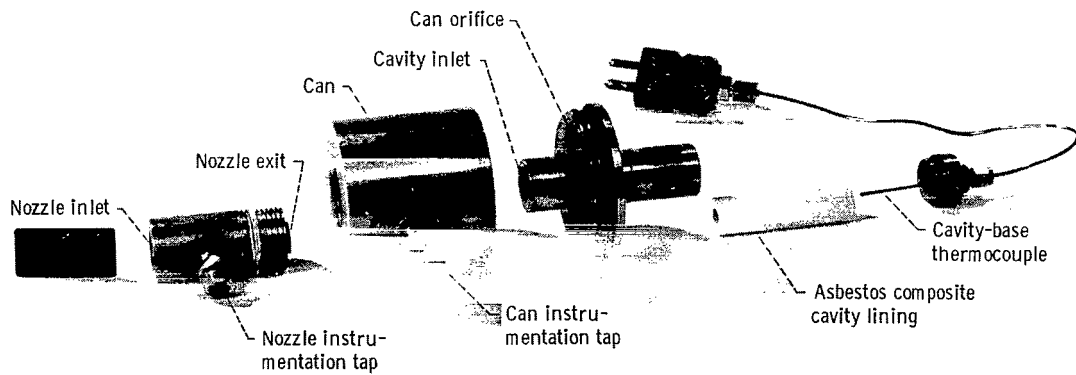

C-70-2071

(b) Disassembled fixed-gap igniter.

Figure 7. - Fixed-pressure-ratio, fixed-gap resonance igniter. Ratio of nozzle pressure to can pressure, 4.5.

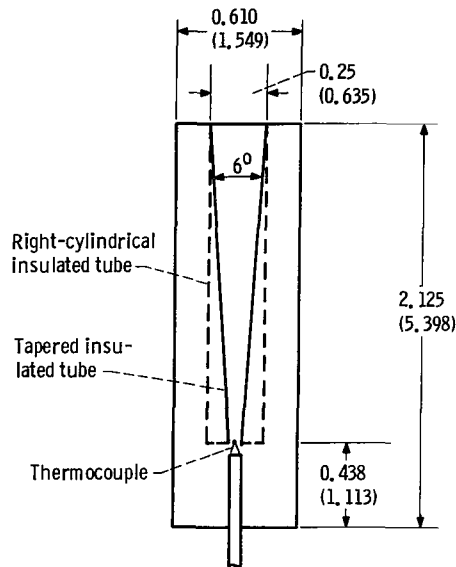

Figure 8. - Resonance cavity detail. Dimensions are in inches (cm).

The resonance tubes used to study ignition are shown in figure 8. Both the tapered and right-cylindrical shapes were evaluated with the thermocouple at the base of the cavity. To minimize heat loss to the apparatus, these tubes were constructed of commercially available asbestos composites with a thermal conductivity of approximately 0.245 joule per meter per second per K and capable of withstanding temperatures up to 1200⁰ to 1400⁰ F (922 to 1034 K).

RESULTS AND DISCUSSION

The experimental program was intended to evaluate the effects of the variables mentioned previously on the resonance heating, and to evaluate the effects of nozzle pressure, mixture ratio, and propellant supply temperature on ignition.

In examining the effects of the variables on resonance heating, the parameters were evaluated by measuring either cavity-base pressure oscillation amplitudes or cavity-base temperatures. In examining the effects on ignition, the parameters were evaluated by measuring the ignition lag (i. e. , time from start of heat generation to ignition).

Parameters Influencing Resonance Heating

Effect of nozzle-cavity gap. - As noted earlier in the background section, resonance heating will occur when the bow shock in front of the mouth of the resonance tube is located within one of the unstable zones of the jet flow field. It is thus of interest to determine the position of the unstable zones. It was found that the shock structure remains relatively constant regardless of whether a resonance cavity is present; and therefore, for simplicity, a free jet was studied. A series of nozzles of various diameters were flowed at various values of nozzle and ambient pressures, and schlieren photographs along with axial stagnation pressure surveys of the jet flow structure were taken. A typical photograph is shown in figure 3. From these photographs, the distance from the nozzle to the first cell boundary was measured. This distance, divided by the nozzle diameter, was plotted as a function of the nozzle pressure/ambient pressure ratio. The result is shown in figure 9. The single curve represents the data from four nozzle diameters and nozzle

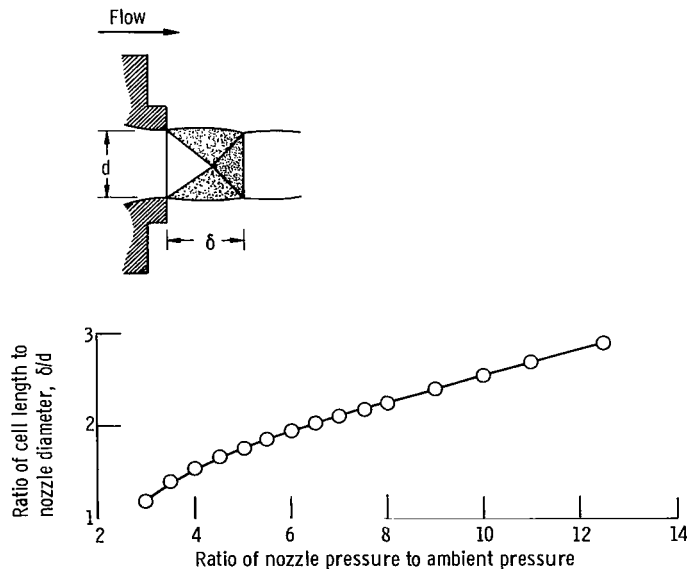

Figure 9. - Variation of position of first cell boundary as function of ratio of nozzle pressure to ambient pressure. Data taken with gaseous nitrogen at 45 and 90 psia (310 and 620 kN/m²).

pressures of 45 to 90 psia (310 to 620 kN/m²). It can be seen that the location of the unstable zone, as indicated by cell length, increases with increasing nozzle pressure ratio. The resonant heating can now be examined as a function of nozzle-cavity gap and, therefore, with regard to the coupling of the bow shock with the unstable zones in the shock structure. This is done by measuring the cavity-base temperature as a function of nozzle-cavity gap.

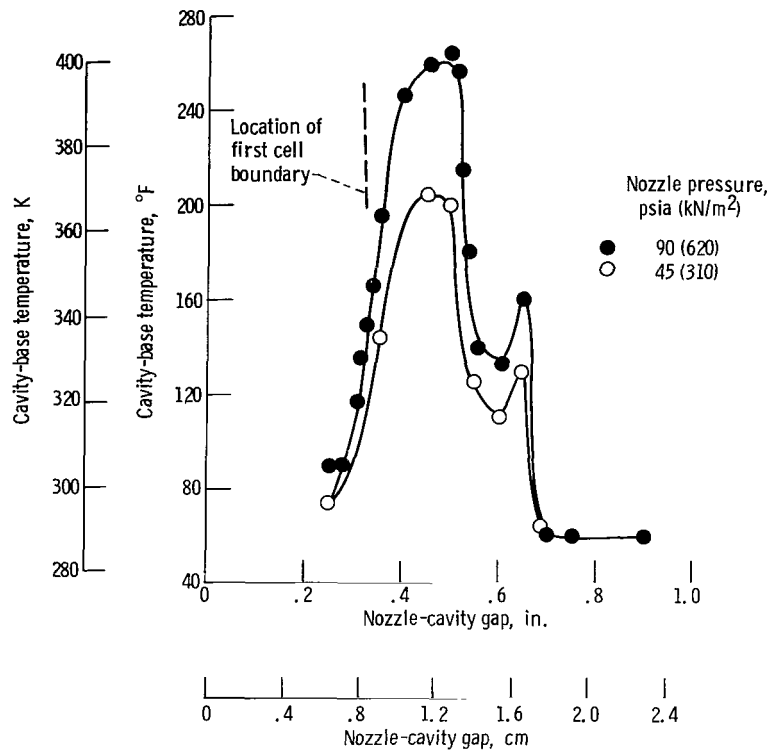

Figure 10. - Effect of nozzle-cavity gap on cavity-base temperature. Nozzle pressures, 45 and 90 psia (310 and 620 kN/m²); cavity depth, 3.35 inches (8.5 cm); nozzle diameter, 0.20 inch (0.508 cm); cylindrical brass tube 0.25 inch (0.635 cm) in diameter with ceramic piston; nozzle pressure to ambient pressure ratio, 4.25; gaseous nitrogen.

The configuration was a cylindrical brass resonance tube 0.25 inch (0.635 cm) in diameter with a ceramic piston (see fig. 7(b)). For each nozzle pressure chosen, the tank pressure was adjusted to give the desired nozzle pressure/ambient pressure ratio. The results of a typical cavity temperature test are shown in figure 10. The peak cavity-base temperatures were recorded at a nozzle-cavity gap of 0.45 inch (1.14 cm) for both 45 and 90 psia (310 and 620 kN/m²). For comparison, the position of the cell boundary for a free jet is superimposed on this figure. Thus, the temperature maxima occur at slightly greater gaps than the free-jet cell boundaries, as was expected since the bow shock stands out some distance from the resonance cavity entrance.

Continuing the experiments with various other nozzle diameters and pressure ratios, the nozzle gaps corresponding to temperature peaks were measured. The results, normalized by the nozzle diameters, are shown in figure 11. The free-jet cell boundary

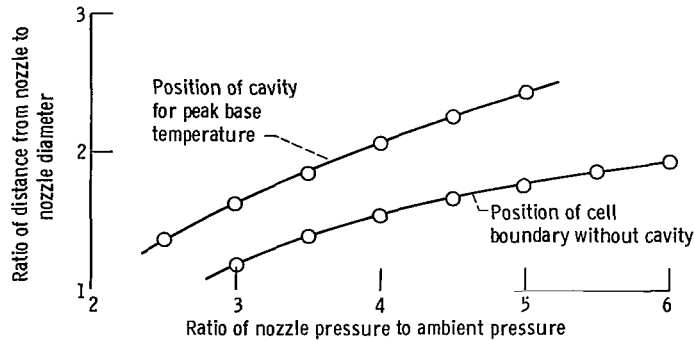

Figure 11. - Normalized cell boundary position and nozzle-cavity gap for peak cavity-base temperature as function of ratio of nozzle pressure to ambient pressure. Nozzle pressure, 45 psia (310 kN/m²); cylindrical brass resonance tube 0.25 inch (0.635 cm) in diameter and 3.35 inches (8.5 cm) in depth; nozzle diameter, 0.20 inch (0.508 cm); gaseous nitrogen.

curve, taken from figure 9, is also shown. The distance between the two curves represents the bow shock standoff distance. The results of the experiments to determine the effect of nozzle-cavity gap on resonance heating indicate that varying the gap does, in fact, seem to vary the bow shock relative to the unstable zones of the jet flow field. As a result, there is a corresponding nozzle-cavity gap that yields the best resonant coupling, as indicated by the peak in the cavity-base temperature curve. The most significant result found was that the nozzle gap effect was controlled solely by the nozzle diameter and the ratio of nozzle pressure to ambient pressure. If the pressure ratio and the nozzle diameter are fixed, so is the nozzle gap corresponding to a peak in the cavity-base temperature.

Effect of nozzle pressure and nozzle pressure/ambient pressure ratio. - The first experiment in this series was to maintain a fixed pressure ratio and vary nozzle pressure. At each nozzle pressure, the peak in temperature and pressure amplitude as a function of nozzle gap was obtained. The variation in peak oscillatory pressure amplitude at the cavity base as a function of nozzle pressure is shown in figure 12. The results indicate a linear variation of amplitude with nozzle pressure, but they also indicate that a pressure ratio of 4.5 is superior to either 6 or 8 at any given nozzle pressure. Thus, for a given configuration and nozzle pressure, it would appear to be most efficient to operate at pressure ratios of about 4.5 (i. e. , higher values of ambient pressure) by proper restriction of the can orifice area.

The relation of pressure amplitude to cavity-base temperature was examined next. Peak cavity-base temperatures were measured as functions of nozzle pressure at fixed pressure ratios. A sample result is shown in figure 13. In this case, we can see a definitely nonlinear variation of temperature with nozzle pressure or, using the results of the previous plot, a nonlinear variation of temperature with wave amplitude, particularly as the nozzle pressure exceeds 50 psia (345 kN/m²).

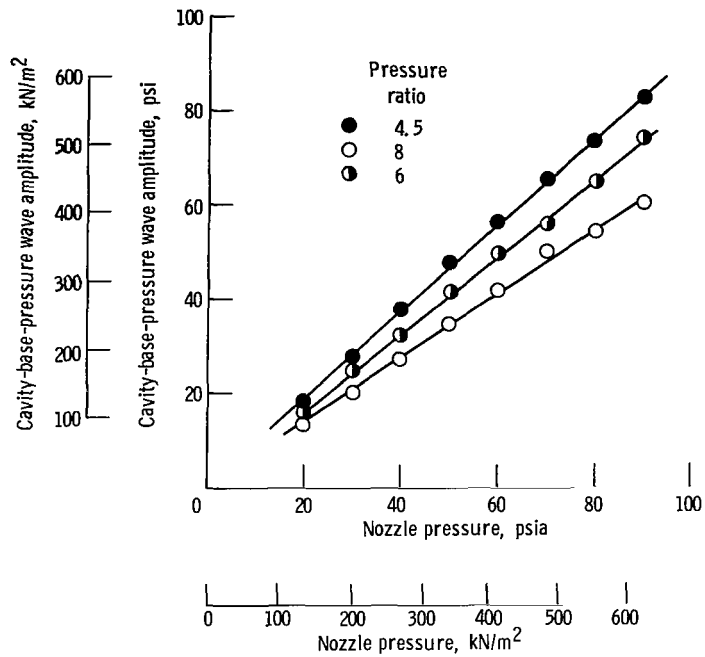

Figure 12. - Cavity-base wave amplitude as function of nozzle pressure for various pressure ratios. Brass resonance tube 0.25 inch (0.635 cm) in diameter and 3.35 inches (8.5 cm) in depth; nozzle-cavity gap, 0.45 inch (1.143 cm); nozzle diameter, 0.20 inch (0.508 cm); gaseous nitrogen.

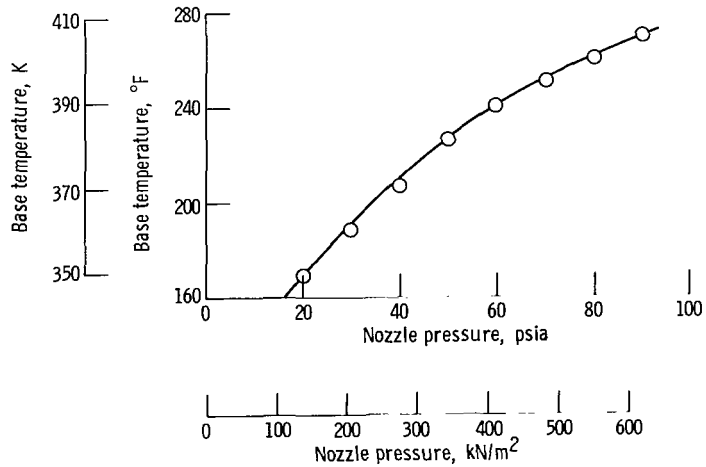

Figure 13. - Effect of nozzle pressure on peak cavity-base temperature. Pressure ratio, 4.5; brass resonance tube 0.25 inch (0.635 cm) in diameter and 3.35 inches (8.5 cm) in depth; nozzle-cavity gap 0.785 inch (2.0 cm); nozzle diameter, 0.20 inch (0.508 cm); gaseous nitrogen.

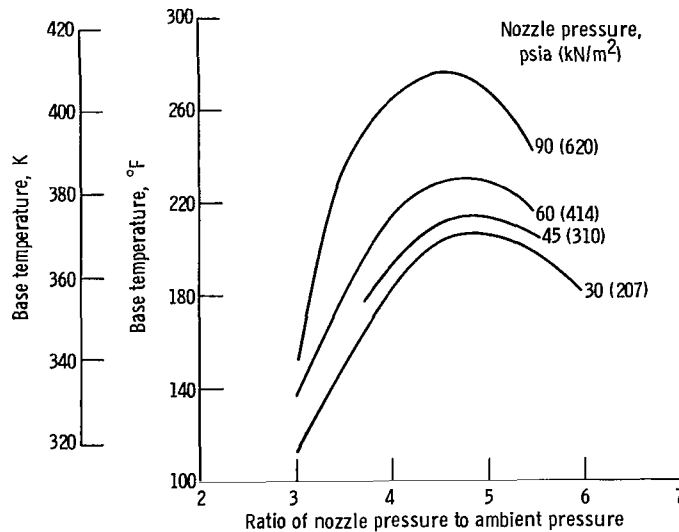

Figure 14. - Effect of ratio of nozzle pressure to ambient pressure on peak cavity-base temperature for various nozzle pressures. Brass resonance tube 0.25 inch (0.635 cm) in diameter with ceramic piston and 3.35 inches (8.5 cm) in depth; nozzle diameter, 0.20 inch (5.08 cm); gaseous nitrogen.

A crossplot of peak cavity-base temperature as a function of pressure ratio at fixed values of nozzle pressure is shown in figure 14. At a nozzle pressure ratio between 4.5 and 4.8, a maximum temperature is achieved for this particular nozzle size (0.20 in., 0.508 cm). Additional testing with other nozzle diameters also gave an optimum nozzle pressure ratio of approximately 4.5.

Both the peak pressure amplitude and the peak temperatures are realized at a pressure ratio of 4.5, but the reasons for this are not known at this time.

Effect of nozzle diameter. - Each nozzle was tested at its optimum position and pressure ratio. The temperature peaks were plotted as a function of nozzle diameter. This result is shown in figure 15. For a cavity diameter of 0.25 inch (0.635 cm), there is a definite peak at a nozzle diameter of about 0.20 inch (0.508 cm). Because there were no nozzles tested at intermediate diameters, it was not clear exactly where the peak was, however, the 0.20-inch (0.508-cm) nozzle was used as an "optimum" diameter.

Effect of nozzle expansion area ratio. - The effects of nozzle expansion area ratio on the resonance tube operation were evaluated at a variety of conditions. The nozzle gap was varied from 0 to 1.00 inch (0 to 2.54 cm), the cavity depth was varied from 0 to 3.64 inches (0 to 9.24 cm), the nozzle pressure was varied from 45 to 90 psia (310 to 620 kN/m²), and the ratio of nozzle pressure to test chamber pressure was varied from 3.5 to 360. Only two nozzle extensions were evaluated. These were the 4:1 and 9.5:1 nozzle area ratio extensions. The results are presented as the maximum cavity-base pressure amplitude as a function of the nozzle area ratio and are shown in figure 16. The maximum

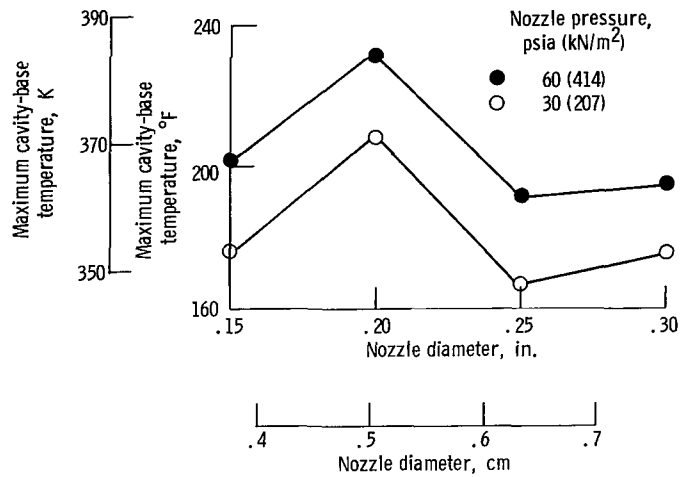

Figure 15. - Effect of nozzle diameter on maximum cavity-base temperature for two nozzle pressures. Brass resonance tube 0.25 inch (0.635 cm) in diameter and 3.35 inches (8.5 cm) in depth; ceramic piston; gaseous nitrogen.

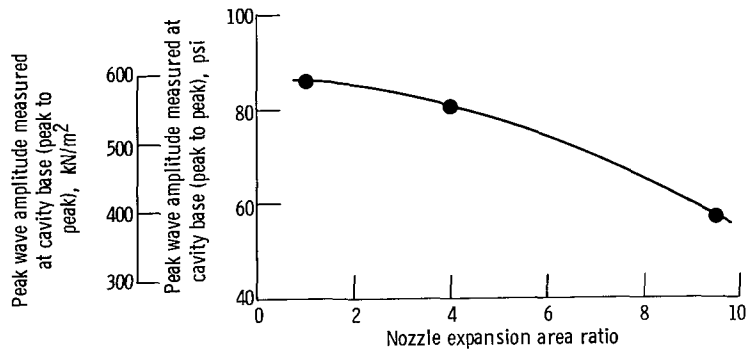

Figure 16. - Effect of nozzle expansion area ratio on peak cavity-base pressure amplitude. Brass resonance tube 0.25 inch (0.635 cm) in diameter; nozzle diameter, 0.20 inch (0.508 cm).

amplitude corresponded to the simple sonic nozzle (area ratio of unity). Based on these results, no further tests with the nozzle extensions were carried out.

Effect of trips. - According to the results presented by Sprenger in reference 2, there was some advantage to be gained by providing a trip of some sort to enhance the maximum temperature to the resonance tubes. A simple bare-steel wire 1/32 inch (0.079 cm) in outside diameter placed diametrically across the tube aperture was used as a trip.

The results of the variation in trip position are presented in figure 17. In general, the results were negative, at least with the 0.20-inch (0.508-cm) nozzle used in the tests. As a result, the use of trips was not pursued further.

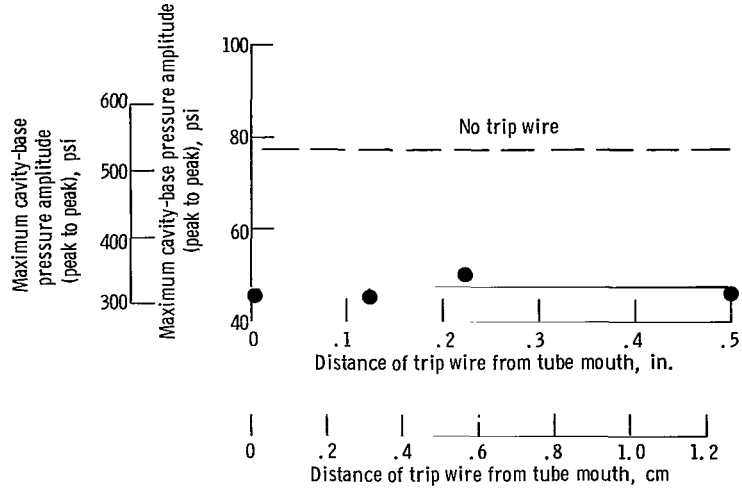

Figure 17. - Effect of trip wire placement on maximum cavity-base pressure amplitude. Brass resonance tube 0.25 inch (0.635 cm) in diameter and 1.00 inch (2.54 cm) in depth; nozzle diameter, 0.20 inch (0.508 cm); nozzle pressure, 90 psia (620 kN/m²); ratio of nozzle pressure to ambient pressure, 6.2; gaseous nitrogen.

Effect of tube materials. - The mechanism by which the shock waves are caused to travel through a quantity of gas trapped within the tube has already been discussed. Some of the variables that control the initiation and amplification of the shock oscillations had been optimized. The next step was to study the effect of tube materials on the maximum temperatures produced at the base of the cavity.

To minimize heat loss from the gas to the resonance tube walls, a tube material with a low thermal conductivity was considered most promising. Some candidate materials and thermal conductivities are presented in table I. In evaluating the materials, it was

TABLE I. - ROOM-TEMPERATURE THERMAL CONDUCTIVITIES OF CANDIDATE RESONANCE CAVITY MATERIALS

Material	Conductivity, J/(m)(sec)(K)
Brass	109
Wood	0.12
Asbestos	
Composite A (Marinite 65 ^a)	0.245
Composite B (Marinite 36)	0.109
Composite C (Marinite 23)	0.082
Pyrolytic graphite (C direction)	1.25
Foamed zirconia	0.42
Asbestos phenolic	0.129
Magnesia	0.189

^aTrademark of John-Manville Corp.

determined that structural strength and impermeability were also important factors. For example, one of the materials tested was a foamed zirconia. This material has a very low conductivity and high strength, yet it was unsuccessful due to the absorption of the compression waves by the porous wall structure. Another example was found while evaluating the various asbestos composites. These composites are differentiated by the percentage of binder used. Lesser amounts of binder resulted in lower density, strength, and thermal conductivity. The material with the lowest percentage of binder was most successful in terms of giving high cavity-base temperatures, yet it failed by cracking after only one or two ignition attempts. Because of machinability and these considerations, asbestos composite A was selected as most suitable.

Effect of cavity depth. - According to the literature, the effect of changing the resonance tube cavity depth is to provide a varying length of travel for the compression or shock waves as they oscillate up and down within the resonance cavity. As the travel length is increased, the compression waves tend to combine, steepen, and form shocks. As the tube length increases, the period of wave oscillation will also uniformly increase, provided the wave propagation velocity remains constant. An example of these results is seen in figure 18, which is a typical result of increased cavity depth on cavity-base pressure amplitude and measured period. The maximum wave amplitude is reached at approx-

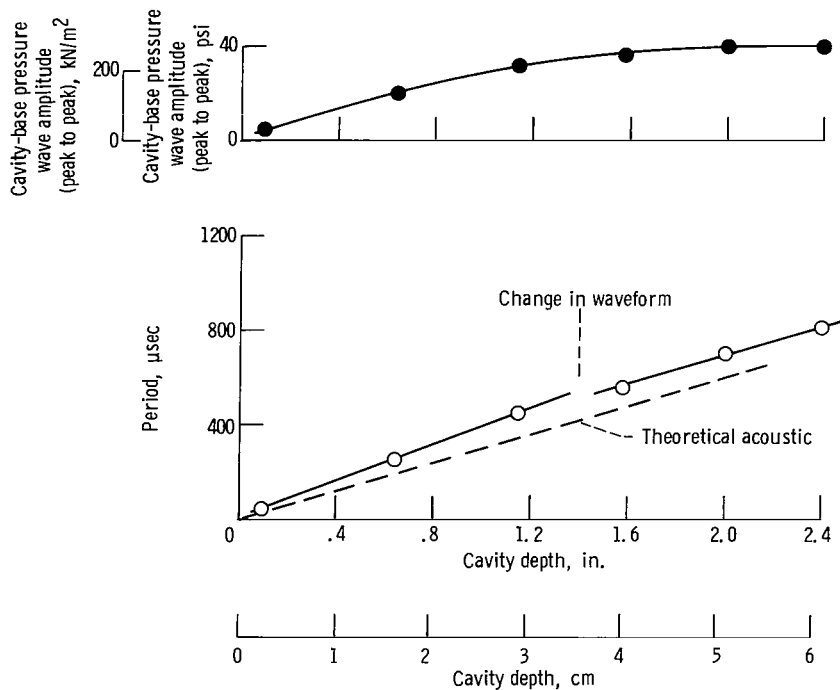

Figure 18. - Effect of cavity depth on cavity-base pressure wave amplitude and wave period. Brass resonance tube 0.25 inch (0.635 cm) in diameter; nozzle pressure, 45 psia (310 kN/m²); nozzle-cavity gap, 0.805 inch (2.09 cm); ratio of nozzle pressure to ambient pressure, 6.0; gaseous nitrogen.

imately 2.0 inches (5.08 cm) of depth. The peak magnitude of the wave amplitude is 40 psi (276 kN/m²) peak-to-peak (which corresponds fairly closely to the nozzle pressure of 45 psia (310 kN/m²)). A similar result is noted at other nozzle pressures. The measured wave period as a function of the cavity depth is also shown in figure 18. For comparison, the "acoustic" value is plotted on the same scale, showing the deviation due to excess shock-path length outside the tube (shock standoff distance).

Transition from a sinusoidal-type wave to a "shock"-type wave occurred at approximately 1.4 inches (3.56 cm) cavity depth. The two wave shapes are presented for comparison in figure 19. The second wave shape is characteristic of high-amplitude pressure oscillations in tubes (ref. 6).



(a) Cavity depth, 0.66 inch (1.67 cm); period, 300 microseconds.



(b) Cavity depth, 3.4 inches (8.64 cm); period, 1120 microseconds.

Figure 19. - Effect of cavity depth on cavity-base pressure wave shape. (Same conditions as fig. 18.)

The evaluation of the effect of cavity depth on maximum temperature involved the variation of nozzle pressure at a pressure ratio of 4.5 and a gap of 0.45 inch (1.143 cm) while measuring the steady-state cavity-base temperature. The results are presented in figure 20. Each of the curves represents a given cavity depth. The results clearly indicate that a short tube is preferred. Referring back to figure 18, it was shown that although the wave amplitude increases, at least up to 2.0 inches (5.08 cm) of depth, the period also increases. Thus, for a change from 2.0 inches to 4.0 inches (5.08 cm to 10.16 cm), the wave amplitude increases negligibly, but the period increases by a factor of 2. Accordingly, for a given energy addition per cycle, the energy addition per unit of time is twice as high with the 2.0-inch (5.08-cm) tube, as with the 4.0-inch (10.16-cm) tube.

Another factor which enters into the problem is that increasing the length of the tube

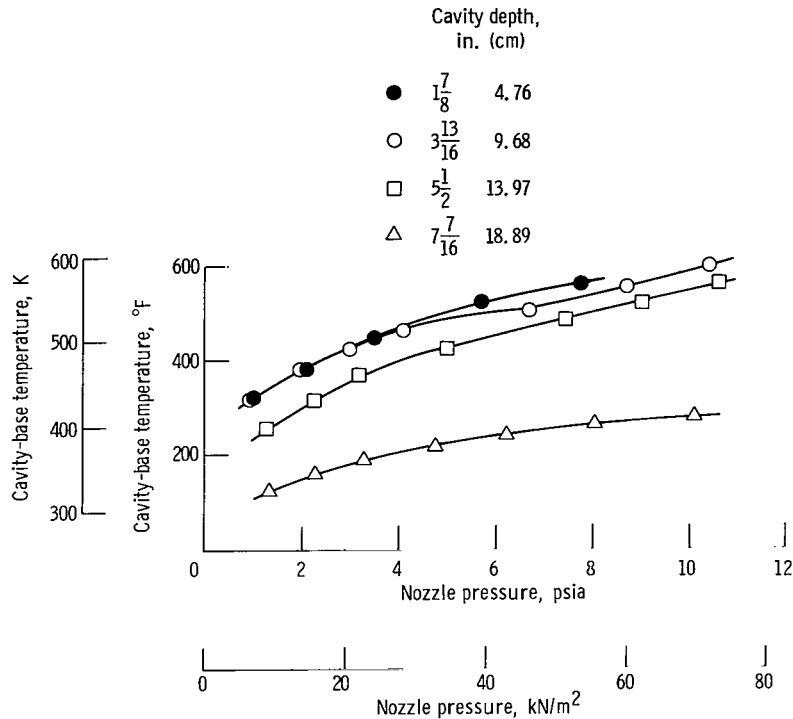

Figure 20. - Effect of nozzle pressure on cavity-base temperature for various cavity depths. Resonance tube constructed of asbestos composite A and 0.25 inch (0.635 cm) in diameter; nozzle diameter, 0.20 inch (0.508 cm); nozzle gap, 0.45 inch (1.143 cm); ratio of nozzle pressure to ambient pressure, 4.5; gaseous hydrogen; tube shape, cylindrical.

increases the surface area for thermal conduction and convection losses. In any case, a cavity depth anywhere between $1\frac{7}{8}$ inches and $3\frac{3}{16}$ inches (4.76 cm and 9.68 cm) appears to be the best for the range of conditions studied.

Effect of tube shape. - According to the results presented in reference 7, by McAlevy and Pavlak, tapering the resonance tube will increase the frequency by 50 percent or, for the same heat input per cycle, increase the heat input per unit of time by 50 percent. The tapered tubes used herein to obtain this increased heating were described in the section APPARATUS. Evaluation and comparison of results obtained with both a cylindrical and a tapered cavity are shown in figure 21. The superiority of tapering is clearly indicated, with the base temperature more than doubled. The trend of the data with the tapered cavity clearly indicates that temperatures well above 1000° F (811 K) are possible at nozzle pressures above 1.0 psi (6.9 kN/m²). However, no runs were made at higher pressures because the thermocouple was calibrated only to 1000° F (811 K) since this is adequate for ignition purposes.

Although it was previously established that there was no advantage in increasing the cavity length from $1\frac{7}{8}$ inches to $3\frac{3}{16}$ inches (4.76 cm to 9.68 cm) for the cylindrical cavity, it was not known what effect an increase in length would have on a tapered cavity. Conse-

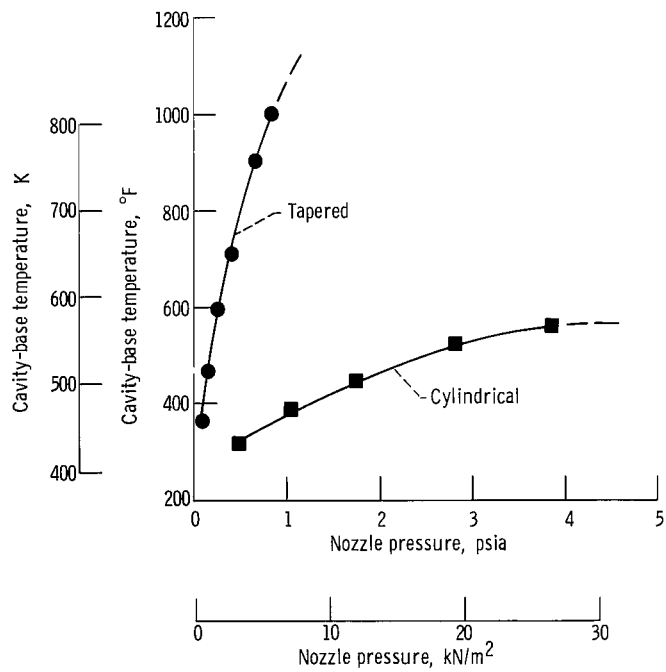

Figure 21. - Effect of tube shape on cavity-base temperature. Resonance tube constructed of asbestos composite A; nozzle diameter, 0.20 inch (0.508 cm); nozzle gap, 0.45 inch (1.143 cm); ratio of nozzle pressure to ambient pressure, 4.5; gaseous hydrogen.

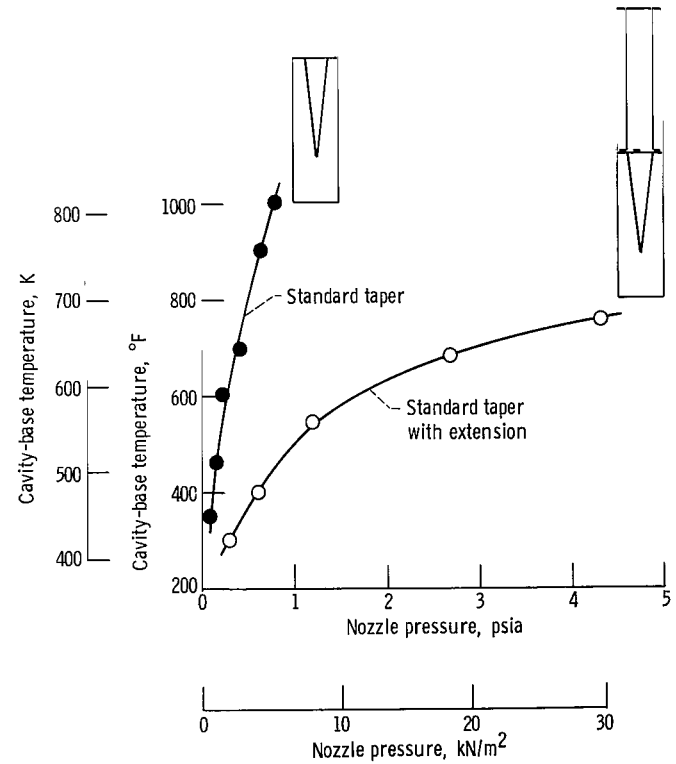

Figure 22. - Effect of a 2.0-inch (5.08-cm) cylindrical extension on a tapered resonance tube. Tube constructed of asbestos composite A; nozzle diameter, 0.20 inch (0.508 cm); nozzle gap, 0.45 inch (1.143 cm); ratio of nozzle pressure to ambient pressure, 4.5; gaseous hydrogen.

quently, the standard tapered tube was tested with and without a 2.0-inch (5.08-cm) cylindrical extension. The results are presented in figure 22, with the standard taper clearly superior. The cause of the change is due to a decrease in the frequency as the length was increased. The standard taper was considered as an acceptable configuration for ignition studies from this point on.

Effect of gas composition. - To study the effects of gas composition on the resonance heating process, the identical configuration was tested with both gaseous hydrogen and gaseous nitrogen. Prior testing had assured that the pressure ratio and nozzle-cavity gap was optimum for both gases. Shown in figure 23 is a plot of cavity-base temperature as a function of nozzle pressure for both pure hydrogen and pure nitrogen. The results are very similar if oxygen is substituted for nitrogen in this experiment. Clearly, the hydrogen produces higher temperatures. Thus for hydrogen-nitrogen or hydrogen-oxygen mixtures, the richer the mixture in hydrogen, the higher the temperature.

As a possible explanation for the effect of gas composition, attention can be drawn to the fact that for the same conditions, the frequency of oscillation of the tube with hydrogen is at least three to four times greater than with nitrogen. This is due to the effect of molecular weight changes on sonic velocity. If the energy input per cycle is equal for the

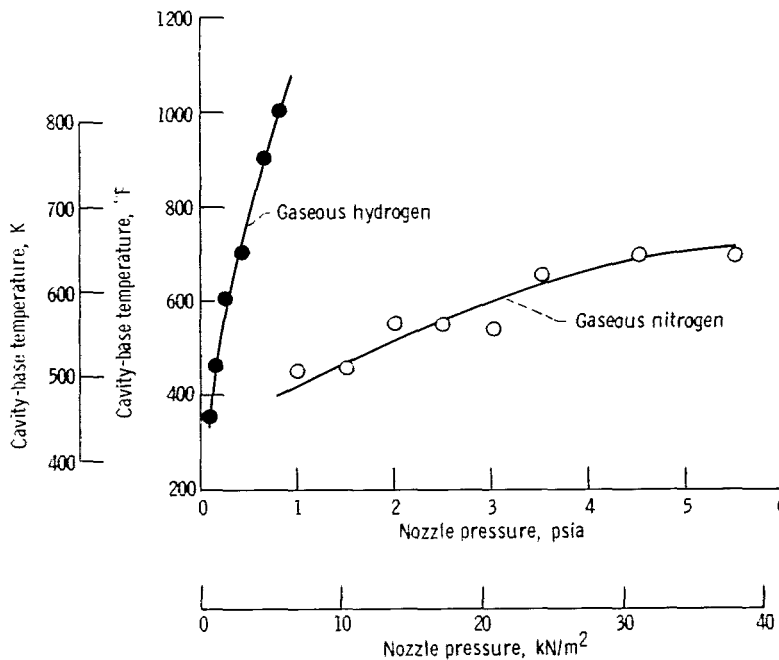

Figure 23. - Effect of gas composition on cavity-base temperature. Tapered resonance tube of asbestos composite A; nozzle diameter, 0.20 inch (0.635 cm); nozzle gap, 0.45 inch (1.143 cm); ratio of nozzle pressure to ambient pressure, 4.5.

two gases, the energy input per unit time is three to four times greater for the H₂ system. This is a similar argument to that used to explain the effect of tapering the resonance tube.

Determining the most suitable igniter configuration. - Based on the results of the experiments previously presented, the following configuration was selected as that most suitable for ignition experiments:

- (1) Nozzle diameter, 0.20 inch (0.508 cm)
- (2) Nozzle-cavity gap, 0.45 inch (1.143 cm)
- (3) Tube shape, 6° conical taper to 0.25-inch (0.635-cm) diameter
- (4) Maximum depth, 1 $\frac{7}{8}$ inch (4.76 cm)
- (5) Tube material, asbestos composite A
- (6) Nozzle ambient pressure ratio, 4.5

Once these values had been decided on, a configuration using them was constructed. This fixed-gap igniter configuration was described in the section APPARATUS (fig. 7(a)), except that a conical cavity was used. All ignition tests were conducted with this configuration.

Parameters That Influence Ignition

Typically, ignition runs involved pressurizing the propellant systems up to the run valves and evacuating the test chamber to 0.07 (0.48 kN/m²) psia. The variable-area orifice valves were adjusted so that the pressures of both propellants at the nozzle entrance were equal for each mixture ratio. The actual flow rates were determined by measuring the upstream pressure and temperature since the orifices were operated choked. The nozzle pressure, the can pressure, the cavity-base temperature, and the can temperature were all recorded on an oscillograph. A sample run is shown in figure 24.

The beginning of the run is indicated by the rise in the nozzle and can pressures. Simultaneously, the cavity-base temperature starts to increase. If the conditions are suitable, at some time after the start of the run, a sharp temperature rise is seen within the can. This temperature rise, together with the jumps in the other traces, indicates that ignition has occurred and has propagated into the can. The ignition lag indicated on the figure corresponds to the time between temperature startup and ignition sensing. Because of the mass of the thermocouple junction, the trace of cavity-base temperature lags the actual temperature somewhat.

Because of the potential for hardware damage with hydrogen-oxygen combustion, even at low pressures and low oxygen-fuel ratios, the ignition runs were automatically terminated when ignition was sensed. Thus, the temperature in both the cavity and the can decreased toward ambient immediately after the run valves were shut off. The particular

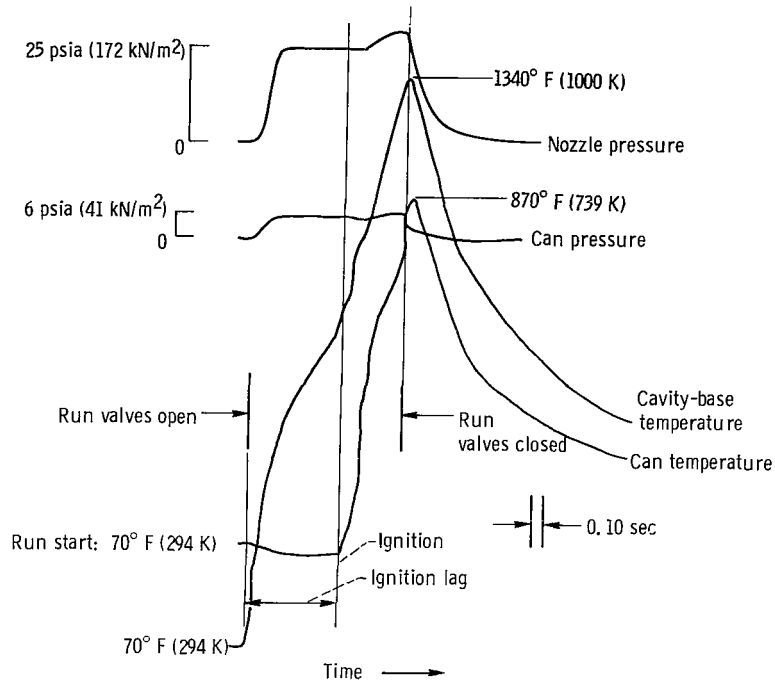

Figure 24. - Oscillograph traces of typical ignition test.

run shown was with an oxygen-fuel ratio near unity and a nozzle pressure of approximately 25 psia (172 kN/m^2).

Effect of nozzle pressure. - The results of evaluation of the ignition lag as a function of the nozzle pressure are shown in figure 25. It was not possible to obtain ignitions at nozzle pressures lower than 6 psia (41 kN/m^2). As the pressure was increased from 6 to 10 psia (41 to 69 kN/m^2), the ignition lag was decreased markedly, but above 10 psia (69 kN/m^2) only slight improvements are shown. The minimum ignition lag recorded in the program was 0.13 second at a pressure of 35 psia (241 kN/m^2). Increasing the pressure to 50 psi (345 kN/m^2) did not change this value. It is noteworthy here that cryogenic propellant tanks must normally be maintained at a minimum pressure of 25 to 35 psia (172 to 241 kN/m^2) to provide adequate net positive suction head for the engine pumps. Thus, the pressures normally available correspond to the range of minimum ignition lag.

Effect of mixture ratio. - To determine the best oxidant-fuel ratios for ignition, two conflicting trends must be reconciled. The first trend is toward an increasing ignition energy requirement as the oxygen-fuel (O/F) ratio is decreased from 30. The energy required increases sharply as an O/F of 1.0 is approached (ref. 1). In addition, the flammability limit of hydrogen-oxygen mixtures is generally taken to be near an O/F of 1.0. In contrast to this trend is the experimental observation that hydrogen-rich mixtures get hotter in the resonance tubes, as may be surmised from figure 23. The net effect of mixture ratio variations is shown in figure 26. These results, although slightly distorted due

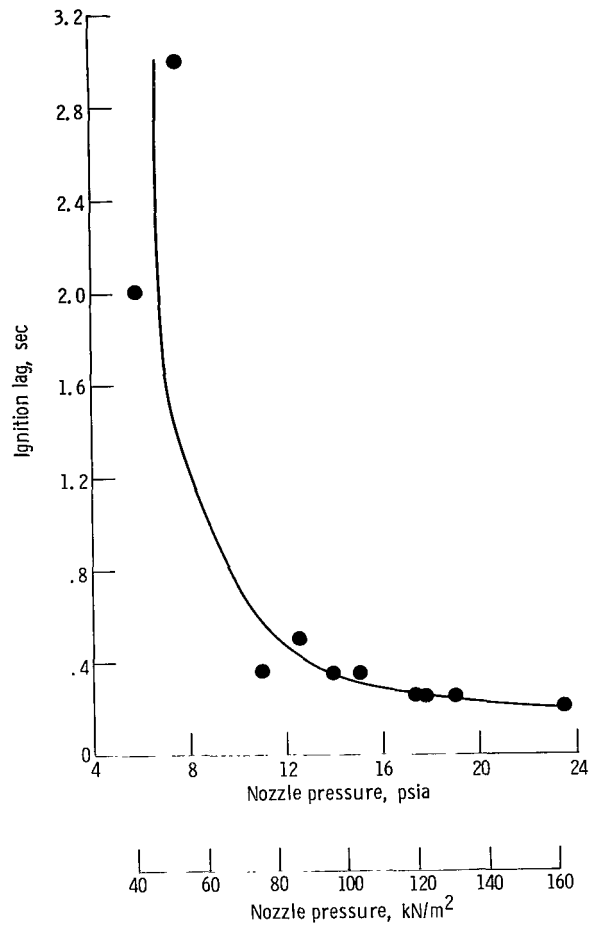

Figure 25. - Ignition lag as function of nozzle pressure. Tapered resonance tube constructed of asbestos composite A; oxygen-hydrogen ratio, 1; nozzle diameter, 0.20 inch (0.508 cm); nozzle gap, 0.45 inch (1.143 cm); ratio of nozzle pressure to ambient pressure, 4.5.

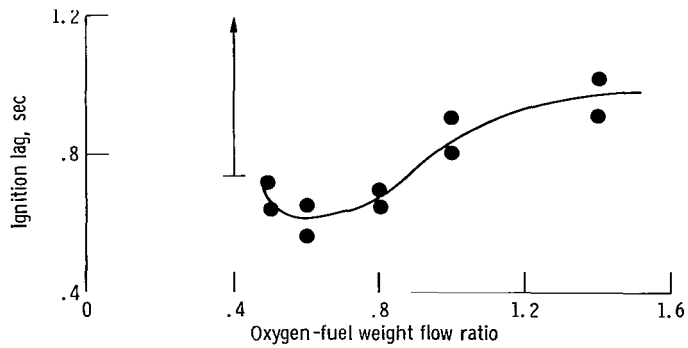

Figure 26. - Effect of oxygen-hydrogen ratio on ignition lag. Tapered resonance tube constructed of asbestos composite A; nozzle diameter, 0.20 inch (0.508 cm); nozzle gap, 0.45 inch (1.143 cm); nozzle pressure, 12 psia (82.7 kN/m²); ratio of nozzle pressure to ambient pressure, 4.5.

to an imperfect thermocouple seal, indicate that the minimum ignition lag occurs at an oxygen-hydrogen mixture ratio near 0.6. Reducing the O/F to less than 0.5 led to variable ignition lags, perhaps due to the inability to mix well in the nozzle.

The increase in cavity-base temperature as the weight fraction of hydrogen was increased suggested alternate methods to improve the ignition performance. The methods tried involved introducing only the hydrogen first to obtain rapid increases in the temperature. At some later time, the oxygen was introduced, either into the nozzle or directly into the base of the cavity through the thermocouple port. In the first instance, the introduction of oxygen into the nozzle was followed by an appreciable lag until the system reached a new steady state, at which time ignition occurred. The overall time, however, from hydrogen run valve opening until ignition was not decreased, and was, in some instances, increased.

Introducing the oxygen through the thermocouple port resulted either in the time ignition lag as for simultaneous run valve openings, or in ignition and burning within the resonance tube with no propagation into the can until some time much later. In both approaches, the results were not encouraging enough to suggest further efforts.

At this point in the experimental program, it should be noted that a configuration was available that could provide rapid and consistent ignitions of hydrogen-oxygen mixtures. It operated at O/F ratios between 0.6 and 1.0 and at ambient temperatures. It was possible to record over 50 separate ignitions with a single igniter. In no case was there ever a failure to ignite at ambient gas supply temperatures.

Effect of propellant inlet temperature. - Because the igniter was envisioned as part of a reusable engine system for space vehicles, one requirement was the ability to ignite gases which had been stored in space for extended periods. For an hydrogen-oxygen rocket engine, the lower bound on the gas temperature available could conceivably be as low as the liquid-oxygen tank temperature. This is of the order of -300° F (89 K). Because of the extremely small igniter flow rates (0.001 lb/sec, 0.4536 g/sec), the upper bound on the gas temperature will depend on the temperature of the engine piping system and engine hardware.

To satisfy the requirement that the igniter be usable at those low temperatures, it was necessary to evaluate the effects of propellant inlet temperature on the ignition process. By proper adjustment of the liquid level in the propellant conditioning baths, it was possible to cool the propellants to -265° F (108 K). The propellant temperature quoted is that measured within the nozzle.

Initial experimentation involved determining the effect of varying nozzle inlet temperature on the cavity-base temperature. The results are shown in figure 27. A nozzle pressure of 1 psia (6.9 kN/m^2) was chosen to keep the maximum temperature within the calibrated range of the thermocouple. The cavity temperature decreases linearly as a function of the nozzle temperature, with a slope of 2° of cavity temperature for each de-

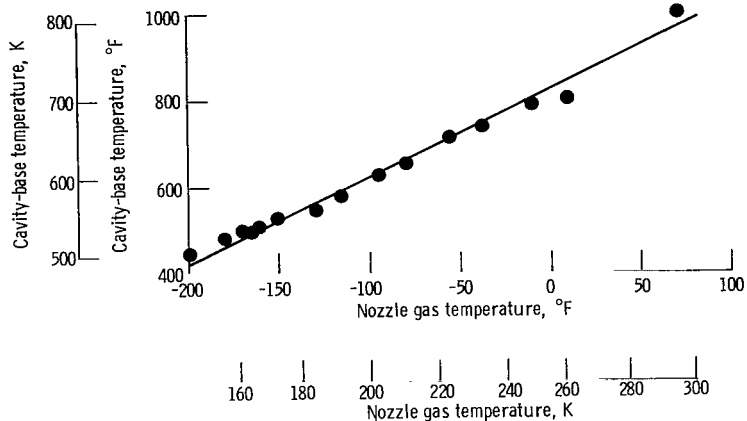

Figure 27. - Effect of nozzle gas temperature on cavity-base temperature. Tapered resonance tube constructed of asbestos composite A; nozzle diameter, 0.20 inch (0.508 cm); nozzle gap, 0.45 inch (1.143 cm); nozzle pressure, 1 psia (6.9 kN/m²); ratio of nozzle pressure to ambient pressure, 4.5; gaseous hydrogen; ratio of cavity-base temperature change to nozzle temperature change, 2.

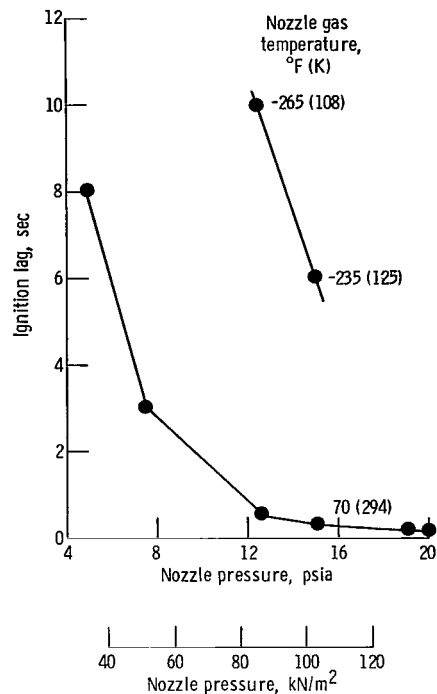

Figure 28. - Effect of nozzle pressure on ignition lag for ambient and cryogenic nozzle gas temperatures. Tapered resonance tube constructed of asbestos composite B; nozzle diameter, 0.20 inch (0.508 cm); nozzle gap, 0.45 inch (1.143 cm); ratio of nozzle pressure to ambient pressure, 4.5; oxygen-hydrogen ratio, 0.8.

gree of nozzle temperature. This strong sensitivity raises doubts as to whether the igniter is suitable for operating at liquid-nitrogen temperatures.

The next stage in the evaluation of the effects of propellant temperature was to try to ignite hydrogen-oxygen mixtures that had been chilled to cryogenic temperatures. There was some difficulty in this phase of the experimentation due to the tendency for a portion of the oxygen to condense, particularly as the line or supply pressure was increased. Only two ignitions were obtained with hydrogen-oxygen mixtures which had been cooled to near -250° F (117 K) and these results are presented in figure 28. For comparison, the curve of ignition lag against nozzle pressure for ambient temperature propellants is shown in the same figure. The minimum time for ignition to be sensed was 6 seconds. In certain instances, it was found that, although the gases in the base of the resonant tube had ignited and were burning, it was not possible to sense ignition within the can. This condition was noted as the nozzle supply pressure was increased to reduce the ignition lag. In addition, because of oxygen condensing due to exposure either to cold lines or to the cold hydrogen, the mixture ratio was impossible to define in many instances. Another critical parameter was the degree of temperature conditioning of the igniter material. Because

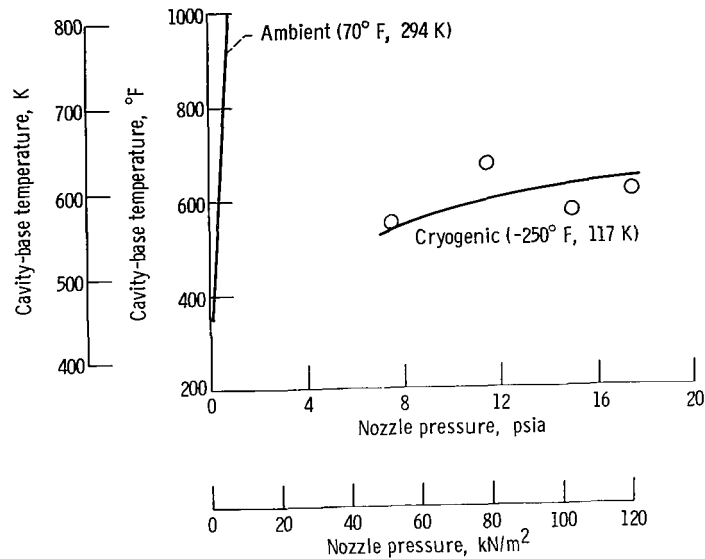

Figure 29. - Effect of nozzle pressure on cavity-base temperature for ambient and cryogenic nozzle gas temperatures. Tapered resonance tube of asbestos composite A; nozzle diameter, 0.20 inch (0.508 cm); nozzle gap, 0.45 inch (1.143 cm); ratio of nozzle pressure to ambient pressure, 4.5.

the cavity was constructed of asbestos, its internal temperature was strongly dependent on how long it had been precooled with liquid nitrogen prior to an ignition attempt.

To understand better what the basic limitations were on the ignition process, an effort was made to measure the effect of nozzle pressure on steady-state cavity temperature for hydrogen cooled to -250°F (117 K). The results of this effort are seen in figure 29 and serve to explain why it was not possible to decrease the ignition lag by increasing the nozzle pressure, even when precautions were taken to prevent oxygen condensation. The results show a peak level in the cavity-base temperature which is much below what is required for ignition. Based on the result of this experiment, it might be concluded that the previously recorded ignitions were made possible only because the asbestos tube materials had not been sufficiently chilled. The inability of increased nozzle pressure to increase cavity-base temperature is difficult to explain. But an initial attempt was made when it was realized that decreasing the temperature of hydrogen tended to increase specific-heat ratio γ from 1.4 to 1.6. While this is not significant in itself, what is significant is the fact that a change in γ changes the position of the cell in an underexpanded jet. After varying the nozzle-cavity gap at constant values of the pressure ratio, it was determined that this detuning due to a change in γ was not the cause, since there was no increase in temperature at other nozzle gaps. What must be surmised is that the existing loss mechanisms, while not sufficient to cause difficulty at ambient temperatures, are sufficiently enhanced at low temperatures so that increasing the nozzle pressure increases the losses

more than it increases the gains. Thus, it was not possible to increase the cavity-base temperature by increasing the supply pressure.

The most serious deficiency of the resonance tube is the inability to achieve adequate temperature for ignition when the gas is at liquid-hydrogen temperatures, even with pure hydrogen. If it is assumed that the present configuration is optimal, then it will obviously not be possible to ignite hydrogen-oxygen mixtures at this low temperature. However, the requirement to ignite at this low temperature might be too severe, since in an actual engine configuration, the first propellants to the engine will be considerably warmer. Typical hydrogen temperatures to the RL-10 engine igniter during starts in space range from -70° to -150° F (217 to 172 K). This is considerably warmer than the coldest propellants ignited in this program (-265° F, 108 K).

SUMMARY OF RESULTS

In an investigation intended to lay the groundwork for the design and demonstration of a practical engine igniter, the following significant progress has been shown.

1. Rapid and reliable ignitions (over 50 ignitions with no failures) were demonstrated with ambient-temperature propellant supplied to the nozzle.

2. At 70° F (294 K), a minimum ignition delay of 0.13 second was observed as nozzle pressure was increased to 35 psia (241 kN/m^2). Further increases in pressure did not measurably decrease the delay.

3. The variation in resonance heating as a function of nozzle-cavity gap could be approximately predicted by a knowledge of the nozzle pressure/ambient pressure ratio and the nozzle diameter.

4. The optimum value of nozzle pressure/ambient pressure ratio was 4.5, which was maintained by enclosing the nozzle-cavity gap with a chamber having properly sized outlet orifices.

5. The optimum nozzle diameter for the 0.25-inch (0.635-cm) diameter resonant tube was 0.20 inch (0.508 cm). Increasing the nozzle expansion area ratio or providing a trip at the entrance to the cavity did not enhance the resonance heating process.

6. The resonance tube that gave the highest cavity-base temperatures was $1\frac{7}{8}$ -inch (4.76-cm) deep with a 6° included angle taper and was fabricated from a commercially available asbestos composite.

7. The optimum oxygen-fuel weight ratio for ignition was between 0.6 and 1.0.

8. Ignition was not obtained when the gases were cooled to near liquid-hydrogen temperatures. The temperature of the coldest gas that was ignited was -265° F (108 K).

Lewis Research Center,
National Aeronautics and Space Administration,
Cleveland, Ohio, February 9, 1971,
731-12.

REFERENCES

1. Lewis, Bernard; and vonElbe, Guenther: Combustion, Flames, and Explosions of Gases. Second ed., Academic Press, Inc., 1961.
2. Sprenger, H.: On Thermal Effects in Resonance Tubes. Mitt. Eidgenoss. Tech. Hoch. Inst. Aerodynamik, Zuerich, no. 21, 1954, pp. 18-35.
3. Conrad, E. William; and Pavli, Albert J.: A Resonance-Tube Igniter for Hydrogen-Oxygen Rocket Engines. NASA TM X-1460, 1967.
4. Hartmann, J.: Production by Means of an Air-Jet of Acoustic Waves of Velocity Exceeding that of Sound. Phil. Mag., vol. 11, Apr. 1931, pp. 926-948.
5. Thompson, Philip A.: Resonance Tubes. Ph.D. Thesis, Dept. of Mech. Eng., Mass. Inst. Tech, 1960.
6. Kang, Sang-Wook: Resonance Tubes. Ph.D. Thesis, Dept. of Mech. Eng., Rensselaer Polytechnic Inst., 1964.
7. McAlevy, Robert F., III; and Pavlak, Alex: Tapered Resonance Tubes: Some Experiments. AIAA J., vol. 8, no. 3, Mar. 1970, pp. 571-572.

FIRST CLASS MAIL



POSTAGE AND FEES PAID
NATIONAL AERONAUTICS AND
SPACE ADMINISTRATION

04U 001 37 51 3DS 71.10 00903
AIR FORCE WEAPONS LABORATORY /WL0L/
KIRTLAND AFB, NEW MEXICO 87117

ATT E. LOU BOWMAN, CHIEF, TECH. LIBRARY

POSTMASTER: If Undeliverable (Section 158
Postal Manual) Do Not Return

"The aeronautical and space activities of the United States shall be conducted so as to contribute . . . to the expansion of human knowledge of phenomena in the atmosphere and space. The Administration shall provide for the widest practicable and appropriate dissemination of information concerning its activities and the results thereof."

— NATIONAL AERONAUTICS AND SPACE ACT OF 1958

NASA SCIENTIFIC AND TECHNICAL PUBLICATIONS

TECHNICAL REPORTS: Scientific and technical information considered important, complete, and a lasting contribution to existing knowledge.

TECHNICAL NOTES: Information less broad in scope but nevertheless of importance as a contribution to existing knowledge.

TECHNICAL MEMORANDUMS: Information receiving limited distribution because of preliminary data, security classification, or other reasons.

CONTRACTOR REPORTS: Scientific and technical information generated under a NASA contract or grant and considered an important contribution to existing knowledge.

TECHNICAL TRANSLATIONS: Information published in a foreign language considered to merit NASA distribution in English.

SPECIAL PUBLICATIONS: Information derived from or of value to NASA activities. Publications include conference proceedings, monographs, data compilations, handbooks, sourcebooks, and special bibliographies.

TECHNOLOGY UTILIZATION PUBLICATIONS: Information on technology used by NASA that may be of particular interest in commercial and other non-aerospace applications. Publications include Tech Briefs, Technology Utilization Reports and Technology Surveys.

Details on the availability of these publications may be obtained from:

SCIENTIFIC AND TECHNICAL INFORMATION OFFICE

NATIONAL AERONAUTICS AND SPACE ADMINISTRATION

Washington, D.C. 20546