



8-1981

Response Latency: A Function of Within-Session Differences in Intertrial Interval, Training History, Cue Condition, and Ratio Requirement

James Bryant Nuzzo

Follow this and additional works at: https://scholarworks.wmich.edu/masters_theses



Part of the Experimental Analysis of Behavior Commons

Recommended Citation

Nuzzo, James Bryant, "Response Latency: A Function of Within-Session Differences in Intertrial Interval, Training History, Cue Condition, and Ratio Requirement" (1981). *Master's Theses*. 1813.

https://scholarworks.wmich.edu/masters_theses/1813

This Masters Thesis-Open Access is brought to you for free and open access by the Graduate College at ScholarWorks at WMU. It has been accepted for inclusion in Master's Theses by an authorized administrator of ScholarWorks at WMU. For more information, please contact wmu-scholarworks@wmich.edu.



RESPONSE LATENCY: A FUNCTION OF WITHIN-SESSION
DIFFERENCES IN INTERTRIAL INTERVAL, TRAINING HISTORY,
CUE CONDITION, AND RATIO REQUIREMENT

by

James Bryant Nuzzo

A Thesis
Submitted to the
Faculty of The Graduate College
in partial fulfillment of the
requirements for the
Degree of Master of Arts
Department of Psychology

Western Michigan University
Kalamazoo, Michigan
August 1981

RESPONSE LATENCY: A FUNCTION OF WITHIN-SESSION
DIFFERENCES IN INTERTRIAL INTERVAL, TRAINING HISTORY,
CUE CONDITION, AND RATIO REQUIREMENT

James Bryant Nuzzo, M.A.

Western Michigan University, 1981

Skinner has suggested that latency does not vary in an orderly manner and short latencies result from the development of effective waiting behavior not specified by the experimental contingencies. Recent experimentation has found latency to vary as a function of a within-session difference in parameters of reinforcement correlated with two components of a discrete-trial multiple schedule. Also found was the attenuation of within-session differences in latencies with the change in intertrial interval (ITI) from 5 seconds to 20 seconds. This suggests that the ITI may be a variable which controls latency. This study investigated the effect on latency of within-session differences in ITI, ITI training histories, ITI cue conditions, and manipulations in the ratio requirement. The results suggest that latency may vary as a function of superstitious ITI response patterns which determine the subject's position at the moment of stimulus onset. Superstitious response patterns varied as a function of changes in the independent variables. A reaction time procedure is recommended to avoid the effects of superstitious behavior on latency.

ACKNOWLEDGEMENTS

I would like to acknowledge the guidance, instruction, and opportunity afforded me by Dr. Jack Michael, who has extensively altered my repertoire. Thanks go to Dr. M. Kay Malott for providing laboratory space and critical review of this research effort, as well as to Dr. R. Wayne Fuqua for his efforts in shaping my research skills. I wish to express a special note of thanks to Paul Whitley for sharing many hours of conversation and speculative analysis during the course of this study. This work is dedicated to Dr. Matthew Israel who is responsible for my interest in behavior analysis, and to my wife, Mary, who has enabled me to pursue this interest.

James Bryant Nuzzo

INFORMATION TO USERS

This was produced from a copy of a document sent to us for microfilming. While the most advanced technological means to photograph and reproduce this document have been used, the quality is heavily dependent upon the quality of the material submitted.

The following explanation of techniques is provided to help you understand markings or notations which may appear on this reproduction.

1. The sign or "target" for pages apparently lacking from the document photographed is "Missing Page(s)". If it was possible to obtain the missing page(s) or section, they are spliced into the film along with adjacent pages. This may have necessitated cutting through an image and duplicating adjacent pages to assure you of complete continuity.
2. When an image on the film is obliterated with a round black mark it is an indication that the film inspector noticed either blurred copy because of movement during exposure, or duplicate copy. Unless we meant to delete copyrighted materials that should not have been filmed, you will find a good image of the page in the adjacent frame. If copyrighted materials were deleted you will find a target note listing the pages in the adjacent frame.
3. When a map, drawing or chart, etc., is part of the material being photographed the photographer has followed a definite method in "sectioning" the material. It is customary to begin filming at the upper left hand corner of a large sheet and to continue from left to right in equal sections with small overlaps. If necessary, sectioning is continued again—beginning below the first row and continuing on until complete.
4. For any illustrations that cannot be reproduced satisfactorily by xerography, photographic prints can be purchased at additional cost and tipped into your xerographic copy. Requests can be made to our Dissertations Customer Services Department.
5. Some pages in any document may have indistinct print. In all cases we have filmed the best available copy.

University
Microfilms
International

300 N. ZEEB RD., ANN ARBOR, MI 48106

1317648

NUZZO, JAMES BRYANT
RESPONSE LATENCY: A FUNCTION OF
WITHIN-SESSION DIFFERENCES IN INTERTRIAL
INTERVAL, TRAINING HISTORY, CUE CONDITION,
AND RATIO REQUIREMENT.

WESTERN MICHIGAN UNIVERSITY, M.A., 1981

University
Microfilms
International

300 N. ZEEB RD., ANN ARBOR, MI 48106

TABLE OF CONTENTS

ACKNOWLEDGEMENTS	ii
LIST OF FIGURES	iv
LIST OF TABLES	v
Chapter	
I. INTRODUCTION	1
II. METHOD	5
Subjects	5
Apparatus	5
Procedure	6
III. RESULTS	18
IV. DISCUSSION	45
REFERENCE NOTES	55
BIBLIOGRAPHY	56

LIST OF FIGURES

1 Basic procedure described in State Notation form 9

2 Median session latencies for Subject 1145 with a cued
5 sec ITI training history 20

3 Median session latencies for Subject 6066 with a cued
5 sec ITI training history 22

4 Median session latencies for Subject 2469 with an uncued
5 sec ITI training history 24

5 Median session latencies for Subject 3115 with a cued
20 sec ITI training history 27

6 Median session latencies for Subject 5172 with a cued
20 sec ITI training history 29

7 Median session latencies for Subject 2054 with an uncued
20 sec ITI training history 31

8 Median session latencies for Subject 5118 with a cued
5 and 20 sec ITI training history 34

9 Median session latencies for Subject 599 with a cued
5 and 20 sec ITI training history 36

10 Median session latencies for Subject 2055 with an uncued
5 and 20 sec ITI training history 38

11 Sample within-session event recordings for five subjects
under three different experimental conditions 41

LIST OF TABLES

1	Initial ITI Duration and Cue Condition for Each Subject	12
2	All Condition Changes by Session for Each Subject	14
3	Session Means and Sample Means for Event-Recorded Sessions ..	42

INTRODUCTION

Latency (the time from stimulus onset to the occurrence of the first response) has infrequently been employed as a dependent variable in the experimental analysis of behavior (Stebbins, 1961). Instead, response rate has served as the primary dependent variable in operant research.

A variety of practical, theoretical, and empirical difficulties has been cited (Skinner, 1961; Stebbins, 1961; Michael, Note 1) as explanations of the infrequent use of latency as a dependent variable.

Skinner (1961) in a review of dependent variables cites empirical findings (1946) which suggest that response latency "does not vary continuously or in an orderly fashion" (1961, p. 44). In addition, Skinner (1961) speculates that latency is partly a function of "effective waiting behavior" or behavior which "marked time" (p. 47), both of which are not explicitly related to the experimental contingencies.

Moody, Stebbins, and Islauer (1971) note the similar problem of specifying the subject's position in the chamber at the moment of stimulus presentation. Second, they suggest that the subject's failure to respond, resulting in no data, is likely with the presentation of a negative stimulus (stimulus negatively correlated with reinforcement or S-). An additional difficulty is that latency varies as a function of stimulus intensity which may further confound the

experimental results of a procedure utilizing more than one antecedent stimulus.

Michael (Note 1) suggests that the unavailability of highly accurate and easily programmed control and data acquisition devices may have contributed to disinterest in latency as a dependent variable.

Despite Skinner's criticisms, latency has been successfully employed in a variety of operant procedures. Schuster (1959) found behavioral contrast with a two-component Multiple Fixed-Ratio, Fixed-Ratio schedule (Multiple FR, FR) employing latency as the dependent variable. That is, with the increase in the ratio required for reinforcement in one component of the multiple schedule, the latency in the unchanged component shortened. Stebbins (1962) found latency in a reaction time procedure varied systematically as a function of between-session manipulations in the amount of reinforcement. In the reaction time procedure the subject depresses and holds the manipulandum in the presence of S1 for a given duration or "foreperiod" and releases the manipulandum with the onset of S2; the latency or "reaction time" is measured from S2 onset to the release of the manipulandum. Latency has been profitably employed in studies of stimulus control (Cross & Lane, 1962; Heinz & Eckerman, 1974; Moody et al., 1971; Stebbins & Lanson, 1961; Stebbins & Reynolds, 1964; Terrace, 1963), schedules of reinforcement (Stebbins, Mead, & Martin, 1959; Stebbins, 1962; Stebbins & Lanson, 1962), and animal

psychophysics (Blough, 1959; Green, Terman, M., & Terman, J., 1979; Saslow, 1968; Stebbins & Miller, 1964; Stebbins, 1970; Terman, M., & Terman, J., 1973).

Local interest in response latency has resulted from the development of a student laboratory project at Western Michigan University. This undergraduate experimental laboratory program, concerned with latency, has generated a thematic line of research by graduate students and faculty. The study which follows is a portion of this thematic line of research effort.

The student laboratory's general procedure involves a discrete-trial two-component multiple schedule, where the components differ in various parameters of reinforcement (ratio required to produce reinforcement, probability of reinforcement, and duration of reinforcement). Random component presentations, constituting trials, are separated by 5 sec intertrial intervals (ITI's). Latency was found to vary systematically as a function of the parameters of reinforcement correlated with each component (Michael, Note 1). Latencies to the stimulus correlated with the better parameters of reinforcement (e.g., fewer responses required, greater probability of reinforcement, longer duration of reinforcement) were shorter than those to the stimulus correlated with the poorer parameters of reinforcement (e.g., more responses required, lesser probability of reinforcement, shorter duration of reinforcement). Michael (Note 2) found during parametric manipulations of various aspects of the general procedure the change

in the ITI from 5 sec to 20 sec attenuated the separation in response latencies correlated with each component (longer latencies became much shorter while shorter latencies increased slightly). With the return to the 5 sec ITI the separation in latencies was recovered.

This attenuation of differential responding as a function of an increase in ITI suggests that ITI duration may be a variable controlling absolute and/or relative response latency. Similarly, Holt and Shafer (1973) found that increasing ITI duration increased matching-to-sample accuracy in the pigeon in an orderly fashion. Holt and Shafer suggest the increased matching-to-sample accuracy is a function of increased attending or observing of the response key afforded by the longer ITI's.

The intent of this study was to determine whether response latency would vary as a function of the duration of the preceding ITI on a within-session basis. In addition, the effect of ITI training history was of interest since in the previous study the subjects which demonstrated the attenuation of the separation in response latencies had exclusive 5 sec ITI histories. Also for some subjects ITI's were cued to increase the likelihood that the different ITI's would develop differential control of response latencies.

METHOD

Subjects

Nine 5-to-8-year-old female White Carneaux pigeons served as subjects. All were experimentally naive at the beginning of the study. They were maintained at approximately 80% of their free-feeding weight. Access to grain served as the reinforcement in the experimental sessions with additional grain rations, necessary to maintain their 80% weight, provided in the home cage. Water and grit were continuously available in the subjects' home cages. One subject, pigeon 2055, died during the course of the experiment.

Apparatus

Three Lehigh Valley Electronics standard three-key pigeon test chambers were utilized. For this experiment only the response key (response key) was employed. The key consisted of a 2.5 cm translucent disk centered 26 cm from the chamber floor and 17.5 cm from either side of the intelligence panel as measured to the center of the response key. A force of $0.2 \text{ N} \pm 0.02 \text{ N}$ was required to operate the key's microswitch. Stimuli transilluminated the response key by an inline, digital readout projector (Industrial Electronics Engineers, Inc., Model #10-3043). Stimuli included: Green, Red, and Yellow (Kodak wratten filters; #74, #72B, and #73, respectively) as well as

a white cross on a black background composed of superimposed vertical and horizontal 2 mm wide lines.

Access to mixed grain occurred with the illumination of the 6 cm X 5 cm hopper opening centered 13.5 cm below the response key. Experimental chamber illumination was provided by a 7.5 watt shielded lamp located 7 cm above the response key. Externally mounted exhaust fans provided ventilation and a continuous masking noise for each chamber. A centrally located 16 X 19 cm one-way mirror in each chamber door permitted direct observation of the chamber's interior.

Direct observation data were collected using three telegraph keys wired to a 20-pen Operation Recorder (Esterline Angus Inc.) which operated at 14 cm per minute. The remaining experimental control and data acquisition procedures were provided by a PDP-8/F minicomputer and RX01 floppy disk-drives (Digital Control Corporation) which were located in a separate room. An interface (State Systems Inc.) connected the experimental chambers with the computer. Experimental control and data acquisition were programmed in SUPERSKED software (Snapper & Inglis, 1980).

Procedure

Shaping

The nine subjects were initially trained to eat grain from the illuminated hopper during its presentation. The grain magazine was

presented at random intervals by means of a hand-activated switch. Hopper training was completed within 3-5 sessions.

Upon completion of hopper training, response key pecks were shaped by reinforcing successive approximations of responding toward the key. The key was yellow during this phase. The first peck closing the response key's microswitch resulted in grain presentation for 4 sec and the initiation of the computer controlled, key training program. The key training program presented 4 sec of reinforcement following each peck on the yellow response key (continuous reinforcement or CRF); the session terminated after the delivery of 50 reinforcements. All pigeons received 3-5 sessions of such training until session durations were under 7 minutes. Subsequently the nine subjects began the basic experimental procedure with each subject assigned to different training conditions specified below.

Basic Procedure

The discrete-trial, two-component, multiple or mixed schedule is diagramed (Figure 1) in terms of State Notation (SUPERSKED, 1980). Components consisted of 5 sec or 20 sec ITI's preceding a single discriminative stimulus. The session began with the illumination of the chamber houselight. The computer program randomly selected a number ("5" or "20"), without replacement, from a specified list and evaluated the selected value in a decision function. If the selected number equalled "5" then the ITI preceding onset of the S^D would be

Figure 1. Basic procedure described in State Notation form.

(Circles represent "states" or environmental conditions. Events occurring before a colon (:) are either the passage of time or behavior. Events which follow a colon are the effects of the preceding event resulting in the transition to the next state. Diamonds indicate "decision" where the occurrence of one of two possible events is conditional upon the results of preceding events.)

LIST B = 5, 5, 5, 20, 20, 20

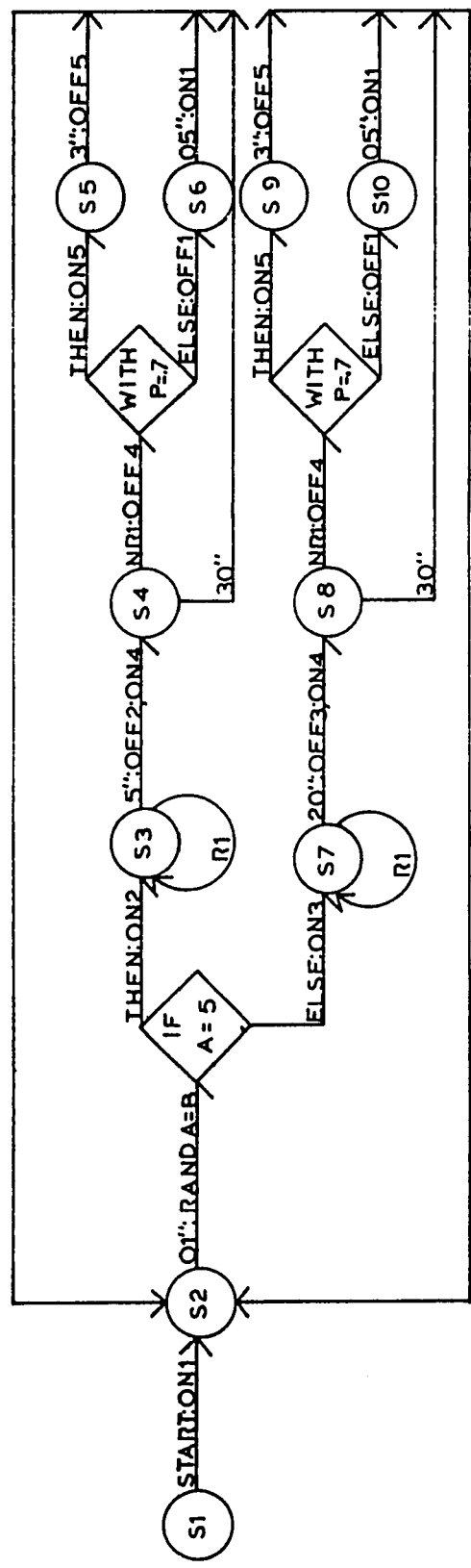

ON1 = HOUSE LIGHT
 ON2 = 5" ITICUE
 ON3 = 20" ITICUE
 ON4 = YELLOW Sd
 ON5 = GRAIN HOPPER

R1 = RESP. TO KEY
 N = NUMBER OF RESP
 P = PROBABILITY

5 sec, but if the selected number did not equal "5" then the ITI would be 20 sec. With the decision a stimulus "cue" (Red, Green, Cross, or dark key) correlated with a specific ITI duration transilluminated the response key and the ITI timer began. Responses to the key during the ITI reset the ITI timer and began the ITI anew. Completion of the ITI terminated the cue and transilluminated the response key with the yellow discriminative stimulus (S^D). As in previous latency studies (Michael, Note 1, Note 2) completion of a specified number of responses (ratio requirement) or the passage of 30 sec (abort limit) terminated the S^D . If the ratio requirement was completed within the 30 sec abort limit, then, with a predetermined probability (probability of reinforcement), either a specified duration of grain was presented (reinforcement duration) or a brief time out (.5 sec houselight off) occurred. The session terminated following 60 trials. No more than 6 trials with the same ITI duration occurred successively.

Between-session comparisons were made on the basis of initial ITI training history and ITI cue condition (cued versus uncued). Independent variables varied on a between-session basis were the cues correlated with the ITI duration, ratio requirement, probability of reinforcement, and reinforcement duration. The independent variable varied on a within-session basis was the ITI duration preceding the S^D .

Baseline ITI Durations and Cue Conditions

Each subject having completed key training started the basic procedure and was assigned to an initial baseline ITI duration and cue condition constituting training history (Table 1). Birds 2469, 2054, and 2055, respectively, were assigned to 5 sec ITI, 20 sec ITI, and 5 and 20 sec ITI uncued training conditions. Subjects with only one ITI training value (e.g., 5 sec ITI) received 60 trials of that value while subjects with two ITI values (5 and 20 sec ITI) received 30 trials of each.

Birds 6066, 5172, and 599, respectively, were assigned to 5 sec ITI, 20 sec ITI, and 5 and 20 sec ITI cued history conditions. The cross initially cued the 5 sec ITI for these three subjects, while during the 20 sec ITI the key remained dark or uncued. Similarly, Birds 1145, 3115, and 5118, respectively, were assigned to 5 sec ITI, 20 sec ITI, and 5 and 20 sec ITI cued history conditions. The cross, however, initially cued the 20 sec ITI for these three subjects, while during the 5 sec ITI the key remained uncued. Early in training the asymmetrically illuminated cue (cross on key versus dark key) was changed to a symmetrically illuminated cue (each ITI duration illuminated red or green). The change resulted from noting increased responding during cross cued ITI's and correlated shorter latencies. Such data were judged to be consistent with an auto-shaping analysis, in terms of differential predictiveness by a conditioned stimulus (CS) (Shwartz & Gamzu, 1977), and the change to

Table 1
Initial ITI Duration and Cue Condition
for Each Subject

Subjects	Baseline ITI	ITI Cue Condition ^a
1145	5 sec	Dark key/green key
6066	5 sec	Cross key/red key
2469	5 sec	Dark key
3115	20 sec	Cross key/red key
5172	20 sec	Dark key/green key
2054	20 sec	Dark key
5118	5 sec and 20 sec	Dark key/green key Cross key/red key
599	5 sec and 20 sec	Cross key/red key Dark key/green key
2055	5 sec and 20 sec	Dark key Dark key

^aCues listed following a virgule (/) indicate the new cue for that ITI intended to avoid the possible autoshaping effect noted with the cue preceding the virgule.

the symmetrically illuminated cue was intended to reduce the relevance of an autoshaping analysis of the experimental results. Specifically, Birds 6066, 5172, and 599 had 5 sec ITI's cued Red and 20 sec ITI's cued Green while the cueing of the ITI's for Birds 1145, 3115, and 5118 was just the opposite (Table 1).

Baseline Manipulations

Reinforcement duration, probability of reinforcement, and ratio requirements constituted the variables manipulated for the nine subjects during baseline. Initially, all subjects began with a ratio requirement of one response (1), probability of reinforcement of 100% (1.0), and duration of reinforcement of 4 sec (4") access to grain (1/1.0/4").

Following at least five sessions the duration of reinforcement was changed from 1/1.0/4" to 1/1.0/3". Subsequent baseline changes in the three parameters of reinforcement occurred following five sessions per condition (Table 2). One parameter of reinforcement was varied per condition change. The sequence of manipulations in the parameters of reinforcement for the nine subjects was: 1.1.0/3", 1/.7/3", 3/.7/3", 7/.7/3". When the parametric values of 7/.7/3" had been reached by each subject and the stability criterion (specified below) had been met, subsequent ITI, ratio requirement, and cue manipulations began.

Table 2
All Condition Changes by Session for Each Subject

Conditions	Subjects								
	1145	3115	5118	6066	5172	599	2469	2054	2055
Baseline									
1/1.0/4"	1-10	1-10	1-10	1-4	1-3	1-4	1-9	1-9	1-6
1/1.0/3"	11	11	16	10	0	12	10	10	7
Color Cue	17	17	11	5	4	5	----	----	----
1/.7/3"	22	22	21	15	14	17	15	15	12
3/.7/3"	27	27	26	20	19	22	20	20	17
7/.7/3"	32	32	31	28	24	28	28	28	25
ITI, Ratio Requirement and Cue Manipulations									
Cues Reversed	----	----	49	----	----	41	----	----	----
Add 5" ITI	----	50	----	----	42	----	----	43	----
Add 20" ITI	54	----	----	40	----	----	43	----	----
1/.7/3"	68	66	66	54	55	57	63	61	40
7/.7/3"	85	92	85	77	78	80	73	71	--
15/.7/3"	103	110	105	93	97	99	----	----	----
1/.7/3"	114	127	116	109	107	113	83	81	----
Catch Trials: Test I	131	----	131	----	125	----	----	----	----
Test II	132	----	130	----	123	----	----	----	----
Test III	133	----	132	----	124	----	----	----	----
Uncued ITI's	----	138	----	125	----	125	----	----	----
ITI's Cued	----	----	----	----	----	----	98	97	----
Both ITI's with Same Cue	134	----	133	----	126	----	----	----	----

ITI, Ratio Requirement, and Cue Manipulations

The addition of 20 sec ITI trials for Subjects 1145, 6066, and 2469; the addition of 5 sec ITI trials for Subjects 3115, 5172, and 2054; and the reversal of cues for Subjects 5118 and 599 constituted the first experimental manipulations for each subject. Subsequent changes for the nine subjects and the initial change for Bird 2055 involved varying the value of the response requirement (see Table 2). Specifically, for the six pigeons with cued ITI's (1145, 3115, 5118, 6066, 5172, and 599) the ratio requirement was changed in the following order to 1, 7, 15, 1 and for the three pigeons with uncued ITI's (2469, 2054, and 2055) it was changed in the following order to 1, 7, 1.

Subjects 1145, 5172, and 5118 with cued ITI's, following the ratio requirement manipulations, were given three one-session tests involving "catch trials" (Stebbins, 1970, p. 56). Catch trials involved following the cued ITI with some stimulus change other than the S^D to ascertain whether the onset of the S^D or some other variable was responsible for the emission of the first response. For Test I the ITI was followed by a dark key. Catch trials for Test II consisted of the ITI followed by a .05 sec flicker and continuation of the cue. Test III included catch trials with one cue followed by the other cue color instead of the S^D . Catch trials occurred on 30% of the 60 trials in a session. Following testing these three

pigeons were placed on a procedure where the cues for both ITI values were the same hue.

Subjects 2469 and 2054, following manipulations of the ratio requirement, were exposed to cued ITI's. Subjects 3115, 6066, and 599, following manipulation of the ratio requirement, were exposed to uncued ITI's.

Such manipulations occurred, following a minimum of 10 sessions on a given condition, with the last five data points showing neither an increasing nor decreasing trend or a trend in the opposite direction of that expected from the subsequent manipulation.

Dependent Variables

Sequential response latencies with codes were recorded. Individual latencies were coded for the preceding ITI duration, whether the subsequent response ratio was completed within the 30 sec abort limit and whether or not that trial had resulted in reinforcement. A latency distribution for each ITI value was also collected in semi-log bins (Michael, Note 1), permitting the computation of extrapolated median latency which served as the primary dependent variable for this study. The semi-log latency distribution began with a bin width of .05 sec which when multiplied by a constant (1.2) formed the next bin. The 16 remaining bins were formed by multiplying the resulting bin width by the constant to create the next bin width, and so on. The direct observation event recorder was used to

document the subject's behavior in the chamber. Recorded was the subject's time 10 cm away from the response key, responses to the intelligence panel during the ITI, reinforcement time, and time outs.

RESULTS

Figures 2 through 10 present median latency as a function of sessions for individual subjects; the two graphs within each figure are distinguished by the within-session differences in ITI duration preceding the stimulus presentation. These median latencies were calculated from the semi-log frequency distributions recorded during each session.

Subjects 1145 and 6066 (Figures 2 and 3, respectively), with cued 5 sec ITI histories, following the introduction of differentially cued 20 sec ITI trials developed a separation in median latencies as a function of the ITI preceding the S^D . For these two subjects the 5 sec ITI trials had the shorter latencies while the 20 sec ITI trials had longer latencies.

For Subject 2469 (Figure 4), with an uncued 5 sec ITI history, following the introduction of uncued 20 sec ITI trials no clear separation of median latencies occurred; however, 5 sec ITI latencies tended to be shorter than 20 sec ITI latencies.

With the removal of cues during the ITI for Subject 6066 and the identical cueing of both ITI values for 1145, the separation of median latencies reversed for the former and became attenuated for the latter. That is, for Bird 6066 the median latencies preceded by 20 sec ITI's became shorter than those preceded by 5 sec ITI's, as contrasted with the cued ITI condition.

Figure 2. Median session latencies for Subject 1145 with a cued 5 sec ITI training history. (Closed circles are median latencies preceded by 5 sec ITI's while open circles are median latencies preceded by 20 sec ITI's. Vertical lines separate different phases of the study. The new conditions corresponding to each phase are represented at the top of each figure. The three numbers at the top of some phases represent, from top to bottom, the ratio requirement, probability of reinforcement, and duration of reinforcement.)

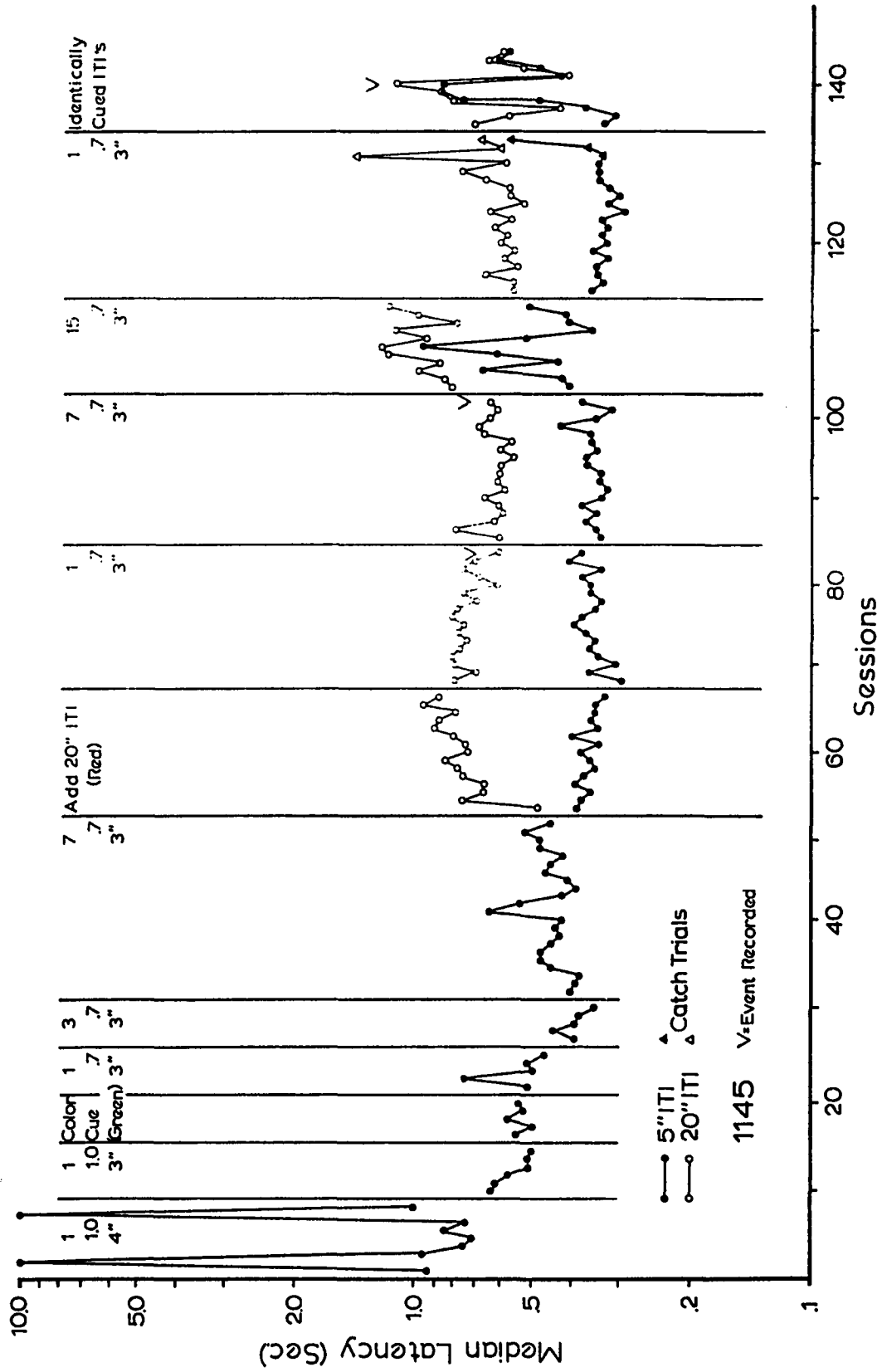

Figure 3. Median session latencies for Subject 6066 with a cued 5 sec ITI training history. (Closed circles are median latencies preceded by 5 sec ITI's while open circles are median latencies preceded by 20 sec ITI's. Vertical lines separate different phases of the study. The new conditions corresponding to each phase are represented at the top of each figure. The three numbers at the top of some phases represent, from top to bottom, the ratio requirement, probability of reinforcement, and duration of reinforcement.)

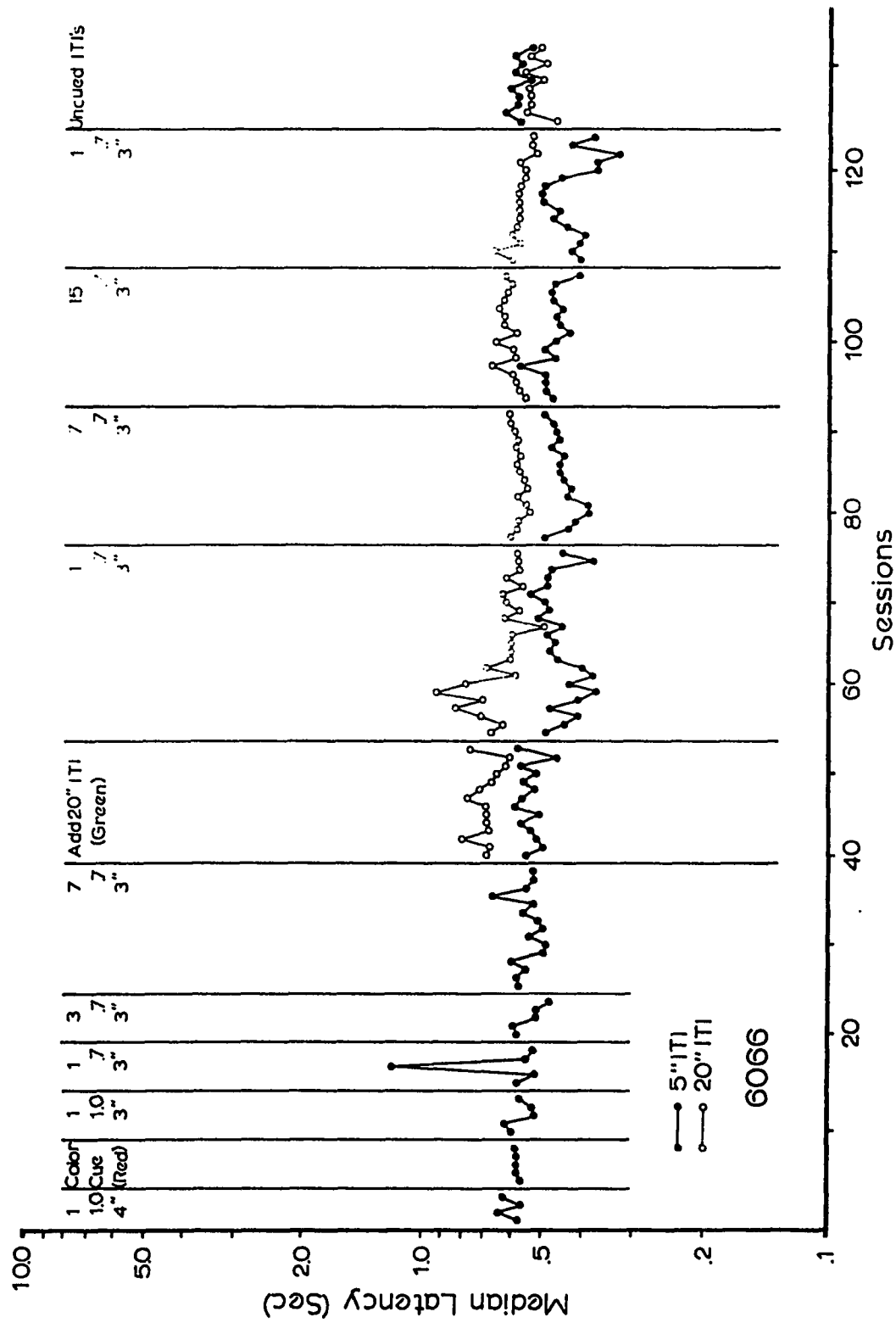
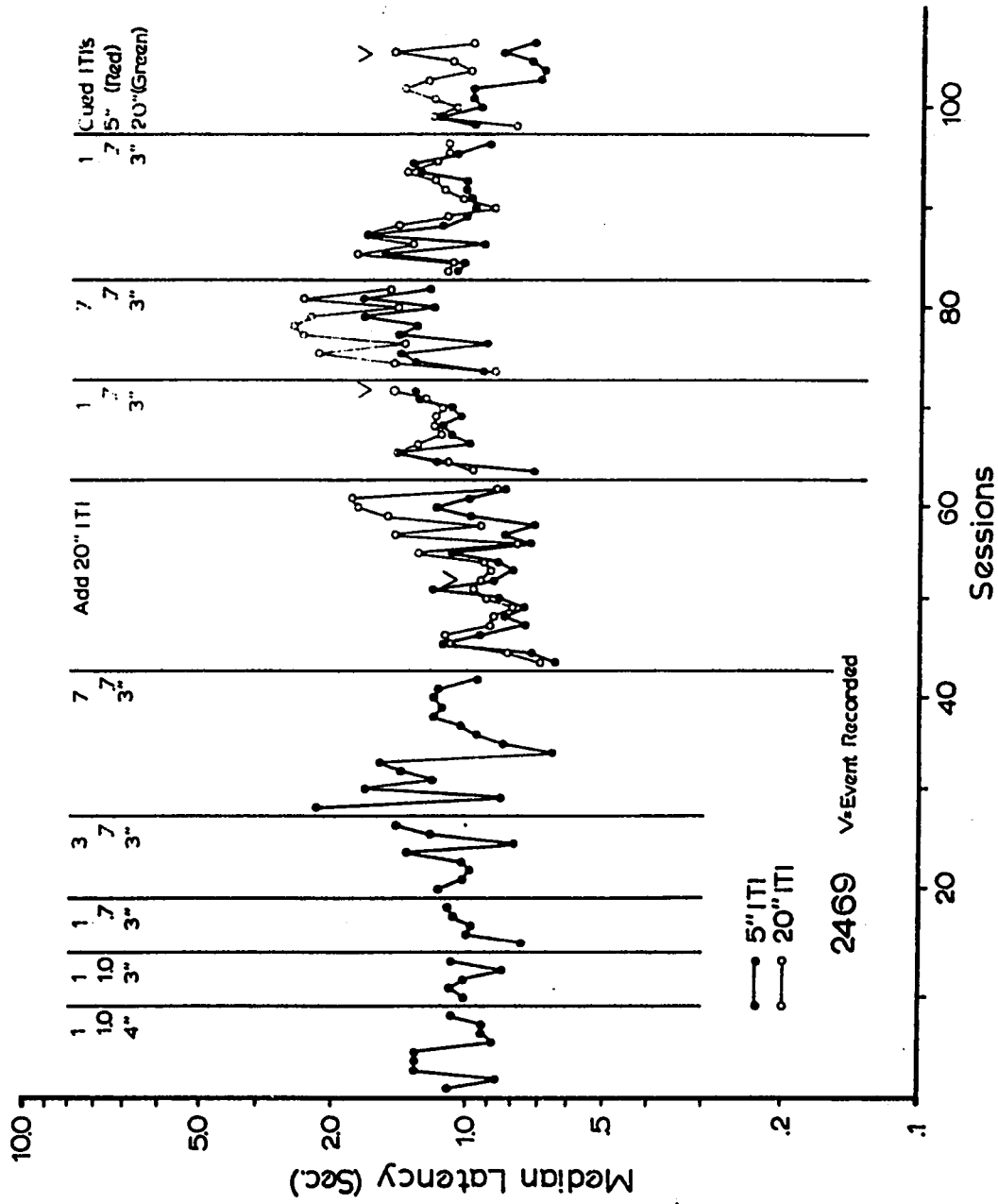

Figure 4. Median session latencies for Subject 2469 with an uncued 5 sec ITI training history. (Closed circles are median latencies preceded by 5 sec ITI's while open circles are median latencies preceded by 20 sec ITI's. Vertical lines separate different phases of the study. The new conditions corresponding to each phase are represented at the top of each figure. The three numbers at the top of some phases represent, from top to bottom, the ratio requirement, probability of reinforcement, and duration of reinforcement.)



With the introduction of differentially cued ITI's for Subject 2469 a clear and stable separation in median latencies developed with the shorter latencies preceded by 5 sec ITI's similar to the separations for Subjects 1145 and 6066 during cued ITI conditions.

Manipulations of the ratio requirement (RR) typically had no clear systematic effect on the median latencies of these three subjects (Figures 2, 3, and 4). The only clear effects were for Subjects 1145 and 6066 in which, for both ITI's, latencies increased with the change to a RR of 15 for the former and a transitory increase in the separation of median latencies with a RR of 1 for the latter.

The introduction of the differentially cued 5 sec ITI trials for Subjects 3115 and 5172 (Figures 5 and 6, respectively), with 20 sec cued ITI histories, resulted in a slowly developing, relatively small and variable separation in median latencies. For these two subjects the median latencies preceded by 5 sec ITI's were shorter than those preceded by 20 sec ITI's.

However, for 2054 (Figure 7), with an uncued 20 sec ITI history, the introduction of 5 sec ITI's resulted in a separation of median latencies with shorter latencies preceded by 20 sec ITI's. The separation developed immediately and was stable.

The removal of cues during ITI's for 3115 and the identical cueing of both ITI's for 5172 resulted in the reversal of the separation in median latencies for both subjects such that the shorter median latencies were preceded by 20 sec ITI's. The introduction of cued

Figure 5. Median session latencies for Subject 3115 with a cued 20 sec ITI training history. (Closed circles are median latencies preceded by 5 sec ITI's while open circles are median latencies preceded by 20 sec ITI's. Vertical lines separate different phases of the study. The new conditions corresponding to each phase are represented at the top of each figure. The three numbers at the top of some phases represent, from top to bottom, the ratio requirement, probability of reinforcement, and duration of reinforcement.)

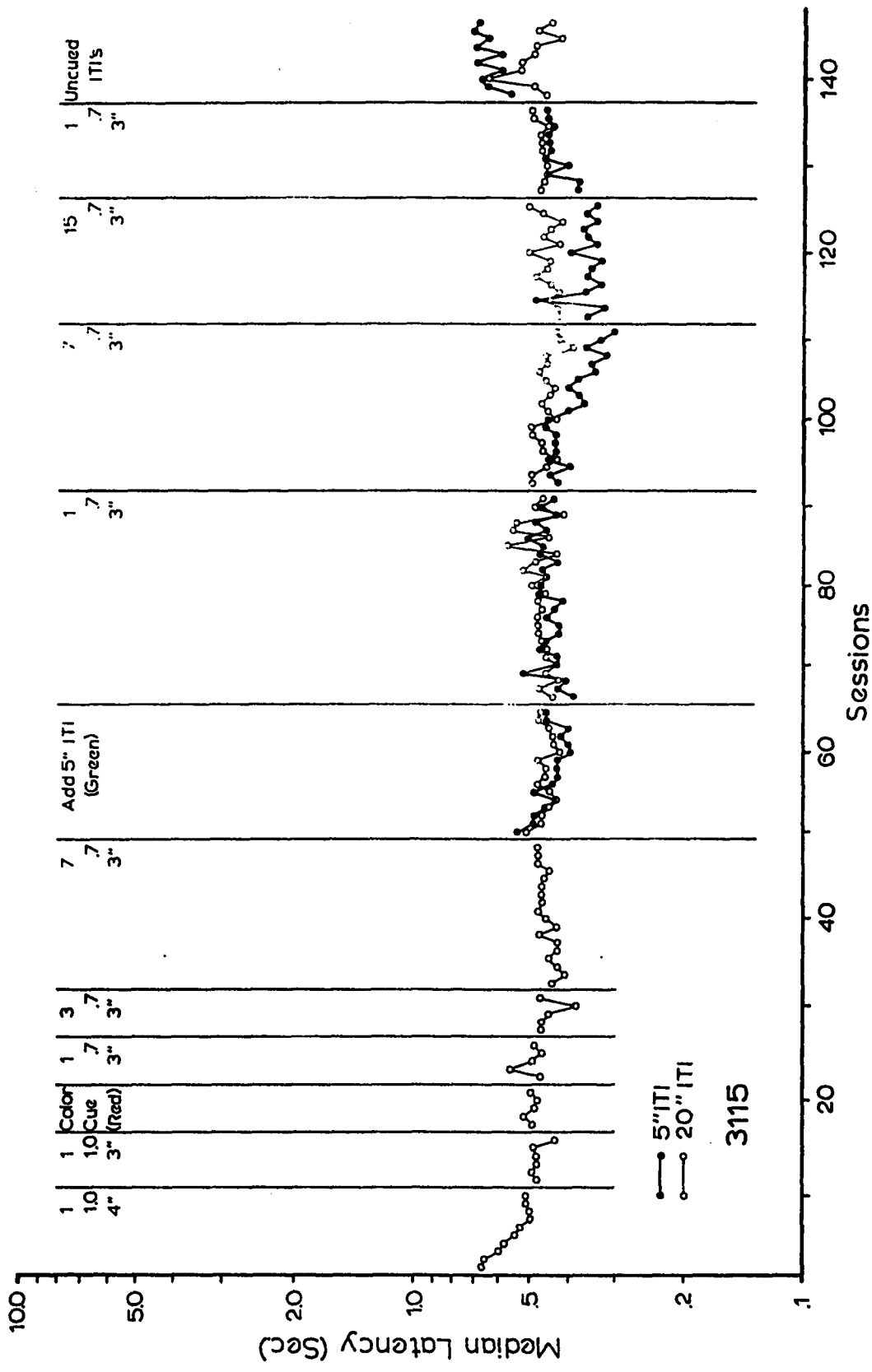

Figure 6. Median session latencies for Subject 5172 with a cued 20 sec ITI training history. (Closed circles are median latencies preceded by 5 sec ITI's while open circles are median latencies preceded by 20 sec ITI's. Vertical lines separate different phases of the study. The new conditions corresponding to each phase are represented at the top of each figure. The three numbers at the top of some phases represent, from top to bottom, the ratio requirement, probability of reinforcement, and duration of reinforcement.)

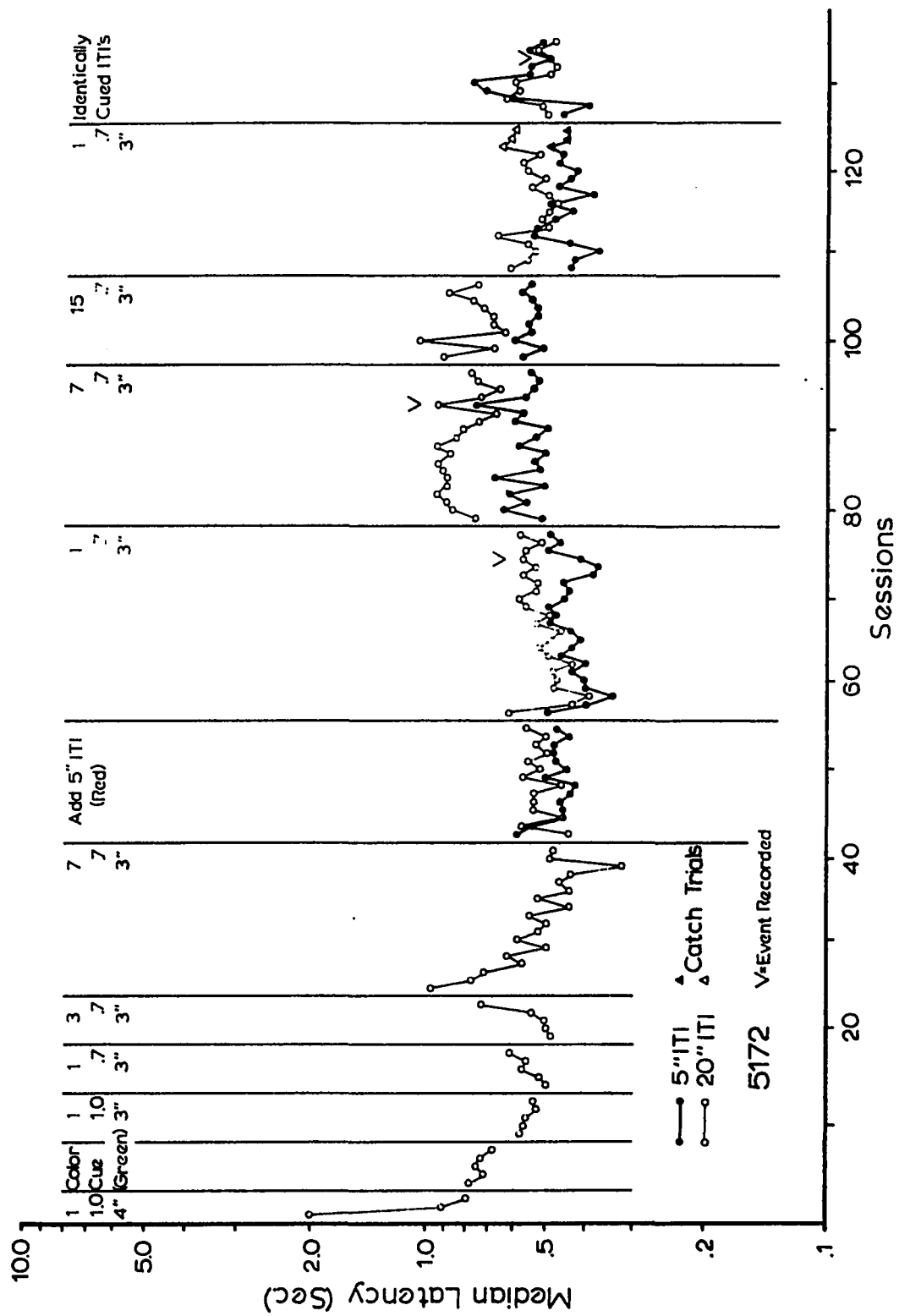
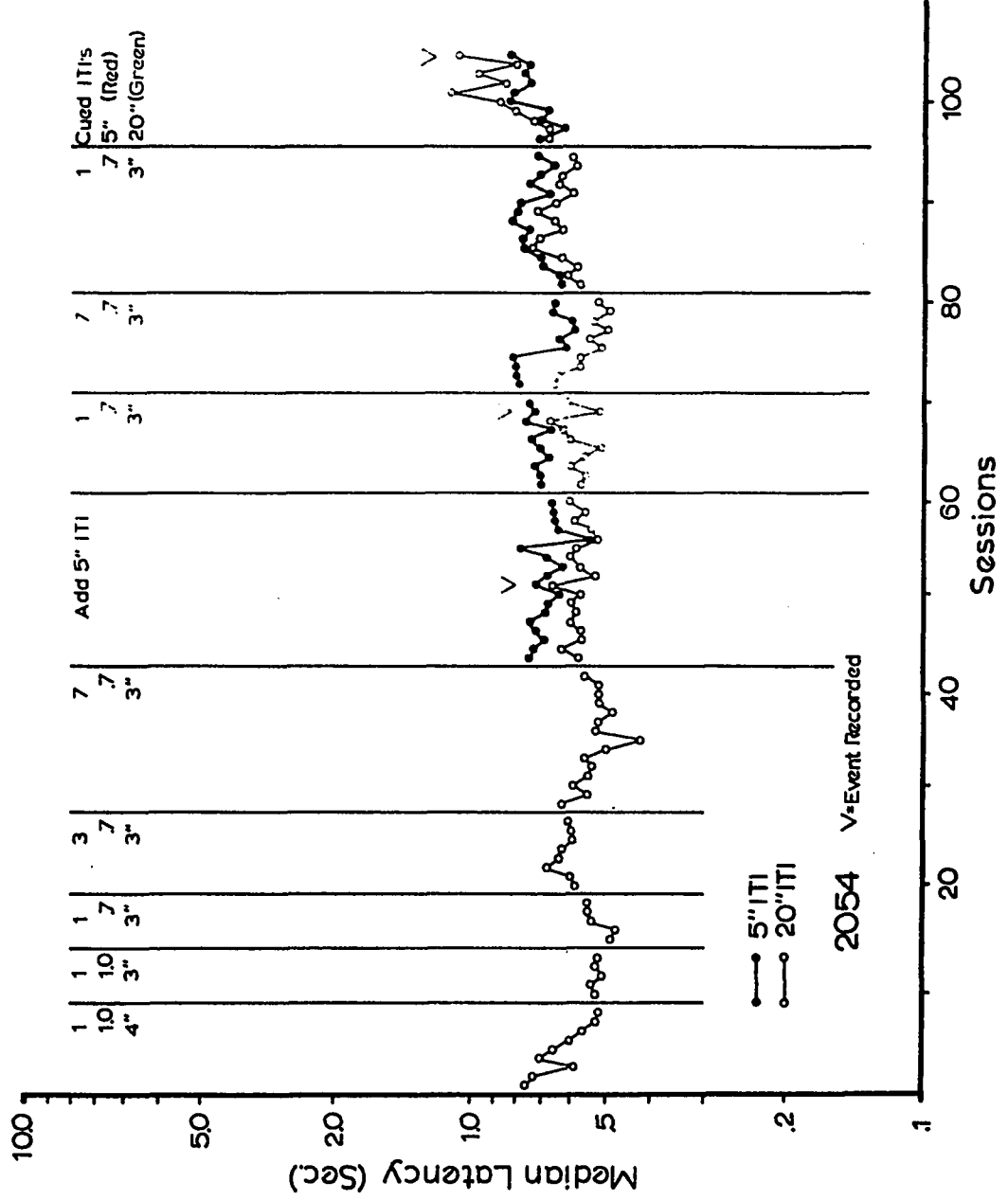

Figure 7. Median session latencies for Subject 2054 with an uncued 20 sec ITI training history. (Closed circles are median latencies preceded by 5 sec ITI's while open circles are median latencies preceded by 20 sec ITI's. Vertical lines separate different phases of the study. The new conditions corresponding to each phase are represented at the top of each figure. The three numbers at the top of some phases represent, from top to bottom, the ratio requirement, probability of reinforcement, and duration of reinforcement.)



ITI's for 2054 (Figure 7), similarly, resulted in the reversal of median latencies such that the shorter latencies were preceded by 5 sec ITI's.

Manipulation of the RR systematically affected the median latencies for Subjects 3115 and 5172, but not Subject 2054. For the former two subjects ratio requirements of 7 and 15 were correlated with the larger separations in the median latencies between ITI conditions while a RR of 1 attenuated the separation. Additionally, the median latencies following both ITI values for Subject 5172 increased with an increase in the RR to 7.

Subjects 5118 and 599 (Figures 8 and 9, respectively), with 5 and 20 sec cued ITI histories, developed separations in median latencies. These separations, however, were highly variable. For 5118 the shorter median latencies were preceded by 20 sec ITI's when a clear separation was present. In contrast, Subject 599 maintained shorter median latencies when preceded by 5 sec ITI's. In addition, the reversal of cues correlated with each ITI value did not affect the different ITI median latencies.

Subject 2055 (Figure 10), with a 5 and 20 sec uncued ITI history, also developed a separation in median latencies. The separation was relatively small but stable with the shorter latency preceded by 5 sec ITI's.

The identical cueing of both ITI's for 5118 and the removal of cues during the ITI's for 599 resulted in the attenuation of the

Figure 8. Median session latencies for Subject 5118 with a cued 5 and 20 sec ITI training history. (Closed circles are median latencies preceded by 5 sec ITI's while open circles are median latencies preceded by 20 sec ITI's. Vertical lines separate different phases of the study. The new conditions corresponding to each phase are represented at the top of each figure. The three numbers at the top of some phases represent, from top to bottom, the ratio requirement, probability of reinforcement, and duration of reinforcement.)

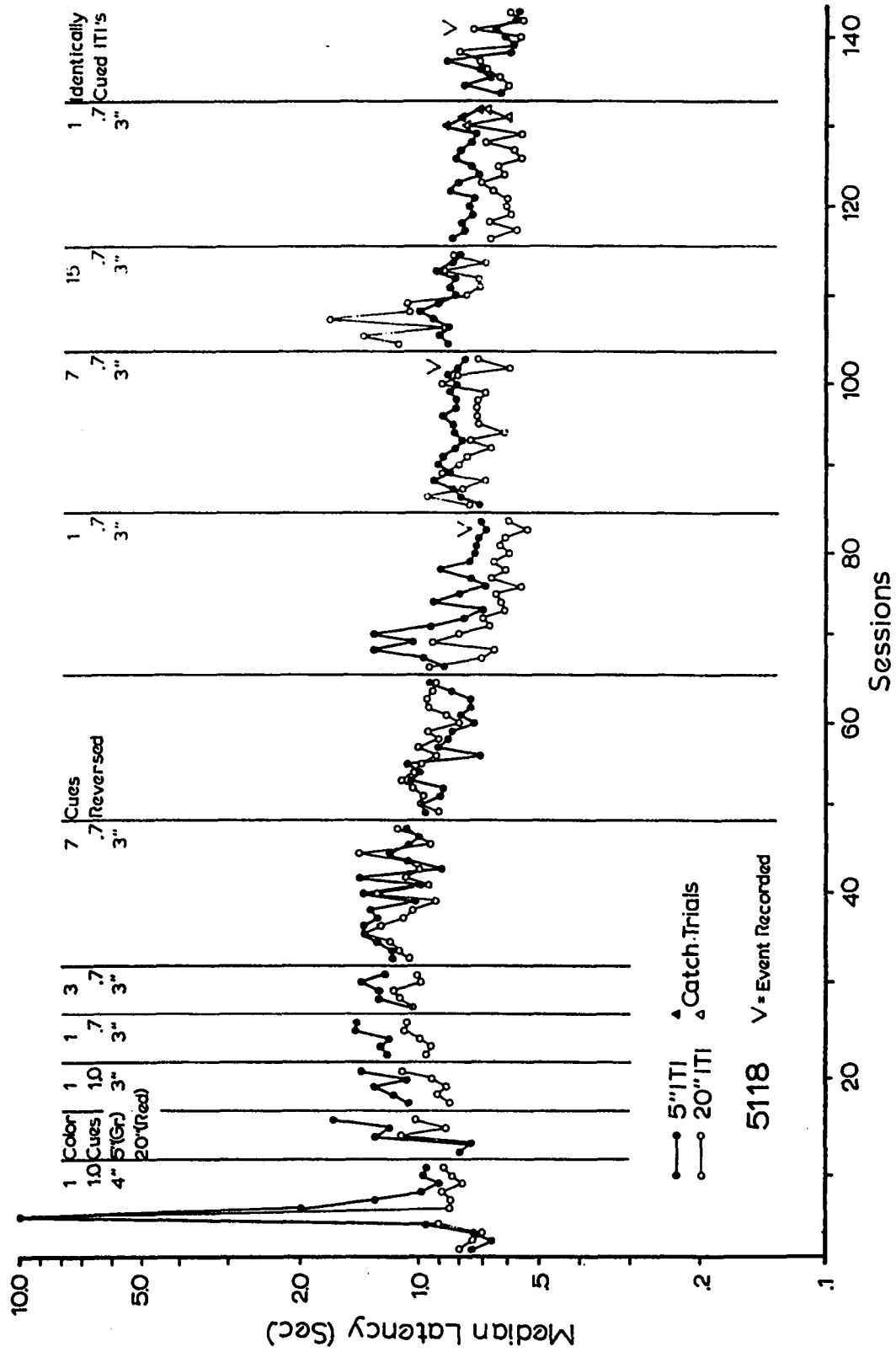

Figure 9. Median session latencies for Subject 599 with a cued 5 and 20 sec ITI training history. (Closed circles are median latencies preceded by 5 sec ITI's while open circles are median latencies preceded by 20 sec ITI's. Vertical lines separate different phases of the study. The new conditions corresponding to each phase are represented at the top of each figure. The three numbers at the top of some phases represent, from top to bottom, the ratio requirement, probability of reinforcement, and duration of reinforcement.)

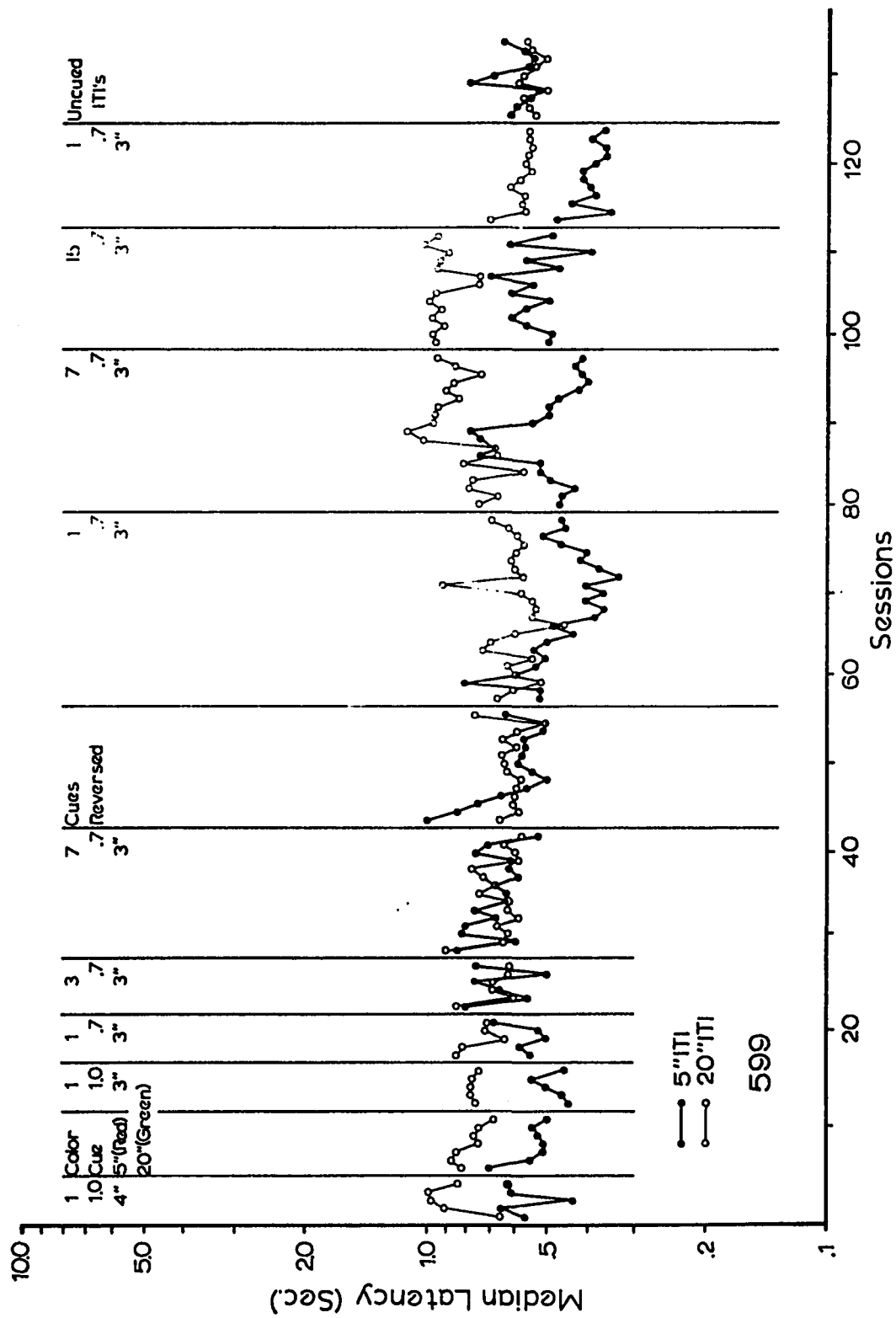
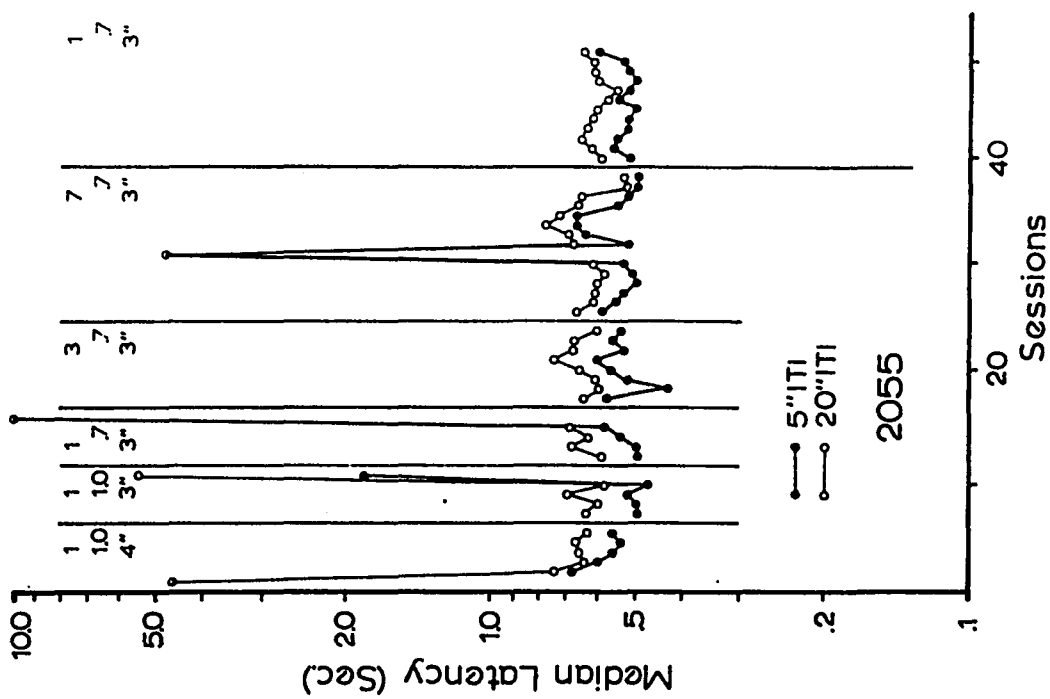

Figure 10. Median session latencies for Subject 2055 with an uncued 5 and 20 sec ITI training history. (Closed circles are median latencies preceded by 5 sec ITI's while open circles are median latencies preceded by 20 sec ITI's. Vertical lines separated different phases of the study. The new conditions corresponding to each phase are represented at the top of each figure. The three numbers at the top of some phases represent, from top to bottom, the ratio requirement, probability of reinforcement, and duration of reinforcement.)



separation for the former and the reversal of the separation for the latter. The death of 2055 did not permit the introduction of cued ITI's.

The manipulation of the RR systematically affected the median latencies for Subjects 5118 and 599. Initial increases in the RR attenuated the separation for these two subjects. Subsequent reduction in the RR to 1 resulted in the recovery of the separation for 5118 and 599. Further increases in the RR to 7 and 15 again attenuated the separation for 5118; however, attenuation is less evident for 599 (see Figures 8 and 9). For 599 the increase in the RR, additionally, increased both ITI median latencies. With the return to a RR of 1 the separation was regained for 5118 and stabilized, with both 5 sec and 20 sec ITI latencies shortening, for 599. Manipulations in RR value had no effect upon 2055's latencies.

Characteristic samples of within-session event recordings for five subjects--1145, 5172, 5118, 2469, and 2054--are presented in Figure 11. Three samples, each from three different experimental conditions, for each subject are presented. In addition, Table 3 presents the mean time spent 10 cm from the response key and the mean rate of pecking toward the intelligence panel for each of the subject's three experimental sessions from which the samples (Figure 11) were derived. Included are similar measures (Table 3) computed from the sample data as an indication of the samples' representativeness of the entire session. Three variables were recorded in each session:

Figure 11: Sample within-session event recordings for five subjects under three different experimental conditions. (The three events recorded each session were: on the first channel, time 10 cm away from the response key; on the center channel, pecks toward the intelligence panel; and on the last channel, reinforcements and time outs. The occurrence of each event is indicated by the upward deflection of the pen on the corresponding channel. Parameters of reinforcement of 7/.7/3" are represented by "A"; "B" represents the parameters of 1/.7/3". The numbers "0", "1", and "2" indicate uncued ITI's, cued ITI's, and identically cued ITI's, respectively.)

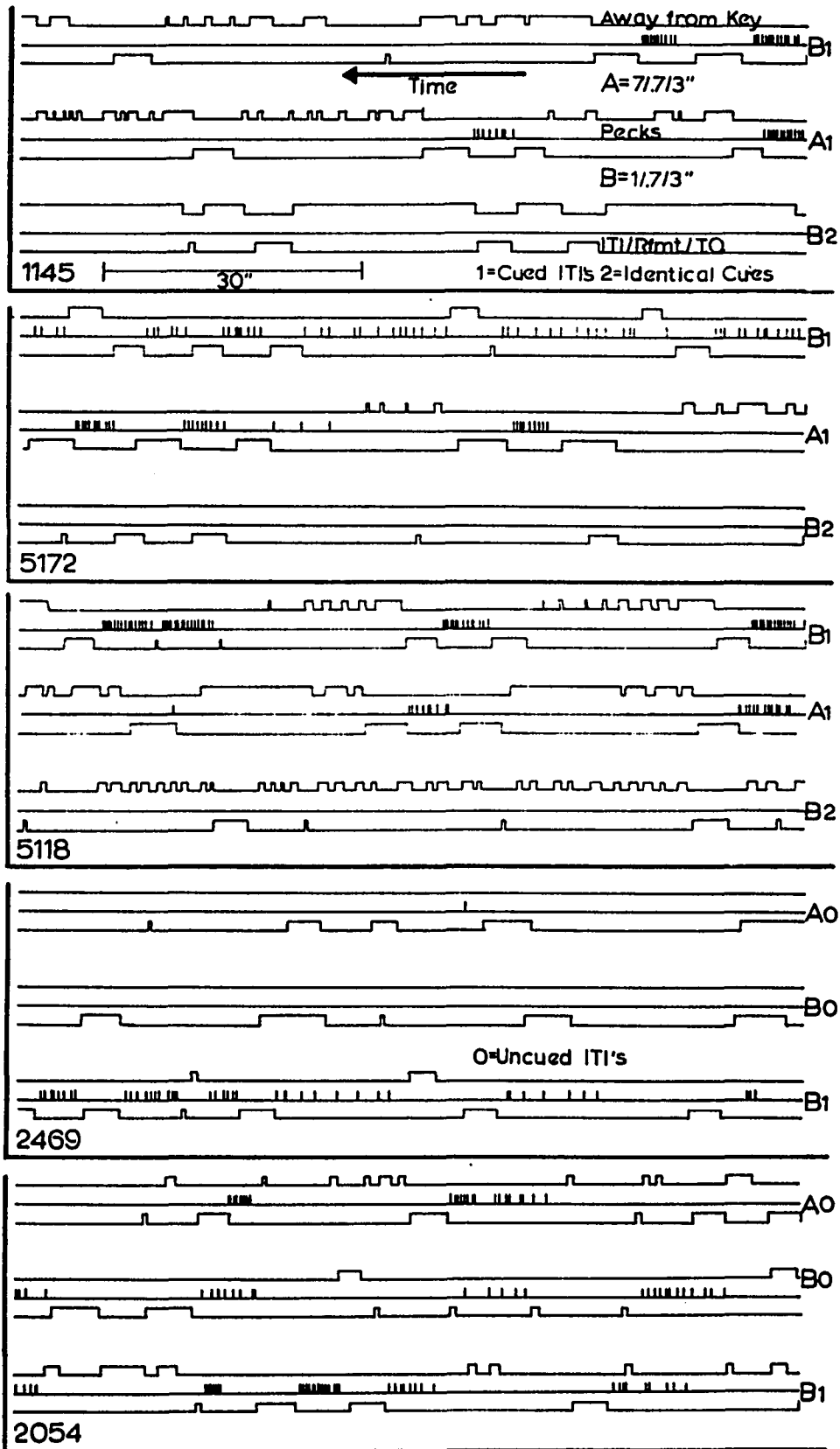

Table 3

Session Means and Sample Means for Event-Recorded Sessions

Subjects	1145		5172		5118		2469		2054	
Session conditions ^a	B1		B1		B1		A0		A0	
ITI's	5"	20"	5"	20"	5"	20"	5"	20"	5"	20"
Session mean; Time away from key	0"	28"	0"	18"	0"	32"	0"	.5"	28"	14"
Sample; Time away from key	0"	28"	0"	9"	0"	26"	0"	0"	23"	18"
Session mean; Rate of pecks to panel	124	0	132	12	133	0	.5	0	86	26
Sample; Rate of pecks to panel	132	0	92	9	102	0	.3	0	72	27
Session conditions	A1		A1		A1		B0		B0	
Session mean; Time away from key	0"	34"	0"	16"	0"	45"	0"	0"	0"	6"
Sample; Time away from key	0"	37"	0"	11"	0"	48"	0"	0"	0"	8"
Session mean; Rate of pecks to panel	136	0	128	30	121	.3	0	0	24	33
Sample; Rate of pecks to panel	150	0	116	39	102	1	0	0	20	30
Session conditions	B2		B2		B2		B1		B1	
Session mean; Time away from key	52"	57"	0"	0"	31"	32"	1"	5"	0"	12"
Sample; Time away from key	48"	55"	0"	0"	23"	35"	3"	6"	0"	8"
Session mean; Rate of pecks to panel	0	0	0	0	0	0	108	23	138	30
Sample; Rate of pecks to panel	0	0	0	0	0	0	102	21	144	23

Note. Time (sec/min) 10 cm away from response key; rate (pecks/min) towards intelligence panel

^aA=rfmt parameters 7/.7/3"; B=rfmt parameters 1/.7/3"; 0=uncued ITI's; 1=cued ITI's; 2=same cued ITI's

on the first channel, the time the subject was 10 cm from the response key; on the second channel, pecks toward the intelligence panel and/or toward the response key during the ITI; and on the third channel, reinforcement and time out times.

For Birds 1145, 5172, and 5118, two sessions had cued ITI's, one with reinforcement parameters of 1/.7/3" and the other with 7/.7/3". The third session for these three subjects had identically cued ITI's with reinforcement parameters of 1/.7/3". For Subjects 2469 and 2054, two sessions had uncued ITI's, one with reinforcement parameters of 1/.7/3" and the other with 7/.7/3". The third session for these two subjects had cued ITI's with reinforcement parameters of 1/.7/3".

Subjects 1145, 5172, and 5118, with cued ITI's, developed specific response patterns correlated with each ITI value. During 20 sec ITI's the three subjects spent time away from the response key which did not occur during 5 sec ITI's. The three subjects pecked toward the intelligence panel, with increasing frequency as time passed, during the 5 sec ITI's. Only Subject 5172 pecked at a high rate during the 20 sec ITI's. With a change in the RR from 7 to 1 there was a correlated change in the response pattern. For Birds 1145 and 5118 time away from the key during 20 sec ITI's decreased while it remained relatively unchanged for 5172. With the identical cueing of ITI's for 1145, 5172, and 5118, time away from the key was similar in both ITI's. Additionally, pecking during ITI's no longer

occurred and time away from the key now occurred during 5 sec ITI's for Birds 1145 and 5118.

For Subjects 2469 and 2054 two of the sessions had uncued ITI's with parameters of reinforcement of $1/.7/3$ " for one session and $7/.7/3$ " for the other. The third session for these subjects had cued ITI's with reinforcement parameters of $1/.7/3$ ".

Subject 2469, with ITI's uncued, developed no stereotypic response pattern correlated with each ITI value. In contrast, 2054, again with uncued ITI's, developed specific response patterns correlated with each ITI. Moreover, with the change in the RR from 7 to 1, periods of time away from the key decreased as well as the rate of pecking during the ITI for 2054. With the introduction of cued ITI's 2469 and 2054 developed specific response patterns correlated with each ITI.

In regard to the catch trial test session for 1145, 5172, and 5118 with cued ITI's only Subject 5172 responded on any of the catch trials. Subject 5172 responded on two trials during Test II, on which a .05 sec cue flicker and cue continuation occurred instead of the presentation of the S^D . Latencies for both catch trial responses were over 9 sec as measured for the .05 sec flicker.

DISCUSSION

Response latency varied as a function of the ITI preceding the onset of the S^D . Initial ITI training generally determined the degree of difference between the latencies preceded by the 5 sec ITI's and 20 sec ITI's (e.g., subjects with the cued 5 sec ITI histories developed the largest relative separations in median latencies). In addition, the effects of manipulations of the RR were correlated with ITI training. With changes in the RR for subjects with cued 20 sec and 5 and 20 sec ITI histories latency separations were attenuated; this was not evident for the subjects with cued 5 sec ITI histories.

The presence or absence of differentially cued ITI's (different cues correlated with each ITI duration) altered the effect of the preceding ITI on the subsequent latency and possibly the effects of RR manipulations. Subject 2469, with an uncued ITI training history, did not develop a clear separation in latencies until cues during the ITI's were introduced. For Subject 2045, also with an uncued history, the introduction of cues reversed the previously developed separation. For the subjects with cued ITI histories, the removal of a differential cue either attenuated the latency separation or reversed it. Also, manipulations in the RR had no effect on the degree of separation or absolute value of median latencies for 2054 and 2055 with uncued histories.

The development of stereotypic response patterns correlated with each ITI value resembles that often observed under differential reinforcement of low rate (DRL) schedules of reinforcement (Blackman & Scruton, 1972; Hodos, Ross, & Brady, 1962; Laties, Weiss, Clark, & Reynolds, 1965; Laties, Weiss, B., & Weiss, A., 1969; McMillian, 1969; Snapper, Ramsay, & Schoenfeld, 1969) in delayed match to sample (Blough, 1959) and delayed alternation schedules (Hearst, 1962). The common factor in these various paradigms is the experimentally specified passage of time without the occurrence of the experimenter specified response.

The stereotypic behaviors observed during the passage of time are often thought of as collateral responding or behavior "used by the organism as a controlling stimulus in subsequent behavior" (Ferster & Skinner, 1957, p. 729) which mediates time passage until the moment a contingency specified response will result in reinforcement. That is, collateral responding mediates the emission of temporally differentiated responses. Disruption of collateral response patterns has been demonstrated to disrupt temporally differentiated responses (Hodos, Ross, & Brady, 1962; Laties, Weiss, Clark, & Reynolds, 1965; Snapper, Ramsay, & Schoenfeld, 1969).

The discrete trial procedure utilized in this study may be considered a schedule which differentially reinforces temporal responding (e.g., DRL). The ITI with its differential reinforcement of other behavior contingency (DRO) for ITI keypeck responding

defines a reinforcement contingency specifying that the first key response (if the RR is 1) following a given period of time (ITI duration) results in reinforcement.

The first difficulty with such an analysis is accounting for which ITI duration is followed by the shorter latencies. Catania (1970) using the differential reinforcement of long latencies (DRLL) found with short DRLL's (e.g., 5 sec) pigeons tend to underestimate the passage of time while with longer DRLL's (e.g., 20 sec) they tended to overestimate time passage. That is, for shorter DRLL's the mean latency exceeded the temporal contingency while with longer DRLL's the mean latency was below the specified temporal contingency. Given such results, it would be expected that in the present study the latencies preceded by 5 sec ITI's, if temporally controlled, would be longer than those preceded by 20 sec ITI's; the opposite was typical, however.

The second difficulty of a temporal analysis arises when the catch trial data are considered. Since no responses occurred on catch trials which were similar in latency to the typical trial latencies, the variable controlling the emission of the key response was the onset of the S^D and not the passage of time.

Another possible interpretation of the stereotypic responding during ITI's can be made in terms of "species specific behavior" controlled in a manner similar to respondent behavior (Rand, 1977; Staddon & Simmelhas, 1971; Staddon, 1977). Such an analysis would

state that the ITI cue condition correlated with different probabilities of reinforcement elicit appropriate differential species specific response patterns.

This analysis in terms of species specific response patterns does not account for the systematic changes in the response pattern with changes in the RR and changes in the cue condition. The two ITI values were always correlated with the same probability of reinforcement; therefore, the same response pattern should be elicited no matter what the correlated cue condition was and the same pattern should be elicited for all subjects. However, neither of these events was noted.

Perhaps a better speculative analysis may now be made in terms of "superstitious" behavior (Skinner, 1961). Behavior not specified by a reinforcement contingency may become conditioned through the adventitious relation between the occurrence of the response and the delivery of reinforcement. Additionally, superstitious behavior can come to be controlled by an antecedent stimulus (sensory superstition) through the adventitious reinforcement of the response in the presence of a given stimulus (Skinner, 1961).

In the experimental procedure the delivery of reinforcement following the completion of the RR might not only strengthen responding to the key in the presence of the S^D but also any responding prior to it in the presence of the ITI cue. Since the ITI was correlated with a DRO contingency for response key pecks, any other responses occurring

during the ITI would tend to be reinforced with the presentation of the S^D , as conditioned reinforcement, and the delivery of grain.

For example, when cued 5 sec ITI trials were introduced, pecks to the response key during the ITI occurred. As a function of the ITI's DRO contingency, the rate of pecks on the response key closing the key's microswitch during the ITI decreased to the point on a given trial that 5 sec transpired resulting in S^D presentation and subsequent grain delivery. Such reinforcement would adventitiously condition other behavior prior to S^D onset (e.g., standing near the intelligence panel) including the pecking of or towards the response key during the ITI. Such a pattern of responding was typical of cued 5 sec ITI's (Figure 11). That is, a high rate of pecks toward the response key without closing the key's microswitch and little or no time spent away from the key occurred.

When cued 20 sec ITI trials were introduced pecking the response key during the ITI also occurred. Logically, response key pecking closing the key's microswitch during the ITI would be weakened more during the 20 sec ITI than during the 5 sec ITI, so that 20 sec may transpire, resulting in the S^D presentation and grain delivery. The greater extinction of response key pecking during the ITI and its distance from reinforcement would result in the relative absence of pecking towards the key during the 20 sec ITI. The longer ITI would also provide the opportunity for more and varied responding (e.g., subject's movement away from the intelligence panel) and its

superstitious conditioning. Additionally, with continued exposure to 20 sec cued ITI's the cue at the beginning of the ITI may function as an S- for response key pecking, as a function of being correlated with the lowest momentary probability of reinforcement. Again, such patterns of responding were typical of cued 20 sec ITI's (Figure 11). That is, there was a relatively low rate of pecking towards the response key and more time spent away from the response key during the ITI.

With respect to uncued ITI's the analysis of the stereotypic responding in terms of sensory superstitious behavior is more complex. Presumably with cued ITI's a specific response pattern comes under the discriminative control of the cue correlated with each ITI value. Discriminative control by different uncued ITI's is initially the same (when both durations are programmed). However, after 5 sec either the S^D is presented or the interval continues. If the subject's behavior during the initial 5 sec functions as collateral behavior or a discriminative stimulus then discriminative control of superstitious patterns of responding correlated with the 20 sec ITI is possible. Such an analysis is consistent with the response patterns for uncued ITI's (Figure 11). That is, responding during the initial 5 sec of either 5 sec ITI's or 20 sec ITI's is undifferentiated and only becomes so with the subsequent passage of time in 20 sec ITI's.

With respect to the effects of a cued ITI training history on superstitious behaviors during the ITI, training with a single ITI would tend to result in a well-conditioned ITI response pattern. Generally, as a function of stimulus generalization the well-conditioned ITI response pattern would occur during the newly introduced ITI and tend to interfere with the development of an equally effective ITI response pattern resulting in equally short latencies. However, since cued 5 sec ITI's tend to generate IYI behavior resulting in the subject's position close to the response key at the moment of S^D onset, the likelihood of shorter latencies following cued 5 sec ITI's would be greater than with cued 20 sec ITI's. Such an analysis, considering interference and the typical 5 sec ITI response pattern, may account for the difference in relative separations in median latencies between cued 5 sec ITI trained subjects (1145, 6066; Figures 2 and 3) with the larger relative separations and cued 20 sec ITI trained subjects (3115, 5172; Figures 5 and 6) with the smaller relative separations.

For Subject 2054 (Figure 6), with uncued 20 sec ITI training, the introduction of 5 sec ITI trials lacking a cue did not generate pecking during 5 sec ITI's. The lack of ITI key responding may account for the continued relative effectiveness of 20 sec ITI's generating shorter latencies. For 2469 (Figure 4) with uncued 5 sec ITI training, no superstitious response pattern was evident. A necessary condition for the conditioning of superstitious responding is

the passage of sufficient time providing the opportunity for noncontingency specified responses to be emitted. A 5 sec ITI may not be of sufficient duration to provide the opportunity for a nonspecified response to be emitted.

Subjects with a cued 5 and 20 sec ITI training, by chance contingencies, may have had more effective (producing shorter latencies) superstitious response patterns adventitiously conditioned for 5 sec or 20 sec ITI's. Such a chance contingency can be identified for 5118 with cued ITI's (Figure 8). As a function of the cross cue of 20 sec ITI's, early in training, an effective sensory superstitious pattern became conditioned relative to the dark key or uncued 5 sec ITI. Mentioned earlier was the fact that ITI responding was greater for cross cued ITI's than for those that were uncued. Such ITI responding would tend to result in the conditioning of a response pattern similar in effectiveness to that developed during 5 sec ITI's.

The effect of changes in latency as a function of changes in the RR may be considered the result of the altered reinforcing effectiveness of the S^D , as conditioned reinforcement. The altered reinforcing effectiveness of the S^D and change in the gradient of reinforcement would differentially strengthen component behaviors of the ITI response patterns altering the subject's position at the moment of S^D onset. However, such an analysis does not account for the relative insensitivity of subjects with uncued ITI's to changes

in the RR. Perhaps experimental conditions were not of sufficient duration to reveal such effects or perhaps the lack of an extroceptive cue may have been the critical variable.

Response latency on a discrete-trial procedure is partially determined by the ITI duration preceding the onset of the S^D . Specifically, superstitious response patterns determine the subject's position in the chamber at the moment of stimulus onset which affects the length of the subsequent latency. Superstitious ITI response patterns are a function of ITI duration, cue condition, training history, and may be affected by changes in the RR.

If a change in the RR affects superstitious ITI responding then it would be expected that manipulations of other parameters of reinforcement would have a similar effect. Such an effect may confound the experimental results of latency studies involving changes in various parameters of reinforcement. That is, the observed change in latency may be a function of the correlated changes in strength of the first response and changes in the ITI behavior determining the subject's chamber position at the moment of stimulus onset. A Stebbins reaction time (1970) procedure would control the effect of subject position at the moment of S^D onset by requiring a contingency specified foreperiod response.

Factors for further consideration include the replication of the student laboratory experiment which resulted in the attenuation of the separation of response latencies utilizing a reaction time

procedure. Also worth investigating is the apparent insensitivity of latency to changes in the RR with uncued ITI's and subjects with 5 sec ITI training histories. The value of latency as a reliable dependent variable in operant research is dependent on the resolution of concerns such as those previously mentioned.

REFERENCE NOTES

1. Michael, J., Hesse, B., Nuzzo, J., Selman, L., Sundberg, M., & Whitley, P. Latency as a function of the number of responses required, probability of reinforcement, and amount of reinforcement. Manuscript submitted for publication, 1981.
2. Michael, J., Burke, W., Cole, P., Hesse, B., LaLonde, C., Madsen, J., Nuzzo, J., Selman, L., Sundberg, M., & Whitley, P. Operant latency. Poster session presented at the meeting of the Association for Behavior Analysis, Milwaukee, May 1981.

BIBLIOGRAPHY

- Blackman, D., & Scruton, P. Conditioned suppression of counting behavior in rats. Journal of the Experimental Analysis of Behavior, 1972, 19, 93-100.
- Blough, D. S. Delayed matching in the pigeon. Journal of the Experimental Analysis of Behavior, 1959, 2, 151-160.
- Catania, C. A. Reinforcement schedules and psychophysical judgements. In W. N. Schoenfeld (Ed.), The theory of reinforcement schedules. New York: Appleton-Century-Crofts, 1970.
- Cross, D. V., & Lane, H. L. On the discriminative control of concurrent responses: the relations among frequency, latency, and topography in auditory generalization. Journal of the Experimental Analysis of Behavior, 1962, 5, 487-496.
- Dews, P. B. The effect of multiple S periods on responding on a fixed-interval schedule. Journal of the Experimental Analysis of Behavior, 1962, 5, 369-374.
- Dews, P. B. The effect of multiple S periods on responding on a fixed-interval schedule: II. Journal of the Experimental Analysis of Behavior, 1965, 8, 53-54.
- Dews, P. B. The effect of multiple S periods on responding on a fixed-interval schedule: III. Journal of the Experimental Analysis of Behavior, 1965, 8, 427-435.
- Dews, P. B. The effect of multiple S periods on responding on a fixed-interval schedule: IV. Effects of continuous S with only short S probes. Journal of the Experimental Analysis of Behavior, 1966, 9, 147-151.
- Dews, P. B. The effect of multiple S periods on responding on a fixed-interval schedule: V. Effect of periods of complete darkness and of occasional omissions of food presentations. Journal of the Experimental Analysis of Behavior, 1966, 9, 573-578.
- Eckerman, D. A. Generalization and response mediation of a conditional discrimination. Journal of the Experimental Analysis of Behavior, 1970, 13, 301-316.
- Ferster, C. B., & Skinner, B. F. Schedules of reinforcement. New York: Appleton-Century-Crofts, 1957.

- Green, M., Terman, M., & Terman, J. S. Comparison of yes-no latency measures of auditory intensity discrimination. Journal of the Experimental Analysis of Behavior, 1979, 32, 363-372.
- Hearst, E. Delayed alternation in the pigeon. Journal of the Experimental Analysis of Behavior, 1962, 5, 225-228.
- Hienz, R. D., & Eckerman, D. A. Latency and frequency of responding under discrete-trial fixed-interval schedules of reinforcement. Journal of the Experimental Analysis of Behavior, 1974, 21, 341-345.
- Hodos, W., Ross, G. S., & Brady, J. V. Complex response patterns during temporally spaced responding. Journal of the Experimental Analysis of Behavior, 1962, 5, 473-479.
- Holt, G. L., & Shafer, J. N. Function of intertrial interval in matching-to-sample. Journal of the Experimental Analysis of Behavior, 1973, 19, 181-186.
- Innis, N. K., & Staddon, J. E. R. Temporal tracking on cyclic-interval reinforcement schedules. Journal of the Experimental Analysis of Behavior, 1971, 16, 411-423.
- Laties, V. G., Weiss, B., Clark, R. L., & Reynolds, M. D. Overt "mediating" behavior during temporally spaced responding. Journal of the Experimental Analysis of Behavior, 1965, 8, 107-116.
- Laties, V. G., Weiss, B., & Weiss, A. B. Further observations on overt "mediating" behavior and the discrimination of time. Journal of the Experimental Analysis of Behavior, 1969, 12, 43-57.
- McMillian, D. E. Reinforcement contingencies maintaining collateral responding under a DRL schedule. Journal of the Experimental Analysis of Behavior, 1969, 12, 413-422.
- Moody, D. B., Stebbins, W. C., & Iglauer, C. Auditory generalization gradients for response latency in monkeys. Journal of the Experimental Analysis of Behavior, 1971, 16, 105-111.
- Rand, J. E. Behaviors observed during S- in a simple discrimination learning task. Journal of the Experimental Analysis of Behavior, 1977, 27, 103-117.
- Saslow, C. A. Operant control of response latency in monkeys: evidence for a central explanation. Journal of the Experimental Analysis of Behavior, 1968, 11, 89-98.

- Saslow, C. A. Behavioral definition of minimal reaction time in monkeys. Journal of the Experimental Analysis of Behavior, 1972, 18, 87-106.
- Schwartz, B., & Gamzu, E. Pavlovian control of operant behavior. In W. K. Honig & J. R. Staddon (Eds.), Handbook of operant behavior. Englewood Cliffs: Prentice-Hall, 1977.
- Schwartz, B., & Williams, D. R. Discrete-trials spaced responding in the pigeon: the dependence of efficient performance on the availability of a stimulus collateral pecking. Journal of the Experimental Analysis of Behavior, 1971, 16, 155-166.
- Schuster, C. Response latencies as a measure of the interaction of components on a multiple fixed-ratio schedule. Journal of the Experimental Analysis of Behavior, 1959, 2, 259.
- Skinner, B. F. Differential reinforcement with respect to time. The American Psychologist, 1946, 1, 274-275.
- Skinner, B. F. Cumulative record (2nd ed.). New York: Appleton-Century-Crofts, 1961.
- Snapper, A. G., & Inglis, G. B. SUPERSKED. Kalamazoo, Michigan: The SKED Users Group, 1980.
- Snapper, A. G., Ramsay, D. A., & Schoenfeld, W. N. Disruption of temporal discrimination under response-independent shock. Journal of the Experimental Analysis of Behavior, 1969, 12, 423-430.
- Staddon, J. E. R. Schedule-induced behavior. In W. K. Honig & J. R. Staddon (Eds.), Handbook of operant behavior. Englewood Cliffs: Prentice-Hall, 1977.
- Staddon, J. E. R., & Simmelhag, V. L. The "superstition" experiment: a reexamination of its implications for the principles of adaptive behavior. Psychological Review, 1971, 78, 3-43.
- Stebbins, W. C. Response latency as a function of amount of reinforcement. Journal of the Experimental Analysis of Behavior, 1962, 5, 305-307.
- Stebbins, W. C. Animal psychophysics. New York: Appleton-Century-Crofts, 1970.
- Stebbins, W. C., & Lanson, R. N. A technique for measuring the latency of a discriminative operant. Journal of the Experimental Analysis of Behavior, 1961, 4, 149-155.

- Stebbins, W. C., & Lanson, R. N. Response latency as a function of reinforcement schedule. Journal of the Experimental Analysis of Behavior, 1962, 5, 299-304.
- Stebbins, W. E., Mead, P. B., & Martin, J. M. The relation of amount of reinforcement to performance under a fixed-interval schedule. Journal of the Experimental Analysis of Behavior, 1959, 2, 351-355.
- Stebbins, W. C., & Miller, J. M. Reaction time as a function of stimulus intensity for the monkey. Journal of the Experimental Analysis of Behavior, 1964, 7, 309-312.
- Stebbins, W. C., & Reynolds, R. W. Note on changes in response latency following discrimination training in the monkey. Journal of the Experimental Analysis of Behavior, 1964, 7, 229-231.
- Stein, N., Hoffman, H. S., & Stitt, C. Collateral behavior of the pigeon during conditioned suppression of key pecking. Journal of the Experimental Analysis of Behavior, 1971, 15, 83-93.
- Ten Eyck, R. L., Jr. Effects of rate of reinforcement-time upon concurrent operant performance. Journal of the Experimental Analysis of Behavior, 1970, 14, 269-274.
- Terman, M., & Terman, J. S. Discrimination of brightness differences by rats with food or brain stimulation reinforcement. Journal of the Experimental Analysis of Behavior, 1968, 11, 29-37.
- Terman, M., & Terman, J. S. Latency differentiation of hits and false alarms in operant-psychophysical test. Journal of the Experimental Analysis of Behavior, 1973, 20, 439-445.
- Terrace, H. S. Discrimination learning with and without "errors". Journal of the Experimental Analysis of Behavior, 1963, 6, 1-27.