

UC Berkeley

Research Reports

Title

Restructuring The Automobile/highway System For Lean Vehicles: The Scaled Precedence Activity Network (SPAN) Approach

Permalink

<https://escholarship.org/uc/item/8qr921tc>

Authors

Pitstick, Mark E.
Garrison, William L.

Publication Date

1991

Program on Advanced Technology for the Highway
INSTITUTE OF TRANSPORTATION STUDIES
UNIVERSITY OF CALIFORNIA AT BERKELEY

Restructuring the Automobile/Highway System for Lean Vehicles: The Scaled Precedence Activity Network (SPAN) Approach

**Mark E. Pitstick
William L. Garrison**

**PATH Research Report
UCB-ITS-PRR-91-7**

This work was performed as part of the Program on Advanced Technology for the Highway (PATH) of the University of California, in cooperation with the State of California, Business and Transportation Agency, Department of Transportation, and the United States Department of Transportation, Federal Highway Administration.

The contents of this report reflect the views of the authors who are responsible for the facts and the accuracy of the data presented herein. The contents do not necessarily reflect the official views or policies of the State of California. This report does not constitute a standard, specification, or regulation.

April 1991

ISSN 1055- 1425

This paper has been mechanically scanned. Some errors may have been inadvertently introduced.

ABSTRACT

This research investigates the introduction of parking and road facilities for lean vehicles: small, one or two passenger vehicles that consume less energy and produce less pollution and congestion compared to present vehicles. The problem of transition from the existing automobile/highway system to an alternative system is addressed by identifying transition pathways.

A graphical technique is developed and used. It combines engineering benefit/cost analysis and precedence diagrams from project management. The approach defines and evaluates potential adjustments to the existing system and relationships between the adjustments. Each modification concept, adjustment, or technology is broken into development, implementation, and market growth activities which are represented on activity networks along with activities for other related technologies. The resulting activity networks can be used as tools to plan and evaluate transition pathways leading to new system designs.

A market range is calculated for each technology, based on expected benefits and costs, showing when the technology should be deployed and when it should be replaced. Since each activity has associated time, cost, and resource estimates for completion, scaled activity networks can also be drawn. The most useful diagrams are two-dimensional scaled precedence activity networks (SPAN) with time on the horizontal axis and market level on the vertical axis. SPAN diagrams show the market range for each technology and how soon each technology can be deployed. A plot of the expected market level versus time can be superimposed on SPAN diagrams to compare with the availability and range of the various technologies.

Various adjustments to existing parking and road facilities are identified, classified, and evaluated using the activity network approach. The concepts range from low cost modifications appropriate for introduction of lean vehicles into the market, to more expensive modifications suitable for larger numbers of such vehicles. Logical strategies for introduction, which span the expected market range by using a combination of several concepts, are identified from the SPAN diagrams. These deployment strategies, selected by matching the level of deployment of technologies with the market level, provide a means of accommodating and encouraging the use and adoption of lean vehicles without large initial investment.

PREFACE

This report stems from work that began in late 1989: work investigating the ways small vehicles might be introduced for use and accommodated on the existing highway system. The work was triggered by the General Motors Corporation's interest in a small vehicle it had developed, called the Lean Machine, and the consumer interest shown when the vehicle was on display. There was parallel interest by the Advanced Technology Division of the California Department of Transportation (Caltrans), because a vehicle of this class might hold promise for reducing congestion, air pollution, and energy consumption.

One thing was already apparent when the work began. Today's system of automobiles, highways, and their uses has grown over decades. The technology of each component is well honed and each component fits the others: vehicles fit roads and uses, roads fit vehicles and uses, etc. By custom and standards and because of existing investment, departures from the norm or novelties are rejected. For instance, small vehicles have been proposed and marketed from time to time, but have not been well accepted by consumers. The vehicles did not fit roads and uses.

Thus, it was clear that work should be scoped to system changes. Although we continue to take advantage of the opportunity provided by the Lean Machine, our concern now extends to lean vehicles as a class, where lean vehicles mean vehicles closely tailored to their functions and efficient in the use of road space and energy and with reduced environmental impacts. Specialization as a source of efficiency and improved product performance through specialization are key concepts, and we think of vehicles specialized to functions: commuting, neighborhood travel, freight distribution, etc.

Extending from vehicles and their applications in the system, road facilities are of concern, for without roads to accommodate specialized vehicles, such vehicles might have little future. Safety goals, mobility, and efficiency depend on roads to suit vehicles. The building of a new system of roads is pretty much unthinkable, so the question becomes

how roads might be redesigned to accommodate and even accelerate system change. Certainly vehicles similar to today's will remain, and, if they find market niches, new types of vehicles and uses may evolve over a period of time. So the question is posed, "How might the road part of the system transition to new designs suited to lean vehicles be accomplished without adverse impacts on old and new users?".

This report contains some findings on the transition topic. It emphasizes the development of a design methodology tailored to the problem.

The work reported here is proceeding in parallel with complementary community-based studies supported jointly by General Motors and Caltrans. Work proprietary to General Motors is dealing with market and vehicle design topics, and Caltrans supported work treats the identification of possible needs for road modifications. The breadth of the investigation requires that many other actors be involved: possible vehicle purchasers and users, community planners, vehicle safety regulators, local transportation agencies, etc. Such broad involvement will increase as the work goes forward.

TABLE OF CONTENTS

	Page
ABSTRACT	i
PREFACE	ii
TABLE OF CONTENTS	iv
LIST OF TABLES	viii
LIST OF FIGURES	ix
1. INTRODUCTION AND MOTIVATION	1
1.1. Introduction
1.1.1. The LeanVehicle Idea	1
1.1.2. The Design Approach	5
1.2. Motivation..	6
1.2.1. Alternative Designs versus Improved Existing Designs..	7
1.2.2. How to Design versus What to Design..	7
1.2.3. Success and Failure in Transportation System Designs	8
1.3. Design Evolution and Market Growth.....	10
1.3.1. Design and Market States..	10
1.3.2. Relationship between Design and Market	11
1.3.3. Roles of Actors..	13
1.3.4. Context versus Specific	14
1.4. Applicability to Other Transportation Systems	15
2. DESIGN METHODOLOGY REVIEW..	17
2.1. Search for an Improved Design Methodology	17
2.1.1. Engineering/System Design Methods	17
2.1.2. Second Generation Design Methods..	18
2.1.3. Ideas from Economics..	20
2.1.4. Ideas from Project Management.....	22

2.2. Review of Activity Network Techniques.....	23
2.2.1. Arrow Diagrams	23
2.2.2. Precedence Diagrams.....I....	24
2.2.3. Time-Scaled Diagrams	27
2.2.4. Resource Constrained Scheduling and Time-Cost Tradeoff.. . . .	27
2.2.5. Statistical Approaches	29
2.2.6. Probabilistic Branching and Looping.....	30
2.3. Application to Transportation System Design I.....	32
3. ACTIVITY NETWORK APPROACH	34
3.1. Activities and Dependencies	34
3.2. Approach Outline	37
3.2.1. Market Range Calculations	39
3.2.2. First Application Limits	45
3.3. Scaled Precedence Activity Network (SPAN) Diagrams.....	46
3.3.1. Time-Scaled Diagrams	46
3.3.2. Time and Market Scaled Diagrams.....	49
3.3.3. Combinational Strategies	52
3.3.4. Using SPAN Diagrams I.....	56
3.4. Comparison with Current Design Approach.....	57
3.5. Method Distinction.....	62
3.6. Applicability to Other Transportation Systems I.....	63
4. CASE STUDY: LEAN VEHICLE PARKING FACILITIES	65
4.1. Parking Modification Concepts	67
4.1.1. Parking Lots.....	68
4.1.2. Parking Garages	71
4.1.3. Street Parking	72
4.2. Activity Networks	75

4.3. Market Range Calculations	79
4.4. SPAN Diagrams..84
5. CASE STUDY: LEAN VEHICLE ROAD FACILITIES	99
5.1. Road Modification Concepts..99
5.1.1. Situations	100
5.1.2. Solutions	101
5.1.3. Highway Links/Bottlenecks	103
5.1.4. Arterial Links/Bottlenecks	108
5.1.5. Arterial Intersections..	108
5.1.6. Highway Interchanges110
5.1.7. Special Structures	111
5.2. Activity Networks	111
5.3. Market Range Calculations	120
5.3.1. Benefits	120
5.3.2. Costs..132
5.3.3. Market Ranges	135
5.4. SPAN Diagrams	136
6. SUMMARY AND CONCLUSIONS	144
6.1. Summary	144
6.2. Conclusions	145
6.2.1. Results	145
6.2.2. Limitations	147
6.2.3. Relation to Highway Funding Programs.....	147
6.3. Further Research	148
6.3.1. Extensions	148
6.3.2. Additions	149

APPENDIX A: REVIEW OF MINICARS AND RELATED STUDIES.	152
Minicar Vehicle Development	152
Previous Minicar System Studies	154
APPENDIX B: THE EFFECT OF LEAN VEHICLES ON CAPACITY..	157
Geometric Effect	157
Review of Prior Research..	158
Lean Vehicle Calculations	160
Side-by-Side Driving	162
Discussion	165
APPENDIX C: SAMPLE CALCULATIONS	167
Parking Modifications for Lean Vehicles	167
Road Modifications for Lean Vehicles	169
BIBLIOGRAPHY	172

LIST OF TABLES

Table	Page
3.1 Technology Activity Parameters	43
4.1 Number of Spaces Added and Removed for Parking Modifications82
4.2 Estimated Value of an Additional Parking Space..83
4.3 Unit Cost Estimates for Parking Modifications	83
4.4 Unit Cost Estimate for Parking Development83
4.5 Activity Time and Cost Parameters for Parking Modifications85
4.6 Market Ranges for Parking Modifications - Strategy 0.....	.86
4.7 Market Ranges for Parking Modifications - Strategy 1	93
5.1 Classification of Special Lanes	100
5.2 Highway Parameters for Benefit Calculations..128
5.3 Fuel Parameters for Benefit Calculations129
5.4 Unit Cost Estimate for Special Lane Development..132
5.5 Unit Cost Estimates for Road Modifications	133
5.6 Activity Time and Cost Parameters for Special Lanes	134
5.7 Market Ranges for Special Lanes - Strategy 0.....	135
5.8 Market Ranges for Special Lanes - Other Strategies	140
C-1 Implementation Costs for the Dead Space Concept	167
c-2 Implementation and Market Growth Costs for the One-to-one Concept169

LIST OF FIGURES

Figure	Page
1.1 General Motors Lean Machine.....	2
2.1 Vehicle supply and demand with a changing design.....	21
2.2 Arrow diagram (activity-on-arrow).....	25
2.3 Precedence diagram (activity-on-node).25
2.4 Time-scaled arrow diagram.....	28
2.5 Time-scaled precedence diagram.....	28
2.6 Arrow diagram with probabilistic branching and looping.....	31
2.7 Precedence diagram with probabilistic branching and looping.31
3.1 Major activities for each new technology.	36
3.2 Expanded view of the major activities.....	36
3.3 Unscaled precedence activity network for four related technologies.....	3 7
3.4 Market range calculations.41
3.5 Total benefits and costs versus market level.....	.41
3.6 Lower and upper market range limits.....	44
3.7 Bar chart (Gantt chart) for four related technologies.....	47
3.8 Time-scaled precedence activity network with activity dependencies.....	4 7
3.9 S-shaped logistic curve for market growth.....	48
3.10 Phased design for an airport.....	49
3.11 SPAN diagram for four related technologies (strategy zero).51
3.12 SPAN diagram without development activities (strategy zero).51
3.13 SPAN diagram for strategy one.....	54
3.14 SPAN diagram without development activities for strategy one.54
3.15 First application limit compared to upper limits ($j > 0$).....	55
3.16 SPAN diagram with “maximum” market growth curve.....	.57
3.17 Stretched SPAN diagram for strategy one.....	58

3.18	Bar chart (Gantt chart) for intersection control.	59
3.19	SPAN diagram for intersection control.	61
4.1	Two-in-one concept for parking lots and garages	69
4.2	Restripe concept for parking lots and garages	69
4.3	Parking lot with section restriped for lean vehicles	70
4.4	Two-in-one and restripe concepts for parallel street parking.	73
4.5	Two-in-one and restripe concepts for perpendicular street parking	74
4.6	Parking lot and garage activity network.	76
4.7	Street parking activity network.....	78
4.8	Parking lot SPAN diagram - Strategy 0.....	88
4.9	Parking garage SPAN diagram - Strategy 0.....	89
4.10	Parallel street parking SPAN diagram - Strategy 0.	90
4.11	Perpendicular street parking SPAN diagram - Strategy 0.....	91
4.12	Parking lot SPAN diagram - Strategy 1	94
4.13	Parking garage SPAN diagram - Strategy 1.	96
4.14	Parallel street parking SPAN diagram - Strategy 1.	97
4.15	Perpendicular street parking SPAN diagram - Strategy 1	98
5.1	Shared and exclusive lean vehicle lanes.....	102
5.2	Elevated lean vehicle lanes in highway median.....	104
5.3	Outrigger lean vehicle lanes on bridge or viaduct.....	104
5.4	Stacked lean vehicle lanes in a rectangular tunnel.....	105
5.5	Stacked and shoulder lean vehicle lanes in a circular tunnel.	105
5.6	Lean vehicle lanes within the structure of a large bridge.....	106
5.7	Intersection with shared lanes and reversible flyover for lean vehicles.....	110
5.8	Diamond interchange with shoulder lane for lean vehicles.....	112
5.9	Diamond interchange with ramp flyover for lean vehicles.....	112
5.10	Highway activity network.	113

5.11	Arterial activity network.....	115
5.12	Intersection activity network.....	117
5.13	Interchange activity network.....	118
5.14	Structures activity network.....	119
5.15	Cumulative curves for a quadratic arrival rate.....	122
5.16	Benefits of a one-to-one shared lane.....	130
5.17	Benefits of a two-to-one shared lane.....	130
5.18	Benefits of one exclusive lane.....	131
5.19	Benefits of two exclusive lanes.131
5.20	Highway SPAN diagram (shared lane technologies) - Strategy 0.137
5.21	Highway SPAN diagram (exclusive lane technologies) - Strategy 0.138
5.22	Highway SPAN diagram - Strategy 1	141
5.23	Highway SPAN diagram - Strategy 2.....	142
5.24	Highway SPAN diagram - Strategy 3.....	143
B-1	Multilane highway capacity (per lane) vs. lean vehicle fraction.164

1. INTRODUCTION AND MOTIVATION

1.1. Introduction

This research investigates the restructuring of the existing automobile/highway system for lean vehicles; small vehicles which could be used for commuting or other purposes. The idea was inspired by narrow, single passenger vehicles designed by General Motors called “Lean Machines” (Figure 1.1). The goal is to modify the existing road and parking facilities to accommodate and encourage the use of lean vehicles similar to the Lean Machine (but not limited to such). The emphasis in this study is on facility design since vehicle suppliers will take care of vehicle design. Instead of the usual question of “what to design,” this research attempts to answer the question of “how to design.” How do we get from the current vehicle/highway situation to some improved situation that involves lean vehicles? What is the path? What needs to be done now and what can wait until later? We seek a gradual, cost effective transition from today’s situation to situations that would emerge if consumers seek to purchase and use lean vehicles.

1.1.1. The Lean Vehicle Idea

Although the words may seem new, the idea of lean vehicles is not. When compared to present vehicles, lean vehicles would consume less energy, produce less pollution and congestion, and cost less to own and operate. National policy and vehicle producers and users have sought such vehicle improvements in the past and seek them now. But experience during recent decades says that small, lightweight motorized passenger vehicles are not likely to be successful in markets. Many designs have been proposed, and there have been a dozen or so attempts to produce and market such vehicles (Appendix A reviews experiences and studies of small vehicles). The problem is that the present overall structure of the highway system accommodates present vehicle types but discourages novelties. In order for opportunities from new classes of vehicles to emerge there must be system adjustments which accommodate the new vehicles.

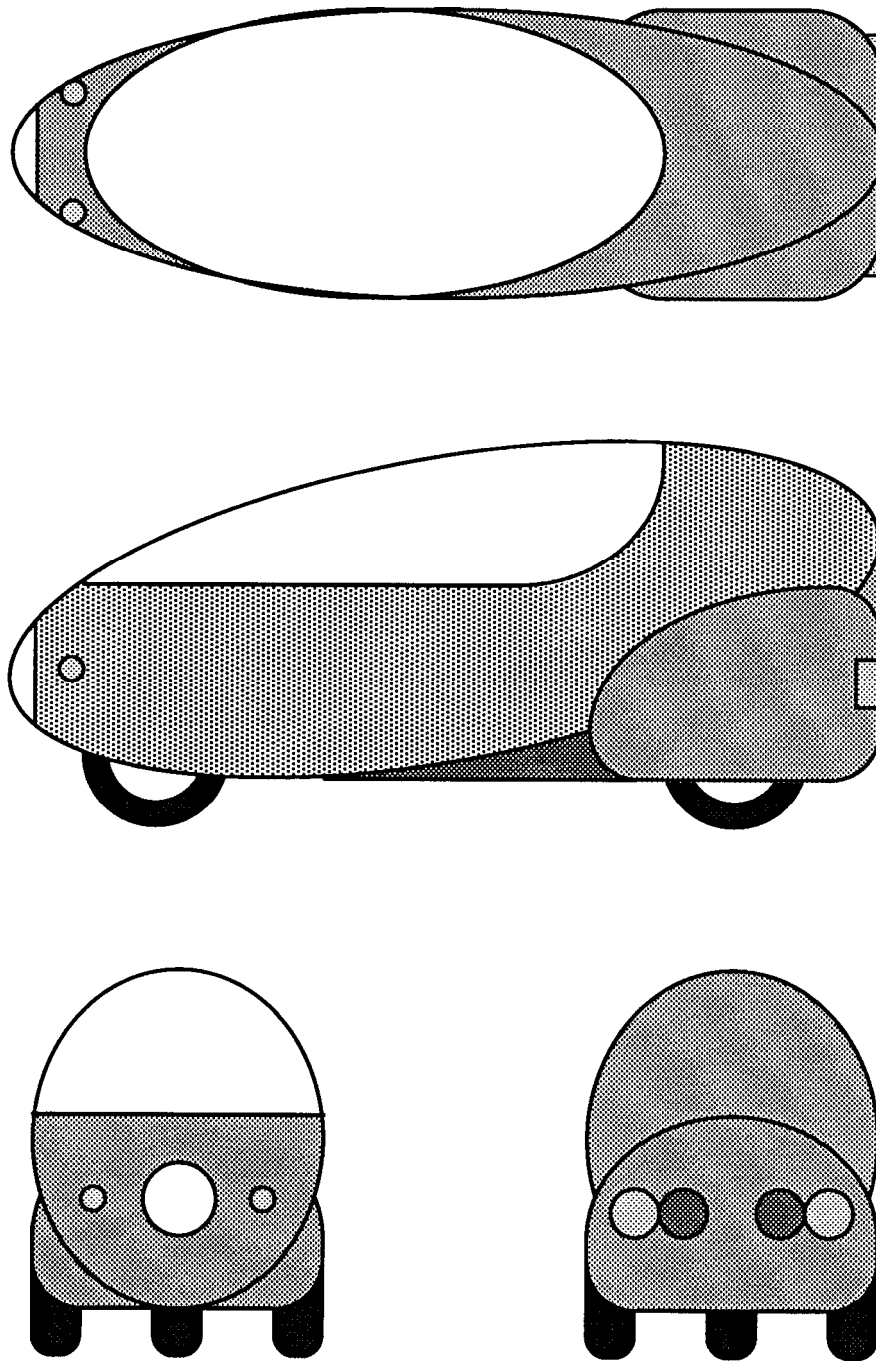

Figure 1.1. General Motors Lean Machine.

The potential benefits to be provided by lean vehicles assume that system changes will accompany introduction of the vehicles. Lave [1980] suggests a radical restructuring of the system for commuter vehicles, but, as stated, the modifications outlined in this study are intended to be done incrementally. Results are presented from analyses of the ways parking and road facilities might be adjusted for lean vehicles. Existing facilities do not necessarily have to be modified to accommodate lean vehicles, but modification could result in substantial cost reductions for facility providers, as well as vehicle users, and these would encourage ownership and use of lean vehicles.

Garrison and Pitstick [1990a,1990b] discuss the gradual transition of vehicle fleets from today's automobiles to lean vehicles (which are also automobiles in a *generic sense*). Topics identified for analysis include benefits and costs when considering both the vehicles and the facilities on which they might operate. Would facility adjustments be easy or difficult? What sequence of adjustments would be in order, and how should adjustments be timed to the increasing population of lean vehicles? What are the relations between benefits and costs, and who would capture benefits and incur costs? A key question is whether early users of lean vehicles, and highway agencies where lean vehicles are used, would have to bear a disproportionate share of transition costs, thus limiting or blocking adoption of lean vehicles. That key question is addressed by this study. The modifications outlined in this study provide a means of accommodating and encouraging the use and adoption of lean vehicles without large system transition costs.

The vehicle used as an example in this research, the General Motors Lean Machine, is about 9 feet long and 3 feet wide. Now existing only in prototype form, a production vehicle is suggested that might accommodate 1+ persons, weigh under 500 pounds, accelerate to 60 mph in under 8 seconds, cost \$5,000 to \$10,000, and achieve 100-150 mpg depending on engine and accessories. The Lean Machine has three wheels and achieves cornering stability by leaning the body and the single front wheel (a brief history of the Lean Machine development and driving characteristics is given by Egan [1983]).

With a small footprint and high performance, significant numbers of lean vehicles similar to the Lean Machine might relieve traffic and parking congestion. Other lean vehicle attributes are achieved because of light vehicle weight and small engines.

One of the largest potential benefits from lean vehicles is reduced congestion and travel delay provided by the higher capacity of roadways carrying lean vehicles. Estimates of the nature and magnitude of the capacity increase are discussed in Appendix B and are also summarized here. The capacity increase provided by lean vehicles would be due to a combination of the geometric effect of shorter vehicles and the possibility of side-by-side driving on present-day road lanes. The capacity increase for a single line of Lean Machines is estimated at 5% for free flow on a two-lane undivided highway, 13% for free flow on a multilane divided highway, and 18% for saturation flow at a single signalized intersection. These conservative estimates of roadway capacity increases are based only on the geometric effects of shorter vehicles and do not include the possibility of vehicles driving side-by-side in standard width lanes, which should be possible given the narrow width of Lean Machines. The potential for travel time savings, along with the expected reduction in fuel consumption and pollution generation, provide motivations for the modification of existing road facilities.

We don't know what a system for lean vehicles will look like. The actual design would evolve over time due to actions and interactions among facility and vehicle suppliers, users, and intermediaries, none of which can be accurately predicted. Projections made by facility suppliers about technologies which could be included in the design will also change over time as new knowledge and experience are acquired. This research simply makes a first cut at the design process which facility suppliers will carry on continuously. This research attempts to define what must be done now and what can be done later. It identifies what types of calculations need to be performed and what information is required to perform them. The purpose of the study is not to design a complete transportation system for lean vehicles. Indeed, because of uncertainties about how the system might change, it

is neither desirable to design the complete system from the outset, nor would it be possible since there are numerous current and emerging technological opportunities for vehicle and roadway designs.

1.1.2. The Design Approach

Any design approach should take advantage of lessons learned and then modify lessons as needed. The **first** step is to look at transportation system design from a historical perspective. How were previous and existing systems designed? Were (are) those designs successful or not? The next step is to search for improved design methods which better match the lessons learned from the historical perspective. How does the design process work? What can be done to improve the process? The ultimate goal is to combine existing, modified, and new design methods into a new package which improves the process of designing transportation systems. The final step is to apply the improved design methods to the lean vehicle situation. Thus, the approach might be summarized as follows: look back, look around, and look ahead.

A brief discussion of the types of transportation design problems may aid in presenting the thrust of this research. Consider, for example, the treatment of control at highway intersections as traffic levels grow. The control proceeds as follows: no control, yield signs, stop signs, simple traffic signals, multiphase traffic signals, and finally, **grade-separated** intersections. Through knowledge gained over a long period of time, facility designers have techniques that can be applied with confidence to this “old technology” design problem.

Implementation of a system with “new” technologies introduces a different type of design problem. An example is the design of a high-speed rail system. In this case, the requirement of new routes and large, lumpy investments is very demanding. It dictates that the advances in technology (for facilities, equipment, and operation) be well known and

that there be a high level of confidence about the market situation, otherwise the investment is risky. With imperfect information, many such designs have failed in the past.

The new technology design problem presented by lean vehicles is the focus of this research. However, this research concentrates on a design strategy that is in part similar to that for the old technology design problem discussed above: the step-by-step evolution of the design as the demand increases. Concern is with the design process and development pathways. The approach is to speed introduction and transition, compared to evolutionary change, by identifying technologies and pathways with low transition costs. The design strategy also recognizes the evolution of non-facility technologies.

Because the problem as stated is novel, the discussion to follow must go to some length to position the problem and the approach. The first chapter presents the motivation for the design strategy and describes the context within which the strategy must operate. The second chapter reviews techniques from several fields which will be useful in such a strategy. The third chapter describes the design approach, and finally, the fourth and fifth chapters describe an application as it applies to the lean vehicle situation.

1.2. Motivation

The problems with the automobile/highway system are well known and well documented. In important ways, the existing system is mature because the technologies and their uses are well defined. The market is saturated. The system is approaching obsolescence because it was designed many years ago for previous goals and patterns of usage. It no longer fits the time or the place (the geographic pattern) in which it is used and today's ecological and energy situations. The logical and necessary course of action seems obvious; either new transportation systems must be designed or the existing automobile/highway system must be redesigned. These two courses of action are not mutually exclusive, because a new system may be thought of as emerging as an old system

is redesigned. That is the way today's systems were created, as recollection of the shift from the wagon-road system to today's system reminds us.

1.2.1. Alternative Designs versus Improved Existing Designs

There are currently two approaches in the field of transportation system design. One approach is to work towards optimizing or improving the efficiency of existing systems. This approach is usually applied to "old technology" design problems. The second approach, which is the focus of this research, is to work towards a set of alternative systems. Examples of alternative designs include lean vehicle roadways, truck highways, and automated highways. These are not radical departures from existing designs since they do not start with clean sheets of paper, but instead take advantage of existing designs and use them as points of departure. There are factors both pushing and pulling for more rapid change than would result from the "improve efficiency" path. Factors that are pushing include environmental concerns, energy consumption, and capacity shortages. Factors that are pulling include the desire for increased mobility by everyone involved in transportation, including individuals, shippers, businesses, and governments.

The goal of this research is to stimulate innovation beyond what would occur with the "improve efficiency" path. Alternative designs should allow us to increase supply and/or improve service; however, we must try to avoid "dead end" designs, which are those that offer no further improvement without a radical restructuring or change to a different design path. Interstate freeways represented a radical departure because they required new rights-of-way in most locations. In this respect they were not an incremental change from the previously existing traditional highways, which were "dead end" designs. (In other respects, interstate freeways built incrementally from the existing system.)

1.2.2. How to Design versus What to Design

When attempting to solve some of today's transportation problems it is natural to think of some future transportation systems which do not have the problems mentioned.

What will the next generation transportation systems look like? If some potential transportation systems can be identified (such as lean vehicle systems) that appear to be better than existing systems, then the question becomes, “How do we get from here to there?”. What steps need to be taken to arrive at some potential future state? Certainly no transportation system is going to be implemented completely in one step. This turns our focus to the design process itself in an attempt to determine the design path.

Actually, the design path does not have to be determined completely. Once the potential paths are outlined, the main decisions are what must be done now, and what can wait until later. The approach is to outline design steps, then concentrate on the first few steps. Those things that are put off until later might in fact never get done, due to changes in consumer preferences or the emergence of new information and technologies.

This research attempts to guide decisions about design for the next generation of transportation systems. Specifically, how would you design a system for lean vehicles, given that it does not exist today and will take time to evolve? Also, how will the new design coexist with current systems (at least initially), since a complete and separate system cannot be implemented immediately? Answers to these questions could be used to design transportation systems other than the lean vehicle system, such as automated highways, truck highways, and high-speed rail lines. The results obtained from this research might also be applicable to other designs, but this issue is not investigated here.

1.2.3. Success and Failure in Transportation System Designs

Concentrating on the process of design, we should take a look back at how previous and existing transportation systems were designed. What are the lessons to be learned, and how can these lessons be applied to the design of the next generation of transportation systems? In order to limit the length of this historical perspective, the lessons learned will only be briefly summarized.

A thorough review of the experiences of early transportation system designs, such as canals, roads, railroads, trolleys, mass transit, trans-atlantic shipping, highways, and commercial aviation, is presented by Vance [1986]. He concludes that these systems were successful because they fit both the time and the place in which they were used - the geographic pattern. These systems were not designed outright from the beginning, but instead the design evolved over many years in response to changing needs through a process of trial and error. In fact, most of the earliest examples of these designs were intended for some purpose that was quite different from their eventual use.

In contrast, more recent transportation designs, such as the Bay Area Rapid Transit (BART) system, the Supersonic Transport (SST), and the space shuttle, were designed using engineering/system design procedures. These procedures were “invented” at about the same time that these systems were being designed. Although these designs were not complete failures, they cannot be considered successful because they required large initial investments and failed to meet many of their design goals. These problems can be attributed in part to applying engineering/system design procedures to transportation systems that need to adapt to changing conditions, as will be discussed in more detail in the next chapter.

The lesson is that engineering/system design by itself does not work well for transportation systems and that in designing future systems we should incorporate an evolutionary process which allows continuous adaptation of the design to fit the time and the place. The next chapter describes a search for just such a design strategy. We want to identify transition pathways for changes that lead eventually to alternative designs that provide major (perhaps order of magnitude) reductions in cost or improvements in capacity or service. Successful new systems are a combination of building blocks: mostly existing but some new or nearly new. The real innovation is the way the building blocks are put together.

1.3. Design Evolution and Market Growth

In order to improve the design process, we must first understand the context within which the process operates. This section presents a qualitative model of the evolutionary design process and its relationship to market growth.

1.3.1. Design and Market States

A transportation system design is the result of the packaging of many different technologies. These include vehicle technologies, facility technologies, operation technologies, and control technologies. At any particular point in time, the system design consists of a certain set of technologies. The design evolves over time as different technologies are adopted into or discarded from this set due to market forces and other factors. There are also spatial and temporal distributions for the deployment of each technology. At any particular time, each technology is represented at a certain number of locations. The state of the design can be thought of as a snapshot in time across all technologies for a particular area, which can be either large or small or anywhere in between.

The market also has spatial and temporal distributions and the same comments regarding snapshots can be made about the state of the market. If we compare a design snapshot to a market snapshot taken at the same time for the same area, we should see that there are strong dependencies. The market will not grow beyond the potential created by the design due to equilibrium considerations.

Also, the design can not remain ahead of the market for long periods due to economic considerations. Facility suppliers do not have unlimited resources. Even when they have ample resources it is not economically prudent for them to deploy facilities far ahead of the market. This does happen sometimes, but it is the exception and not the rule. Any facility supplier who continues this practice over a long period is likely to exhaust the surplus of resources. Furthermore, no one has the knowledge to accurately predict how

the market will respond to the design, thus any facilities which are deployed prematurely could end up as wasted resources. Most frequently the facility suppliers have a shortage of resources, thus the state of the design never gets very far ahead of the state of the market.

While the market is growing over the long term, it is unlikely that the market will grow beyond the potential created by a design, even temporarily. This should certainly be true for the overall market and design because there would be no incentive for a new customer to join the market if the design was not capable of providing some benefit to the new customer. On the other hand, it would be quite possible for a local market to exceed its potential, either temporarily or over a longer term, if the local design was somehow deficient (this could be considered as a “design opportunity”). Highway congestion in some markets illustrates this situation - the designs lag behind the market. Thus, in a growing market the state of the market will follow the state of the design, at least on an overall basis. Delaying the design in a growing system could delay the market growth. These observations have implications for the facility designers/suppliers. (Of course, in a declining market the state of the market could either lead or follow the state of the design, but declining market issues are not treated in this study.)

1.3.2. Relationship between Design and Market

The objective is to understand the relationship between the design and the market and to use this understanding to improve the process of designing new systems. There are two possible courses of action. We could attempt to improve the situation by manipulating the market or we could attempt to improve the situation by manipulating the design.

There are several possible ways of attempting to manipulate the overall market, such as enacting steering legislation, regulations, and tax structures. However, it is difficult to predict the results of such actions and in many cases they simply do not work because the market is able to work its way around such obstacles or obstructions. This is probably due to the fact that the market follows the design on a global basis, as already

mentioned. Thus, we should not be too concerned with attempting to manipulate the global market. On the other hand, there are special cases of the above actions, such as relaxing zoning regulations, which could be used to manipulate the design by favoring or allowing the use of certain new technologies. Similarly, there are ways of indirectly manipulating the market with, for example, subsidies, discounts, and incentives, which could be used to encourage or enable the use of particular technologies. This research considers such market manipulations, but only if they can be incorporated into the design process.

Each time the state of the design changes there is a temporary disequilibrium of the market. The design change will be due to the addition (or removal) of a technology at a certain location (either a new or an existing technology). This location will temporarily experience an increased (or decreased) market potential. Eventually the market will respond by some combination of redistribution and/or growth, until a new equilibrium is reached.

Thus, there is a dynamic feedback loop which relates the state of the market to the state of the design. Improving the state of the design creates an opportunity for market growth. If the market does grow, this provides resources either for deploying more existing technologies or for developing new technologies. The ultimate result is an evolving design and a market which grows over time. If there were unlimited resources (including money, manpower, and equipment) which could be applied to improving the state of the design, the market would grow at some inherent rate which is a result of the many underlying interactions which influence the design process. Historically, overall markets have grown in a manner which approximates a logistic (S-shaped) curve, but there have been deviations from the curve (see Garrison [1989] and Grubler [1989]). One of the reasons for deviation is the fact that resources are limited, thus the design grows more slowly, perhaps slow enough to limit the growth of the market.

Another factor which influences the rate of market growth and design evolution is the learning curve. The design evolution and market growth will be comparatively rapid

for subsequent applications of a particular system (in another country for instance) compared to the initial application because much of the learning about the various technologies and the design as a whole will have already taken place.

The next step could be to express the preceding paragraphs in mathematical form, which would include differential and integral equations, spatial and temporal distributions, local and global variables, and long and short term trends. However interesting and useful such an exercise might be, it is not the focus of this research to establish that mathematical representation. A mental picture of the relationship between design and market is enough to provide a framework within which the process of designing transportation systems must operate.

1.3.3. Roles of Actors

The framework within which the design process works includes not only the relationship between designs and markets, but also the relationships between the various actors which influence design processes. Each of these actors makes decisions regarding individual technologies based on their own benefit/cost calculations or perceptions. Actors' decisions determine the success or failure of individual technologies and thus shape the overall design. If the benefits of a particular technology go to one category of actors and the costs are borne by a second category of actors which makes decisions crucial to the success of that technology, then that technology is not likely to be implemented without some mechanism for the transfer of benefits or costs between those groups.

The most important actors involved in the transportation design situation can be classified into the following four categories:

1. Vehicle Suppliers.
2. Facility Suppliers.
- 3.** Users.
4. Intermediaries.

The role of vehicle suppliers is obvious, they produce the vehicles required by the transportation system. Facility suppliers are those that design, implement, and (in part) operate the systems. This includes local, regional, state, and federal transportation departments and agencies, as well as safety and standards groups. Users participate in the systems as operators. They include not only individuals, but also groups. Intermediaries are those whose actions influence the decisions made by the other three groups. These actions can involve things like transfer payments, subsidies, discounts, and regulations (or relaxing of regulations). A particular group or individual can play the roles of more than one category of actors depending on the situation; however, these roles are clearly distinguishable and separate. The different roles a particular group can play are best illustrated by example. The following roles are from the case of a system design for lean vehicles:

Roles of a Firm (Company)

1. Firm as User - uses lean vehicles in its motor pool.
2. Firm as Facility Supplier - builds lean vehicle parking garage.
3. Firm as Intermediary - buys lean vehicles for its executives.

Roles of a Government Agency

1. Government as User - uses lean vehicles for law enforcement officers.
2. Government as Facility Supplier - builds lean vehicle roadways.
3. Government as Intermediary - lowers registration fee for lean vehicles.

1.3.4. Context versus Specific

The preceding material regarding the relationship between design and market and the roles of various actors provides the context within which the process of design operates, but it is not the focus of this research. The focus of this research is to improve the process of design by concentrating on the role which is most directly related to design and provides the most potential improvement, specifically the role of the facility

designers/suppliers. Of course the roles of the other actors are important, but their decisions do not shape the design as directly.

Users decide whether or not a particular technology is accepted and thus incorporated into the design. Facility suppliers will have to assume that the necessary vehicles will be available in order to design the facilities. The vehicle suppliers must decide whether or not to produce the required vehicles, but that decision depends on their expectations or forecasts of what users and facility suppliers will do. That problem is not insignificant; vehicle suppliers spend millions of dollars to explore the markets for new vehicles and then develop the vehicles. Innovative vehicles will not be developed if a clear path to market cannot be identified. Other actions performed by vehicle suppliers, such as production processes and market preference studies, are well understood and models already exist. Actions by intermediate actors will be considered as part of the facility design process since they will either favor or discourage particular technologies and thus influence the range of conditions under which each technology is part of the design.

Thus, a model for the design process will be most useful to facility suppliers, but such a model will also be useful to vehicle suppliers and government planners. In order to improve their forecasts of how the design will evolve and the market will grow, vehicle suppliers must either model the design process themselves or look at the work done by the facility designers. Government planners can use such a model to help them decide what actions to take as intermediaries to influence the evolution of the design and hence the market growth.

1.4. Applicability to Other Transportation Systems

The design strategy developed for lean vehicles should be useful for a variety of other transportation systems which require a phased design approach, especially those with private vehicles using public ways and/or ports. The vehicles would not have to be owned by individuals, but could also be owned by **firms**. Two examples which fit this pattern are

intelligent vehicle/highway systems (**IVHS**), and truck highways. Design of port facilities for an innovative method of shipping also fits this pattern.

Public transportation requires slightly different treatment because of the **multiple**-passenger nature of trips, but some of these systems still have individual vehicles (publicly or privately owned) using public ways and/or ports, in which case the phased design approach would be useful. Two examples are the design of a system of bus guideways and high occupancy vehicle (**HOV**) lanes, and the design of a system of facilities for short and vertical take-off and landing (**STOL** and **VTOL**) aircraft. The design of a high-speed passenger (or freight) rail system could also benefit from the phased design approach if we are considering upgrading a given corridor or corridors.

New transportation systems consist of mostly existing technologies combined with a few new technologies. The system innovation is the way those technologies are put together. We are looking for a design process which matches this description of how successful transportation systems are formed. That description also guides us in the packaging of a new design approach; we are looking for a new arrangement of mostly existing techniques with, perhaps, a few new techniques. With this focusing of the intended use of a method which improves the design process, attention can now be shifted from the context in which the method operates to the specific details of the method which are outlined in the next two chapters.

2. DESIGN METHODOLOGY REVIEW

2.1. Search for an Improved Design Methodology

The lean vehicle system design problem now leads us to search for an improved design methodology which allows us to make a transition to an alternative system without the “all-or-nothing” approach. The goal is to speed introduction and transition, compared to evolutionary change, by identifying technologies and pathways with low transition costs.

We seek to borrow design ideas from several fields and combine them into a unique package which will be useful for improving the design process. Those fields are engineering/system design, environmental/architectural design, economics, and project management. This chapter will not be a thorough review of these fields; rather, it will only present those ideas that are pertinent to the problem at hand.

2.1.1. Engineering/System Design Methods

An outline of the engineering/system design approach usually includes the following steps in a cyclical procedure [Alger and Hays, 1964, p. 10]:

1. Recognize and identify the problem.
2. Specify inputs and outputs.
3. Propose alternative solutions.
4. Evaluate alternative solutions.
5. Decide on a solution.
6. Implement the solution.

The words used by other authors to describe these steps are slightly different, but the general ideas regarding the required steps are basically the same.

As discussed in Chapter 1, the engineering/system design approach has not been very successful in the transportation field. Engineering/system design is basically an outgrowth of product design, thus the approach works well for systems that are products,

but not for transportation systems which are “artificial systems,” as Simon calls them [Simon, 1981, p. ix]. Systems that are products have a fixed form and are replaced entirely when they become obsolete. Artificial systems are those that adapt or are adapted to their environment, in reference to goals or purposes which shape their form and behavior. Simon also suggests designing for future flexibility in order to “...keep open the options for the future or perhaps to broaden them a bit by creating new variety and new niches” [Simon, 1981, pp. 186-191].

From the view of transportation design, the basic problem with engineering/system design is that it attempts to solve a static definition of a problem which is actually dynamic. Based on transportation design successes, perhaps design should be looked at as an evolutionary process which results from individual components and technologies being tested by the market. Salzer [1961] recognized some of the problems with traditional engineering/system design and proposed an evolutionary design approach for complex systems. Unfortunately, the outline for his approach was much like the system design approach except that the design was implemented in phases and the design could change over time. Similarly, Fearnside [1987] recognized the need for concentrating on the design path, and he recommends a dynamic programming approach for optimal decision making. However, it is unlikely that an optimal design path can be determined for the types of systems we are trying to design, because the choices and calculations would change as time progresses.

2.1.2. Second Generation Design Methods

There are several ideas from the environmental/architectural design field which should help us avoid some of the problems of engineering/system design described above. Early design methods used in engineering/system design were systematic and used formal techniques from product design, systems analysis, operations research, and creativity studies. Rittel and Webber [1973] concluded that such “first generation” design methods

were inappropriate for “wicked problems” like ill-defined planning and design problems in which the problem and solution are interdependent. Instead, they proposed a “second generation” of design methods involving “participation” and “argumentation” since expertise and relevant knowledge are distributed among a wide range of participants.

Jones [1984, pp. 139-158] suggests focusing on the design “process” instead of the design “product.” He suggests a divergence stage, followed by a transformation stage, and finally a convergence stage. The divergence stage involves variety generation by exploring the situation - brainstorming. The transformation stage involves perception of the problem/solution interdependency. The convergence phase involves variety reduction through evaluation of alternatives and selection of a solution. Perhaps the problem with first generation design methods is that they try too hard to force convergence.

A thorough discussion of the application of the evolution analogy to design, especially architectural design, is presented by **Steadman** [1979]. The evolutionary process is described as a series of spontaneous changes, coming from within the organism, which are then “tested” against the environment. Those changes which represent an improvement are preserved by natural selection [Steadman, 1979, pp. 75-82]. The evolution analogy is useful for design, but we should be able to get better results than if we simply let the system evolve, because we need not depend on random variation as in the natural world. In design we can change the system to provide the variations. We don’t want or need too many variations, but rather intelligent ones. (However, revolutionary ideas may not seem intelligent at the time, thus we might miss some of the best variations.)

Steadman warns that we must be careful to avoid “biological fallacies,” which result from taking the evolution analogy too far and too literally. If this happens the purpose of the individual designer fades away because the design is achieved entirely through “selection” of random variations [Steadman, 1979, p. 188]. In both evolution and design, trials are provided by variations and errors are detected and removed by selection. The difference is that in design, adaptation is guided by market selection instead of natural

selection. Rzevski [1981] concluded that very large systems should not be designed as monolithic structures but should be allowed to evolve as both designer and client (population) learn as the design progresses.

Unfortunately, some of the second generation design methods took the argumentation and participation too far. Broadbent [1981] points out architectural inadequacies of buildings designed by the participatory approach; “a result of the trendy politics of the 1960s.” He suggests a “third generation” of design methods which combine the best of the first and second generations techniques (that is probably what Rittel and Webber intended in the first place).

2.1.3. Ideas from Economics

We can also look at design from an economic perspective. Von Hayek [1945] tells us that knowledge of the particular circumstances of time and place are better commanded by individuals instead of a central authority. When knowledge is provided to individual decision makers in the form of prices, their plans will fit with the plans of others due to the interaction of supply and demand. Perhaps this concept can be extended to design, such that systems are designed by market selection, which is the result of decisions by many individuals using knowledge provided by prices, instead of by a central authority. The result would be “self-designing systems,” in which prices aid the process of convergence. In this case we would not want to fix design standards immediately, but rather wait to see how the design takes shape. This concept can be thought of as the economists’ version of second generation design methods (although Von Hayek was twenty years earlier).

Figure 2.1 gives us a picture of the relationship between supply and demand in the context of a changing transportation system design. The supply curve represents the supply of a new type of vehicle (such as lean vehicles) produced by the first vehicle supplier to enter the market. The vehicle supplier will not produce any vehicles unless the price is greater than its minimum long-run average cost, which occurs when average cost

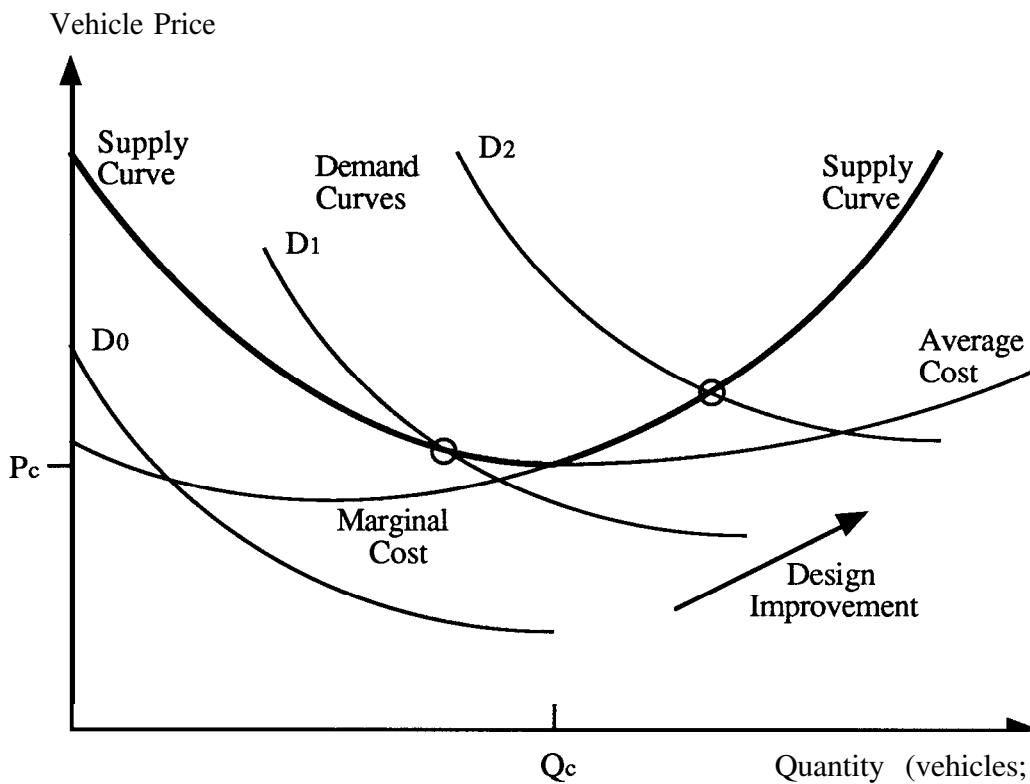

Figure 2.1. Vehicle supply and demand with a changing design.

equals marginal cost (shown by price P_c at quantity Q_c in Figure 2.1). There is only one supply curve (defined by the average cost curve to the left of Q_c and by the marginal cost curve to the right of Q_c) determined by the quantity of vehicles that will be produced at each price.

The demand curves represent the demand for these innovative vehicles. Facility suppliers can shift the demand curve by improving the system design. However, for a new system the design might not initially generate enough demand to cause the vehicle suppliers to produce, as shown by demand curve D_0 which does not intersect the supply curve. Demand curve D_1 intersects the average cost part of the supply curve and demand curve D_2 intersects the marginal cost part of the supply curve. If the design further improved, the equilibrium point would move up the marginal cost part of the supply curve, and eventually

other vehicle suppliers might enter the market. Thus, there are barriers to initiating this self-design process. The system might need a jump start to get the design up to the level at which there is a stable equilibrium. A model for the design process would also help vehicle suppliers decide whether or not to make the jump to production of innovative vehicles.

2.1.4. Ideas from Project Management

A variety of activity network techniques from the field of project management can be used for the planning and scheduling of projects. The most familiar of these techniques are the “Critical Path Method (CPM)” and the “Project Evaluation and Review Technique (PERT),” both of which were developed in the late fifties and were rediscoveries of ideas from “Harmonygraphs” developed by Adamiecki [193 1]. CPM was developed jointly by Kelley at Remington Rand Univac and Walker at the duPont Company for the purpose of reducing the time required for plant overhauls, maintenance operations, and construction projects [Kelley and Walker, 1959]. This technique involves a tradeoff between project duration time and total project cost. PERT was developed by the Lockheed Aircraft Corporation, the Navy Special Projects Office, and Booz-Allen & Hamilton for the purpose of accelerating the production of the Polaris missile system [Malcolm et al., 1959]. This technique involves uncertainty associated with the time required to perform an activity.

The basic idea of CPM and PERT is to break up the project into a number of smaller activities, each with a corresponding time estimate, cost estimate and resource requirements. An activity network diagram is then constructed which shows the relationships between the various activities; which activities must be completed before the next activities can begin, and which can be done at the same time. Once the activity network is drawn, the “critical path” can be determined. The critical path represents the string of activities which determines the minimum time to complete the project. The activities which are not on the critical path are said to have “slack” or “float time” (the amount of which can be calculated). “Perhaps the most ironic aspect of the Critical Path

Method is that after you use it, it is self-evident” [O’Brien, 1984, p. xiii]. CPM provides a discipline which forces consideration of what has to be done, when, by whom, and in what order [Lockyer, 1964].

2.2. Review of Activity Network Techniques

It seems obvious that the transportation system design process could be aided by the use of activity network techniques, since the design of a system could be thought of as a project with many separate but dependent activities. However, these techniques were not invented for and have not been used for the design of systems which evolve over time as the market grows. The goal of this research is to modify existing activity network techniques, invent new techniques, then combine them in ways suitable for the evolutionary design process. It should be emphasized that we are interested in activity networks as models for the design process, not as models of the design process. Activity network models of the design process would represent generic activities like those in the discussion of second generation design methods (divergence, transformation, convergence). We want to use activity networks as tools while we are designing a system: the activities will be specific actions that depend on the situation.

The following is a brief review of existing activity network techniques which are useful in the transportation system design process. Much of the material for this section comes from Moder, Phillips, and Davis [1983], which is the most comprehensive treatment of the subject.

2.2.1. Arrow Diagrams

Both CPM and PERT use “activity-on-arrow” diagrams to represent the network of activities. These network diagrams, sometimes called simply “arrow diagrams,” consists of “nodes” connected by “arrows.” The arrows represent activities which have corresponding completion times. The nodes represent “events” which define the beginnings and ends of activities. There are “branch events” which are followed by more

than one activity, and “merge events” which are preceded by more than one activity. In some networks “dummy activities” are required to establish the proper relationships between activities. These dummy activities are represented by dashed lines and do not take any time to complete. An example of an arrow diagram for a project with five activities is shown in Figure 2.2. This hypothetical network shows, for example, that activity A must be finished before activities B and D can start, and that both B and D must be finished before activity E can start. In this case a dummy activity was necessary to show that activity D cannot start until activity A is finished. The activity times are shown under the arrow for each activity.

Once the network is drawn, a “forward pass” through the network gives the early start and early finish times for each activity. The early start time for an activity following a merge event equals the maximum of the early finish times of the activities leading into the merge event. A “backward pass” through the network gives the late start and late finish times of each activity. The difference between the early start and late start (or early finish and late finish) times for each activity give the slack, or float time for that activity. The slack represents the amount of time that an activity can be delayed without delaying the completion of the overall project. For the simple example in Figure 2.2, the critical path includes activities A, D, and E, and takes eight days to complete. Activities B and C each have a slack of one day.

2.2.2. Precedence Diagrams

Another method of representing a network of activities is the “activity-on-node” diagram, in which case the nodes represent the activities. The activities are connected by arrows which simply show the relationships of the activities. The most popular technique that uses activity-on-node diagrams is the “Precedence Diagramming Method (PDM),” which was developed by Fondahl [1961]. An example of a precedence diagram, which represents the same five activity project that was discussed above, is shown in Figure 2.3.

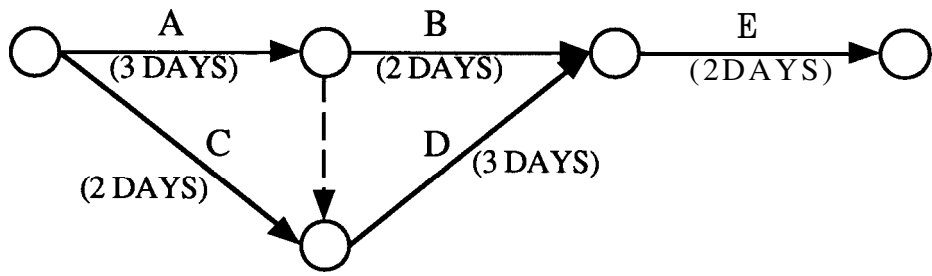

Figure 2.2. Arrow diagram (activity-on-arrow).

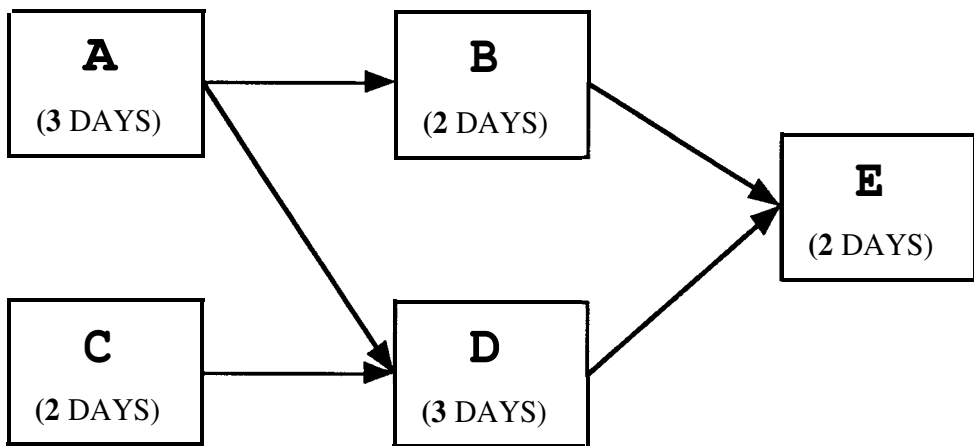

Figure 2.3. Precedence diagram (activity-on-node).

The critical path and slack results from this precedence diagram are the same as those resulting from the arrow diagram of the same project (Figure 2.2).

An added feature of precedence diagramming is the introduction of lag between activities (mentioned above) or overlap of activities by allowing different relationships between successive activities. These relationships include: finish-to-start, start-to-start, finish-to-finish, start-to-finish, and a combination of start-to-start and finish-to-finish. For example, a finish-to-start relationship with a corresponding time of two days introduces a lag of two days between the finish of the first activity and the start of the second activity. The other relationships require consideration of the activity duration times to determine whether there is lag or overlap. This feature helps to avoid splitting activities, thus fewer activities need to be included in the network diagram. On the other hand, since the connecting arrows with lag or overlap have several different definitions (relationships), the calculations are not as straightforward. Bennett [1977, pp. 6-7] discusses the advantages and disadvantages of precedence diagrams, which are listed below:

Advantages of Precedence Diagrams

1. Dummy activities are eliminated.
2. Networks are easier to understand, especially for beginners.
3. Modification of networks is easier.
4. Labelling of both arrows and nodes is eliminated, thus easier bookkeeping.
5. Line connecting two activities can have lag.

Disadvantages of Precedence Diagrams

1. Events are eliminated, which are important in some projects (milestones).
2. Most activity network techniques were developed for arrow diagrams, thus less experience, fewer computer codes, and fewer tricks exist for precedence diagrams (this is not as much of a problem anymore).

2.2.3. Time-Scaled Diagrams

A network of activities can also be shown with a “time-scaled” diagram which represents activities with arrows (or nodes) that are vectors with length proportional to time. This is an improvement over “Gantt Charts” (bar charts) which were developed by Gantt and Taylor for graphical representation of work versus time for World War I military use. Bar charts are limited because they don’t show relationships between project activities [O’Brien, 1984, p. 2].

The advantage of time-scaled diagrams is that the critical path and slack can be determined directly from the graph without calculation. A time-scaled arrow diagram, which represents the same five activity project discussed above, is shown in Figure 2.4. The horizontal dashed lines for activities B and C represent slack, and the vertical dashed line between activities A and D represents a dummy activity. A time-scaled precedence diagram for the same project is shown in Figure 2.5.

The disadvantage of the time-scaled method of representing the network is that the diagram must be redrawn as the project proceeds and whenever a change is made in the network or schedule. This disadvantage is most significant for projects with many activities when the network must be drawn manually (instead of by a computer program).

2.2.4. Resource Constrained Scheduling and Time-Cost Tradeoff

The activity duration times used in the above diagrams assume a normal level of resource use and that the resources are available. However, since projects usually involve simultaneous activities which could use the same resources, resource allocation can sometimes become a problem. There are two types of scheduling procedures for dealing with resource constrained problems. “Resource levelling” tries to reduce the variability of resource use without increasing project duration. However, when resource requirements exceed fixed limits, then “fixed resource limits scheduling” must be used to increase the project duration by a minimum amount [Moder, Phillips, and Davis, 1983, p. 202].

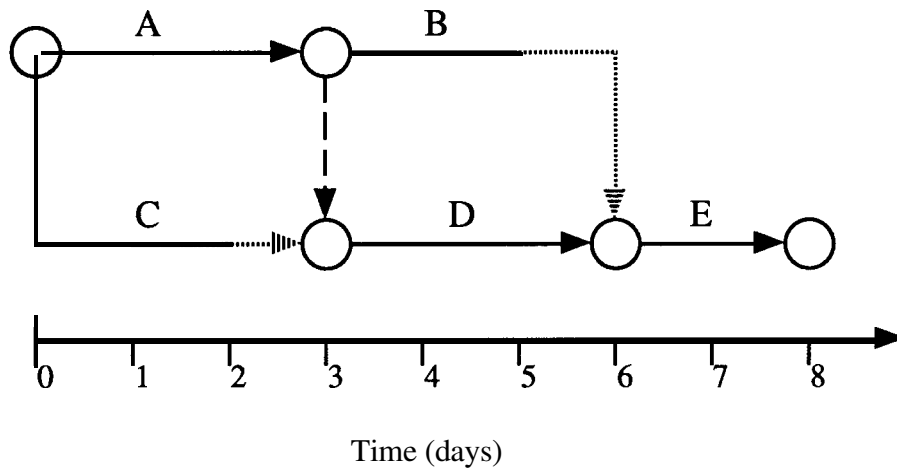

Figure 2.4. Time-scaled arrow diagram.

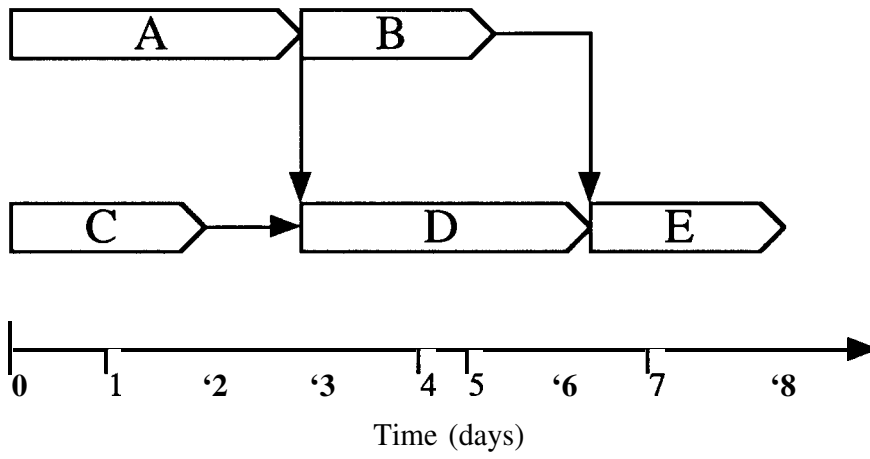

Figure 2.5. Time-scaled precedence diagram.

There is a tradeoff between activity duration time and activity cost, thus the project duration time can usually be reduced by the application of additional resources (if they are available). The idea is to buy time along the critical path at the least possible cost. There are several methods of finding the optimal time-cost tradeoff, the most notable of which is CPM. The CPM technique minimizes total project cost by using linear approximations for the relationships between activity costs and activity duration times. Other approaches to finding the optimum time-cost tradeoff, besides the “brute force” approach used in CPM, include linear programming and the flow approach, which solves the dual to the primal problem of linear programming [Whitehouse, 1973, p. 61].

2.2.5. Statistical Approaches

Both CPM and precedence diagramming use mean time estimates for the activity duration times, but the values actually have statistical distributions due to chance variations. The PERT method was developed specifically to consider the uncertainty associated with the time required to perform an activity. It uses a beta distribution to describe the duration time of each activity. The expected (mean) activity duration time is calculated using the estimates of three values: an optimistic time, a most likely time, and a pessimistic time. PERT calculates the critical path and the mean project duration time using only the expected values of the activity duration times. The project duration time is assumed to have a normal distribution due to the central limit theorem. A combination of precedence diagrams with activity duration time distributions was proposed by Moder, Phillips, and Davis [1983, p. 310], but not fully developed or described.

The PERT method introduces a “merge event bias problem” which underestimates the completion times at merge events by only considering the distributions of activities on the critical path in the calculations. The PNET approach [Ang, Abdelnour, and Chaker, 1975] takes care of this problem by also considering the “near critical paths.” The Monte Carlo simulation technique also does away with the problem by simulating all possible

paths through the network and calculating the probability that each path is critical [Moder, Phillips, and Davis, 1983, p. 271].

Experience has shown that much of the benefit of network techniques comes from drawing the activity network, thus methods which use only mean times are useful for the first step in a network approach, and it is not always necessary to make all the calculations associated with activity duration time distributions.

2.2.6. Probabilistic Branching and Looping

The arrow and precedence diagrams discussed above are based on deterministic network logic in which every path is necessary and there are no optional or alternative paths. Several techniques have been developed which allow probabilistic branching and looping in the network diagrams. Looping can be used to represent iterative steps and branches can be used to represent either decisions or chance outcomes. An example of an arrow diagram with probabilistic branching and looping is shown in Figure 2.6. The probabilistic branching following activity W is represented by a diamond. One outcome of the branch is activity X, which represents looping, and the other outcomes are activities Y and Z; each with a corresponding probability of occurrence. Figure 2.7 is a precedence diagram for the same project.

One activity network technique which includes probabilistic branching and looping is the “Graphical Evaluation and Review Technique (GERT).” GERT obtains solutions to stochastic network problems using a combination of PERT, moment generating functions, and flowgraph theory [Whitehouse, 1973, p. 243]. Moment generating functions are used to provide the mean and variance of a distribution (by taking derivatives). A flowgraph is a graphical way of showing the relationships among variables which are related by linear algebraic equations [Whitehouse, 1973, p. 163].

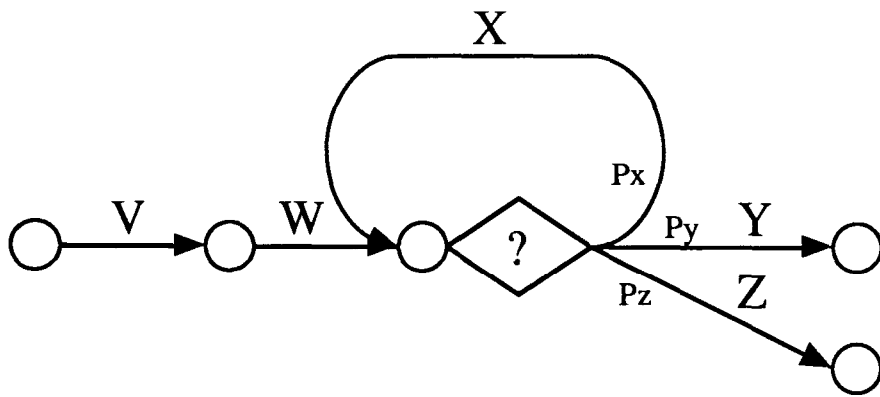

Figure 2.6. Arrow diagram with probabilistic branching and looping.

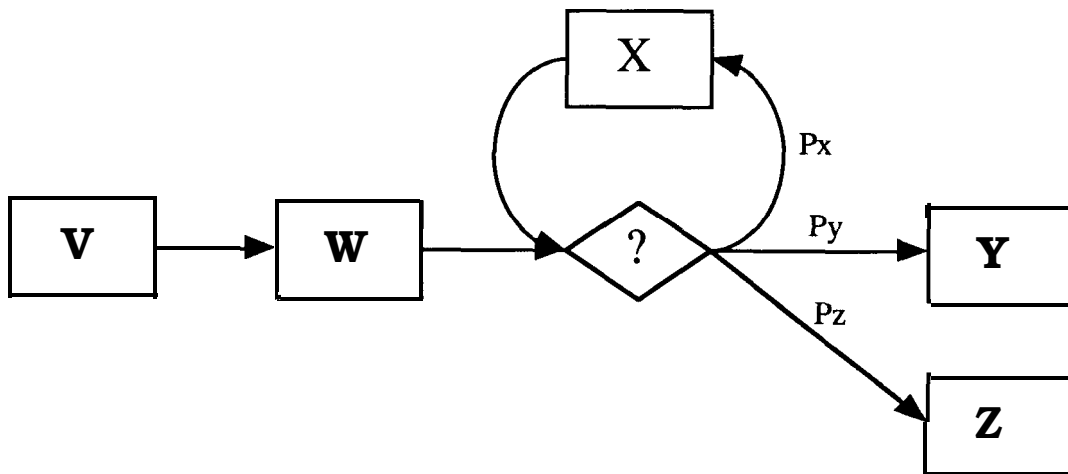

Figure 2.7. Precedence diagram with probabilistic branching and looping.

2.3. Application to Transportation System Design

Most applications of activity network techniques have been for construction projects, but there have been a few applications to “design” projects and research and development programs. Wingate [1966, p. 18] describes the application of CPM to the planning and design stages of a highway construction program involving multiple projects for the purpose of staff allocation within a highway authority. However, this “design” project used existing technologies and is not the type of evolutionary design project that interests us. Whitehouse [1973, pp. 409-415] describes the application of another network technique (GERT) to a research and development project for an individual technology. The basic premise behind this application is sound, but the approach is much too detailed and complicated to be useful in the lean vehicle design process, which involves mostly technologies that do not require as much research as described in this application.

The National Airspace System (NAS) plan, released by the Federal Aviation Administration (FAA) in 1982, represents an attempt at using activity network techniques for the design of a transportation system. It is a 20 year plan to meet the projected needs and demands of air traffic control and aviation safety. The plan identifies almost 100 facilities and equipment projects, as well as supporting research and development. An early General Accounting Office review of the NAS plan [U.S. GAO, 1983, pp. 10-1 1] recognized that its success depended on development and implementation of more than 30 time-sensitive and interdependent projects. The review called for an updating of the plan to include identification of project priorities and interdependencies of planned activities.

An audit of the NAS plan was performed in 1984 [Martin Marietta, 1984, pp. 1.3-1.81 to determine, among other things, if the individual and integrated schedules were achievable and properly phased in order to provide evolutionary growth in system capacity and capability. Even at the time of this early review, much of the slack time within individual projects had been eroded, which placed the overall program schedule in

jeopardy. A program master schedule was not in place and many individual project schedules were in need of expanded detail. The audit recommended critical path analysis for forecasting and reducing schedule conflicts, since expanded detail of the project schedules revealed dependencies between individual projects which were not identified in the overall project plan.

The critical path analysis appears to have been done to some extent but not completely or successfully. A comparison of earlier and later NAS plan documents [U.S. DOT/FAA, 1984 and 1989] reveals that CPM-like diagrams were added to the later report. However, these diagrams do not actually show the interdependencies among projects, they only show the sequence of bringing the projects “on-line.” Testimony in 1987 by the General Accounting Office to the U.S. Senate [U.S. GAO, 1987, pp. 1-5] noted that since the inception of the plan, all of the NAS plan systems had experienced delays ranging from one to eight years. Causes for the delays included underestimating the interdependency among the systems. This testimony also noted severe shortages in the FAA staff which would be needed to install the facilities and equipment of the NAS plan systems.

Obviously the critical path analysis was not successfully implemented in the above situation. The problem lies not with the activity network techniques themselves, but with the combination and application of the techniques. Although many activity network techniques were used with limited success in “first generation design methods,” they could become parts of an improved “third generation design method.” The following chapter outlines an activity network approach which combines some existing techniques and some new techniques in a method which is more suitable for the lean vehicle system design problem.

3. ACTIVITY NETWORK APPROACH

Activity network techniques can be used to improve the process of designing transportation systems that evolve to match the market (as would a system for lean vehicles). The approach is outlined below and consists of a combination of some existing activity network techniques, some modifications of those techniques, and some new techniques. As mentioned in Chapter 1, a system design can be considered as a package of many different technologies. In order for facility designers/suppliers to make decisions about which technologies to develop and when and where to implement them, they need to understand how the individual technologies fit into the overall process of the evolution of the design and the market. This changes the question of how to evaluate designs to a more appropriate question of how to evaluate individual technologies within the context of the overall design. Most technologies (at least those that will be used towards the beginning of the design evolution) will be similar to existing or previous technologies. The few technologies that are truly new can at least be envisioned and thus analyzed (but not necessarily with much precision or detail).

3.1. Activities and Dependencies

The general idea behind the activity network approach to design is to identify the activities related to each technology and the relationships between them. The activities required for each technology can be classified into three major categories:

1. Development.
2. Implementation.
3. Market growth.

All technologies have an associated “development” phase that actually involves several efforts, such as research, testing, and development. The development phase can also include activities and/or decisions required by other actors prior to implementation of the technology.

The “implementation” phase represents the application of the technology to a situation or the construction of the technology (if it is a facility). The implementation phase also includes any planning and site-specific design work which is necessary for implementing a previously developed technology in a new location or situation. For a technology already developed and implemented in one location or situation, the development phase would not have to be repeated.

The “market growth” phase represents the operation and maintenance of a particular technology in a particular location or situation, from the time of its initial deployment to the time of its eventual replacement by another technology. Implementation of a technology can be repeated, if necessary, while that technology is in the market growth phase.

A simple precedence diagram for an individual technology is presented in Figure 3.1. Every activity has corresponding estimates of the time, cost, and resources required to perform that activity. Each of the major activities can be further broken down to create an activity sub-network, as shown in Figure 3.2. The minor activities shown are those that were mentioned in the previous paragraphs; but there are undoubtedly others, and each could probably be further broken down. Thus, each major activity actually represents a sub-network of many activities with its own critical path. This sub-network can either be shown in its entirety, or represented by a single activity with appropriate parameters. The single activity representation is all that is necessary for this analysis, and it will be used throughout.

Figure 3.3 is an activity network representation of a “family” of related technologies for a hypothetical design situation (the origin of this network will be explained in Chapter 4). It is in the form of a precedence diagram, with each box representing an activity (development, implementation, or market growth) associated with a particular technology. There could also be generic development activities which apply to more than one technology, but that is not the case in this situation.

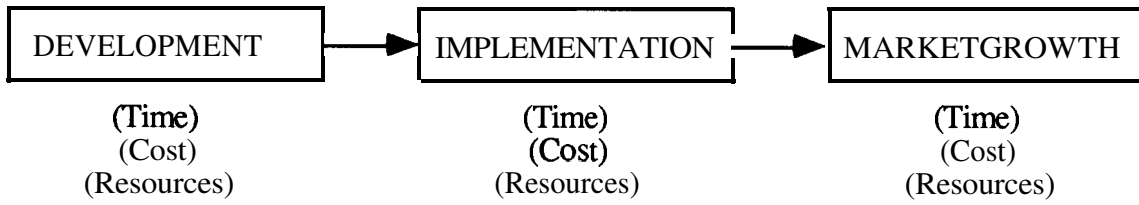

Figure 3.1. Major activities for each new technology.

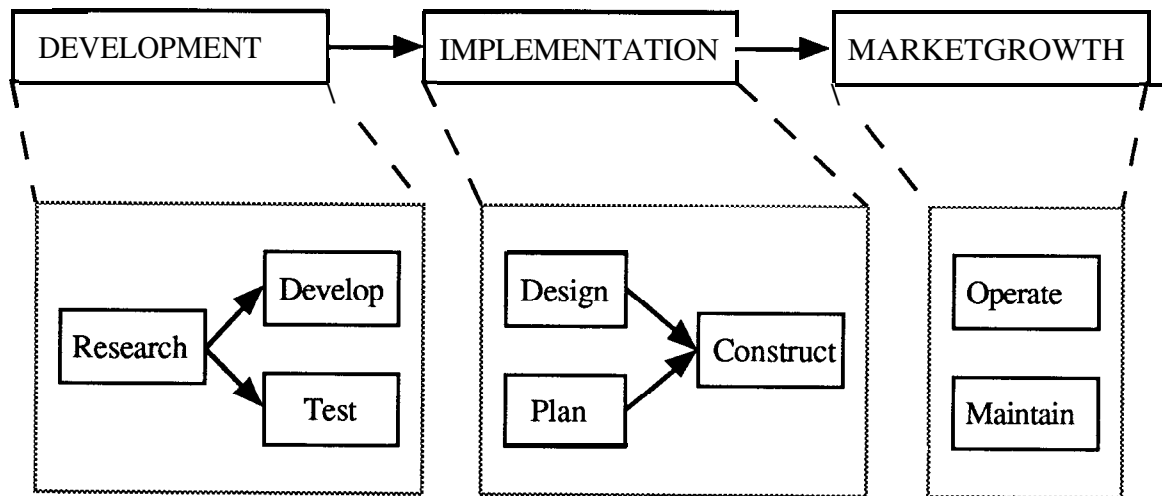

Figure 3.2. Expanded view of the major activities.

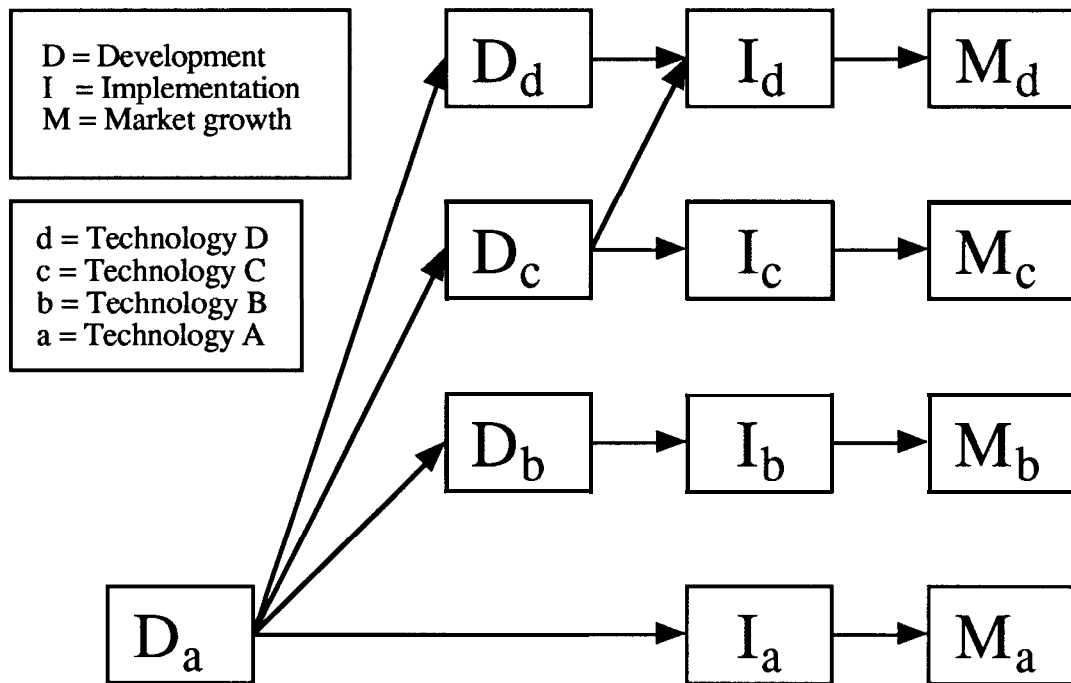

Figure 3.3. Unscaled precedence activity network for four related technologies.

The arrows connecting the boxes represent precedence relationships; they show which activities must occur before which others. This diagram can be referred to as an “unscaled” activity network, since there is no attempt to represent any dimension (such as the time, cost, or resources required to complete each activity). The diagram shows that the four technologies are not independent because development of technologies B, C, and D cannot begin until the development of technology A has been completed. Also, implementation of technology D requires prior completion of the development of technology C.

3.2. Approach Outline

The approach is to anticipate the incremental steps which could lead from the current design to some hypothetical but desired future design. The designer must be

conscious of the next step beyond any given step, and also the previous steps. The designer must be sensitive to the time lags involved and the continuous process of technology assessment which leads to market acceptance or rejection of individual technologies. Thus, in order to have the right facilities in the right place at the right time, facility designers need to estimate and constantly update projections for both existing and potential technologies regarding the following characteristics:

- A. How each technology depends on other technologies.
- B. Expected time and cost to develop each technology.
- C. Expected time and cost to implement each technology.
- D. Benefit of operating each technology.
- E. Feasible market range and market costs for each technology.
- F. Expected time for the market to grow through each market range.

With the above information it should be possible for the facility designer/supplier to guide and enable the design evolution with the use of activity networks.

A critical path from the “beginning” to the “end” of the project cannot be specified (as in a construction project for example), because the “end of the project” is undefined. Each technology has an “end,” and there can be several “beginnings” which can start at different times. Since potential technologies can be added to or deleted from the design, and since the associated parameters will be continuously revised, the activity networks and associated calculations can change over time.

All of the parameter estimates for completing the various activities (development, implementation, and market growth) have statistical distributions, but, as mentioned in Chapter 2, much of the benefit of activity networks comes from drawing the network, and it is not always necessary to make calculations related to the statistical distributions. When desired, further analysis (such as time-cost tradeoff, resource constrained scheduling, statistical approaches, or combinations of these) can be used to refine the calculations and accelerate the design process.

Determination of early or late deployment of technologies depends on the amount of resources available. Additional resources can be applied to accelerate the development and implementation phases, thus time-cost tradeoff analysis would be applicable. However, the market growth phase can not be accelerated, unless we consider the number of facilities deployed (which is indirectly related to market growth). An estimate for the time required for the market to grow through a given range depends, of course, on the projected market growth.

3.2.1. Market Range Calculations

The calculations to define the market range concern the context within which the design process operates. As such, the market range calculations tie the big picture to the snapshot. The big picture includes the relationship between design and market, and the interactions between the various actors involved in the design process (topics discussed in Chapter 1). The snapshot involves the activity network representation of the design situation which was discussed earlier in this chapter. In order to make the market range calculations, the activity network representation of the design situation must be drawn first. A network representing the overall system would be too complicated and is not necessary. The networks for families of related technologies can be drawn somewhat independently with perhaps a few interconnections to other networks.

Each technology is assumed to be feasible for a certain range of market levels. These market levels represent quantities at supply/demand equilibrium points. The market range is defined by a lower limit and an upper limit (the upper limit may or may not exist). The lower market range limit is the market level at which a particular technology attains a balance of payments that is favorable, or at least acceptable, to all the actors involved in making decisions which determine the success of that technology. The upper market range limit (if one exists) is the market level at which the technology becomes unfavorable or unattractive, such as when “congestion” occurs or when another technology becomes more

attractive. The market range of a technology will probably overlap the range of other technologies, and these technologies can even coexist at the same time but in different locations.

An outline of the market range calculations is shown in Figure 3.4. The goal is to have the total marginal benefit provided by each technology, B_x , exceed the total cost of supplying that technology, C_x ,

$$B_x(m) \geq C_x(m) \cong C_x \quad (3.1)$$

where the total benefit is assumed to depend strongly on the market level, but the total cost is assumed to be nearly independent of the market level. Figure 3.5 shows how total benefits and costs might vary with market level. Whether the curves intersect once, twice, or not at all (or whether they are nearly tangent) depends on the magnitude and shape of each curve. If the curves do intersect then a break-even point is established which defines either a lower or an upper limit.

The term “benefit” refers to the net change in consumers’ surplus or utility, if we are considering a public system for which costs may not be fully recoverable. If we are considering a private system for which costs can be recovered through pricing, then “revenue” can be used as an estimate of benefit (although revenue is an underestimator of consumers’ surplus). The benefit to an individual user might decrease as market levels increase, and in fact the total benefit might decrease at high market levels if an additional user imposes disbenefits to other users that are greater than the individual’s benefit. The benefit of any technology can have several components, k , representing such things as time savings, resource savings, enhanced safety, or better information. Different technologies will have different benefit components, but the total benefit is always the sum of the various components.

$$B_x(m) = \sum_k B_x^k(m) \quad (3.2)$$

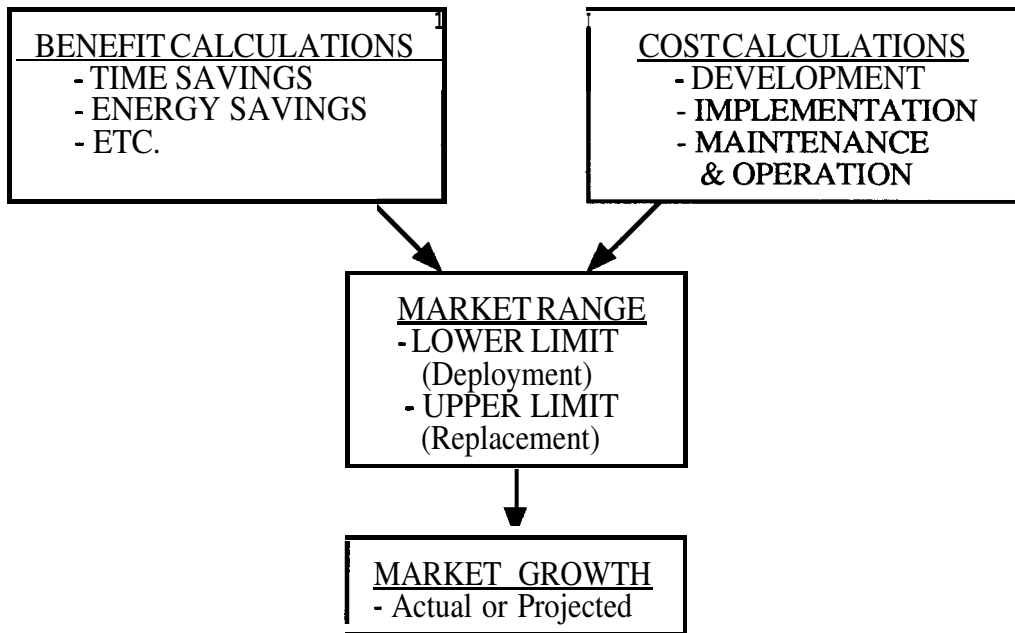

Figure 3.4. Market range calculations.

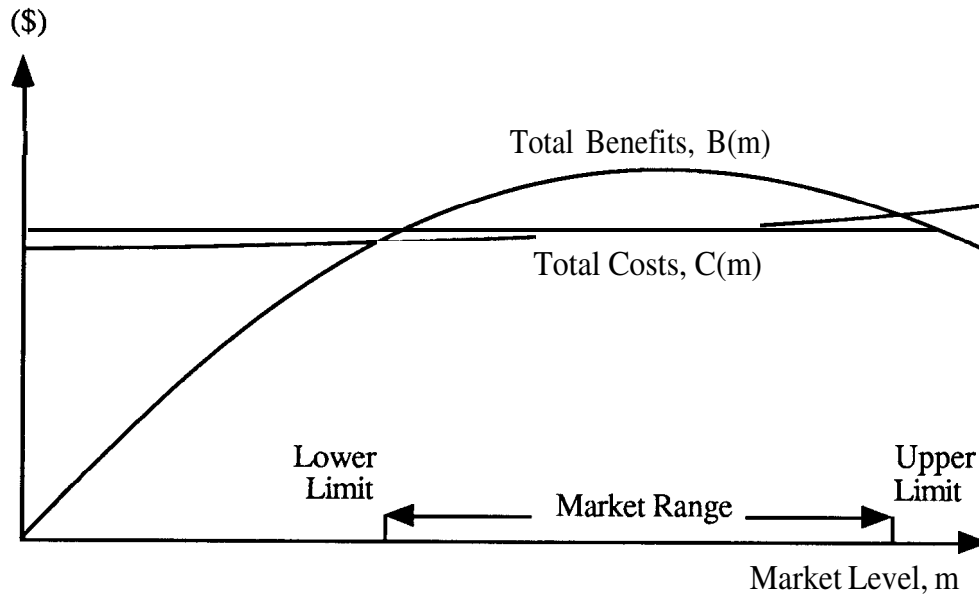

Figure 3.5. Total benefits and costs versus market level.

The term “cost” refers to the full cost of supplying a technology, which can be greater than the cost passed on to users through prices (especially for a public system). The total cost of each technology has components for each of the major activities: development, implementation, and market growth (parameters are defined in Table 3.1).

$$C_x = \sum_z^x C_z^D + \sum_y^x C_y^I + C_x^M \quad (3.3)$$

The development cost for technology x actually includes development costs for all technologies, z , that must be developed prior to implementation of technology x . Similarly, the implementation cost includes implementation costs for all technologies, y , that must be implemented before market growth of technology x . For the example in Figure 3.3, technologies A, C, and D must all be developed before implementation of technology D, but only technology D has to be implemented before market growth of technology D. The market growth cost includes maintenance and operation costs; thus, it is most likely to depend on market level, but we will assume that the variable component is small compared to other cost values.

Before calculating the market range limits, the idea of strategies must be introduced. Strategy zero (also referred to as “Strategy 0”) considers all related technologies, compared independently to the current situation. Technology dependencies are considered, but each technology is assumed to be implemented by itself. Other strategies (1, 2,...) are combinational and consider logical groupings of several technologies in a particular order. The market limits for strategies other than strategy zero depend on the combination and order of implementation of technologies, which introduces other considerations that will be discussed later in more detail.

The lower market limit, L_x^0 , and the upper market limit, U_x^0 , for strategy zero are the market levels where the benefits equal the costs (break-even points).

$$B_x(L_x^0) = C_x = B_x(U_x^0) \quad (3.4)$$

Table 3.1 Technology Activity Parameters

Parameter	Description
D_x	Development activity for technology x ^a
I_x	Implementation activity for technology x
M_x	Market growth activity for technology x
T_x^D	Time required to develop technology x
T_x^I	Time required to implement technology x
T_x^M	Time for market growth of technology x
C_x^D	Cost of developing technology x
C_x^I	Cost of implementing technology x
C_x^M	Cost of market growth of technology x
R_x^D	Resources for development of technology x
R_x^I	Resources for implementation of technology x
R_x^M	Resources for market growth of technology x
$B_x(m)$	Benefit of technology x at market level m
U_x^j	Upper market limit for technology x with strategy j ^b
L_x^j	Lower market limit for technology x with strategy j
F_x^j	First application limit for technology x with strategy j
Z_x^j	First application cut-off for technology x with strategy j

^a Subscript x is an indicator for the individual technology.

^b Superscript j is an indicator for the strategy number ($j = 0, 1, 2, \dots$). Strategy 0 considers all individual technologies, compared independently to the current situation. Strategies 1, 2, ... consider any logical grouping of several technologies in a particular order.

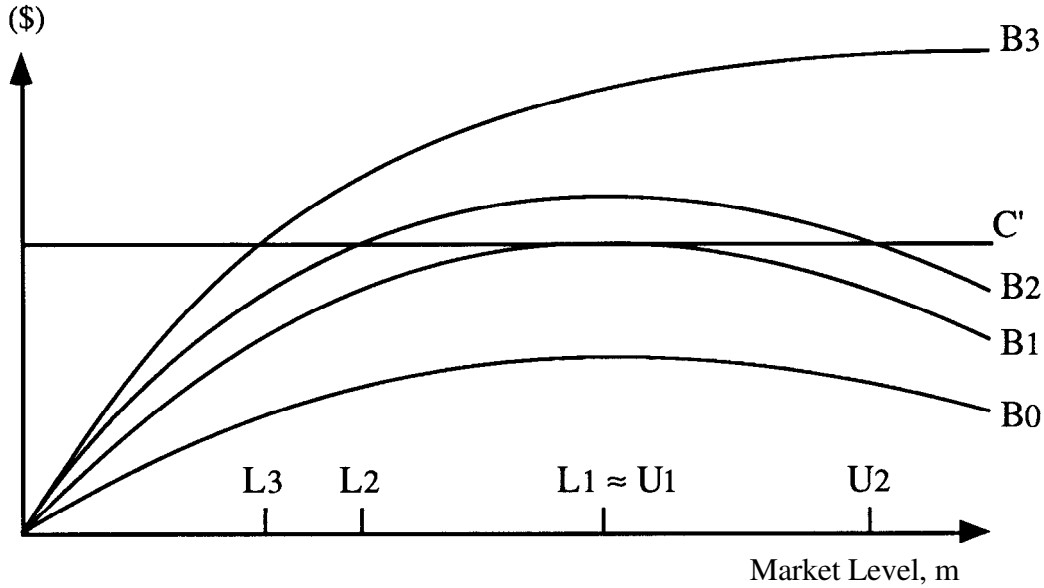

Figure 3.6. Lower and upper market range limits.

In this case, we consider only the implementation and market growth costs.

$$C'_x = \sum_y^x C_y^I + C_x^M \quad (3.5)$$

The market limits are found by taking the inverse of the benefit function.

$$L_x^0 = B_x^{-1}(C'_x) \quad (3.6)$$

$$U_x^0 = B_x^{-1}(C'_x), U_x^0 > L_x^0 \quad (3.7)$$

The market range limits for four possible benefit curves are shown in Figure 3.6. Benefit curve **B**₀ does not intersect the cost curve (a straight line), so there is no break-even point. Curve **B**₁ is nearly tangent to the cost curve, so the upper limit is about the same as the lower limit in this case. Curve **B**₂ intersects the cost curve at two points, defining the lower and upper limits, and the benefits exceed the costs in between the limits. Curve **B**₃ intersects the cost curve only once; thus, there is a lower limit but the upper limit is undefined.

The upper and lower market range limits defined in (3.6) and (3.7) are soft. A technology can be deployed below its lower limit with “subsidy” and can operate above its upper limit with “congestion”, in which case market limits are defined by considerations other than benefits and costs. For instance, the upper market limit might be defined by a physical limit, or the lower limit might be defined by some minimum level (such as “one unit”). Technologies can remain in operation after the upper (physical) limit is exceeded, but the excess market will either spill over to other facilities or it will not be served.

3.2.2. First Application Limits

The first application limit is another break-even point which considers development activity costs in addition to implementation and market growth costs. This limit is considered separately because subsequent applications of a particular technology might not have to share the development costs. The first application lower limit for strategy zero, F_x^0 , is the market level where the total benefit equals the total cost, including the development costs.

$$B_x(F_x^0) = C_x \quad (3.8)$$

(A first application upper limit might also exist, but it is not very meaningful.)

In some cases, the total cost can exceed the maximum benefit, B_x^{\max} ,

$$C_x > B_x^{\max} = \text{maximum}\{ B_x(m) \} \quad (3.9)$$

in which case it may be necessary to implement the technology more than once to recover the development costs (which are incurred only once). Thus, the first application limit is defined by

$$\text{NO, } B_x^{\max} \geq C''_x + N_x^0 C'_x = B_x(F_x^0) \quad (3.10)$$

where the development cost is

$$C''_x = \sum_z^x C^D_z = C_x - C'_x \quad (3.11)$$

and N_x^0 is an integer, greater than or equal to one, representing the number of times the technology must be implemented. Equation (3.10) assumes that the maximum benefit and the costs are constant for each application. This assumption could be relaxed for generality, but then the following equations could not be derived explicitly.

The inequality in (3.10) must be solved first to determine N_x^0 ;

$$N_x^0 \geq \frac{C''_x}{B_x^{\max} - C'_x} \quad (3.12)$$

then the equality in (3.10) can be solved to find the first application limit

$$F_x^0 = B_x^{-1}(C''_x + N_x^0 C'_x) \quad (3.13)$$

The determination of first application limits for combinational strategies (strategies 1, 2,...) will be discussed later.

3.3. Scaled Precedence Activity Network (SPAN) Diagrams

The activity time and market range estimates are best represented in graphical form. The basic idea is to use the results to create scaled activity networks. This research investigates an original technique: the use of scaled precedence activity network (SPAN) diagrams with dimensions of time and market level.

3.3.1. Time-Scaled Diagrams

The idea of the two-dimensional time and market scaled diagram was inspired by the (one-dimensional) time-scaled diagram. Since the cost estimates are embodied in the market range calculations, it might be possible to use time as the only dimension if we consider that it would take a certain amount of time for the market to grow through this range. Figure 3.7 is a bar chart of the design situation depicted in Figure 3.3. The bar chart shows how the technologies might be developed, implemented, and operated over the course of time, but it does not show the activity dependencies. A time-scaled activity network for the same situation is presented in Figure 3.8. It is similar to the bar chart except that it includes precedence relationships from Figure 3.3.

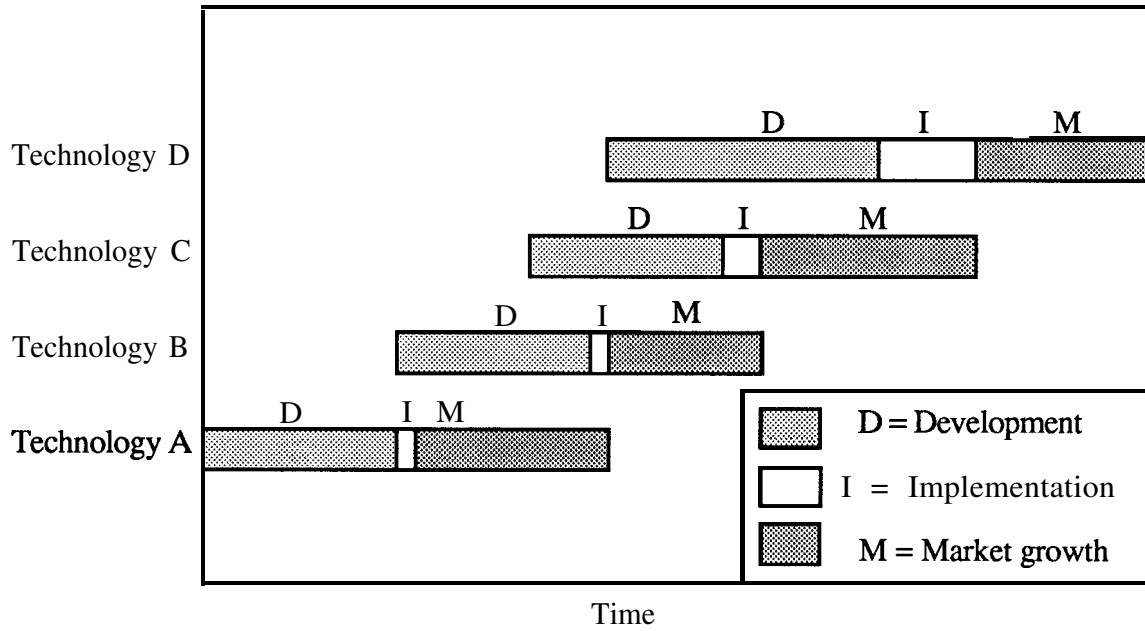

Figure 3.7. Bar chart (Gantt chart) for four related technologies.

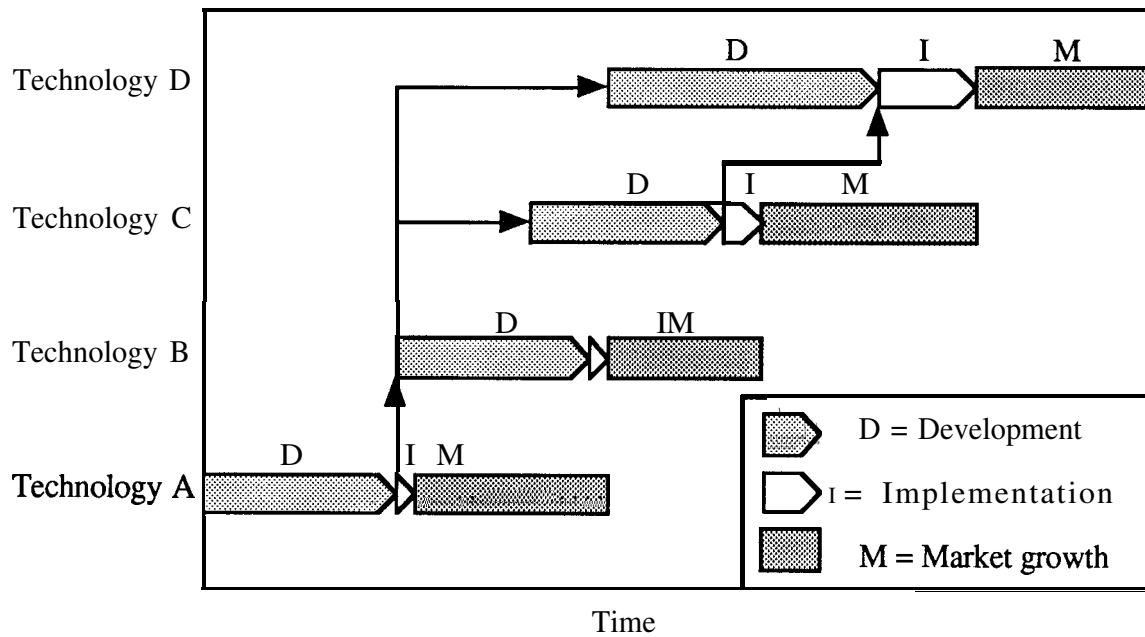

Figure 3.8. Time-scaled precedence activity network with activity dependencies.

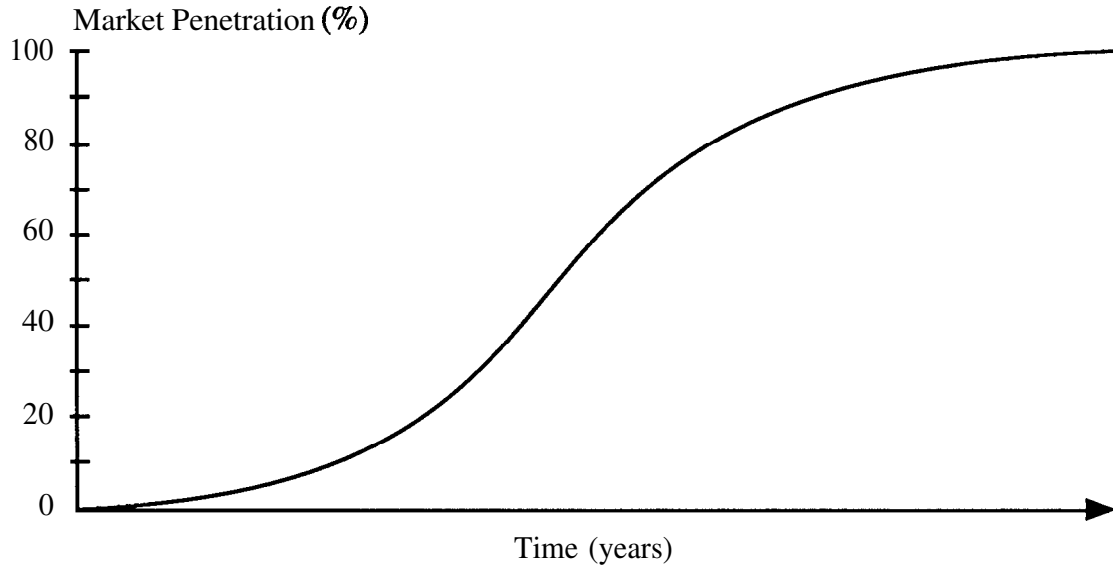

Figure 3.9. S-shaped logistic curve for market growth.

Unfortunately, the time-scaled diagram is misleading for the market growth phase because the time for the market to grow through the market range of each technology depends on the projected market growth. Furthermore, it is difficult to predict the market growth, probably much more difficult than estimating the activity time and cost values.

Figure 3.9 shows how the market level for a new system (like a lean vehicle system) might grow over a period of years. History shows that the curve of market penetration versus time will probably be S-shaped: a logistic curve. The 100% market level does not mean that the new system will entirely replace the old system, it simply represents the maximum penetration in the market. Although the market growth for a new system will not necessarily follow an S-shaped curve, such a curve could be used in the design process as a first approximation for the purpose of forecasting the long-range market growth. The problem is that we don't know the maximum penetration and we don't know how long it will take to reach that level or any other market level. Furthermore, the market growth over a shorter period (say, weeks or months) is unlikely to follow the S-shaped curve very closely. Thus, for short-range planning it is necessary to measure the market level to determine the present status in relation to the forecast.

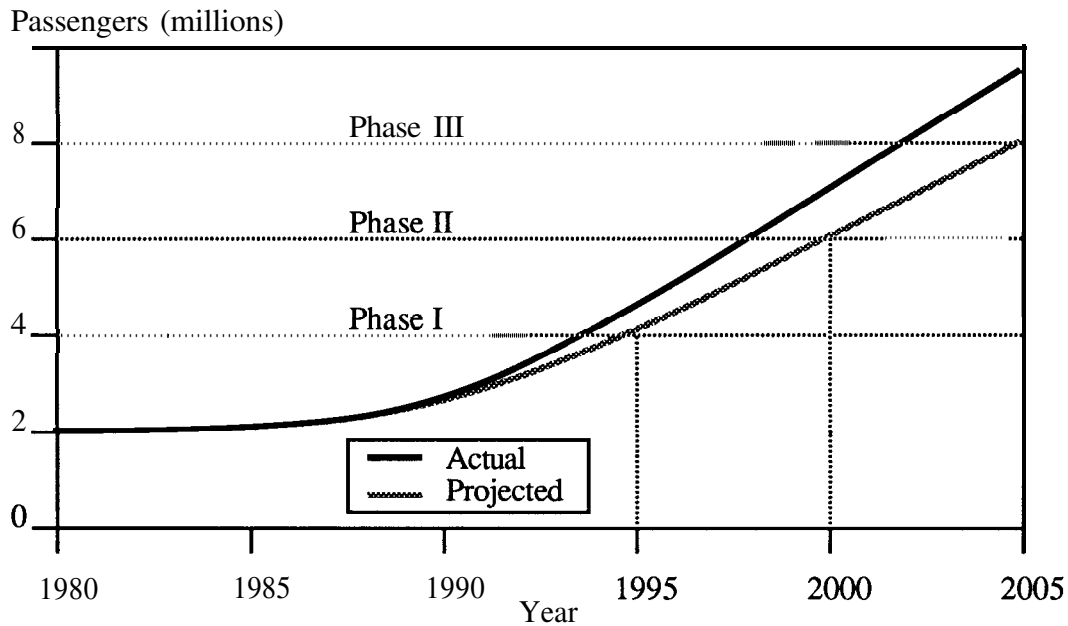

Figure 3.10. Phased design for an airport.

The strategy is similar to that used by airport designers. They forecast the passenger loads and produce a staged design for the airport which matches specific passenger loads (Figure 3.10). Whether or not the passenger load grows as predicted is not important as long as the proper design stage can be implemented in time to handle the actual passenger load. Figure 3.10 shows that phases I, II, and III at a hypothetical airport might need to be implemented in the years 1993, 1997, and 2002 instead of 1995, 2000, and 2005 as originally predicted.

3.3.2. Time and Market Scaled Diagrams

The previous figures and discussion suggest that we should use a two-dimensional representation of the scaled precedence activity networks. One dimension will be that of time, which we can estimate directly for implementation and development activities. The other dimension will be some measure of the market level for the market growth activities. This market level dimension shows the market ranges for each technology without reference to time. The market ranges are fixed relative to the market level axis, regardless

of the projected market growth. All technologies for a particular design situation could be shown on the same SPAN diagram to represent the overall design, but that could get confusing since there would be much overlapping of activities on the diagram. It is more informative to show only related technologies (“families”).

Figure 3.11 is a two-dimensional time and market scaled activity network representation of the hypothetical design situation for strategy zero (all technologies compared independently to the current situation). This SPAN diagram takes into account the relative time required to complete each activity (the time span), and the market range of each technology (the market span). The horizontal length of each development and implementation activity represents the required time for that activity. The vertical thickness of these activities is arbitrary, and there is no particular significance to the vertical position of these activities. Connecting arrows between activities represent precedence relationships which cannot be altered. The horizontal thickness of the market growth activities is arbitrary, but the vertical height and position represent the market range.

Implementation of technologies is shown at the first application limit (indicated by a horizontal line across the market range bar) for the sake of clarity. The first implementation of a technology does not have to wait until the market reaches the first application limit (it could occur at any market level), but it does have to wait until the necessary development activities are completed. Market growth activities are shown at the earliest possible time, as indicated by the horizontal position of the market range bars in the figure.

The SPAN diagram shown in Figure 3.11 includes development activities which must be completed before the technologies can be implemented the first time. However, the development activities will not have to be repeated for subsequent applications of the technologies. SPAN diagrams can also be drawn without development activities, as shown in Figure 3.12. This diagram is representative of the situation once the development activities have been completed; implementation can begin immediately. In this situation there are no other precedence relationships, so the technologies can be implemented

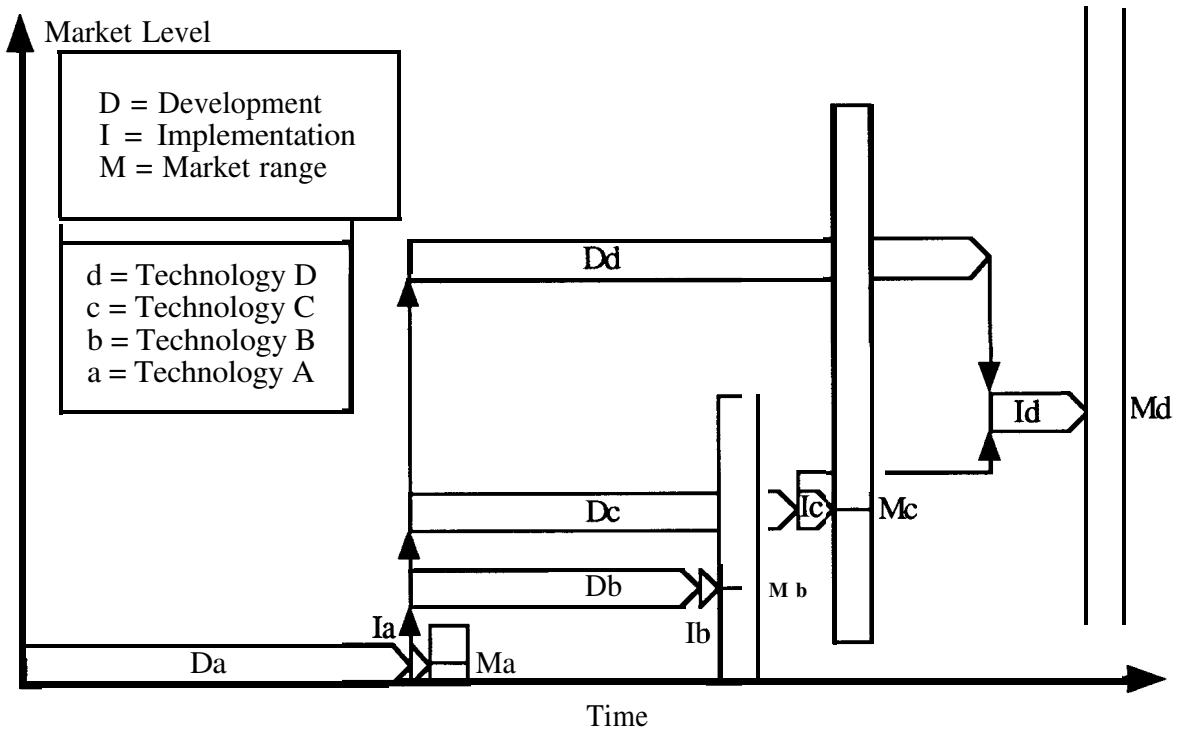

Figure 3.11. SPAN diagram for four related technologies (strategy zero).

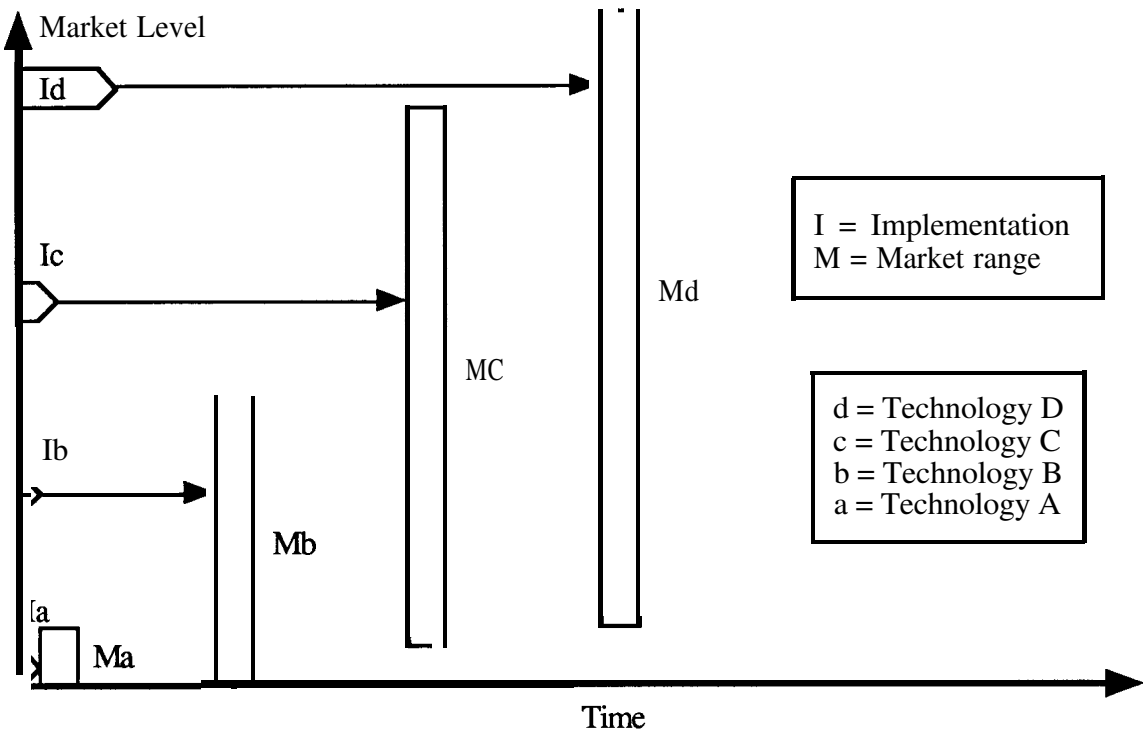

Figure 3.12. SPAN diagram without development activities (strategy zero).

independently, but this is not always the case. Some of the market range bars have been displaced horizontally to prevent overlap in the diagram, because the implementation times do not differ greatly. This artificial slack time is arbitrary and meaningless but is introduced to prevent, for example, the market range bar for technology A from being right on top of the market range bar for technology B.

3.3.3. Combinational Strategies

What can we learn from the SPAN diagrams for strategy zero? The diagrams show us how soon a technology can be developed (if necessary) and implemented, and the market range of each technology compared to the current situation: the definition of strategy zero. SPAN diagrams also allow us to identify logical strategies for implementation (strategies 1, 2,...) which combine several technologies in a particular order - strategies which span the gap between the current market level and some greater level.

Technologies are considered as competitors in these combinational strategies. The upper limit of one technology could be defined as the market level where another technology becomes more cost effective, which in turn defines the lower limit for the other technology. Cost effectiveness is determined by the amount by which benefits exceed costs. However, technologies do not necessarily have to be replaced immediately when they become less cost effective. Other considerations, such as safety or equity, can be more important than cost effectiveness for some strategies.

For combinational strategies (strategies 1, 2,...) that involve replacing one technology with another, the upper market limit for a technology cannot exceed that for strategy zero.

$$U_x^j \leq U_x^0, \quad (j = 1, 2, \dots) \quad (3.14)$$

If several technologies are operated simultaneously in the combinational strategy, then the upper limits for these technologies are added together to get upper limits for the combinational strategy.

A combinational strategy for the hypothetical design situation shown in Figures 3.11 and 3.12 might consist of technologies A, B, C, and D implemented in alphabetical order. SPAN diagrams, with and without development activities, for this strategy (strategy one) are shown in Figures 3.13 and 3.14. In this strategy, each technology is assumed to operate up to the upper limit from strategy zero. Thus, the upper limits for strategy one are equal to those from strategy zero, and the lower limit for each technology is equal to the upper limit of the previous technology.

It is necessary to recalculate the first application limits to reflect the combination of technologies. The first application limit of the first technology in the strategy is the same as for strategy zero, but the limit can be different for the other technologies depending on the relative values of the **first** application limit and upper limits for previous technologies, and the choice of what to do when those limits are reached.

The results from one particular basis allow us to determine if all the development and implementation costs for a given strategy can be recovered at a single location. For this basis, the first application of a technology should operate up to the first application cut-off, Z_x^j , which determines when to shift to the next technology for each of the three cases described below.

$$Z_x^j = \text{maximum} \left\{ U_x^j, \text{minimum} (U_x^0, F_x^j) \right\}, \quad (j = 1, 2, \dots) \quad (3.15)$$

$$Z_x^j = \begin{cases} U_x^j, & \text{Case 1: } F_x^j \leq U_x^j \\ F_x^j, & \text{Case 2: } U_x^j < F_x^j < U_x^0 \\ U_x^0, & \text{Case 3: } F_x^j > U_x^0 \end{cases} \quad (3.16)$$

Case 1. If the first application limit is less than the upper limit for strategy j , the technology remains in operation until that upper limit is reached. In this case, all the development costs are recovered before the upper limit is reached, but extra benefits do not go towards paying off the development of the next technology.

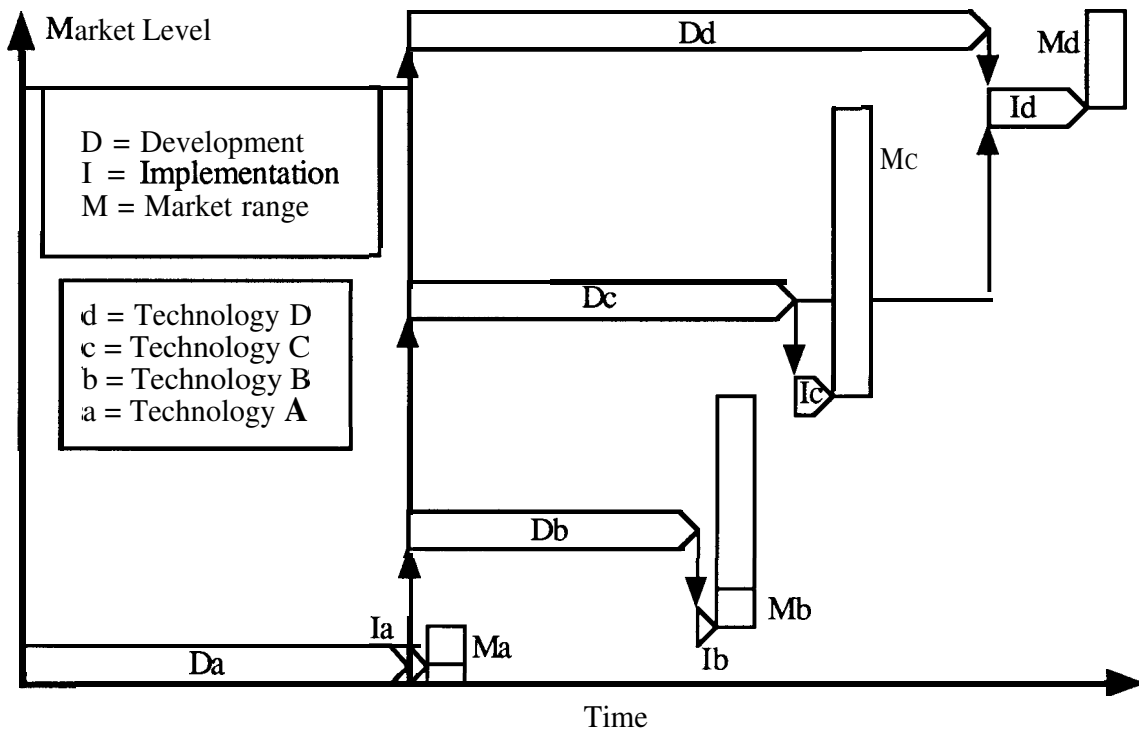

Figure 3.13. SPAN diagram for strategy one.

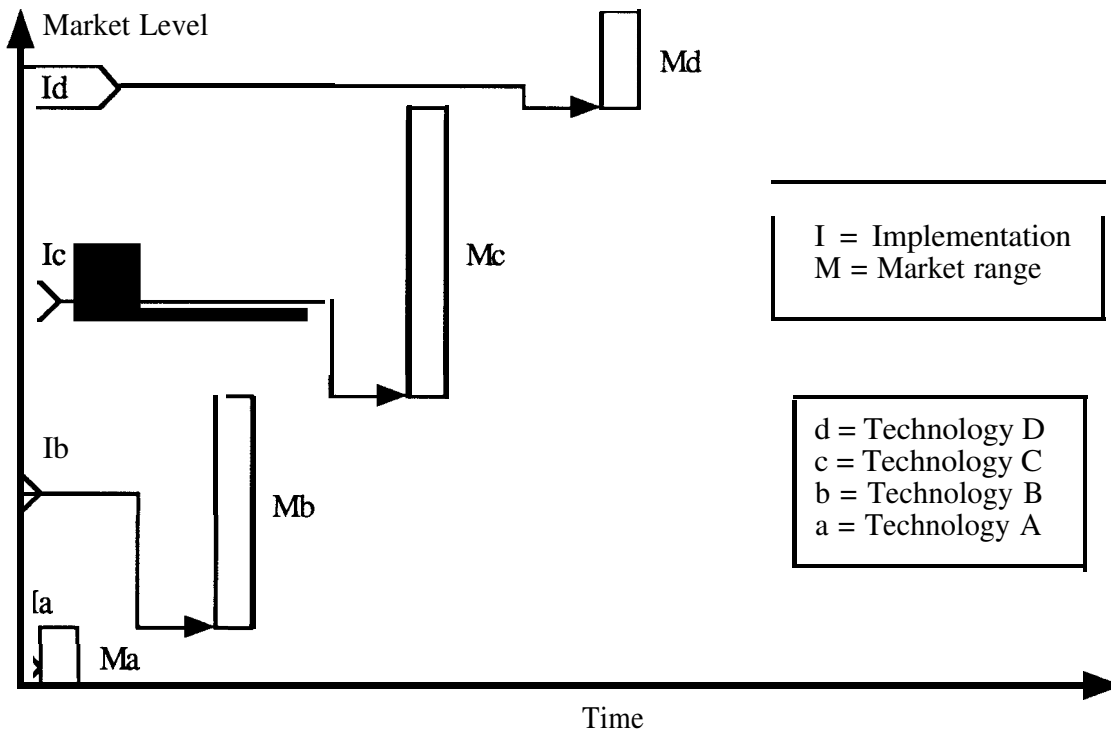

Figure 3.14. SPAN diagram without development activities for strategy one.

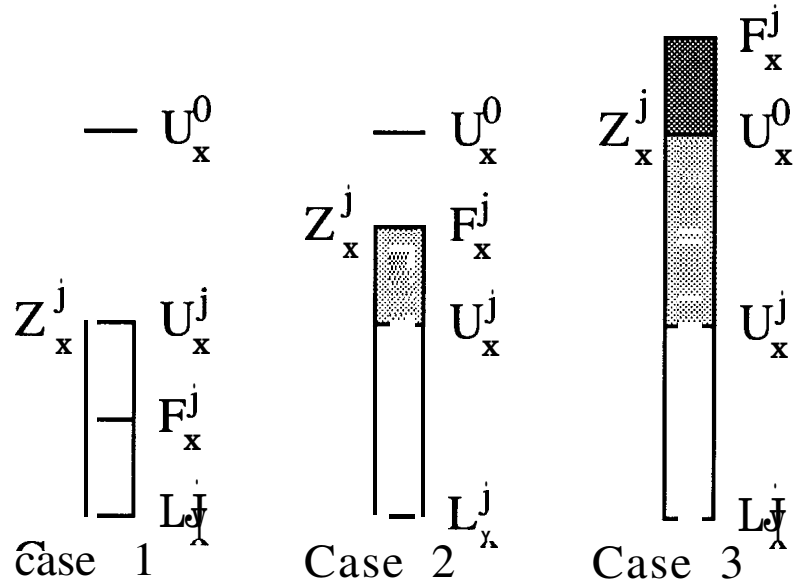

Figure 3.15. First application limit compared to upper limits ($j > 0$).

Case 2. If the first application limit is between the two upper limits, the technology operates above the upper limit of strategy j only until the break-even point is reached. In this case the development costs are just barely recovered before switching to the next technology.

Case 3. If the first application limit is greater than the upper limit of strategy 0, the technology operates only until that upper limit is reached. In this case some of the development costs will have to be recovered by the other technologies at the same location.

These three cases are illustrated in Figure 3.15, which shows the first application cut-off for each case. When the cut-off exceeds U_x^j (cases 2 and 3) the difference is shown as a lightly shaded area. When the first application limit exceeds U_x^0 (case 3) the difference is shown as a darkly shaded area.

The basis described above will be used for calculations in this research because it presents the most challenging first application limits. Other bases for calculating the first application limits for combinational strategies are possible, but they involve spreading development costs over multiple implementations resulting in less meaningful first application limits.

3.3.4. Using SPAN Diagrams

What else can we do with SPAN diagrams? Imagine a market growth curve superimposed on a SPAN diagram. We can consider two applications: a SPAN diagram defines how fast (or slow) the market can grow, and a market growth curve defines how fast (or slow) the technologies should be developed and implemented (if possible).

SPAN diagrams for strategy zero define the maximum rate of growth which can be accommodated by the technologies. These diagrams cannot be compressed beyond what is allowed by the activity times and precedence relationships. Maximum growth is defined by implementing a technology as soon as it is developed, at a market level equal to the upper limit of the previous technology. The maximum growth accommodated by the hypothetical design situation is shown in Figure 3.16. Of course, the market growth can exceed this “maximum” curve with congestion or spillover as described earlier in this chapter.

On the other hand, the SPAN diagrams can be used to arrange the order of deployment of technologies by matching their market ranges to a projected market growth, which can be shown on the same diagrams. However, rules for moving technologies around on the diagram must first be established. We can then determine when to start developing a technology so that it is ready to be deployed when the market reaches the appropriate level. The SPAN diagrams for combinational strategies are probably best suited for this approach.

SPAN diagrams are not rigid and can in fact be stretched to match a slower rate of market growth by delaying development and/or implementation, as shown in Figure 3.17,

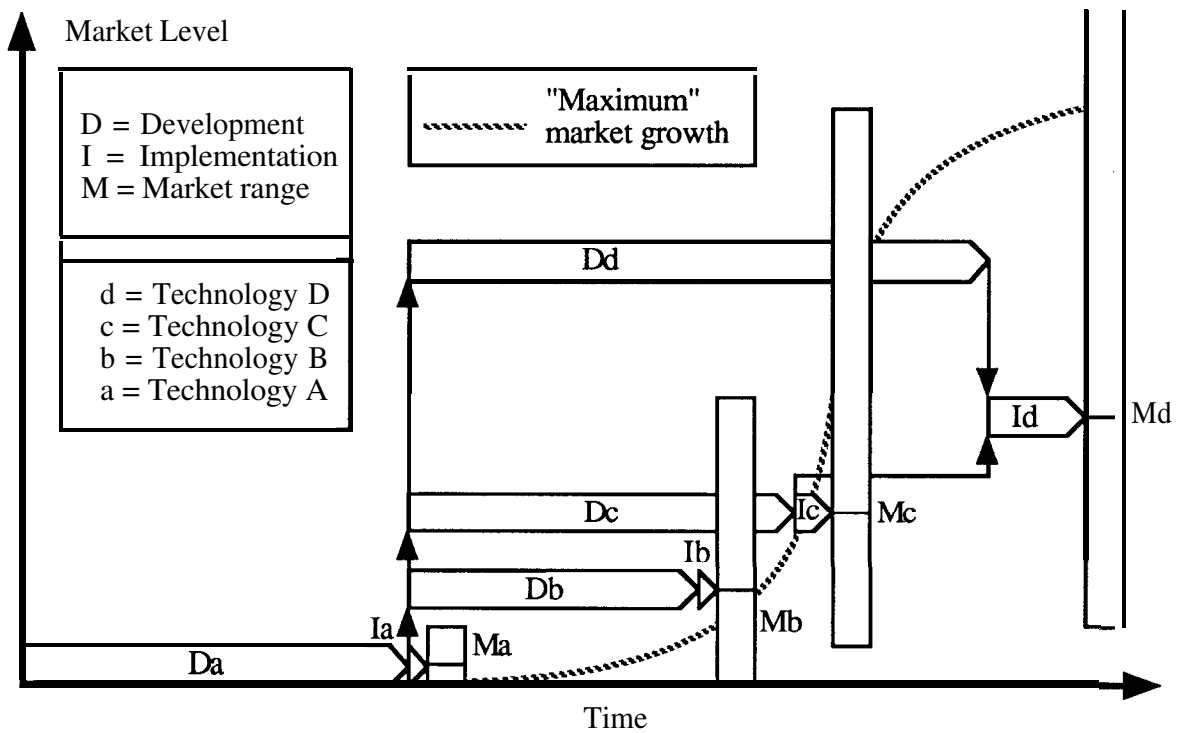

Figure 3.16. SPAN diagram with “maximum” market growth curve.

or by introducing slack time between implementation of already developed technologies. Figure 3.17 shows how the four technologies would be implemented with the particular projected market growth shown in the figure.

3.4. Comparison with Current Design Approach

Facility designers don't currently use an activity network approach nor do they need to because they are working for the most part with existing technologies. If and when a new technology is developed they simply incorporate it into their bag of tricks. The time required to implement a technology is still important, but the development phase is no longer necessary and the relationship to previous technologies is no longer important. The facility designers might forecast market levels and perform benefit/cost calculations ahead of time for the next technology they plan to implement in a particular location, but they rarely think beyond the next technology. Even planning for the next technology is often

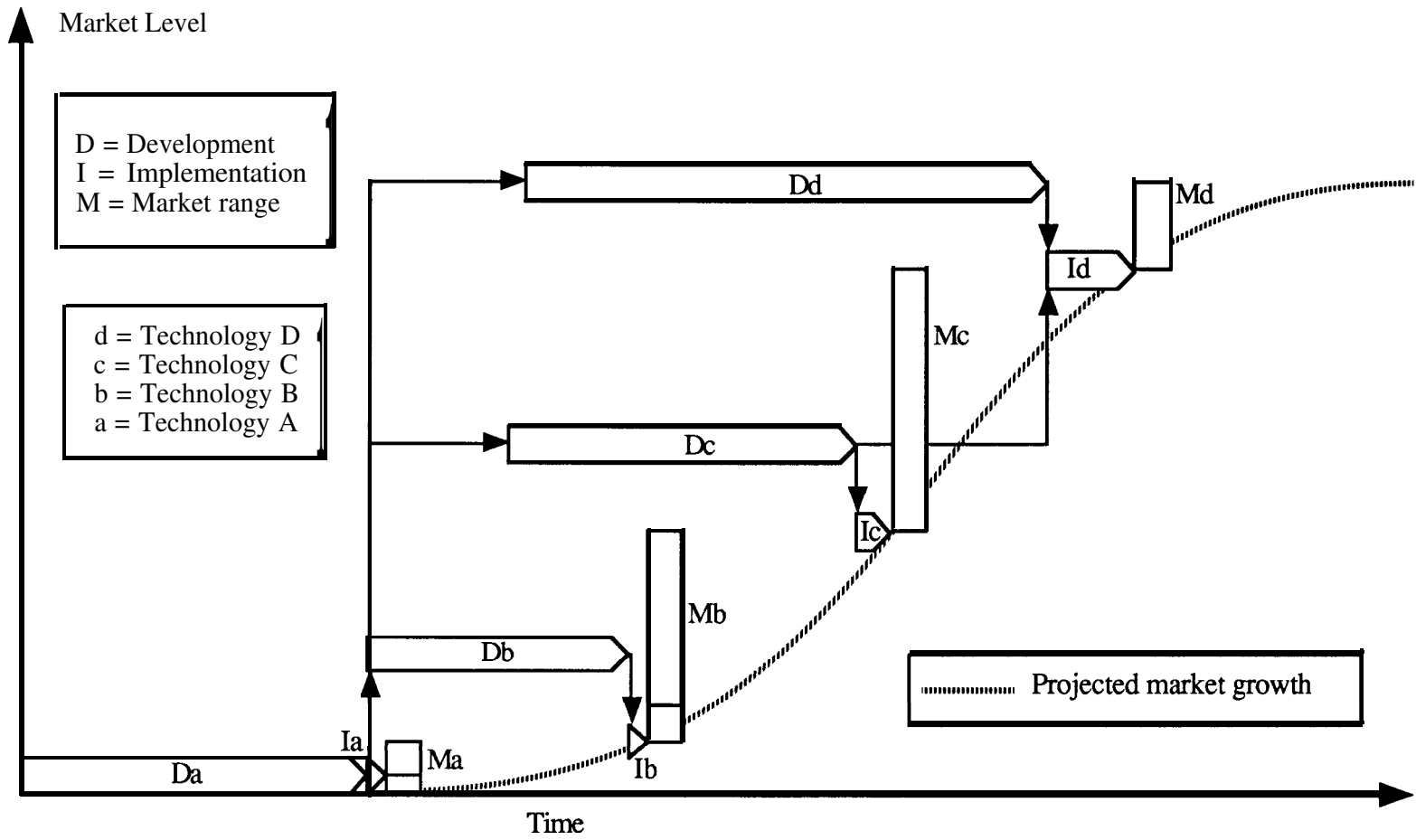

Figure 3.17. Stretched SPAN diagram for strategy one.

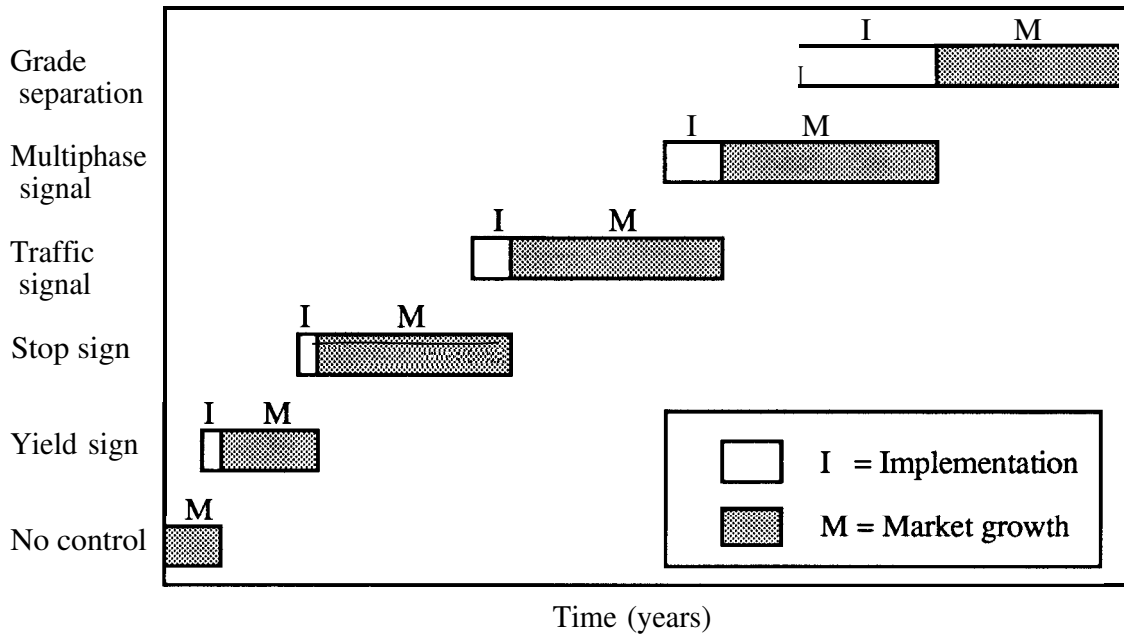

Figure 3.18. Bar chart (Gantt chart) for intersection control.

neglected, with the result that the appropriate technology is not deployed at the location until after the market has grown beyond the limits of the previous technology, because of the time required to implement the replacement.

As stated in Chapter 1, an example of the current design approach is the treatment of control at a highway intersection. If the traffic flow is below some minimum level, then control of the intersection is not necessary. As the flow grows a yield sign could be introduced, followed by stop signs for one or more directions. At higher flows simple traffic signals will be installed, followed eventually by multiphase signals with turn lanes. If the traffic flows get large enough, grade-separation will be considered. This design path was found by a process of trial and error which occurred over a period of many years.

The treatment of highway intersections provides a simple example of an activity network representation of the design process. Figure 3.18 is a bar chart, or Gantt chart, representing how the control technologies might be deployed at a particular intersection. As mentioned, the control proceeds as follows: no control, yield sign, stop sign, simple traffic signal, multiphase traffic signal, and finally, a grade-separated intersection. A basic

arrow diagram for this situation would not be very interesting because the relationships between these technologies are weak, thus it is not shown. Figure 3.19 is a SPAN diagram for this situation which takes into account the relative time required to implement each activity and the market range of each technology (numbers are not shown). This diagram shows how these technologies would be implemented with a particular projected market growth (which is shown in the figure).

This example is easy to represent with a SPAN diagram because the development phase activities have already been completed and do not have to be repeated. Furthermore, the dependencies of each technology on the others are very weak because they have already been developed. The time and cost required to implement each technology are well known. The market range calculations for each technology have already been performed and the results are the traffic flow ranges for the individual technologies. Although the time for the flow to grow through the market range depends on the particular location, procedures for estimating growth of traffic volumes are well established.

The activity network design approach uses the current “phased” design approach as a point of departure, but extensions to this approach are required. When designing alternative transportation systems the design path must be identified without the benefit of years of experience. A further complication is the fact that development of technologies often depends on development of previous technologies. The activity network approach to design will not give an optimum design path nor predict what the design will ultimately look like, because the network and associated parameters will be constantly changing as new knowledge and experience are acquired. However, the activity network approach will help facility designers decide how to allocate resources by showing the relationships between the various technologies, and it will help suppliers decide what to put where and when. The current design approach might be sufficient for mature systems but not for alternative systems with many new and/or potential technologies to be considered (as is the case in the lean vehicle situation). The activity network design approach is intended to get a

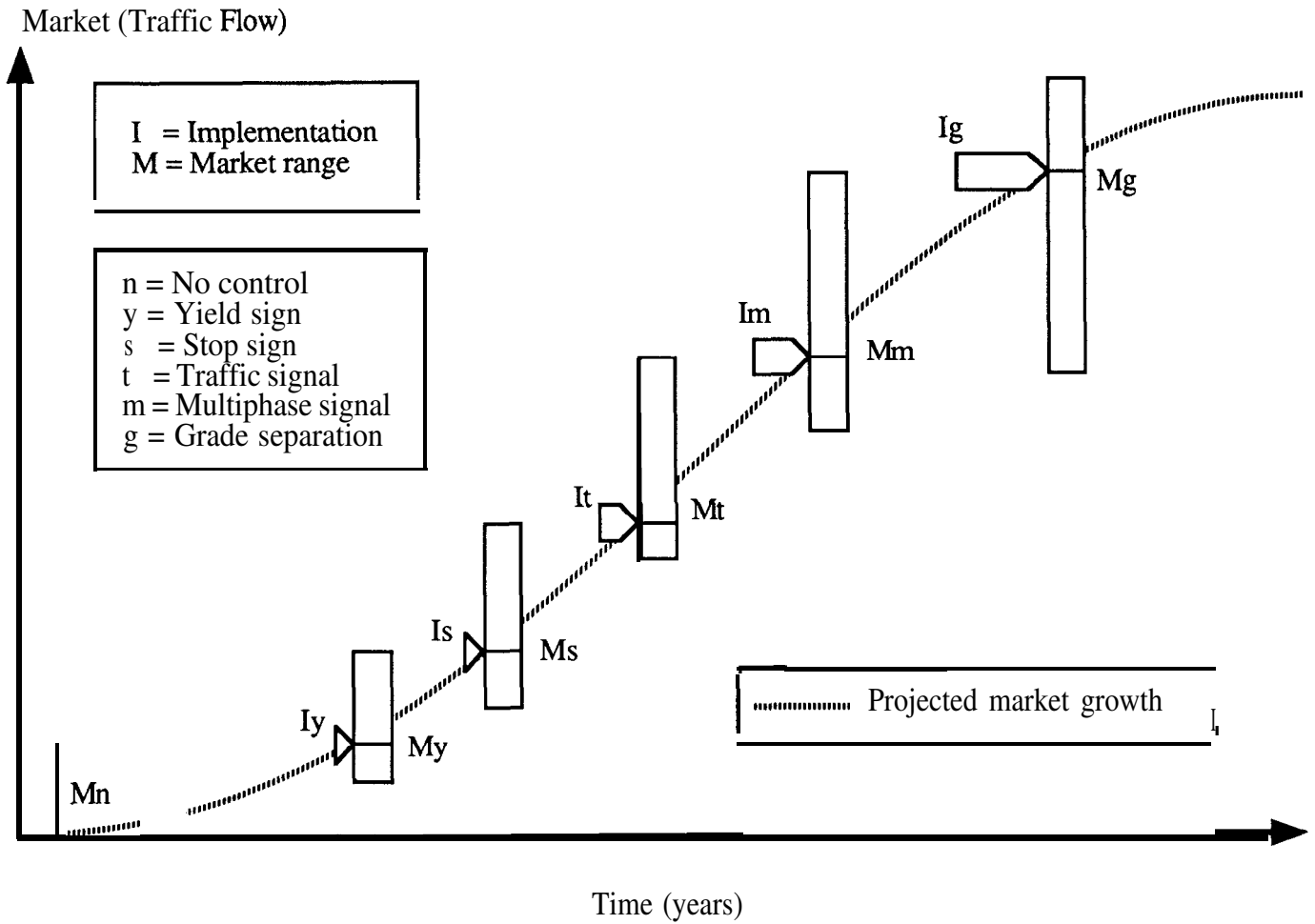

Figure 3.19. SPAN diagram for intersection control.

more substantial change than would occur with the current design approach by providing information that triggers the decisions to change technologies.

3.5. Method Distinction

The activity network design approach outlined in this research can be distinguished from previous activity network techniques in a number of ways. The networks used in this approach are fairly simple (not too many activities) which allows a graphical presentation of results using two-dimensional SPAN diagrams (the four letter acronym follows the activity network tradition). Sub-networks showing minor activities for each major activity could be quite complicated, but they would be standard activity networks for which a host of analysis techniques already exist. Time-scaled activity networks are fairly common, but the addition of a market dimension to the diagrams opens up a whole set of new applications. Precedence diagrams have been selected instead of arrow diagrams because they eliminate dummy activities and allow a clearer representation with two dimensions.

The activity networks used in this approach have multiple start and end points, thus there is a “critical path” for each technology represented in the diagrams. There is no single critical path from start to end as there is in most typical “project” applications of activity networks. Activity networks are used here as part of a design method; thus, the networks will change as time progresses and the market grows. This is to be desired. The project “end date” is not slipping because there is no end to the project; the process is meant to be continuous. Parts of the activity networks, implementation and market growth activities without development activities, are useful even after the first application of each technology. These partial networks would be used as in the intersection control example described in Chapter 3. The method is interactive and iterative because estimates of time, costs, and resources can be updated based on experience.

The activity network approach allows simultaneous assessment of several technologies; not only individually, but also in combination. As such, the approach

provides a method of risk avoidance by comparing several alternatives both numerically and graphically. The approach is used as both a planning and evaluation tool that leads eventually to new system designs. There is no optimum path because choices and calculations change as time progresses. Calculations change because the reference point is the current situation. The method is intended to guide decisions based on current knowledge and situations.

3.6. Applicability to Other Transportation Systems

The activity network design approach should also be useful for designing any of the other alternative transportation systems listed in Chapter 1 (truck highways, intelligent vehicle/highway systems, high-speed rail . ..). Let us first consider the high-speed rail situation to see how the approach might be used.

If a decision has already been made to put a maglev system, for instance, into a specific corridor, then it is too late to use the activity network approach; it will not tell you how to “design” such a system. The activity network approach might be somewhat useful if you are considering an order of magnitude upgrade of a corridor and want to decide between various alternatives (various steel-wheel on rail technologies, conventional maglev, high or low temperature superconducting maglev, etc.). However, other evaluation strategies would probably be better suited for this application.

The activity network approach would be much more useful if you were considering a series of incremental upgrades to a corridor or corridors. For a steel-wheel on rail corridor these upgrades might include such things as: continuously welded rail, concrete ties, segment realignment, grade-crossing elimination, new locomotives, tilt-body cars, and route electrification (mostly existing technologies but perhaps a few new ones as well). The activity network approach would also be useful for planning and designing a national or regional high-speed rail system which would be deployed in a number of corridors over

time with changes in technology along the way. The Trains à Grande Vitesse (TGV) system in France is a perfect example of this type of system.

For the automobile/truck highway system, the activity network approach could also be applied in two ways. The first application is within the realm of traditional highway design. Lately there seems to be a return to the pre-interstate period of trial and error involving both existing technologies such as reversible lanes and high-occupancy vehicle (HOV) lanes, and new technologies such as “urban interchanges” (a design which is an outgrowth of diamond interchanges). A related but slightly different situation is the design of intelligent vehicle/highway systems (IVHS). IVHS includes the above mentioned existing technologies along with a set of new technologies, many of which have not yet been fully developed. These new technologies include the following: vehicle identification, navigation, route guidance, driver information, traffic control, road pricing, and lateral and longitudinal guidance. The goal of IVHS is to eventually transform the existing vehicle/highway system into some alternative system (perhaps even automated highways, though not necessarily).

An extension of the activity network approach would be to investigate its use for designing systems with characteristics similar to transportation systems, such as energy or communication systems. Some of those applications might actually introduce decreasing demand situations for certain transportation systems. Examples include substitution of communication for transportation, and energy conservation leading to decreased transportation of raw materials (oil, coal, natural gas) or people.

4. CASE STUDY: LEAN VEHICLE PARKING FACILITIES

Now that the design approach and the transportation system to be designed have been identified, it is necessary to explore the range of possibilities: the divergence step. The following is a list of potential technologies which could someday become parts of a system designed for lean vehicles:

- A. Designated parking spaces on streets and in lots and garages.
- B. Separate lanes on arterials or highways (shared with motorcycles).
- C. Lanes shared with conventional automobiles and trucks (on a 2 to 1 basis).
- D. Prefabricated elevated structures on arterials or highways.
- E. Intersection flyovers on urban/suburban arterials.
- F. Reversible lanes (which flow in commute direction only).
- G. Convertible lanes (for use during commute hours only).
- H. Outrigger lanes on bridges or viaducts.
- I. Stacked lanes in tunnels (allowed by low vehicle heights).
- J. Bypasses around or over tunnels (with steeper grades).
- K. Lanes on shoulders at bottlenecks.
- L. Lanes in new rights-of-way (electric transmission lines, etc.).

This list is by no means complete, it merely represents some of the potential technologies which can be envisioned today (a more thorough classification of special lane types is presented in Chapter 5). Other potential technologies would present themselves over time as the market for lean vehicles grows.

The next step in the lean vehicle design process is to decide what to do with all of these potential technologies. Convergence is not really necessary in the formal sense because it will be accomplished over time by the interaction of the design with market forces. What is necessary is to determine how these various technologies are related to one another. This can be accomplished by drawing the activity networks with dependencies and performing the required calculations (outlined in the Chapter 3), which include

estimation of the time required to develop and implement each technology and benefit/cost calculations to define the acceptable range of each technology. This study does not attempt to define all possible activity networks or perform all the associated calculations, but it does outline the networks for a few example families of technologies and shows how the appropriate calculations would be performed.

This study explores situations like the treatment of intersections to accommodate lean vehicles. That situation is much more complicated than the treatment of traditional highway intersections discussed in Chapter 3, because the design path must be identified without the benefit of years of experience. It is also more complicated than the parking situation discussed in this chapter, because there are many more potential technologies involved and the relationships between all of those technologies must be considered.

An example of a technology for lean vehicles which could be used at intersections is the flyover. Lean vehicle flyovers at intersections would require a certain local market level to be cost effective. Conversely, when the market level reaches a certain point the flyover itself will become congested and it will no longer provide any additional benefit for new users and will have to be modified or replaced with another technology. The cost of implementing a flyover should be easy to calculate based on comparison with existing highway facilities. The time to build a flyover could be long if it is one of only a few flyovers (in which case additional resources could be applied to decrease the time), or it could be short if it is one of many flyovers and prefabrication is utilized (in which case resources are dedicated to the production process). Flyovers might depend on some predecessor technologies, such as electronically controlled gates to restrict access to small and light vehicles only.

The broad goal of this study is to construct activity networks for the design of a system of facilities for lean vehicles. These networks will include a variety of technologies in several families, such as the road modifications mentioned above and the parking modifications discussed below. In the interest of clarity, the modification of parking

facilities will be discussed first because the approach is new and there are fewer parking options to consider.

4.1. Parking Modification Concepts

Lean vehicles will need to park as well as operate on roads. If lean vehicles begin to appear in the vehicle fleet, existing parking facilities could be modified to accommodate the smaller vehicles and thus provide parking for more vehicles in a given amount of space. Lean vehicles could certainly park in existing automobile parking spaces, but any cost reductions must come from modification of existing facilities or creation of new spaces.

Modifications could involve creating new spaces for lean vehicles in small dead areas that are not currently useful, letting two lean vehicles park in one existing conventional space, or restriping a parking area with spaces appropriate for lean vehicles. Excess parking demand is assumed, otherwise modifications are unnecessary and lean vehicles can use existing spaces as they are currently configured. Eventually, new parking facilities designed specifically for lean vehicles could replace existing facilities, resulting in significant cost reductions per space and freeing up valuable land area. These four lean vehicle parking concepts, or technologies, can be designated as follows (the words “concept” and “technology” will be used interchangeably throughout the study):

1. Dead spaces concept,
2. Two-in-one concept,
3. **Restripe** concept, and
4. New design concept.

Using the Lean Machine as an example, these four concepts will now be explored. The following sections discuss each parking concept for surface lots, garages, and streets, since each situation has slightly different requirements. The parking lot situation will be discussed first since it is the least complicated; then further considerations particular to parking garages and street parking will be discussed.

4.1.1. Parking Lots

Despite the large area required for each standard parking space, surface parking lots remain common even in many central business districts.

Dead Spaces Concept

Perhaps the easiest way to provide extra spaces would be to use “dead” areas which are too small to accommodate standard vehicles, but large enough for lean vehicles. These dead areas typically occur at the ends of aisles, near entrances and exits, and near obstructions. The upper market limit of this concept is determined by the availability of areas suitable for dead spaces.

Two-in-one Concept

With the anticipated small dimensions of lean vehicles it might be possible to gain even more parking capacity by parking two of them in a single existing parking space, as shown in Figure 4.1, using Lean Machines as an example. Automobiles would still be able to park in these spaces if necessary. Extra striping would probably be required to guide the lean vehicles into the proper location within the space. Two vehicles with the projected dimensions of the Lean Machine would probably have to be staggered within existing standard or compact spaces in order to provide room for entering and exiting the vehicles. Testing would be required to determine whether the head-in or tail-in direction is preferable for each vehicle, depending on the door configuration. The upper market limit is reached when all parking spaces are converted to the two-in-one concept.

Restripe Concept

For an even better use of space, a portion of an existing lot could be restriped to accommodate lean vehicles only. This would involve developing new patterns for narrower aisles as well as smaller spaces. Figure 4.2 shows a pattern which takes advantage of the narrow nose of the Lean Machine by staggering the spaces. This design allows the parking of 3.5 Lean Machines in the area (including aisle area) required for one

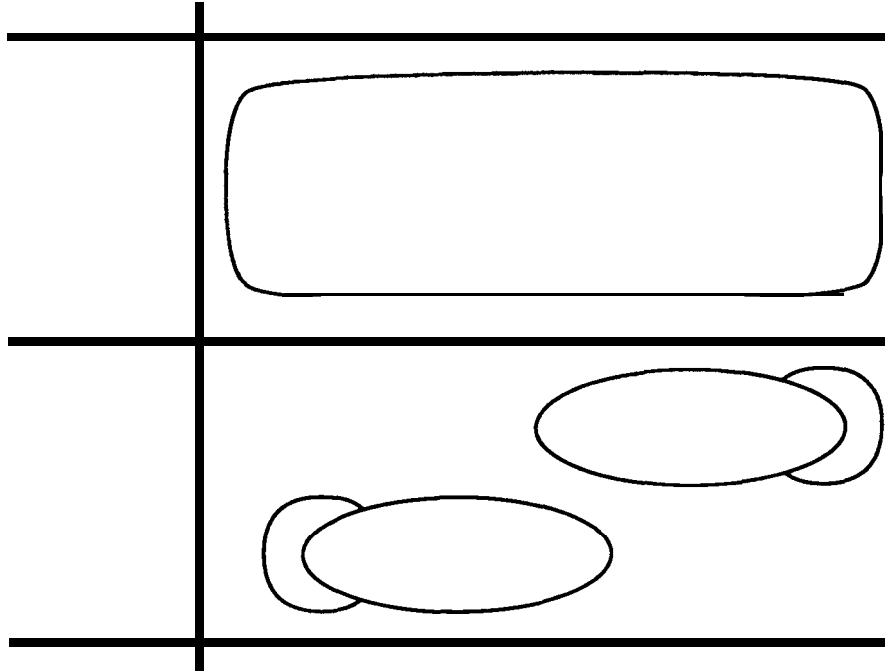

Figure 4.1. Two-in-one concept for parking lots and garages.

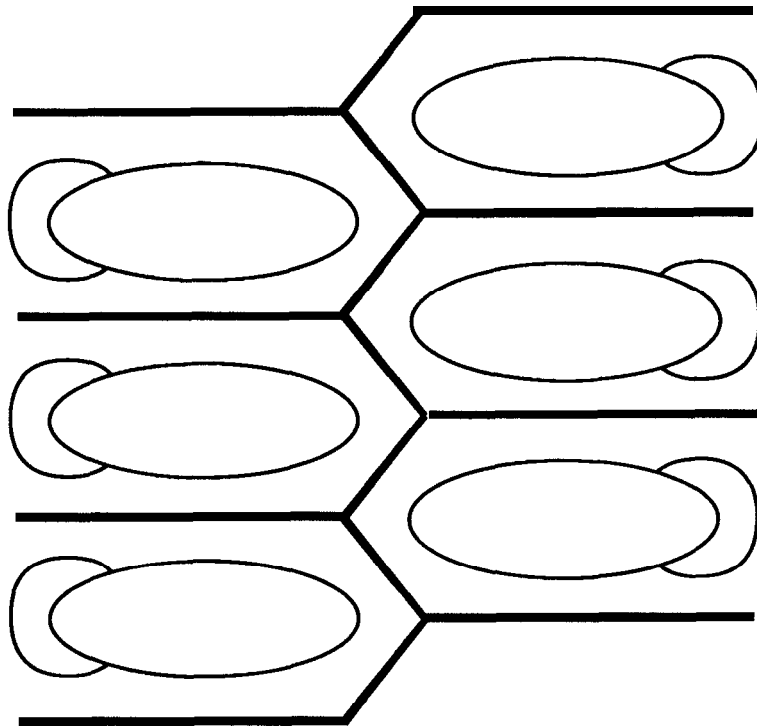

Figure 4.2. Restripe concept for parking lots and garages.

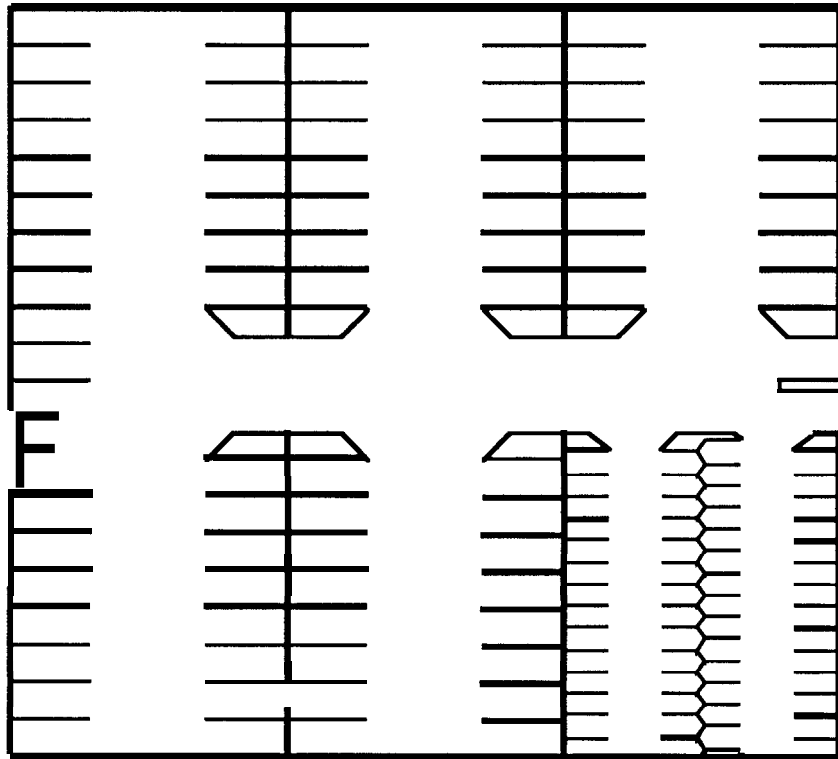

Figure 4.3. Parking lot with section restriped for lean vehicles.

standard car [Garrison and Pitstick, 1990a, p. 27]. With this design one bay of standard spaces could be replaced with two bays of Lean Machine spaces (as in Figure 4.3), or alternatively, two bays of compact spaces could be replaced with three bays of Lean Machine spaces. The upper market limit is reached when the entire parking area is restriped.

New Design Concept

As the number of lean vehicles grows, there might be situations where it would be advantageous to design and build new parking lots (or additions to existing ones), or to redesign and rebuild existing lots, specifically for lean vehicles. The resulting space and aisle patterns could be different than the restripe patterns because the new design concept

would not be constrained by existing patterns as is the case in restriping. The new design concept could take advantage of the lower weight of lean vehicles, which would reduce pavement requirements, in addition to their smaller dimensions. Thinner pavement would require limiting access to the new lot, which could be accomplished, for example, with narrow gates that accommodate Lean Machines and motorcycles but not cars and trucks. The upper limit for the new design concept is determined by the availability of space (land) to locate new lots.

4.1.2. Parking Garages

Although parking garages use less land area per space, the cost per space is usually several times higher than for a surface lot due to the massive structure that is required for each floor. Again, each standard space requires a large floor area which could be significantly reduced for lean vehicles. Parking garages add further complications and opportunities for lean vehicles due to ramps, columns, and structural considerations.

Ramps and columns tend to create even more dead areas (compared to lots) which can be converted to dead spaces for lean vehicles. The two-in-one concept for parking garages is basically the same as for parking lots and the ideas behind the **restripe** concept for garages are the same as for lots, but the presence and location of columns and ramps dictate which space and aisle patterns will be feasible. As a result, the **restripe** patterns for garages could be different than for lots, but the area per space should be about the same.

A new parking garage designed for lean vehicles will have reduced structural requirements for the floors and ramps in addition to the reduced size requirements. The space and aisle patterns will have to be designed in conjunction with the structure because the column and ramp locations influence the feasibility of patterns. Restricting access to lean vehicles only is even more important for garages than for surface lots. In this case, gates controlled by weigh-in-motion technologies might be used, but narrow gates would probably be sufficient.

4.1.3. Street Parking

Lean vehicle street parking shares many characteristics with the parking lot situation, but there are some important differences. First, the focus is linear for street parking as opposed to rectangular for parking lots. Second, the spaces in parking lots are primarily perpendicular to the direction of vehicle movement (or angled) with only a few parallel spaces. For street parking, spaces which are parallel to the street are more common than perpendicular or angled spaces.

The two-in-one concept for perpendicular or angled street parking spaces is the same as for parking lots. For parallel street parking spaces, the two-in-one concept is also possible, but the two Lean Machines would be parked at an angle as shown in Figure 4.4. An additional stripe across the middle of the space would probably be necessary to keep the vehicles in the proper location within the space. This type of arrangement would also be used for the few parallel spaces in parking lots and garages. Parking of Lean Machines at an angle in parallel spaces would allow easier entry and exit and use less curb space, but no more than two Lean Machines could fit into a standard space without restriping.

The **restripe** concept for street parking would be applied to a linear section of the street. By restriping a group of parallel spaces, three Lean Machines parked at an angle could fit in the same curb space as a single car, as shown in Figure 4.4.

Restriping of perpendicular or angled parking spaces would only allow 1.7 Lean Machines to fit into the curb space of a single car [Garrison and Pitstick, 1990b, p. 22]. This is significantly less than the gain from restriping a section of a parking lot because the aisles are not included in the street parking situation. However, restriping a group of perpendicular or angled spaces into parallel standard spaces and/or perpendicular Lean Machine spaces could provide enough room for an extra travel lane for Lean Machines, as shown in Figure 4.5. This could occur without a loss in the total number of spaces if about 80% of the spaces are dedicated to Lean Machines [Garrison and Pitstick, 1990b, p. 22].

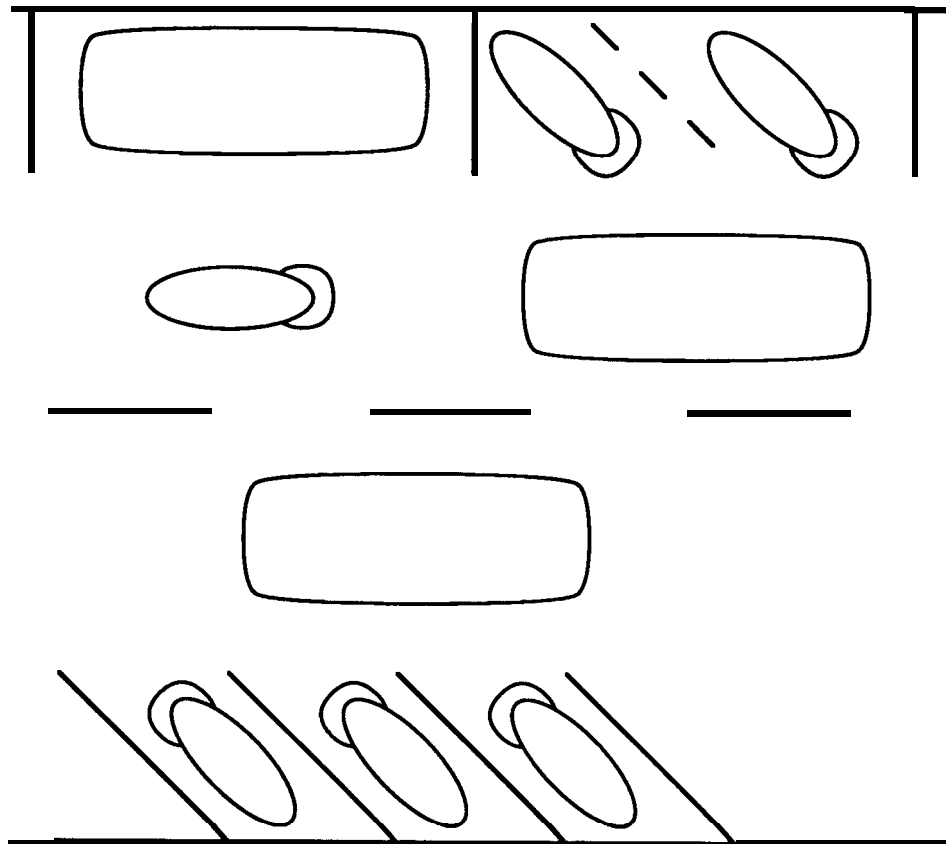

Figure 4.4. Two-in-one and restripe concepts for parallel street parking.

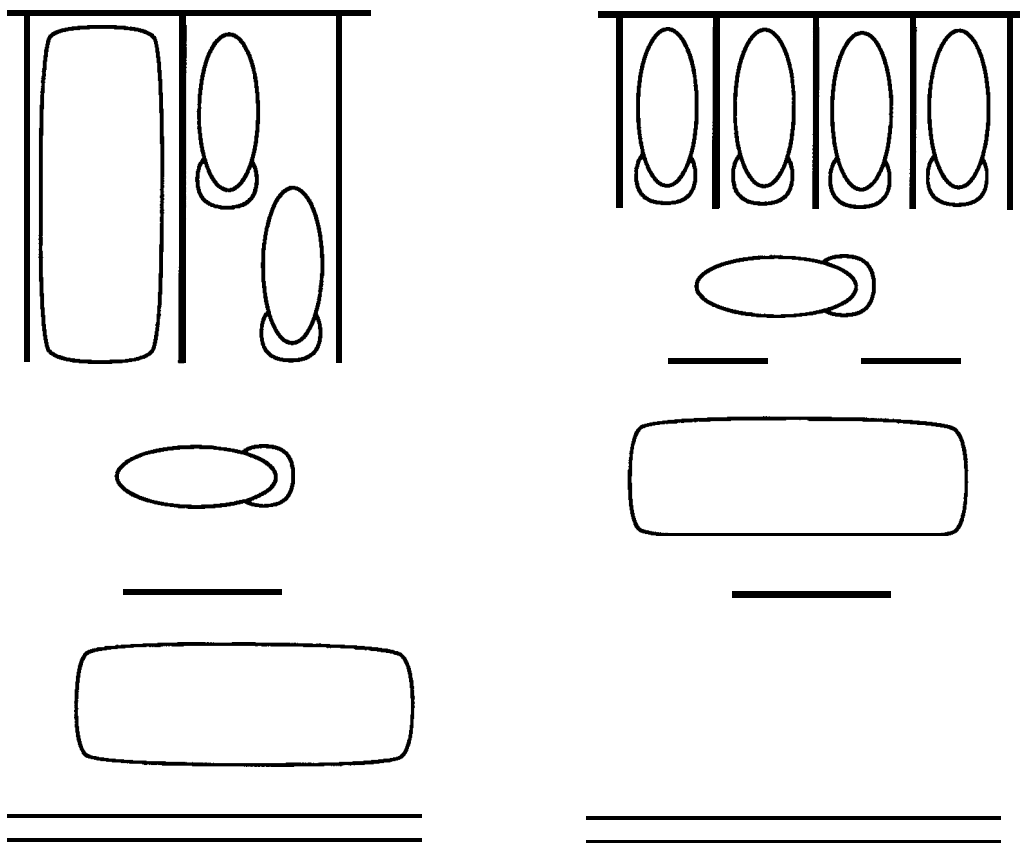

Figure 4.5. Two-in-one and **restripe** concepts for perpendicular street parking.

New or redesigned streets sized specifically for lean vehicles might eventually be built. These streets need not be limited to lean vehicles only, but could have a limited number of lanes which would accommodate cars and trucks. The result could be a street which is narrower than a conventional street with the same capacity. The extra space could be used for more parking, wider sidewalks, wider lawns, or denser development.

4.2. Activity Networks

Figure 4.6 is an activity network representation of some of the modifications which could encourage and accommodate parking of lean vehicles in lots and garages. It is not the only activity network that could be drawn, nor does it include all possible modifications. However, it is a logical representation of the most likely concepts or “technologies.” It is in the form of a precedence diagram, with each box representing an activity (development, implementation, or market growth) associated with a particular technology. There could also be generic activities which apply to more than one technology (as will be shown in the activity networks for road facilities), but that is not the case for parking facilities. The arrows connecting the boxes represent precedence relationships; they show which activities must occur before which others. This diagram can be referred to as an “unscaled” activity network, since there is no attempt to represent any dimension (such as time, cost, or resources).

This activity network applies to both parking lots and parking garages because the technologies are the same for both situations. However, any calculations based on this diagram will be different because many of the activity parameters (time, cost, and resources) for parking lots are different than those for garages. Thus, the results and scaled activity networks for parking lots and garages will be presented separately.

Development of the dead space concept includes determining the minimum size and shape of lean vehicle parking spaces and access to those spaces. These depend on vehicle

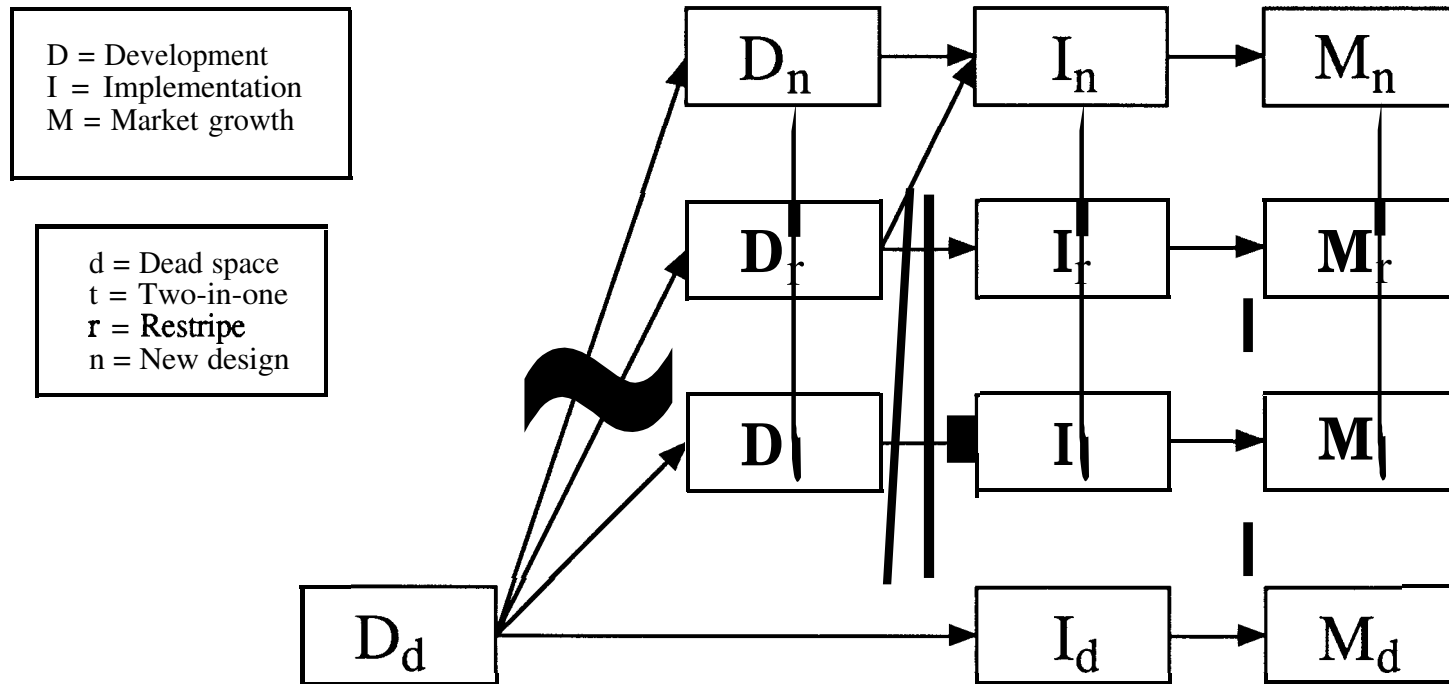

Figure 4.6. Parking lot and garage activity network.

dimensions, turning radius, and vehicle access and egress (i.e., door design). This is a basic development activity which must be completed before the development of any of the other technologies begins, as shown by the arrows in the diagram. Implementation includes removing existing striping (if any), adding striping for the lean vehicle, and adding a sign which identifies the space (if necessary).

Development of the two-in-one concept includes determining the appropriate arrangement of lean vehicles within the space and the required striping pattern. Implementation includes adding the necessary striping and appropriate identification.

Development of the **restripe** concept includes determining appropriate striping patterns for aisles and spaces. This **restripe** development activity is also necessary before implementation of new designs (discussed below), as shown by the precedence arrow in the diagram. Implementation of the **restripe** concept includes identification of appropriate areas to restripe, removing existing striping, and adding new striping and identification for lean vehicles.

Development of the new design concept includes pavement and/or structural considerations as well as providing access and egress for lean vehicles only. Pattern development is considered as part of the **restripe** development activity. Implementation includes site specific design and planning and construction of the facility.

The activity network for modifications to street parking is shown in Figure 4.7. This diagram is similar to Figure 4.6 except for the activities in the large box which represent part of the arterial activity network. The new design concept for street parking involves a new street, which encompasses other considerations besides parking. Similarly, the restriping of street parking could lead to the creation of a new lane. Therefore, calculations for new streets and new lanes are not included as part of the parking situation. The street parking activity network applies to both parallel and perpendicular (or angled) spaces, but again, the calculations for those two situations are different and the results will be presented separately.

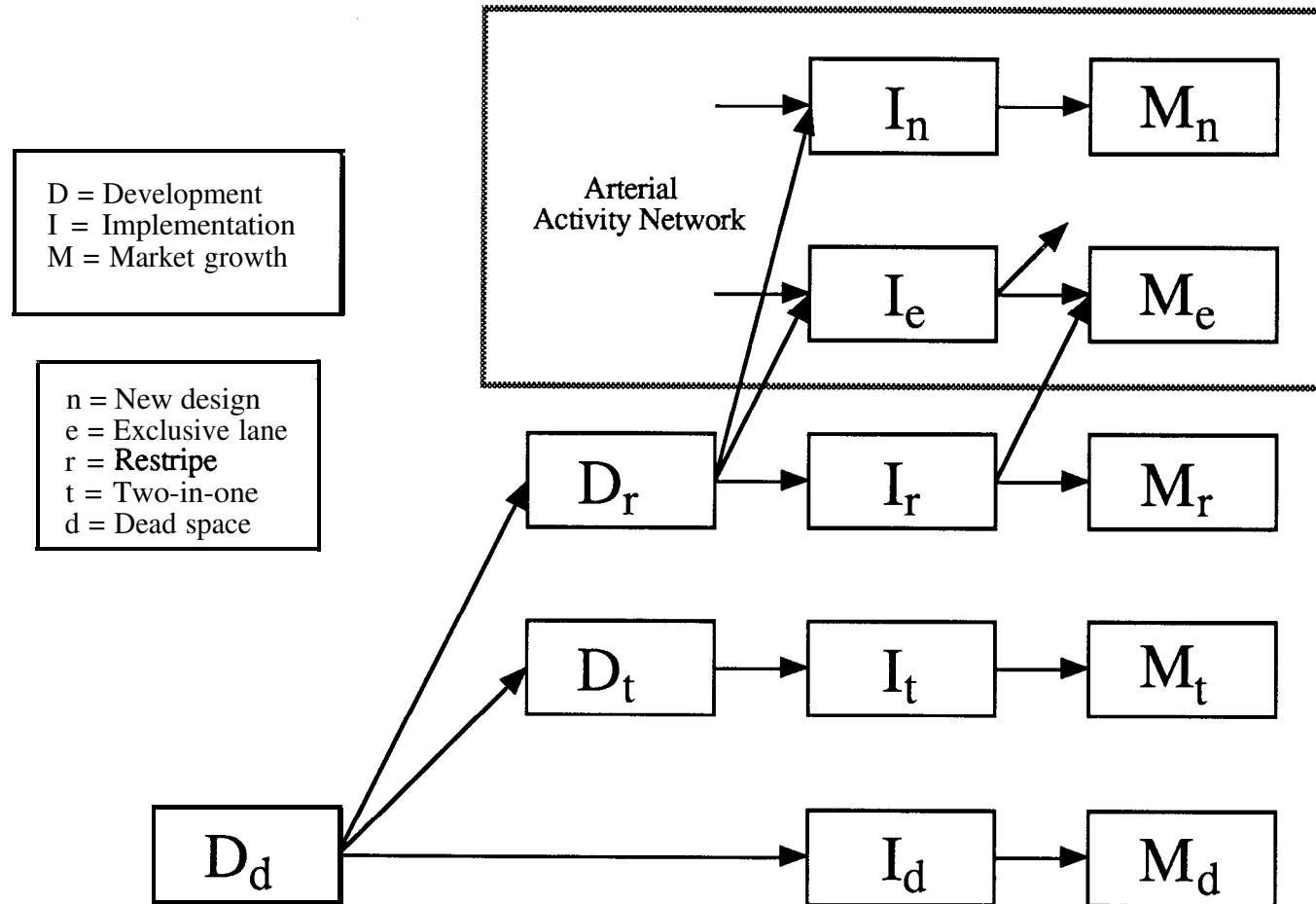

Figure 4.7. Street parking activity network.

4.3. Market Range Calculations

Although there are many in favor of profit parking facilities, especially in central business districts, the user of a parking space generally does not pay for the full cost of providing that space, and often pays nothing at all. For that reason, the market range calculations will be based on the perspective of the provider of the parking facility, which could be either public or private. Therefore, the cost of providing a parking space for a lean vehicle will be compared to the alternative of creating an additional automobile parking space. It is assumed that there is a shortage of parking spaces, otherwise the lean vehicles should just park in existing spaces without modification. In cases where automobile spaces are removed in order to create lean vehicle spaces (such as in the restriping concept), the value of the spaces lost is also considered.

For parking modifications the benefit is defined as

$$B_x(m) = (m - N_x^R) V \quad (4.1)$$

where N_x^R is the number of conventional spaces removed for each application of concept x , and V is the value of an additional space. The market level, m , is the actual number of lean vehicles using the facility, which is not necessarily the same as the number of lean vehicle parking spaces available.

The net gain in spaces for each application of concept x , N_x^G , is

$$N_x^G = N_x^A - N_x^R \quad (4.2)$$

where N_x^A is the number of spaces added by each application of concept x . Combining (4.1) and (4.2) gives the maximum benefit provided by each application.

$$B_x^{\max} = (N_x^A - N_x^R) V = N_x^G V \quad (4.3)$$

The activity time and cost estimates can be used to define the appropriate market range for each concept or technology. The market range is defined by lower and upper limits. The lower limit represents a break-even point between the implementation and

market growth costs (if any) and the benefit (value) of providing the extra spaces. The upper limit represents either another break-even point or, as in the case of parking modifications, a physical limit.

The implementation cost includes the cost to remove conventional spaces and the cost to add lean spaces. The additional operating and maintenance costs for the parking modifications, C^M_x , are assumed to be negligible.

$$C^M_x \cong 0 \quad (4.4)$$

Combining (3.5), (3.6), (4.1), and (4.4) we can obtain the lower market limit for parking modifications (strategy zero), L_x^0 ,

$$L_x^0 = N_x^R + \text{Integer} \left[\frac{1}{V} \sum_y^x \mathbf{1} \right] \quad (4.5)$$

where the value in brackets is rounded up to the next integer. The upper market limits for strategy zero, U_x^0 , are determined by physical limits dictated by the geometry and size of the facility. For example, only a limited number of useable spaces can be created from dead areas in a given lot or garage.

The first application limit is another break-even point which considers development activity costs in addition to implementation and market growth costs. Combining (3.5), (3.22), (3.13), (4.1), and (4.4) we can obtain the first application limit for parking modifications (strategy zero), F_x^0 ,

$$F_x^0 = N_x^0 N_x^R + \text{Integer} \left[\frac{1}{V} \sum_z^x C^D_z + \frac{N_x^0}{V} \sum_y^x C^I_y \right] \quad (4.6)$$

where N_x^0 is from (3.5), (3.11), (3.12), (4.3), and (4.4).

$$N_x^0 = \text{Integer} \left[\frac{\sum_z^x C^D_z}{N_x^G V - \sum_y^x C^I_y} \right] \quad (4.7)$$

Restripe and new design implementation costs are situation specific. For parking lots the existing facility is assumed to accommodate 100 automobiles in the arrangement shown in Figure 4.3. That figure shows how one section of the lot (16 auto spaces) would be restriped for lean vehicles (56 lean spaces). Since a one-aisle bay is being replaced by a two-aisle bay, it would not be possible or practical to **restripe** a smaller area. The figure also shows where the 10 dead spaces (before restriping) could be located at the ends of the aisles. For parking garages the existing facility is assumed to hold 100 automobiles on three levels, with each level arranged similar to one-third of the parking lot shown in Figure 4.3. The existence of columns and ramps in the garage should provide space for about 5 additional dead spaces (giving a total of 15). For the new design concept, calculations are based on an addition with one-third the floor space of the existing lot, which requires removal of two conventional parking spaces for access to the addition.

For street parking the reference situation is assumed to be one block long. With parallel parking, the block would accommodate about 20 automobiles and have enough room for about 4 dead spaces near comers or driveways. With perpendicular (or angled) parking, the block would accommodate about 50 automobiles and have enough room for only 2 dead spaces, since the automobile spaces are fairly narrow and use the curb space more efficiently than parallel spaces.

The number of spaces added and removed for each type of parking modification is given in Table 4.1, along with the net gain of spaces. The market range calculations are based on a one-time cost of \$2,000 for providing an automobile parking space in a surface lot and \$10,000 for a space in a garage (from Table 4.2). The value of an additional street parking space is assumed to be equal to the cost of providing the cheapest alternative, which in this case is a space in a surface lot (\$2,000). Unit costs for implementation and development are given in Tables 4.3 and 4.4, respectively. Annual maintenance costs are not considered for parking facility calculations.

Table 4.1 Number of Spaces Added and Removed for Parking Modifications

Technology (x)	Number of Parking Spaces (per lot, garage, or block)		
	Removed N_x^R	Added N_x^A	Net Gain N_x^G
<u>Parking lots</u>			
Dead spaces (d)	0	1	1
Two-in-one (t)	1	2	1
Restripe (r)	16	56	40
New design (n)	2	144	142
<u>Parking garages</u>			
Dead spaces (d)	0	1	1
Two-in-one (t)	1	2	1
Restripe (r)	16	56	40
New design (n)	2	144	142
<u>Parallel street parking</u>			
Dead spaces (d)	0	1	1
Two-in-one (t)	1	2	1
Restripe (r)	2	6	4
<u>Pemendicular street parking</u>			
Dead spaces (d)	0	1	1
Two-in-one (t)	1	2	1
Restripe (r)	50	85	35

Table 4.2 Estimated Value of an Additional Parking Space

Location	1982 Cost Estimate ^a	1990 Cost Estimate
Surface lot	\$1,500	\$2,000
Above ground garage	\$7,500	\$10,000
Below ground garage	\$11,200	\$15,000

^a Source: **Whitlock** [1982, p. 21]. The most recent parking cost estimates and dimensions can be found in **Weant** and Levinson [1990].

Table 4.3 Unit Cost Estimates for Parking Modifications

Description	1978 Cost Estimate ^a	1990 Cost Estimate
Stripe removal (6" thermoplastic)	\$1.50/ft	\$2.00/ft
Stripe addition (6" thermoplastic)	\$0.60/ft	\$0.80/ft
Sign installation	\$75 each	\$100 each

^a Source: Edwards and Kelcey [1978, p. 5-25].

Table 4.4 Unit Cost Estimate for Parking Development

Component	Cost (per month)
1 Senior engineer	\$5,000
1 Junior engineer	\$3,000
2 "Workers" @\$3,000/mo	<u>\$6,000</u>
Total Labor	<u>\$14,000</u>
Equipment	\$4,000
Test site	\$10,000
Materials	<u>\$2,000</u>
Total Capital	<u>\$16,000</u>
Total Labor and Capital	<u>\$30,000</u>

The time and cost estimates for the development and implementation activities are summarized in Table 4.5 for the various parking modifications (see Appendix C for a sample cost estimate). The activity time estimates follow the procedure of the critical path method which assumes that unlimited resources are available to complete activities on the critical path. Naturally, any activity could take considerably longer if resources are limited or if administrative or regulatory obstacles are encountered. The minimum development time is expected to be on the order of one month, and the minimum implementation time is expected to be about one-half of a week. Some activities could be physically implemented in a few hours, but the work would require additional time to plan, arrange manpower and equipment, allow for drying of painted stripes, etc. The minimum implementation time for street parking modifications is expected to be about one week due to the additional planning and procedures made necessary by the adjacent street.

The resulting market ranges for the parking modifications are summarized in Table 4.6 for Strategy 0 (see Appendix C for sample calculations). Strategy 0 refers to the fact that these calculations were performed for each technology independently, without considering other technologies which might be implemented before or after the technology in question. Another strategy will be discussed later which considers a particular order of implementation with technologies existing in conjunction with or replacing other technologies. The first application limits shown in the table assume that all the development costs must be recovered in one location. However, in some situations the first application limits exceed the upper (physical) limits, in which case the remainder of the development costs would have to be recovered in other locations or by other technologies.

4.4. SPAN Diagrams

The activity time estimates in Table 4.5 and the market ranges in Table 4.6 are best represented in graphical form. Scaled precedence activity network (SPAN) diagrams for parking lots, parking garages, and parallel and perpendicular street parking are presented in

Table 4.5 Activity Time and Cost Parameters for Parking Modifications

Technology (x)	Development		Implementation	
	Time	Cost (\$)	Time	cost (\$) ^a
	T_x^D	C_x^D	T_x^I	C_x^I
<u>Parking lots</u>				
Dead spaces (d)	2 m	60,000	1/2 w	140
Two-in-one (t)	2 m	60,000	1/2 w	120
Restripe (r)	2 m	60,000	1 w	1,200
New design (n)	3 m	90,000	2 w	58,000
<u>Parking garages</u>				
Dead spaces (d)	2 m	60,000	1/2 w	140
Two-in-one (t)	2 m	60,000	1/2 w	120
Restripe (r)	2 m	60,000	1 w	1,200
New design (n)	4 m	120,000	4 w	144,000
<u>Parallel street parking</u>				
Dead spaces (d)	2 m	60,000	1 w	140
Two-in-one (t)	1 m	30,000	1 w	120
Restripe (r)	1 m	30,000	2 w	250
<u>Perpendicular street parking</u>				
Dead spaces (d)	2 m	60,000	1 w	140
Two-in-one (t)	2 m	60,000	1 w	120
Restripe (r)	1 m	30,000	3 w	2,400

^a Implementation costs are per application.

Table 4.6 Market Ranges for Parking Modifications - Strategy 0

Technology (x)	Lean Vehicles (per lot, garage, or block)		
	Lower limit L_x^0	Upper limit U_x^0	First application F_x^0
<u>Parking: lots</u>			
Dead spaces (d)	1	10	33
Two-in-one (t)	2	200	128
Restripe (r)	17	350	94
New design (n)	31	400	136
<u>Parking: garages</u>			
Dead spaces (d)	1	15	7
Two-in-one (t)	2	200	26
Restripe (r)	17	350	29
New design (n)	17	400	41
<u>Parallel street parking</u>			
Dead spaces (d)	1	4	33
Two-in-one (t)	2	40	96
Restripe (r)	3	64	71
<u>Pemendicular street parking</u>			
Dead spaces (d)	1	2	33
Two-in-one (t)	2	100	128
Restripe (r)	41	85	138

Figures 4.8 through 4.11, respectively. Diagrams are shown with development activities for Strategy 0. These diagrams are similar in structure except that the numbers are different for each situation. For street parking, the new design concept is not included in the calculations or the diagrams, as previously explained.

In some instances it is necessary to move the market range bar (and sometimes the implementation activity) to a later time in order to prevent overlap on the diagram. This artificial slack time is arbitrary and meaningless, but is done to prevent, for example, the two-in-one bar from being right on top of the **restripe** bar. The implementation of each technology is shown at the **first** application limit (indicated by a cross line) for the sake of clarity, but implementation could actually occur at any market level. For activities where the first application limit is above the upper (physical) limit the difference is shown as a darkly shaded area and implementation is shown at the upper limit. The first application limits for the parking garage situation are significantly lower than for the parking lot situation because of the higher value of an additional space (by a factor of five). As a result, none of the first application limits exceed the corresponding upper limit.

Obviously, dead spaces would be the first concept used in any strategy which combines several concepts since the cost is low and no automobiles need to be displaced. Also, the dead space concept can be developed (and implemented) before any of the other concepts. Unfortunately, the number of dead spaces is limited and the other concepts must be implemented eventually.

The choice between the two-in-one concept and the **restripe** concept is not quite so obvious. Although these concepts can be developed and implemented in about the same amount of time, the lower limit of the **restripe** concept is higher because an entire section must be restriped with the concurrent displacement of several automobiles. Therefore, it would be desirable and logical to use the two-in-one concept before restriping a section. The fact that the first application limit for the two-in-one concept is higher than for restriping should not alter this decision.

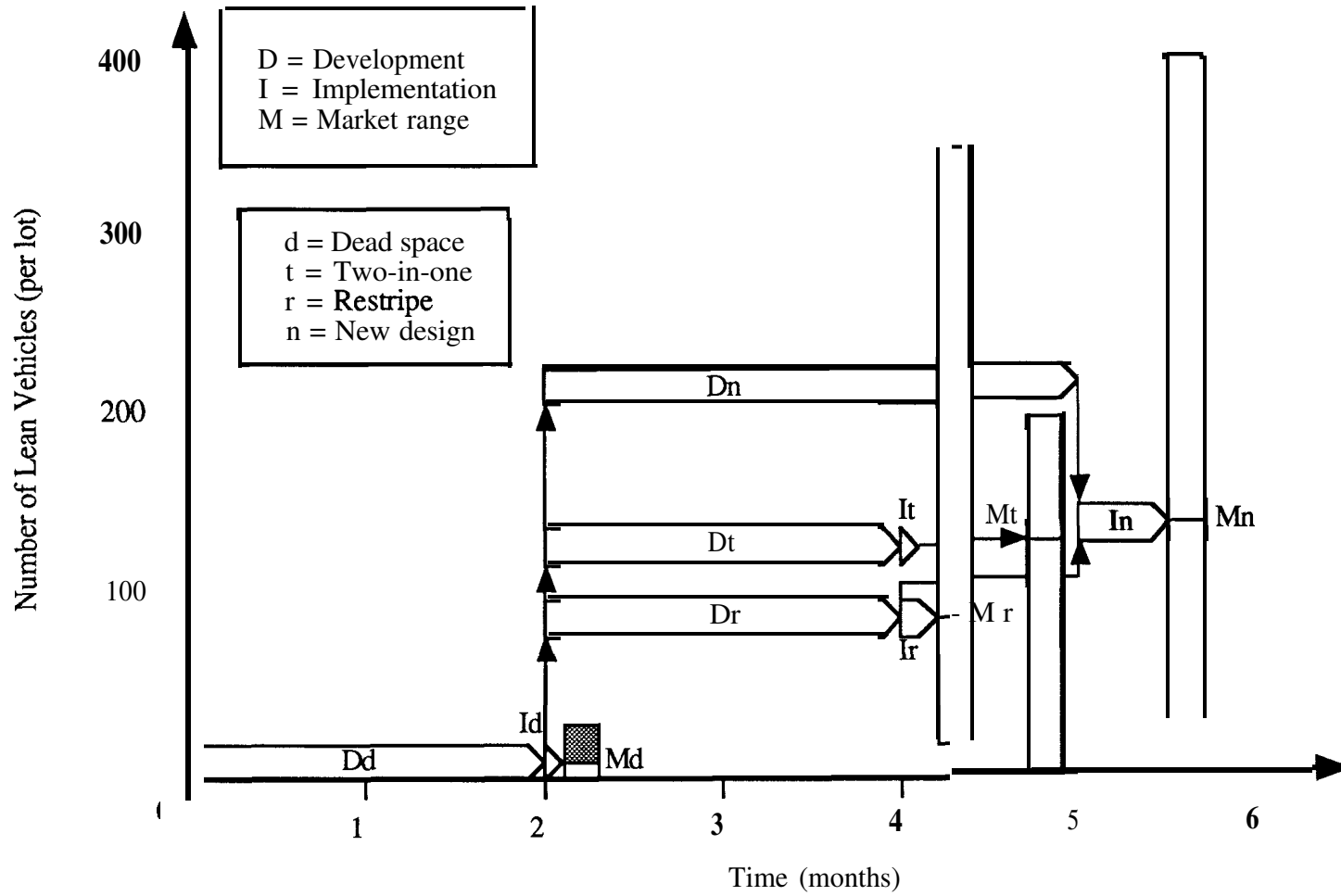

Figure 4.8. Parking lot SPAN diagram - Strategy 0.

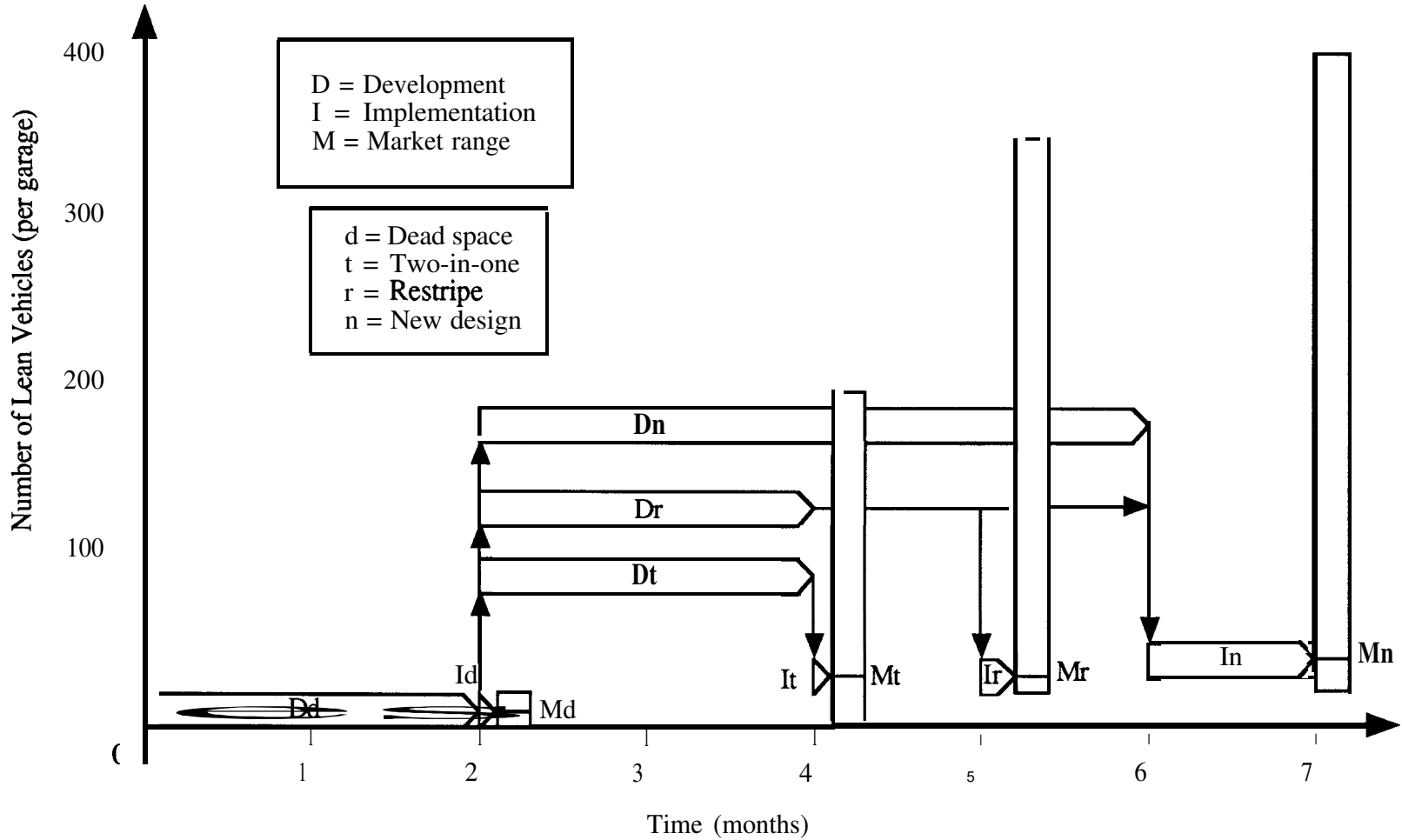

Figure 4.9. Parking garage SPAN diagram - Strategy 0.

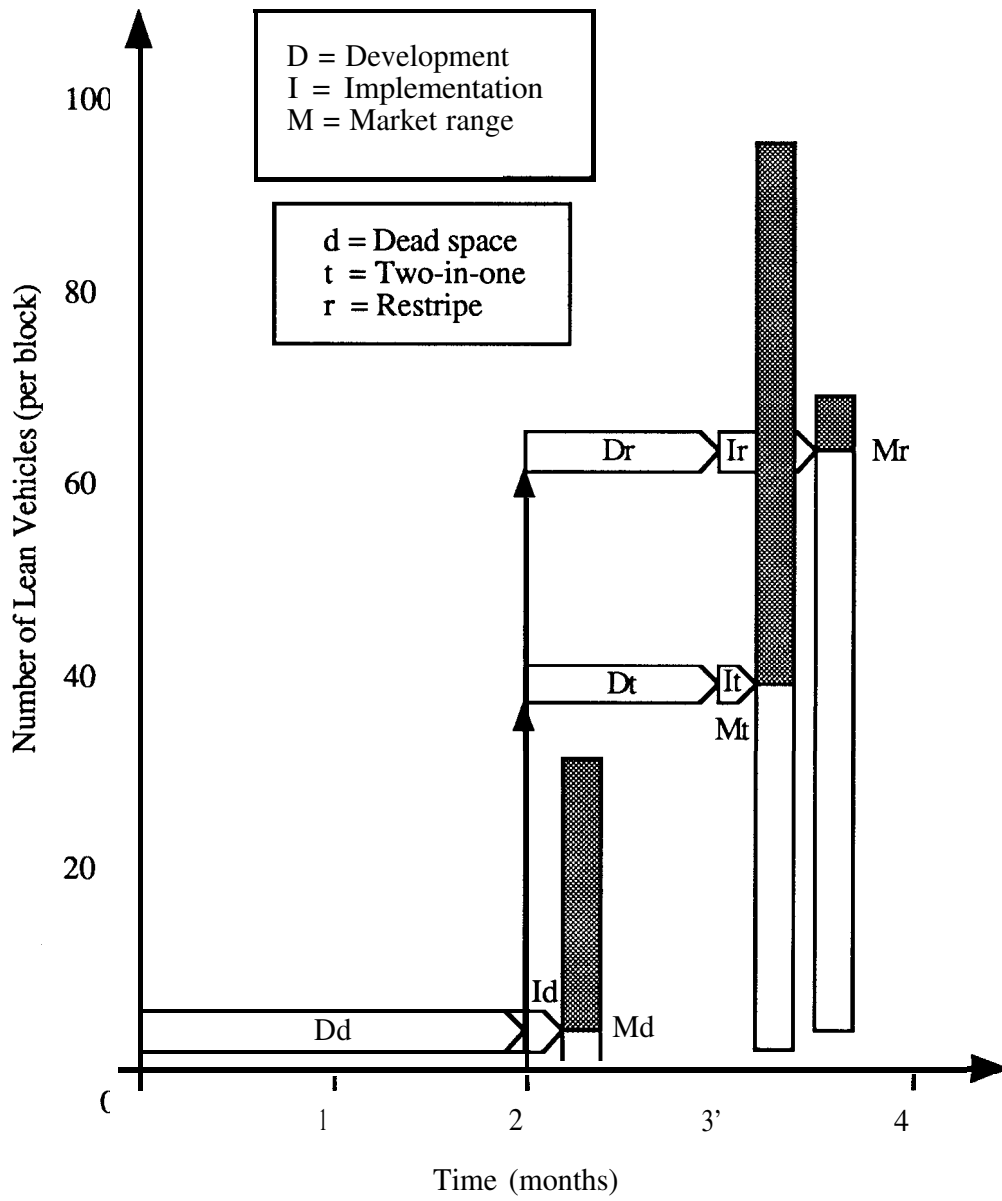

Figure 4.10. Parallel street parking SPAN diagram - Strategy 0.

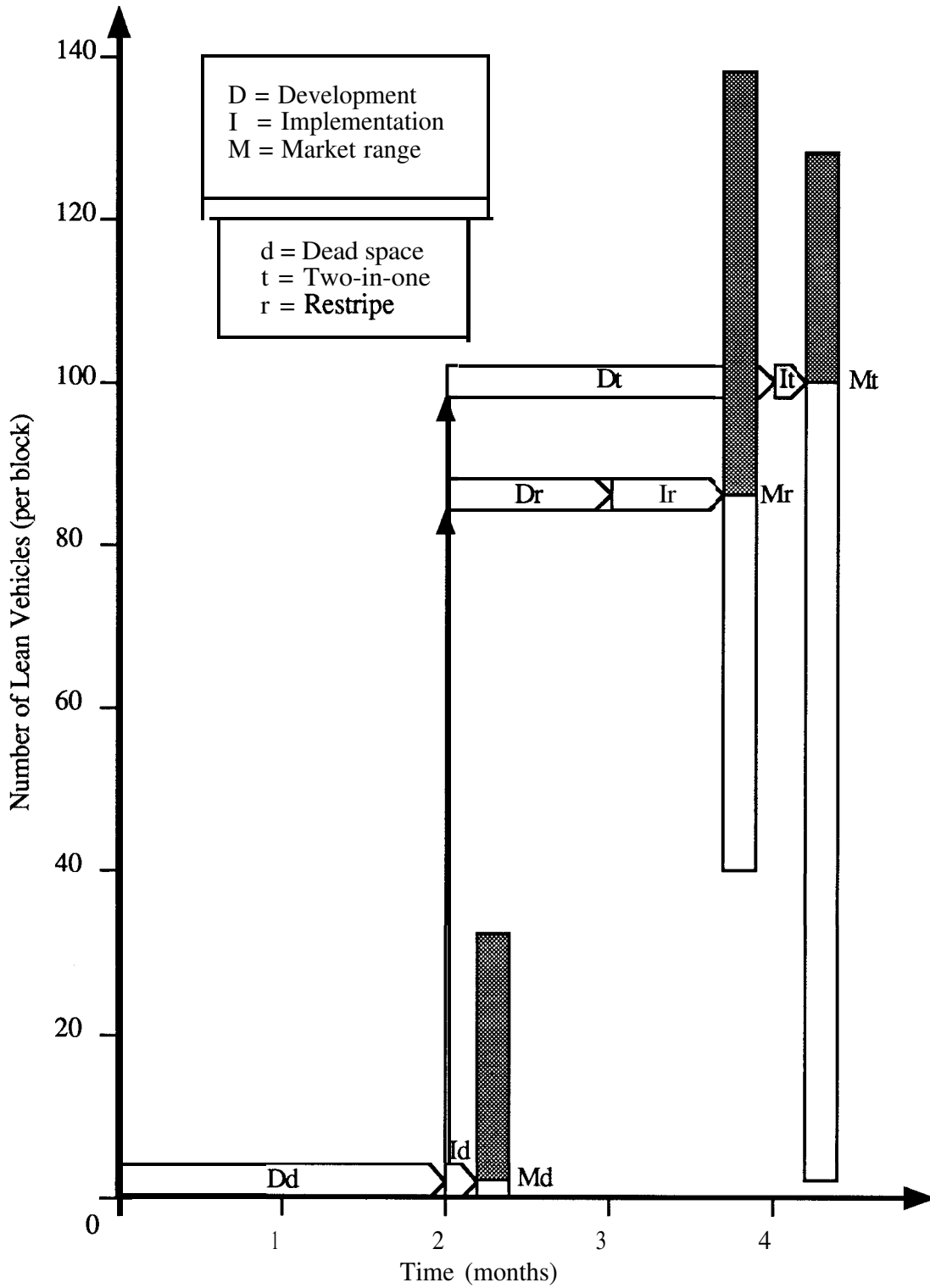

Figure 4.11. Perpendicular street parking SPAN diagram - Strategy 0.

Thus, a logical strategy for implementation, Strategy 1, can be defined as the use of dead spaces until there are no more available, followed by the gradual conversion of spaces in a single section to the two-in-one concept until a full section has been converted. Then, a different section should be restriped with the two-in-one spaces temporarily reverting to automobiles. Once the restriped section is filled with lean vehicles, the existing two-in-one spaces can be used again, and this cycle can be repeated as necessary. Strategy 1 does not include the new design concept; that would be another strategy by itself. We could call it Strategy 2, but the market limits would be the same as for Strategy 0 since we would be considering the new design concept independently.

Now that Strategy 1 has been defined, the market ranges for the technologies should be recalculated to reflect the combination of technologies. The upper and lower limits for Strategy 1 are constrained by the limits for Strategy 0, but the new limits, given in Table 4.7, show when one technology will be replaced by another. There are small gaps between the upper limit of one technology and the lower limit of the next technology due to the discreteness of technologies (i.e., the two-in-one concept would not be implemented for less than two additional lean vehicles).

It is also necessary to recalculate the first application limits to reflect the combination of technologies. The first application limit of the first technology in the strategy is the same as for Strategy 0, but the limit can be different for the other technologies depending on the relative values of the first application limit and upper limits for previous technologies. The results given in Table 4.7 were calculated on the basis described in Chapter 3, which allows us to determine if all the development and implementation costs for a given strategy can be recovered at a single location.

The SPAN diagram for Strategy 1 is shown in Figure 4.12 for surface parking lots. This diagram illustrates all three cases described in Chapter 3 regarding comparison of the first application limit to the upper limits. The **restripe** concept illustrates case 1, and the dead space concept illustrates case 3 with the dark shaded area. The two-in-one concept

Table 4.7 Market Ranges for Parking Modifications - Strategy 1

Technology (x)	Lean Vehicles (per lot, garage, or block)		
	Lower limit	Upper limit	First application
	L_x^1	U_x^1	F_x^1
<u>Parking lots</u>			
Dead spaces (d)	1	10	33
Two-in-one (t)	12	42	118
Restripe (r)	43	350	165
<u>Parking garages</u>			
Dead spaces (d)	1	15	7
Two-in-one (t)	17	47	29
Restripe (r)	48	350	70
<u>Parallel street parking</u>			
Dead spaces (d)	1	4	33
Two-in-one (t)	6	8	92
Restripe (r)	9	64	84
<u>Perpendicular street parking</u>			
Dead spaces (d)	1	2	33
Two-in-one (t)	4	102	126

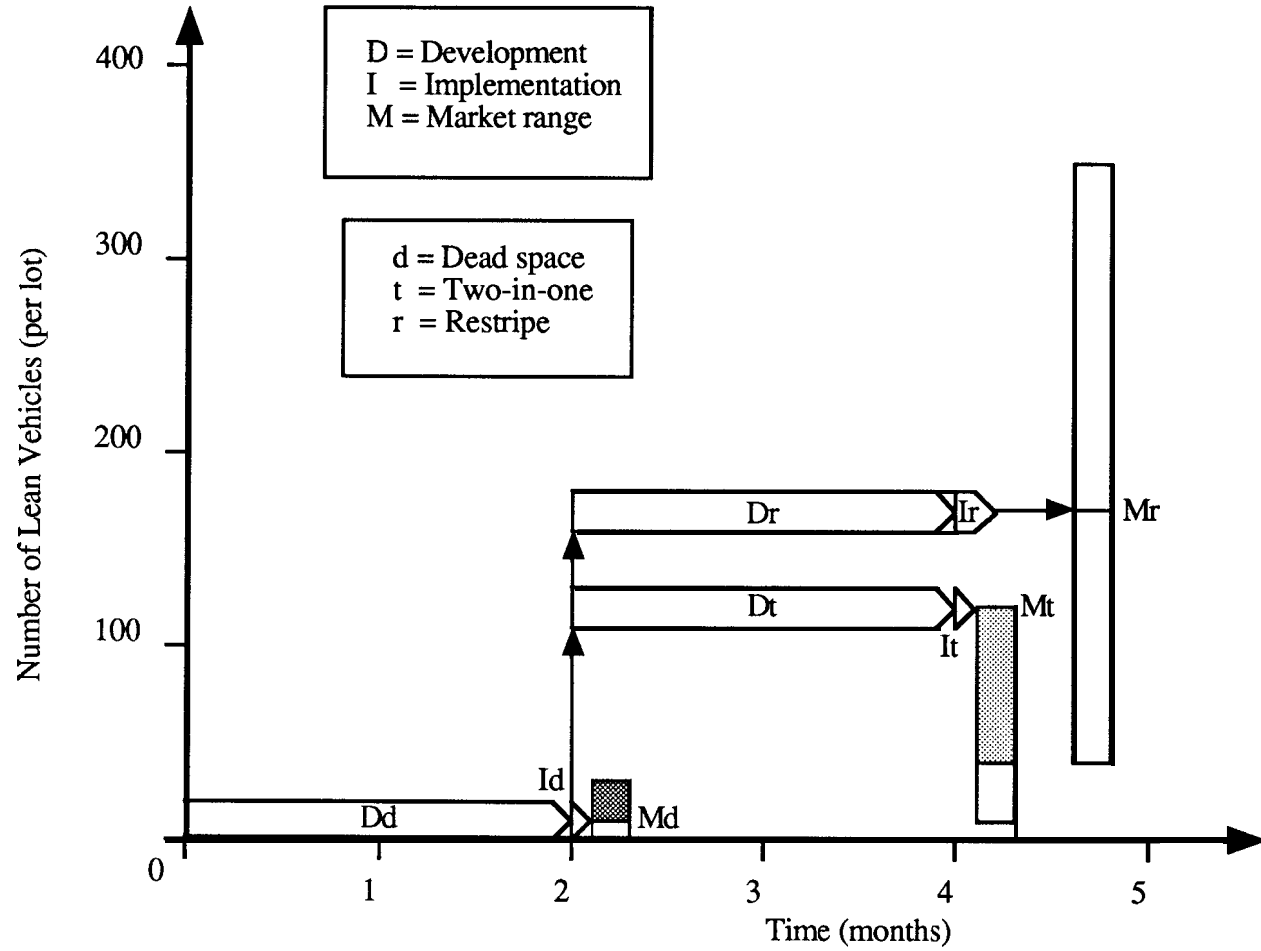

Figure 4.12. Parking lot SPAN diagram - Strategy 1

illustrates case 2 with the light shaded area representing operation above the upper limit of Strategy 1 but below the upper (physical) limit of Strategy 0.

SPAN diagrams for parking garages and parallel and perpendicular street parking for Strategy 1 are shown in Figures 4.13 through 4.15, respectively. Again, these diagrams are similar to Figure 4.12 for the parking lot situation, except that the numbers are different for each situation. These diagrams will not be discussed in detail because they do not introduce any new ideas, but a few interesting points are noted below.

In Figure 4.14, the SPAN diagram for Strategy 1 for parallel street parking, the **first** application limit for the two-in-one concept exceeds the upper (physical) limit, which in turn exceeds the upper limit for Strategy 1. In this case both light and dark shaded areas are used to define the market range (case 3 in Chapter 3).

For perpendicular street parking, restriping the entire block would actually result in fewer lean vehicle parking spaces than converting all spaces to two-in-one spaces, therefore the **restripe** concept is not included as part of Strategy 1. However, restriping the entire block should provide enough room to create an exclusive lean vehicle lane, so this concept should not be ignored.

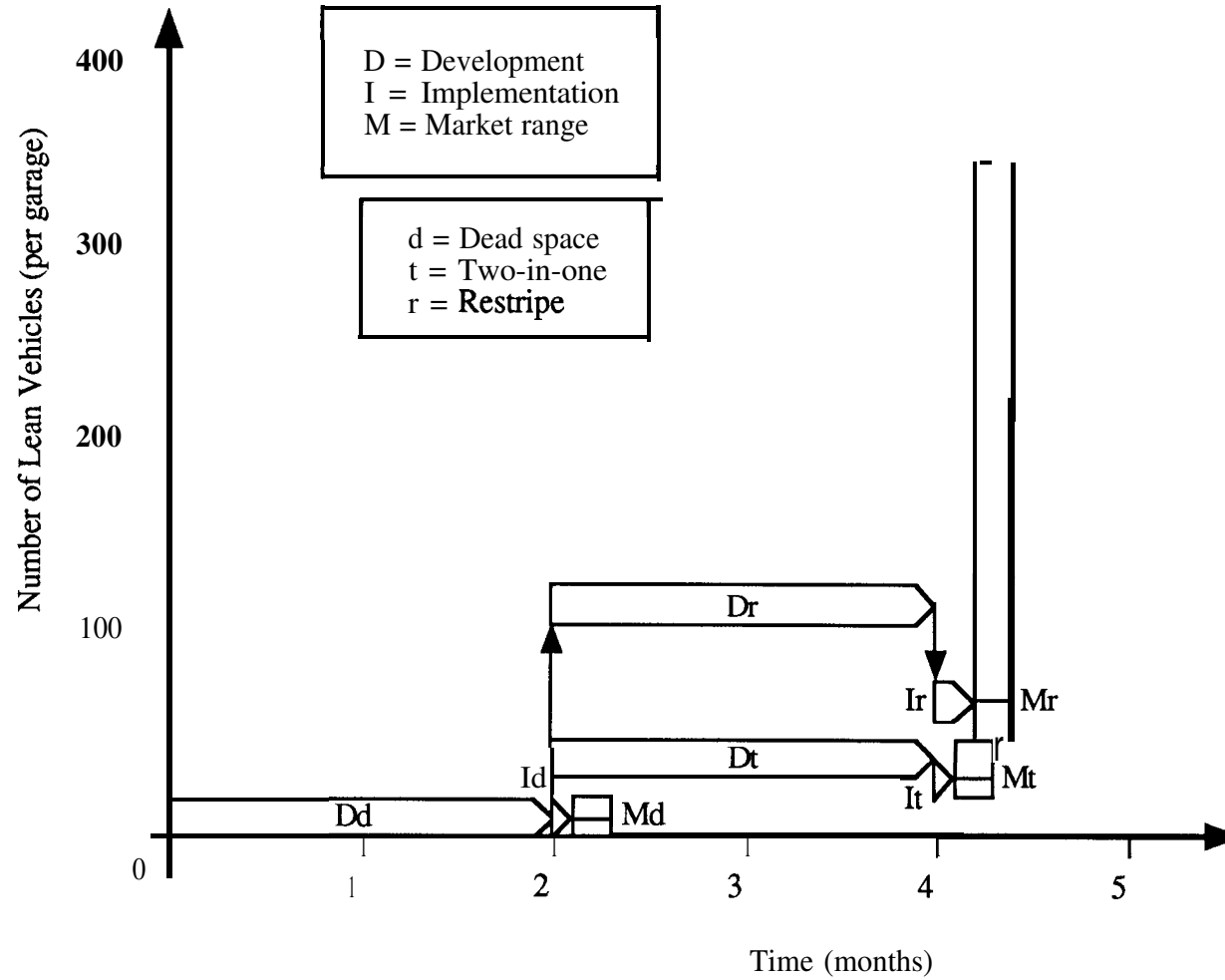

Figure 4.13. Parking garage SPAN diagram - Strategy 1.

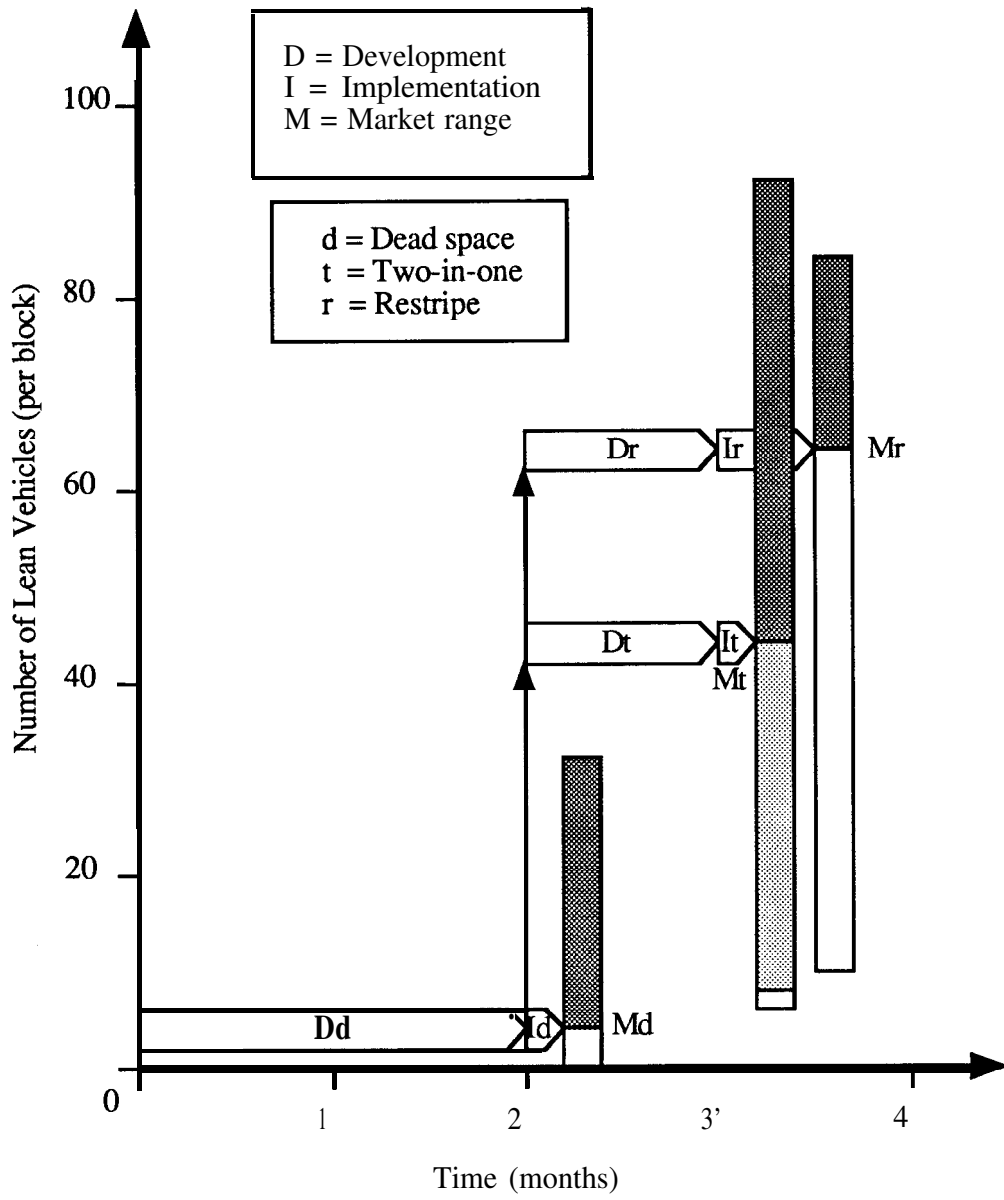

Figure 4.14. Parallel street parking SPAN diagram- Strategy 1.

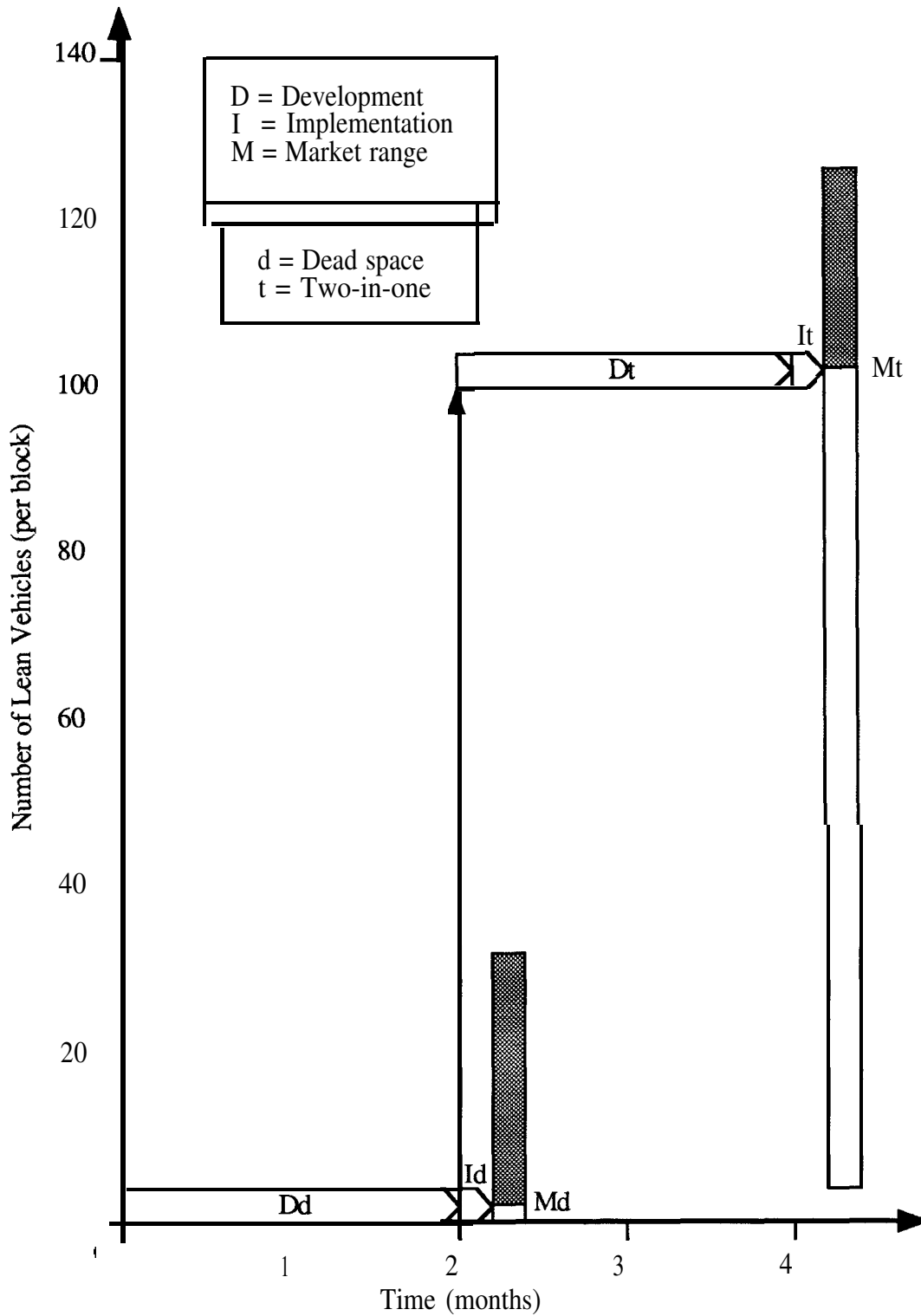

Figure 4.15. Perpendicular street parking SPAN diagram - Strategy 1.

5. CASE STUDY: LEAN VEHICLE ROAD FACILITIES

In addition to the potential parking space and parking cost reductions, it should be possible to devise operational facilities which take advantage of the size and performance of lean vehicles. In fact, special parking facilities for lean vehicles will not do any good if lean vehicles cannot operate on roads. Existing road facilities might have to be modified to accommodate and encourage the use of lean vehicles in order to achieve any of the potential benefits that are envisioned.

One of the largest potential benefits from lean vehicles is reduced congestion and delay provided by the higher capacity of roadways carrying lean vehicles (estimates of the nature and magnitude of the capacity increase are discussed in Appendix B). The capacity increase provided by lean vehicles would be due to a combination of the geometric effect of shorter vehicles and the possibility of side-by-side driving, which should be possible given their narrow width.

The potential for time savings and the expected reduction in fuel consumption and pollution generation provide motivations for the modification of existing road facilities. Potential modifications to road facilities are discussed in this chapter, with particular emphasis on adjustments to highway links since other road situations (arterial links, intersections, and interchanges) would be modified with similar adjustments.

5.1. Road Modification Concepts

There are many possible modifications of road facilities which would create special lanes to accommodate lean vehicles. The wide variety of special lanes can be classified by situation and solution, as presented in Table 5.1. The following sections discuss the characteristics of the special lane categories which are not obvious from the table. This will be followed by discussions of appropriate solutions for several particular situations.

Table 5.1 Classification of Special Lanes

SITUATION	SOLUTION
<u>Original Facility Type</u>	<u>Special Lane Usage</u>
Highway	Exclusive (lean vehicles & motorcycles)
Arterial	Shared (single file, side-by-side)
<u>Link/Bottleneck</u>	<u>Special Lane Operation</u>
Intersection/Interchange	Continuous (all hours)
<u>Original Facility Elevation</u>	Convertible (commute hours only)
At-grade	Reversible (commute direction only)
Depressed	<u>Special Lane Location</u>
Embankment	Vertical (same level, above, below)
Viaduct/Bridge	Lateral (existing, shoulder, median)
Tunnel	New Right-of-way

5.1.1. Situations

The variety of particular situations can be classified by original facility type and elevation. It should be noted that not all combinations of the situation categories given in Table 5.1 actually exist. For instance, most arterial intersections are at-grade. The combinations are not completely independent, but each situation has distinct characteristics which suggest different solutions.

Original Facility Type

The facilities most likely to be improved by special lanes can be classified as either arterials or highways. The situations can be further divided into links or bottlenecks, and

intersections or interchanges. Of course arterial intersections and highway interchanges can be considered as bottlenecks, but the term “bottleneck” here refers to links which have lower capacity than upstream and downstream sections. Bottlenecks such as bridges, tunnels, and viaducts would probably be the first links to receive special lean vehicle lanes.

Original Facility Elevation

The majority of intersections and a large percentage of link mileage are at-grade, but interchanges by definition have at least partial grade separation. Also, the portions of links which are not at-grade often are bottlenecks because of the high cost of additional capacity. Any section of a facility which is not at-grade presents unique challenges because median and shoulder space is limited or nonexistent.

5.1.2. Solutions

The variety of potential solutions can be classified by special lane usage, operation, and location. However, not all combinations of the solution categories given in Table 5.1 are necessary or even practical. The solutions depend somewhat on the situation, highway link, arterial link, intersection, or interchange, but most concepts are common to all situations.

Special Lane Usage

Usage of special lanes refers to what types of vehicles would be allowed; lanes could be either exclusive or shared with cars and trucks, as shown in Figure 5.1. Exclusive lanes would be limited to lean vehicles and motorcycles only, thus they could be narrow and could have lower weight limits. Shared lanes for mixed traffic would allow lean vehicles to drive on existing lanes in single file (one-to-one) and/or side-by-side (two-to-one). Side-by-side driving in shared lanes should be possible for narrow lean vehicles, but this might require additional stripes down the middle of the lane or lane centering technologies to guide the lean vehicles.

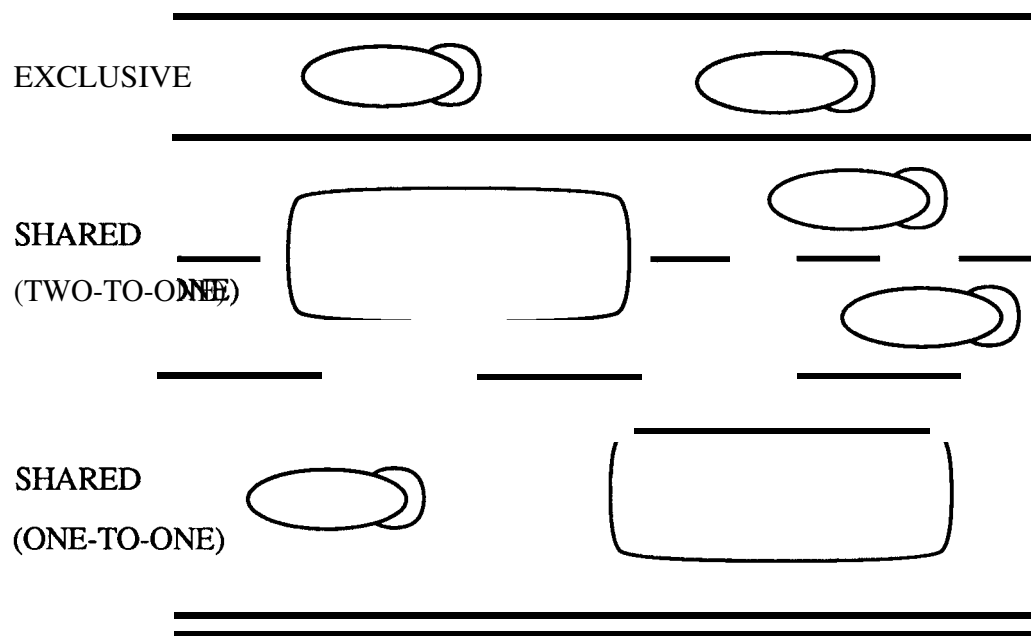

Figure 5.1. Shared and exclusive lean vehicle lanes.

Special Lane Operation

A special lean vehicle lane need not be in continuous operation and unidirectional. Convertible lanes could operate only during commute hours by temporarily using a highway shoulder or restricting parking on an arterial. Another possibility would be to temporarily reconfigure the lanes on an existing roadway using signs and/or cones. For corridors with strong directional flows, reversible lanes could operate in the primary commute direction only, depending on the time of day. These could be separate median lanes on a highway or center lanes on an arterial. Reversible and/or convertible special lanes would be “intelligent” highway links responsive to changing conditions.

Special Lane Location

The least expensive special lanes will be located on the existing roadway or shoulders (inside or outside), at the same level as the existing facility. This includes any part of the existing roadway which is used for high-occupancy vehicle (HOV) lanes. Beyond modification of the existing roadway, new lanes might be built in the median, and

elevated lanes (Figure 5.2) or intersection flyovers could be built above the existing roadway or shoulders.

Other potential (and expensive) solutions include outrigger lanes on viaducts or bridges, and stacked lanes in tunnels. Outrigger lanes would be lightweight structures cantilevered from the sides of existing viaducts or bridges with extra load capability, as shown in Figure 5.3. An exclusive lean vehicle lane could be stacked above another lean vehicle lane within a rectangular tunnel to take advantage of the low vehicle height (Figure 5.4). Similar lanes could also be hung from the top center of circular or arched tunnels to take advantage of extra space above car and truck lanes (Figure 5.5). Although special lanes in new tunnels below existing roadways would be very expensive, many large bridges, such as the Golden Gate Bridge in San Francisco, have room within the structure below the roadway which could be used for special lanes (Figure 5.6). This might be less expensive than building outrigger lanes as described above.

Special lanes could also be built in new rights-of-way by taking advantage of the reduced width and structural requirements of lean vehicles. These new facilities could be used to bypass bottlenecks or to access parking facilities directly from a highway. For instance, a tunnel through a hill could be bypassed by going over the hill on a special lane with a steeper grade negotiable by lean vehicles (and/or sharper curves negotiable by leaning vehicles like the Lean Machine). The new rights-of-way could include abandoned railroad or interurban lines and many utility rights-of-way, such as those for electric power lines and gas or water pipelines. Also, drainage facilities in culverts could be covered and used as special lanes.

5.1.3. Highway Links/Bottlenecks

The previous sections described the variety of special lane situations and potential solutions. This section will focus on the appropriate solutions for a particular situation: highway links and bottlenecks which are at-grade.

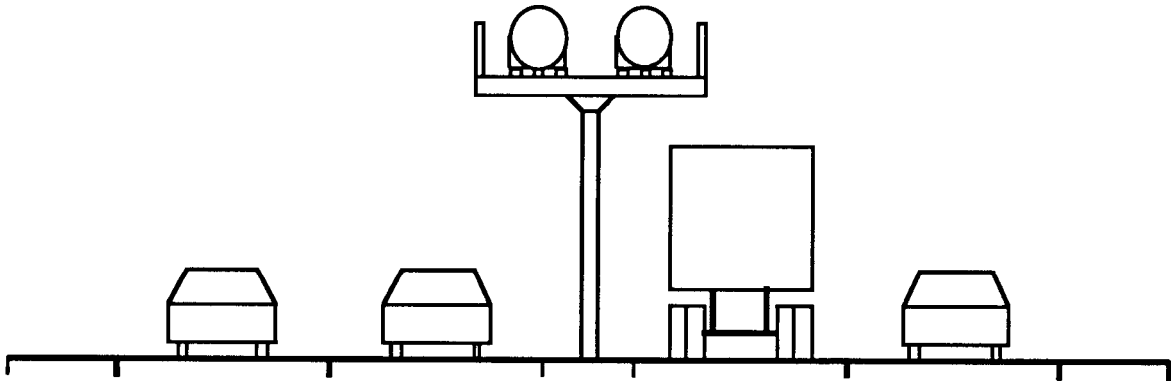

Figure 5.2. Elevated lean vehicle lanes in highway median.

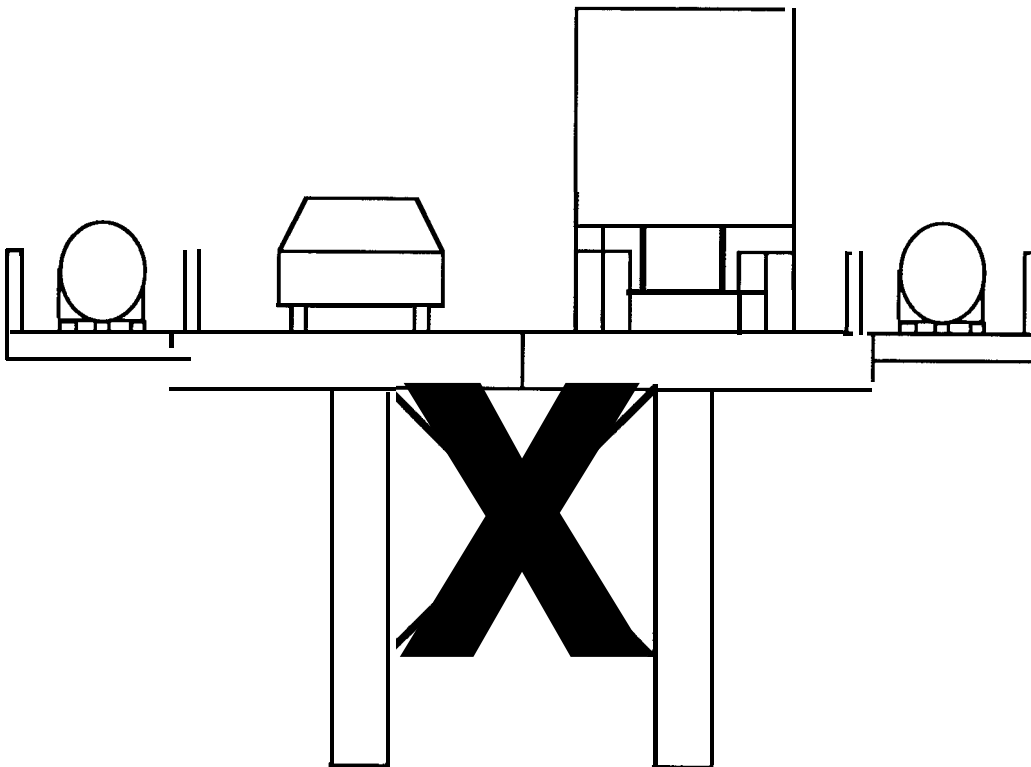

Figure 5.3. Outrigger lean vehicle lanes on bridge or viaduct.

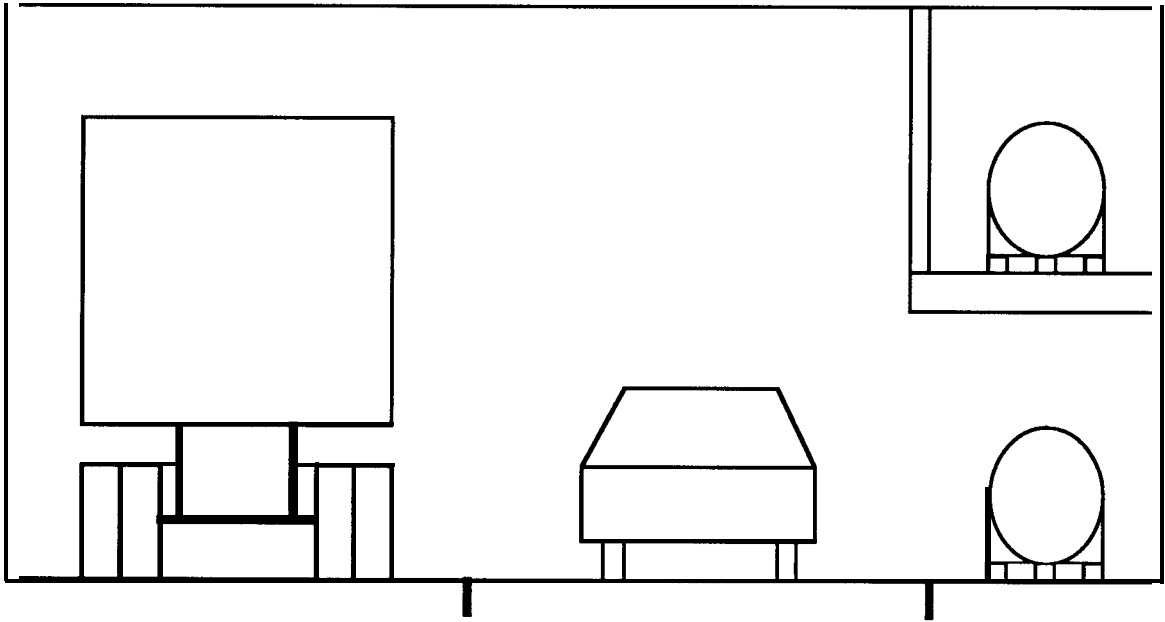

Figure 5.4. Stacked lean vehicle lanes in a rectangular tunnel.

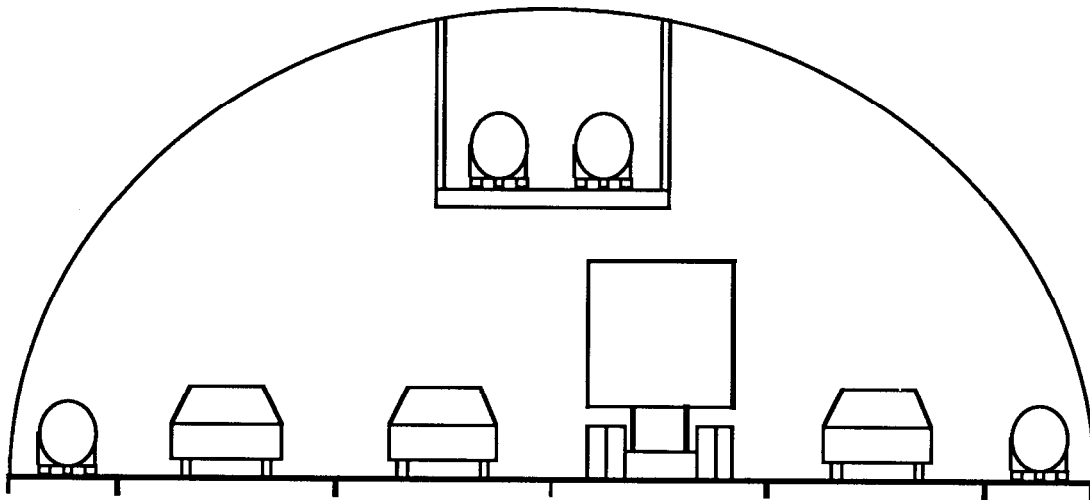

Figure 5.5. Stacked and shoulder lean vehicle lanes in a circular tunnel.

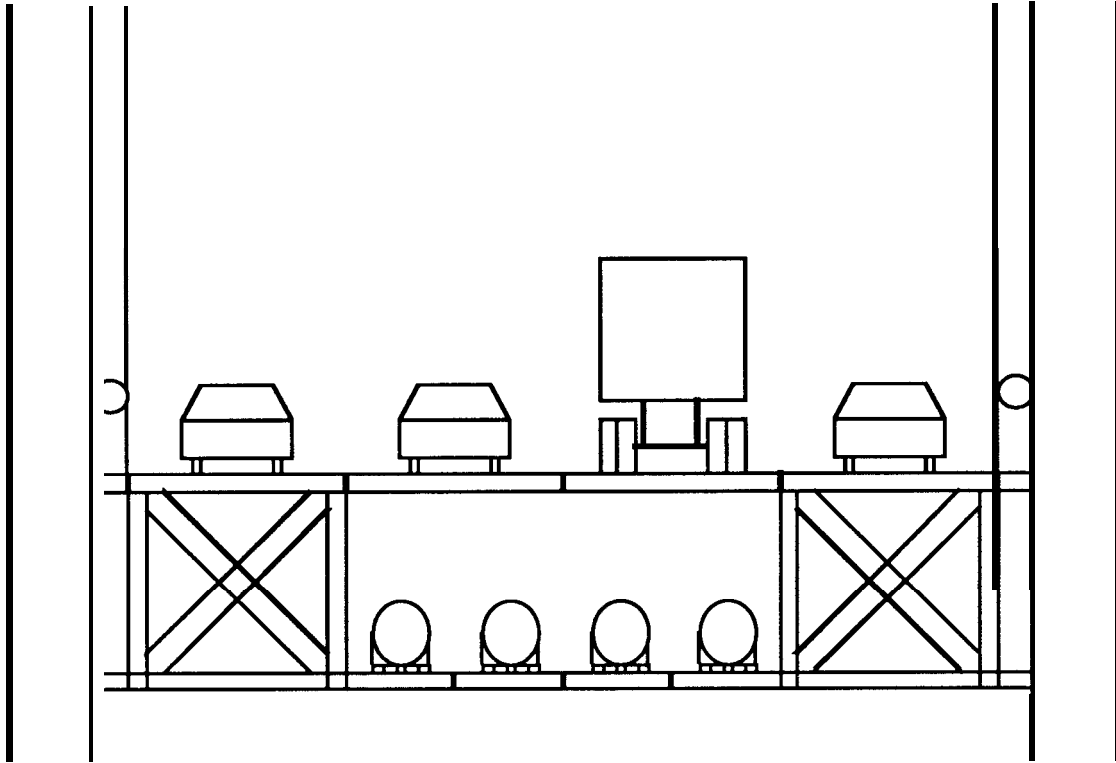

Figure 5.6. Lean vehicle lanes within the structure of a large bridge.

Shared Existing Lanes

One simple solution is the shared use of existing lanes by mixed traffic. Cars and trucks would operate as usual in the full lane, and lean vehicles would drive in single file or side-by-side if they could pair off. As mentioned above, striping along the center of the lane might be necessary for side-by-side driving.

Convertible Existing Lanes

A more flexible and more expensive option would involve converting some shared lanes into exclusive lean vehicle lanes during certain hours only. This would provide maximum capacity only when it is needed and could be done with a combination of striping patterns, signs, cones and/or signals.

Exclusive Shoulder Lanes

The easiest and cheapest solution to implement would be exclusive lean vehicle lanes on the shoulders of highways. Paved highway shoulders may be strong enough to support extensive use of lean vehicles but not cars and trucks. These shoulder lanes could either operate continuously or they could be convertible by limiting their use to peak hours.

Exclusive Lanes on Existing Roadway

Instead of shoulder lanes, the existing standard lanes could be restriped to provide an exclusive lean vehicle lane at the edge of the roadway (which has a much higher capacity than a single shared lane). The restriped standard lanes would have to be wide enough for cars and trucks, perhaps by restricting trucks to one wide lane.

Elevated Lanes

A more expensive option would be to build elevated lanes above a highway for the exclusive use of lean vehicles. The cross section of two elevated lanes located above the median of a highway is shown in Figure 5.2. Access to these relatively lightweight structures with low load limits would have to be limited. Although the idea is the same, these structures would be much less massive and expensive than elevated lanes for traditional vehicles, such as the Harbor Freeway Transitway in Los Angeles. Of course, lean vehicles could be allowed to use existing elevated structures, or elevated outrigger lanes could be added for lean vehicles only.

New Road in Median

Another more expensive option would be to construct new lean vehicle lanes in the median of a highway. These new lanes would have reduced pavement and structural requirements and access would have to be limited to lean vehicles only.

Reversible Lanes in Median

The lanes on the new roadway in the median could also be made reversible. Operation of these reversible lanes would be similar to the reversible “express” lanes on the Kennedy Expressway in Chicago and the reversible “high occupancy vehicle” (HOV) lanes

on I-15 north of San Diego. Again, lean vehicles could be allowed to use existing reversible lanes in any of the manners discussed above.

5.1.4. Arterial Links/Bottlenecks

The treatment of arterial links and bottlenecks is similar to the highway situation except for a few important differences. Arterials in urban and suburban areas usually have no median and/or shoulders, thus some of the appropriate solutions will be different than for highways. For instance, reversible lanes cannot be located in the median if it does not exist, thus they would have to be located on the existing roadway. Instead of shoulders, arterials often have street parking which can be restricted during certain hours or removed permanently in key locations to provide special lanes. As discussed in Chapter 4, perpendicular and angled spaces can be modified to provide an additional exclusive lane for narrow lean vehicles while retaining street parking. Another important difference between arterials and highways is that arterials are frequently interrupted by intersections and driveways. These interruptions provide potential barriers to the continuity of special lean vehicle lanes.

5.1.5. Arterial Intersections

Special lane applications at intersections have much in common with applications for links and bottlenecks. However, the potential gains are even greater at intersections because of the larger capacity increases provided by lean vehicles at saturation flow compared to free flow.

Exclusive and Shared Existing Lanes

At many intersections it should be possible to take advantage of unused existing space to provide exclusive through, left-turn, or right-turn lanes for lean vehicles. Exclusive lanes could also be created by restriping existing lanes to make them slightly narrower, and/or by relocating curbs in the median or at the outside edge.

Another simple solution for intersections is the shared use of existing through, left-turn, and right-turn lanes by mixed traffic. Cars and trucks would operate as usual in the full lane, and narrow lean vehicles would drive side-by-side in the half-width lanes created by adding additional striping down the center of the full lane.

Flyover Lanes

As the number of lean vehicles using an intersection increases, flyovers could be built to carry lean vehicles over the intersection without stopping. These flyovers would be scaled down versions of those that already exist for automobiles in Europe and elsewhere [Bagon, 1980, and Pleasants, 1980]. Lean vehicle flyovers would have cross sections similar to elevated lean vehicle lanes, and access to these relatively lightweight structures with low load limits would have to be limited.

A flyover with a single reversible through lane located in the median could be used at intersections with strong directional traffic, as shown in Figure 5.7. For lean vehicles initially in special lanes at the outside edges of the street, flyovers located in the median might require lane changes prior to the intersection. The alternative is to permanently remove some parking spaces near the intersection and locate the flyovers (one for each direction) at the outside edges of the street.

Flyovers for left turns could also be constructed, but the volume of left turns is usually only about 10% of the through volume and left-turn flyovers could probably not be used in two directions. Right-turn flyovers are probably unnecessary because right-turns do not conflict with other movements, thus grade separation would not be needed unless the intersection is restricted laterally.

Multiple flyover lanes could be added if the queueing delay for vehicles approaching single flyover lanes increases and approaches the delay of proceeding through the intersection. Eventually, intersection flyovers could be connected to continuous elevated lanes for lean vehicles as on highways.

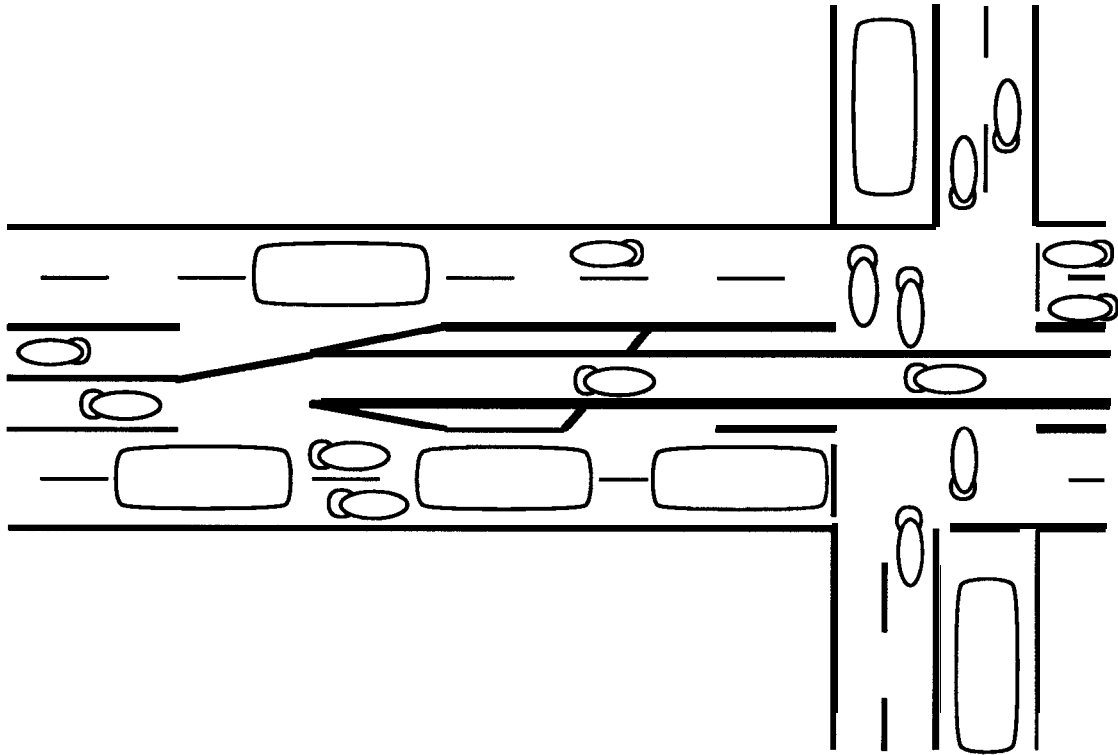

Figure 5.7. Intersection with shared lanes and reversible flyover for lean vehicles.

51.6. Highway Interchanges

The appropriate types of special lanes at highway interchanges involve a combination of the concepts discussed above. Highway to highway interchanges can be treated like a highway link, as can the highway portion of an interchange with an arterial. For a fully grade-separated interchange with an arterial the arterial portion is treated like an arterial link, and for a diamond interchange the arterial portion is treated like an arterial intersection.

Exclusive lanes for lean vehicles could be located on the shoulders of ramps without interfering with the flow of cars and trucks. By taking advantage of the tighter turning radius of lean vehicles, the inside radius shoulders of the ramps could be used which would permit continuity with shoulder lanes on the links. A potential conflict exists when a shoulder lane must go through a merge or diverge area. In this case either the lean

vehicle traffic would have to mix with other traffic, as shown for the diamond interchange in Figure 5.8, or it would have to be diverted around or over the ramp traffic. If warranted, exclusive lean vehicle flyovers for through traffic could be built over merge and diverge areas, as shown in Figure 5.9.

5.1.7. Special Structures

Several related structures for special lean vehicle lanes have been discussed individually above, including intersection or ramp flyovers, elevated lanes on highways or arterials, outrigger lanes on viaducts or bridges, and stacked lanes in tunnels. These structures would have many common elements, and their development and design would be related. They would be similar to bicycle and pedestrian overpasses in both size and shape, and could probably be prefabricated and erected rapidly at the site [Bagon, 1980, and Pleasants, 1980].

Because of their fairly high cost, these exclusive lean vehicle structures would usually not be the **first** type of special lane to be implemented in a particular situation. The initial facilities would most likely be either facilities which are shared with conventional vehicles or inexpensive conversions of existing facilities. Furthermore, all of these structures would require other special lanes at their entrances and exits. For example, flyovers and outriggers would require exclusive lanes both before and after the structures. Similarly, elevated lanes and stacked lanes would require structures very similar to flyovers at their endpoints.

5.2. Activity Networks

An activity network representation of potential modifications to a highway link is presented in Figure 5.10. The structure of this activity network differs from those for parking facilities in three ways: there are more technologies represented, there are more interconnections between the activities for different technologies, and there are generic development activities which are shared by several technologies. The generic development

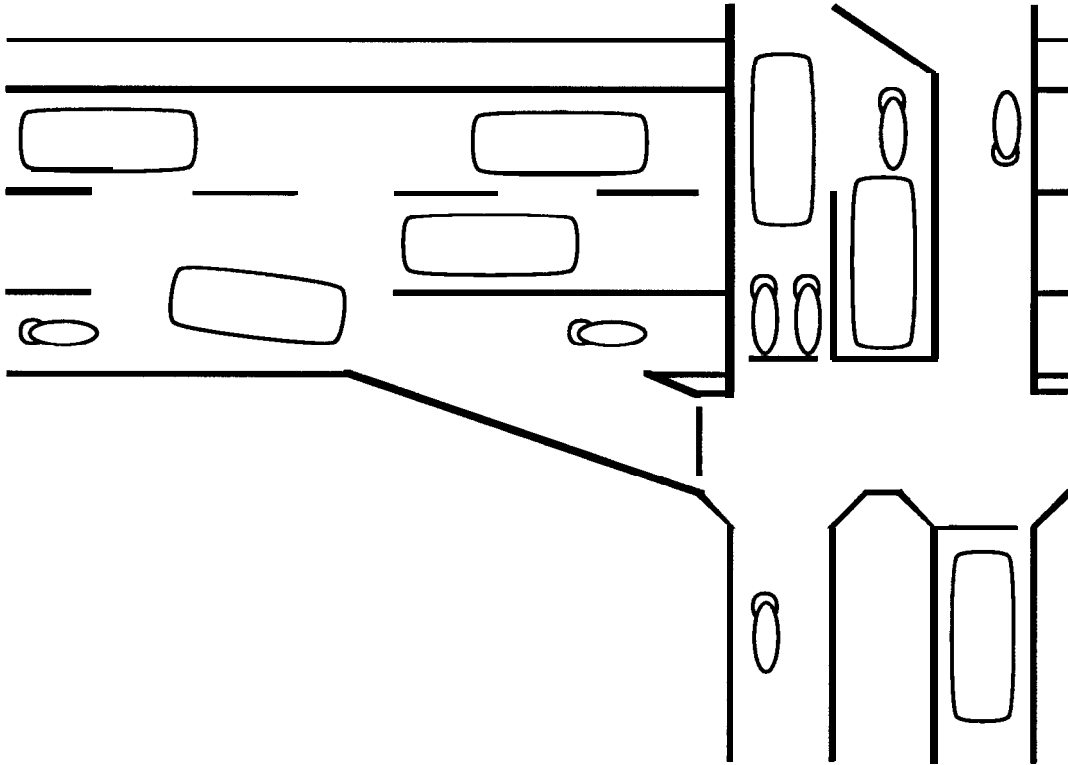

Figure 5.8. Diamond interchange with shoulder lane for lean vehicles.

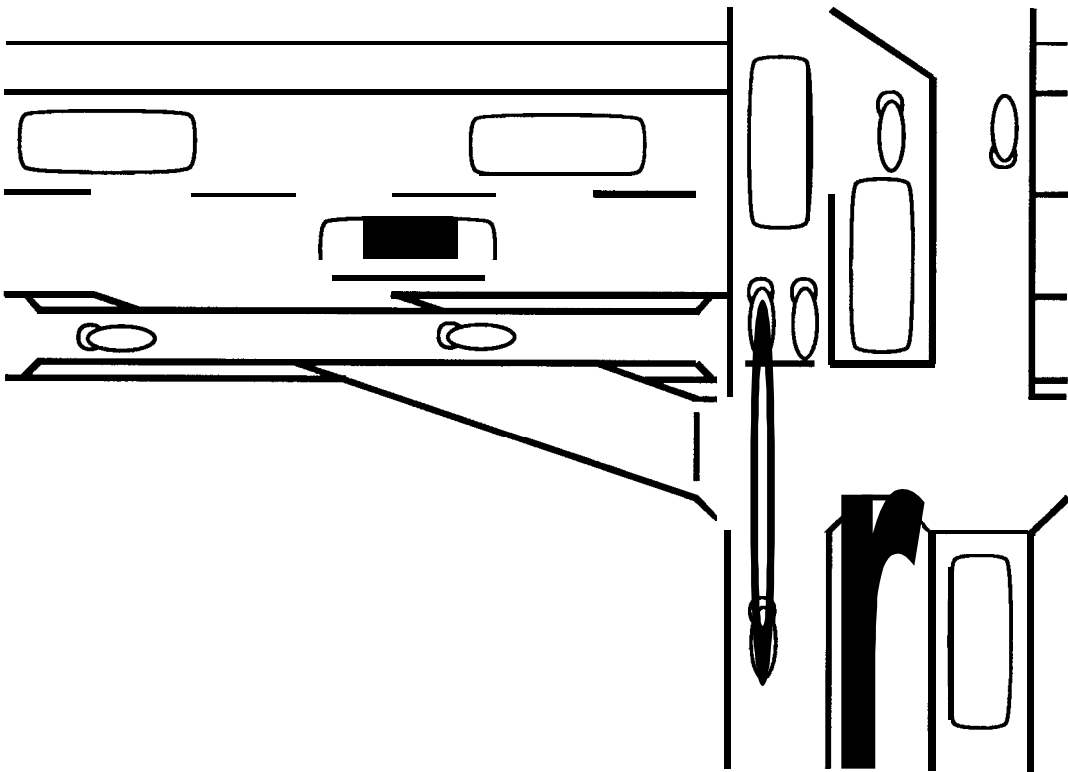

Figure 5.9. Diamond interchange with ramp flyover for lean vehicles.

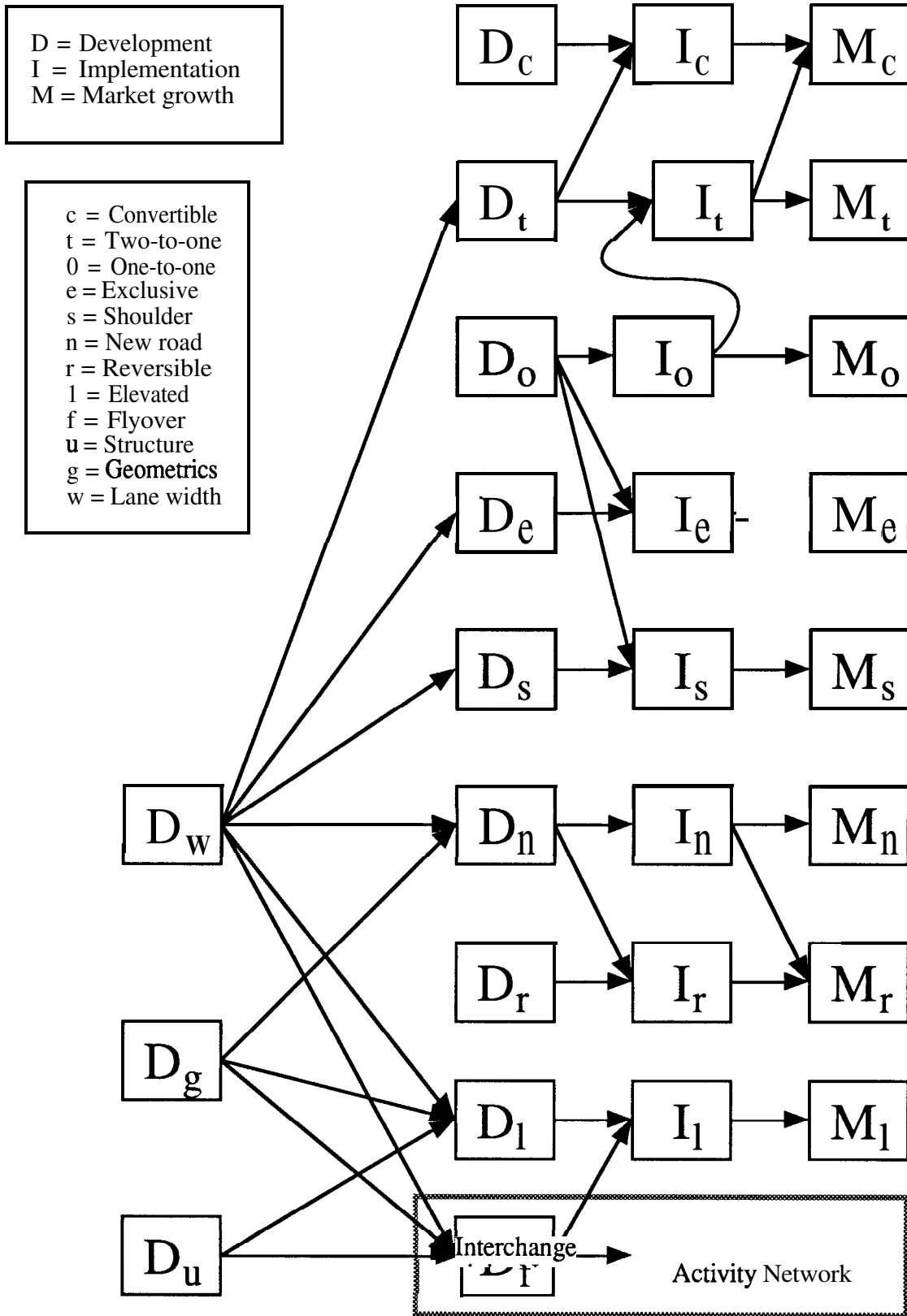

Figure 5.10. Highway activity network.

activities are to determine required lane width and other geometric parameters and to design a basic structure that can be used for elevated lanes, flyovers, and other related technologies.

The one-to-one development activity involves determining what modifications must be done to existing roadways (i.e. drains, guardrails, edge treatment, potholes, bumps, etc.) to allow operation of lean vehicles. Thus, this activity leads directly or indirectly to several other technologies (two-to-one, convertible, shoulder, and edge exclusive). The one-to-one concept must be implemented before the two-to-one concept, otherwise stripes down the middle of the lane would be covered by any pavement work done for the one-to-one concept. The shoulder lane concept is an exclusive lane which could operate continuously or during peak periods only. The edge exclusive lane is created by restriping the existing lanes to carve out space for lean vehicles.

The convertible lane concept involves operating the two-to-one shared lane as two exclusive lanes during peak periods. This leads to the double connection shown in the activity network because the two-in-one concept must be developed and implemented before the convertible concept can be implemented and operate, respectively. A similar relationship holds for the new road concept and the reversible lanes concept. The new road is assumed to be located within the existing right-of-way, probably in the median if possible.

An elevated lane will require something very much like one-half of an interchange flyover at each end of the elevated facility, hence the connection with the flyover development activity. Reversible elevated lanes would also be possible, but they will not be considered for this analysis in order to avoid unnecessary complication of the activity network. They would operate just like reversible new road lanes, thus they would not introduce any new ideas.

The activity network representing potential modifications to an arterial link is shown in Figure 5.11. This diagram is similar to that for highway links, with a few exceptions.

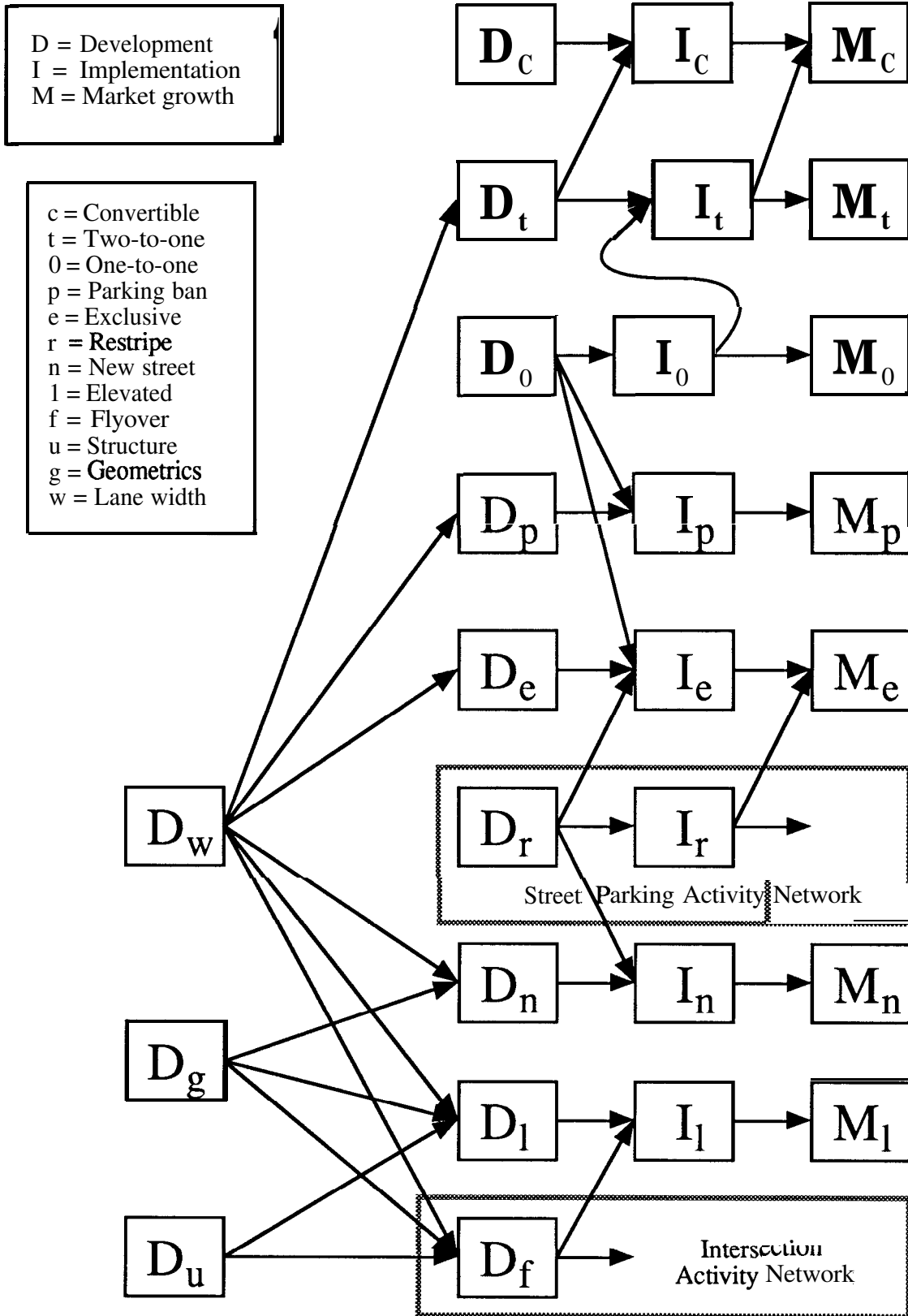

Figure 5.11. Arterial activity network.

The shoulder lane concept of the highway situation is replaced by the parking ban concept, which is similar. This involves the permanent or temporary restriction of street parking to create an exclusive lane. The exclusive lane located at the edge of the street involves restriping the parking spaces as well as the existing lanes. Part of the street parking activity network has been included because the **restripe** parking concept feeds into the exclusive lane concept and the new street concept. The reversible concept has been eliminated for simplicity, but reversible elevated lanes or exclusive lanes would be possible.

The intersection activity network shown in Figure 5.12 is very similar to the arterial activity network, with a few exceptions. The roles of the flyover concept and the elevated lane concept are reversed because the elevated lane concept is part of the arterial activity network. A new intersection concept has not been included, but a reversible intersection flyover has been included in the diagram.

The activity network for modifications of an interchange is shown in Figure 5.13. This diagram is similar to the highway activity network except that the roles of the flyover concept and the elevated lane concept are switched, as was the case for intersections and arterials. Also, the reversible concept is not included because reversible new interchange ramps are unlikely.

The structures activity network in Figure 5.14 ties several related technologies together: flyovers, elevated lanes, new ramps, stacked lanes in tunnels, and outrigger lanes on bridges. But this network is different because these technologies do not compete against (or complement) one another in the same situation, as is the case for all of the previous activity networks. These technologies are only related by the development activities which they share. Thus, Strategy 0 market limits could be calculated for this activity network, but other strategies do not exist because these technologies would not be combined at any one location.

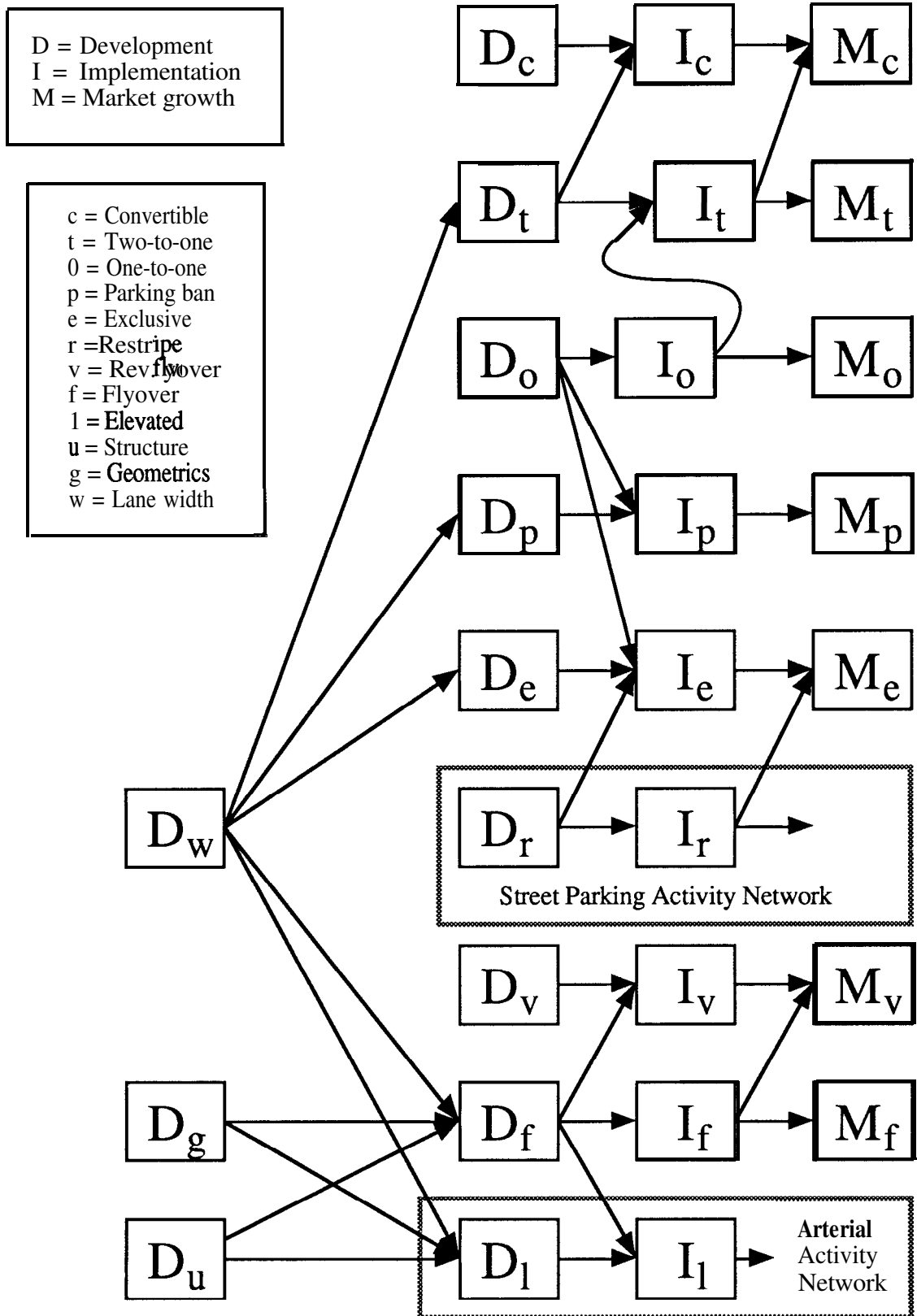

Figure 5.12. Intersection activity network.

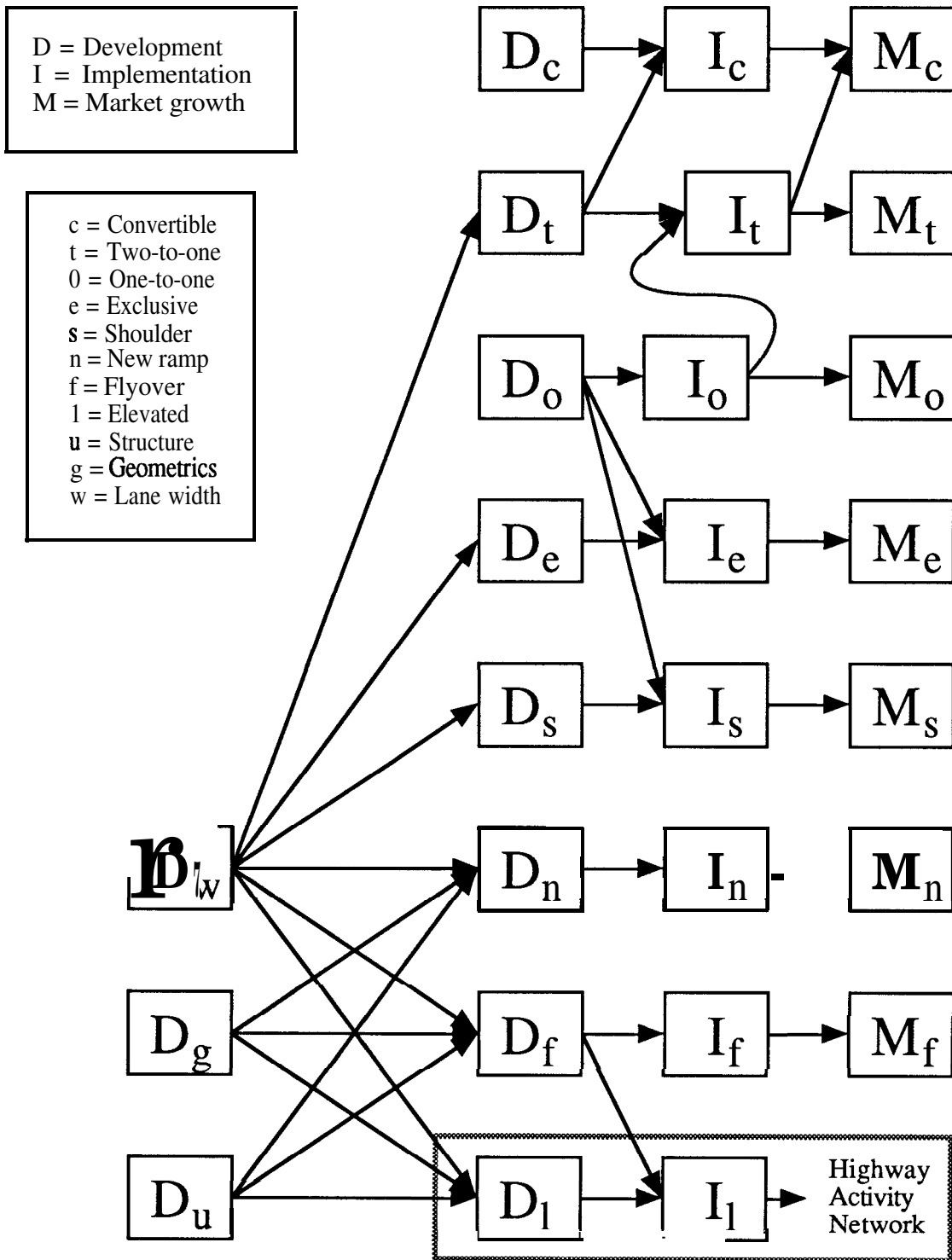

Figure 5.13. Interchange activity network.

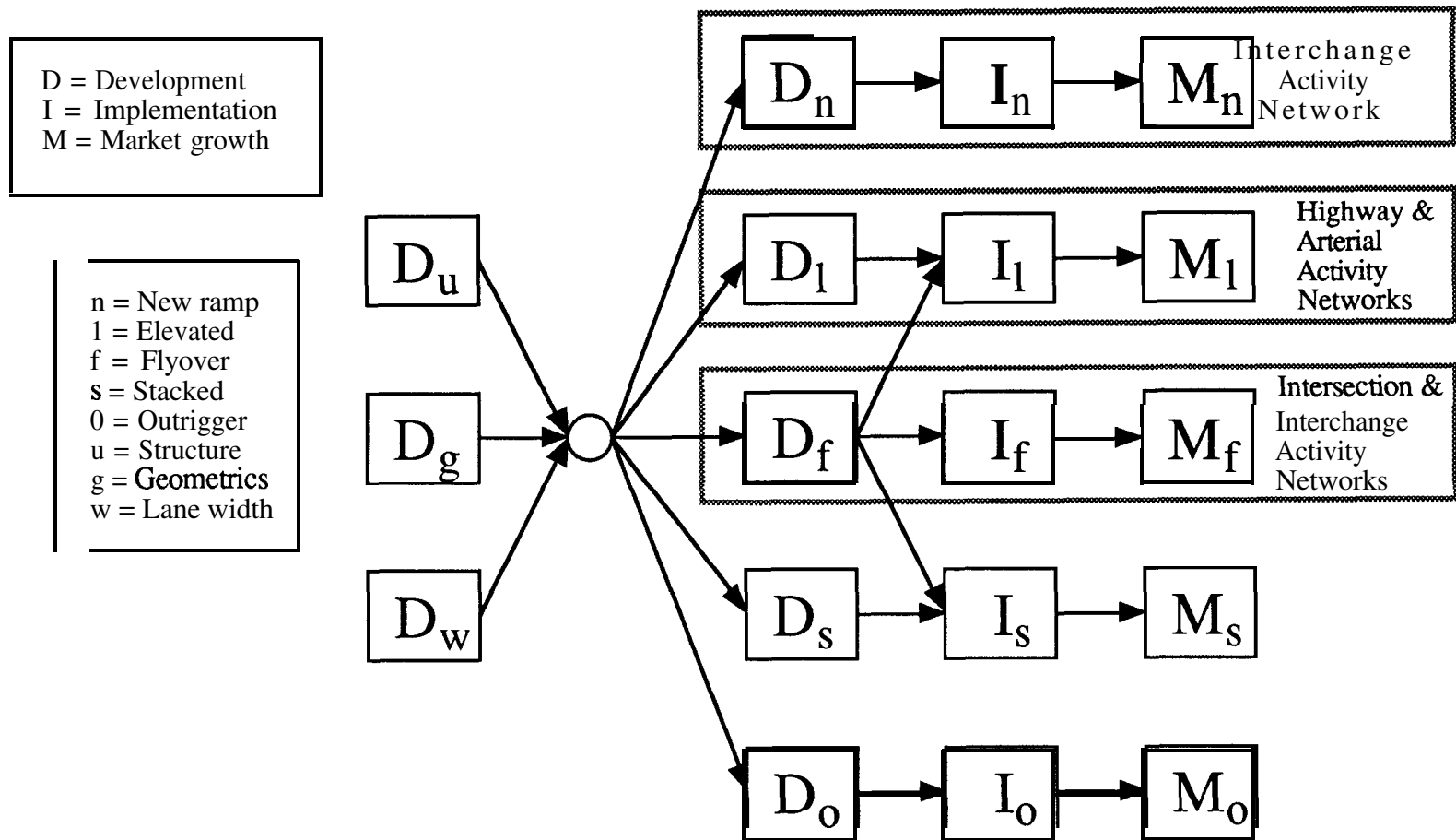

Figure 5.14. Structures activity network.

5.3. Market Range Calculations

Activity time and cost estimates and market range calculations will be made for the highway situation only. Estimates and calculations will be performed for a highway bottleneck since that is where adjustments would be concentrated initially. Calculations and diagrams will not be presented for the other road situations, because the results would be similar except for the numerical values. The differences would be comparable to those for the various parking situations. The difference between arterials and highways would be due only to the parameter values, as is the difference between surface parking lots and garages. Intersections and interchanges change the perspective slightly compared to arterials and highways, about as much as parallel and perpendicular street parking compared to parking lots and garages.

5.3.1. Benefits

The benefits of special lean vehicle lanes are calculated on the basis of reduced delay and reduced fuel consumption. The time savings calculations depend on an estimate of the delay at the bottleneck, which is discussed below.

Delay Estimation

For the sake of calculating delay, the bottleneck is assumed to have a quadratic arrival rate, $h(t)$, given by

$$\lambda(t) = \lambda(t_2) - \beta(t - t_2)^2 \quad (5.1)$$

where t_2 is the time of the maximum arrival rate [Newell, 1982, pp. 34-36]. The parameter β is a measure of the curvature of the arrival curve and is defined as

$$\beta = \frac{\lambda(t_2) - \lambda(t_0)}{(t_2 - t_0)^2} \quad (5.2)$$

where t_0 is an arbitrary reference time before the peak period.

The arrival curve is obtained by integrating the arrival rate over time.

$$A(t) = \int_{t_0}^t h(z) d\tau = \lambda(t_2) (t - t_0) - \beta \left[\frac{(t - t_2)^3}{3} + \frac{(t_2 - t_0)^3}{3} \right] \quad (5.3)$$

If the maximum arrival rate, $\lambda(t_2)$, exceeds the capacity, μ , there will be a queue, $Q(t)$, from time t_1 to time t_4 , as shown by the cumulative arrival and departure curves in Figure 5.15.

$$Q(t) = \frac{\beta}{3} (t - t_1)^2 (t_4 - t) \quad (5.4)$$

$$t_1 = t_2 - \left[\frac{\lambda(t_2) - \mu}{\beta} \right]^{\frac{1}{2}} \quad (5.5)$$

$$t_4 = t_1 + 3 (t_2 - t_1) \quad (5.6)$$

The maximum queue, Q_{\max} , occurs at time t_3 .

$$Q_{\max} = Q(t_3) = \frac{\beta}{6} (t_3 - t_1)^3 \quad (5.7)$$

$$t_3 = t_2 + \left[\frac{\lambda(t_2) - \mu}{\beta} \right]^{\frac{1}{2}} \quad (5.8)$$

The total delay, W , is equal to the area between the arrival curve and the departure curve, and is obtained by integrating the queue over time.

$$w = \int_{t_1}^{t_4} Q(\tau) d\tau = \frac{9 \{ \lambda(t_2) - \mu \}^2}{4 \beta} \quad (5.9)$$

Lean vehicles are expected to arrive at rates proportional to that of the other traffic: more during the peak period and less during off-peak periods, with the ratio depending on the number of vehicles to arrive during the peak period.

$$\lambda_L(t) = \frac{m}{N_A} \lambda_A(t) \quad (5.10)$$

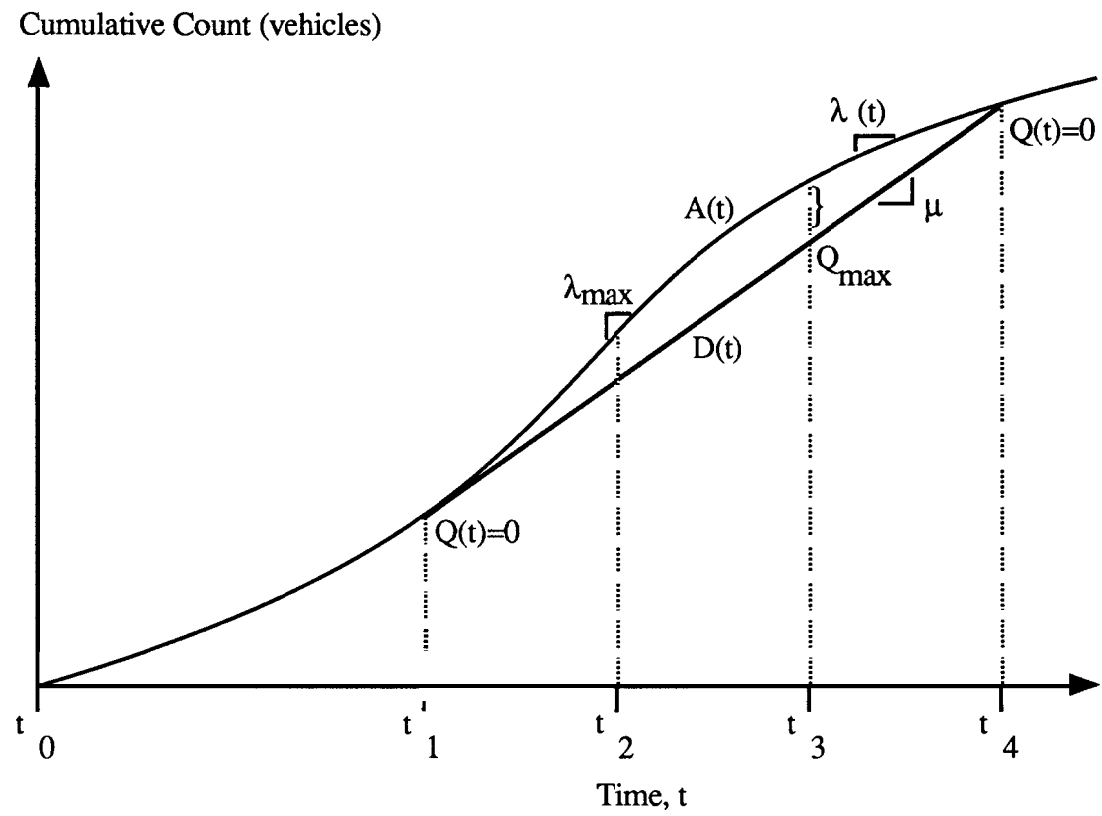

Figure 5.15. Cumulative curves for a quadratic arrival rate.

The market level, m , is in lean vehicles per peak period, and N_A is the number of automobiles to arrive during the peak period (subscript A refers to automobiles, and subscript L refers to lean vehicles).

$$N_A = \lambda_A(t_{4A}) - \lambda_A(t_{1A}) = \mu_A (t_{4A} - t_{1A}) \quad (5.11)$$

According to (5.1) and (5.10) the maximum arrival rates for both lean vehicles and automobiles will occur at the same time ($t_{2A} = t_{2L}$). Combined with (5.2), this gives the relationship between the arrival curve shape factors.

$$\beta_L = \frac{m}{N_A} \beta_A \quad (5.12)$$

Thus, the arrival curve for lean vehicles during the peak period would be proportional to the curve shown in Figure 5.15.

The capacity of a lane with lean vehicles only (driving single file) would be about 2260 vehicles per hour (vph), an increase of 13% (from Appendix B). If lean vehicles could drive side-by-side in a shared lane the capacity would be 4520 vph for 100% lean vehicles, which is the same as for two exclusive lanes. Thus, the capacity of a roadway with lean vehicles can be expressed as

$$\mu_L \left[\frac{\text{lean vehicles}}{\text{hour}} \right] = 2260 i, \quad (i = 1, 2, \dots) \quad (5.13)$$

where i is the number of effective lanes. Any time savings provided by the lean vehicles would depend on whether the lanes were shared or exclusive, as discussed below .

Time Savings - Exclusive Lanes

The time savings calculations are based on several assumptions. All vehicles are assumed to travel at the **freeflow** velocity without delay when there is no queueing. When the demand exceeds capacity there is a queueing delay at the entrance to the bottleneck, and vehicles are assumed to travel through the bottleneck at the capacity velocity. As a result, time savings occur only during peak periods when there is queueing.

A general equation for the time savings benefit, $B_x^T(m)$, which applies to both exclusive and shared lean vehicle lanes can be expressed as

$$B_x^T(m) = N \left[\left(\frac{W_A}{N_A} \right) m - W_L(m) \right] c_T + N_Q \left(\frac{1}{v_c} - \frac{1}{v_f} \right) L_B c_T [m - N_D(m)] \quad (5.14)$$

where $W_L(m)$ and $N_D(m)$ are different for shared and exclusive lanes, as discussed below.

The first term in (5.14) represents the time saved in the queue at the entrance to the bottleneck. N_Q is the number of days per year with queueing, and c_T is the dollar value of time saved. The total delay for automobiles in existing lanes and for lean vehicles in exclusive lanes can be calculated by substituting the appropriate parameters into (5.9).

$$W_A = \begin{cases} 0, & \lambda_A(t_{2A}) \leq \mu_A \\ \frac{9 \{ \lambda_A(t_{2A}) - \mu_A \}^2}{4 \beta_A}, & \lambda_A(t_{2A}) > \mu_A \end{cases} \quad (5.15)$$

$$W_L(m) = \begin{cases} 0, & \lambda_L(t_{2L}) \leq \mu_L \\ \frac{9 \{ \lambda_L(t_{2L}) - \mu_L \}^2}{4 \beta_L}, & \lambda_L(t_{2L}) > \mu_L \end{cases} \quad (5.16)$$

Combining (5.10), (5.12), and (5.16) gives us the total lean vehicle delay for exclusive lanes in terms of known parameters.

$$W_L(m) = \begin{cases} 0, & m \leq \frac{N_A \mu_L}{\lambda_A(t_{2A})} \\ \frac{9 N_A \left[\left(\frac{\lambda_A(t_{2A})}{N_A} \right) m - \mu_L \right]^2}{4 \beta_A m}, & m > \frac{N_A \mu_L}{\lambda_A(t_{2A})} \end{cases} \quad (5.17)$$

The second term in (5.14) represents the time saved by lean vehicles which are not delayed and are thus able to travel the length of the bottleneck, L_B , at freeflow speed, v_f ,

instead of capacity speed, v_c . $N_D(m)$ is the number of lean vehicles delayed at the bottleneck.

$$N_D(m) = \mu_L (t_{4L} - t_{1L}) \quad (5.18)$$

Using (5.5), (5.6), (5.10), (5.12), and (5.18) we get the final expression for $N_D(m)$ for exclusive lanes.

$$N_D(m) = \begin{cases} 0, & m \leq \frac{N_A \mu_L}{\lambda_A(t_{2A})} \\ 3 \mu_L \left[\frac{\lambda_A(t_{2A}) - \left(\frac{N_A \mu_L}{m}\right)}{\beta_A} \right]^2, & m > \frac{N_A \mu_L}{\lambda_A(t_{2A})} \end{cases} \quad (5.19)$$

Time Savings - Shared Lanes

Time savings are not included for shared lanes because any capacity increase provided by lean vehicles is assumed to be absorbed either by more automobiles or more lean vehicles. Thus, shared lanes are assumed to operate at capacity during the peak period regardless of the fraction of lean vehicles.

As a result, the average delay for lean vehicles is the same as the average delay for automobiles, even though the throughput increases, until the market level is such that all vehicles in the shared lanes are lean vehicles. At that point, if the capacity for 100% lean vehicles is exceeded, the delay becomes worse than in the original situation. This can be considered as a time penalty that appears at high market levels which causes the benefit to decrease and allows calculation of upper market limits for shared lanes.

Thus, the delay for shared lanes is given by

$$W_L(m) = \begin{cases} \frac{W_A m}{N_A}, & \lambda_L(t_{2L}) \leq \frac{\mu_L \lambda_A(t_{2A})}{\mu_A} \\ \frac{9 \{ \lambda_L(t_{2L}) - \mu_L \}^2}{4 \beta_L}, & \lambda_L(t_{2L}) > \frac{\mu_L \lambda_A(t_{2A})}{\mu_A} \end{cases} \quad (5.20)$$

where the transition occurs when the delay values are equal. The transition point can be found using (5.10) with the inequalities in (5.20).

$$\frac{m}{\mu_L} = \frac{N_A}{\mu_A} \quad (5.21)$$

Substitution gives the final expression for total delay to lean vehicles in shared lanes.

$$W_L(m) = \begin{cases} \frac{W_A m}{N_A}, & m \leq \frac{N_A \mu_L}{\mu_A} \\ \frac{9 N_A \left[\left(\frac{\lambda_A(t_{2A})}{N_A} \right) m - \mu_L \right]^2}{4 \beta_A m}, & m > \frac{N_A \mu_L}{\mu_A} \end{cases} \quad (5.22)$$

For shared lanes the number of lean vehicles delayed at the bottleneck, $N_D(m)$, is

$$N_D(m) = \text{maximum}\{ m, \mu_L(t_{4L} - t_{1L}) \} \quad (5.23)$$

which, combined with (5.5), (5.6), (5.10) and (5.12), gives the final expression for $N_D(m)$ for shared lanes.

$$N_D(m) = \begin{cases} m, & m \leq \frac{N_A \mu_L}{\mu_A} \\ 3 \mu_L \left[\frac{\lambda_A(t_{2A}) - \left(\frac{N_A \mu_L}{m} \right)}{\beta_A} \right]^{\frac{1}{2}}, & m > \frac{N_A \mu_L}{\mu_A} \end{cases} \quad (5.24)$$

Fuel Savings

The fuel savings benefit consists of a running fuel component and an idling fuel component. Running fuel savings is the result of the higher “miles per gallon” (mpg) rating of lean vehicles. The running fuel savings benefit, $B_x^F(m)$, in dollars per year is given by

$$B_x^F(m) \left[\frac{\$}{\text{yr}} \right] = 365 \text{ AADT} \left(\frac{1}{e_A} - \frac{1}{e_L} \right) L_B c_G \frac{m}{N_A} \quad (5.25)$$

where AADT is the average annual daily traffic at the bottleneck, c_G is the cost of gasoline, and e_A and e_L are the fuel economy (mpg) ratings of automobiles and lean vehicles, respectively.

Idling fuel savings is the result of smaller engines which burn less fuel during idle than large engines. The idling fuel savings benefit, $B_x^I(m)$ is given by

$$B_x^I(m) = N_Q \left[g_A \left(\frac{W_A m}{N_A} \right) - g_L W_L(m) \right] c_G \quad (5.26)$$

where g_A and g_L are the fuel consumption rates for automobiles and lean vehicles, respectively. The idling time (or delay) for lean vehicles, $W_L(m)$, is given by (5.17) for exclusive lanes and (5.22) for shared lanes.

Benefit Curves

The total benefit, $B,(m)$, is the sum of the individual components, according to (3.2).

$$B,(m) = B_x^T(m) + B_x^F(m) + B_x^I(m) \quad (5.27)$$

The time, running fuel, and idling fuel components are from (5.14), (5.25), and (5.26), respectively. It should be noted that running fuel savings are proportional to the bottleneck length, but idling fuel savings are proportional to the number of bottlenecks (which is “one” in this case). Time savings depends on both the number of bottlenecks and their lengths.

The reference situation is a one-mile bottleneck with three standard lanes in each direction (all values discussed below refer to one direction only). The benefits were calculated based on the highway parameters in Table 5.2, which represents an evening peak period where queueing begins at 4 pm and ends at 7 pm, and the fuel parameters in Table 5.3. Each direction of the bottleneck is assumed to have only one peak period during each working day (250 working days per year). The average annual daily traffic (AADT) is 50,000 vehicles per day per direction, and the capacity of the existing road is 6000 vph or

Table 5.2 Highway Parameters for Benefit Calculations

Parameter	Value	Symbol
Freeflow speed	50 mph	v_f
Speed at capacity	30 mph	v_c
Bottleneck length	1 mile	L_B
Bottleneck width (each direction)	52 feet	
Lane width (3 lanes)	12 feet	
Shoulder width (both sides)	8 feet	
Lane capacity (automobiles)	2,000 veh/hour	$\mu_A/3$
Roadway capacity (each direction)	6,000 veh/hour	PA
AADT (each direction)	50,000 veh/day	AADT
Number of days with queueing	250 days/year	N_Q
Value of time savings	\$10/hour	c_T
Arrival curve shape factor	800 veh/hour ³	PA
Maximum arrival rate	6800 veh/hour	$\lambda_A(t_{2A})$
Time of maximum arrival rate	5 PM	t_{2A}
Time queue begins	4 PM ^a	t_{1A}
Time of maximum queue	6 PM ^a	t_{3A}
Time queue ends	7 PM ^a	t_{4A}
Maximum queue	1067 vehicles ^a	Q_{max}
PM peak traffic (peak direction)	18,000 veh/peak ^a	N_A
Total delay (peak direction)	1800 vehicle-hours ^a	W_A
Average delay (per vehicle)	0.1 hours (6 minutes) ^a	w_A

^a These values are derived from the parameters above.

Table 5.3 Fuel Parameters for Benefit Calculations

Parameter	Basis	Estimate	Symbol
Automobile & light truck fuel economy	26 mpg ^a	25 mpg	e _A
Lean vehicle fuel economy	100-150 mpg ^b	100 mpg	e _L
Automobile idling fuel consumption	0.8 gallons/hr ^c	0 . 6 gallons/hr	g _A
Lean vehicle idling fuel consumption	1/2 auto rate ^d	0 . 3 gallons/hr	g _L
Gasoline price	Current	\$1 SO/gallon	c _G

^a Oak Ridge National Laboratory [ORNL, 1986, Tables 1 and 20] gives 11 million new autos at 28 mpg and 4.5 million new light trucks at 21 mpg.

^b Estimates for G.M. Lean Machine. Low estimate is used for calculations.

^c Raus [1981] gives 1.3 mpg at 1 mph for autos. Newer cars are more efficient.

^d Rate depends on engine size but not vehicle size.

2000 vph per lane. The maximum arrival rate is 6800 vph at 5 pm and the maximum queue is 1070 vehicles at 6 pm, resulting in an average delay of 6 minutes for vehicles between 4 and 7 pm.

The yearly benefits of a one-to-one shared lane and a two-to-one shared lane are shown in Figures 5.16 and 5.17, respectively. The total benefit consists of a running fuel component (labeled “fuel”) and an idling fuel component (labeled “idle”). The benefit decreases sharply as the “time penalty” takes effect when the demand exceeds the capacity with 100% lean vehicles.

The yearly benefits of one and two exclusive lanes, shown in Figures 5.18 and 5.19, respectively, include time savings because these lanes would not be congested until large numbers of lean vehicles use them. As a result, the benefit of exclusive lanes is about a factor of 5 higher than for shared lanes with the same number of lean vehicles. These benefit charts apply to all exclusive lane technologies.

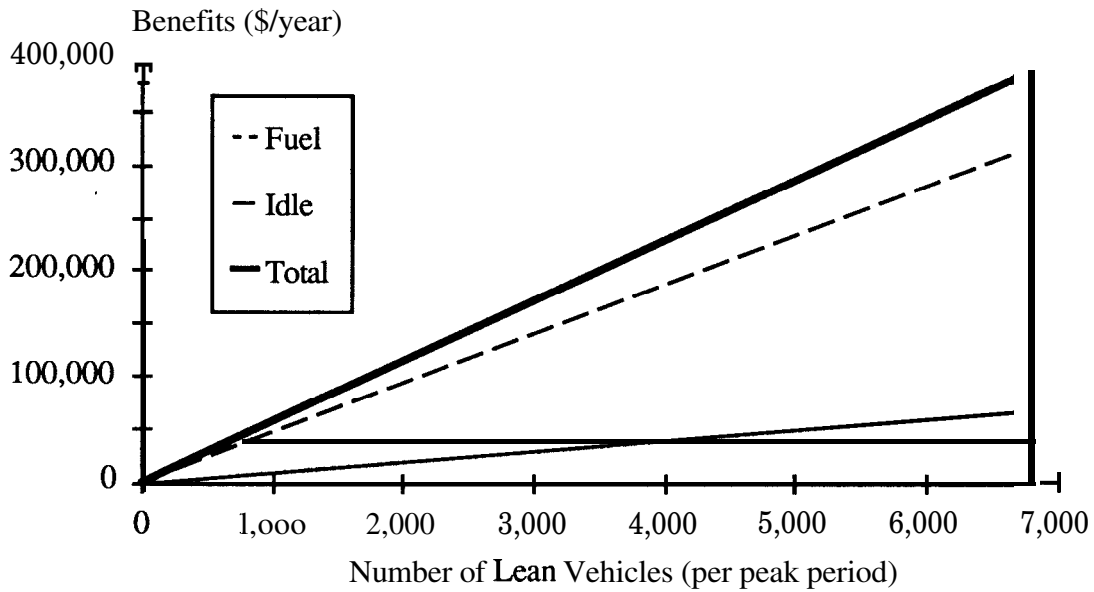

Figure 5.16. Benefits of a one-to-one shared lane.

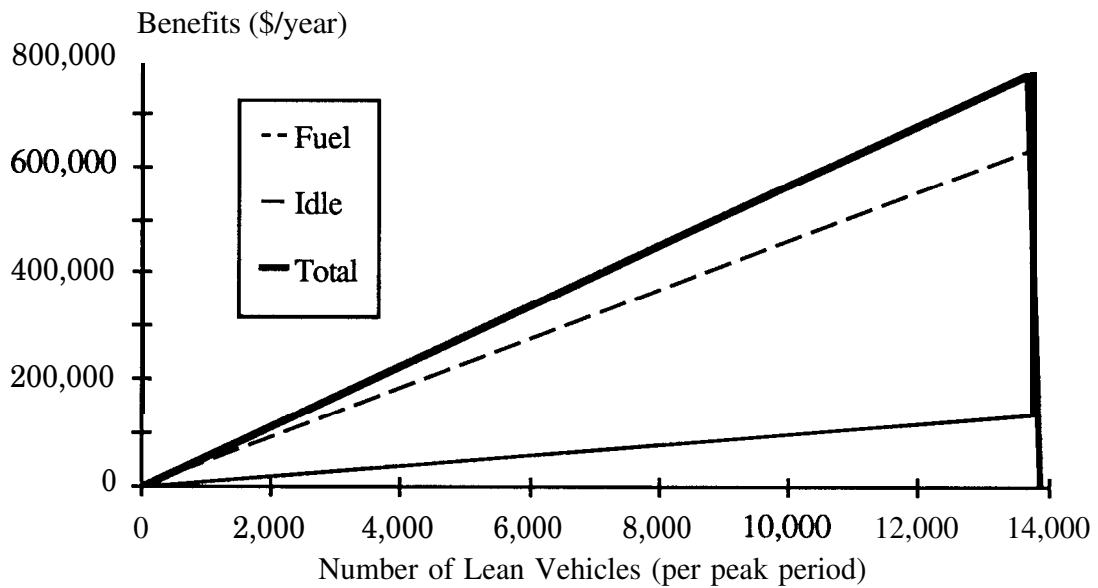

Figure 5.17. Benefits of a two-to-one shared lane.

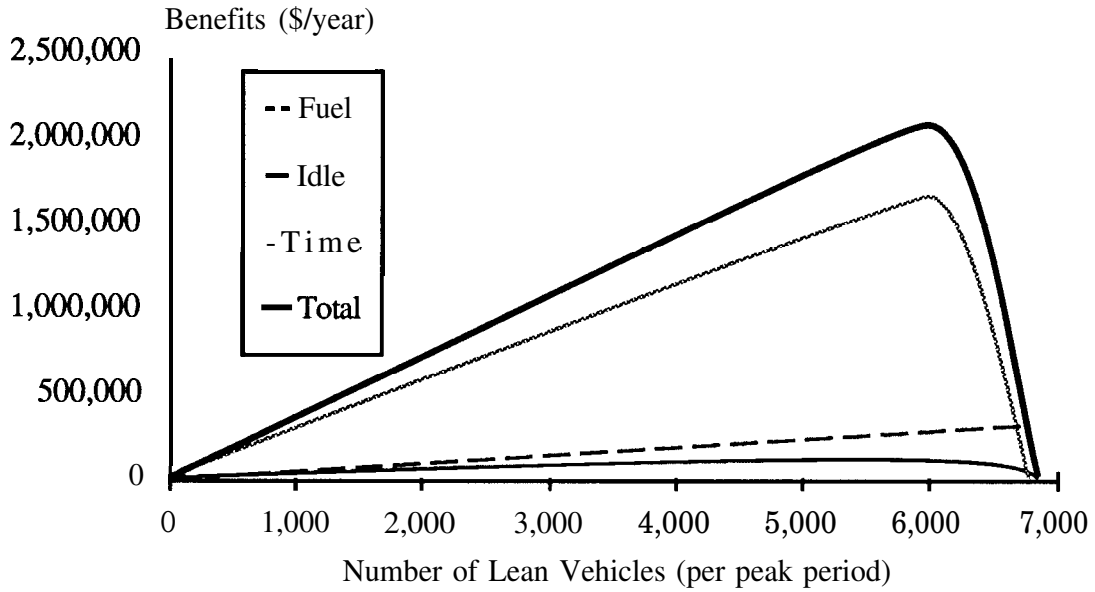

Figure 5.18. Benefits of one exclusive lane.

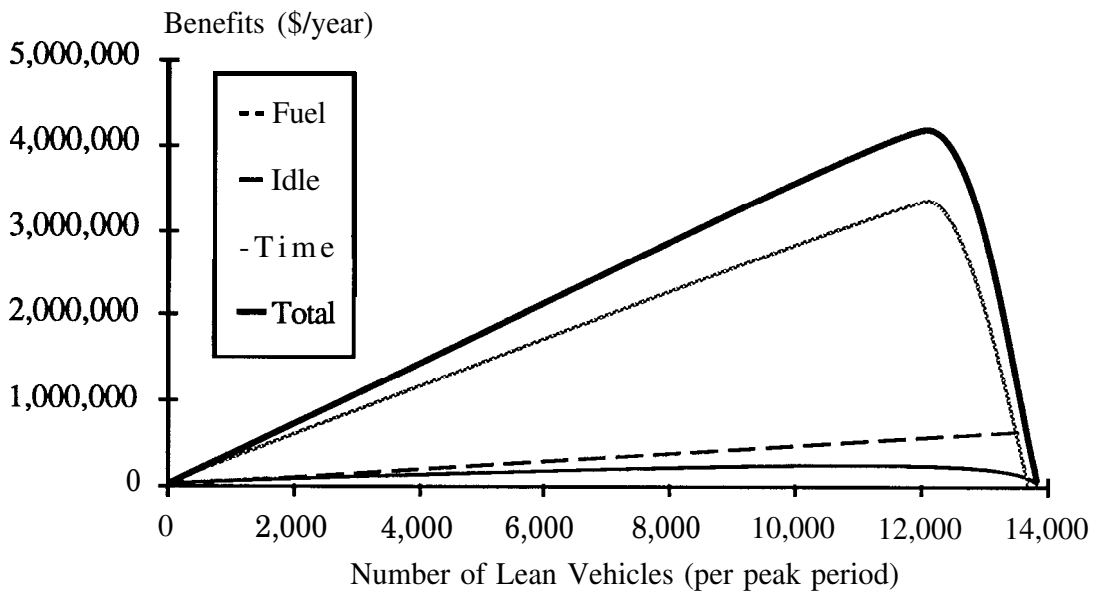

Figure 5.19. Benefits of two exclusive lanes.

Table 5.4 Unit Cost Estimate for Special Lane Development

<u>Component</u>	<u>Cost (per month)</u>
2 Senior engineers @\$5,000/mo	\$10,000
5 Junior engineers @\$3,000/mo	\$15,000
10 “Workers” @\$3,000/mo	<u>\$30,000</u>
Total Labor	<u>\$55,000</u>
Equipment	\$30,000
Test site	\$100,000
Materials	<u>\$15,000</u>
Total Capital	<u>\$145,000</u>
Total Labor and Capital	<u>\$200,000</u>

5.3.2. Costs

Unit cost estimates for development activities are shown in Table 5.4, and those for implementation and market growth activities are shown in Table 5.5. Activity time and cost estimates are summarized in Table 5.6 for the highway activities diagrammed in Figure 5.10 (see Appendix C for a sample cost estimate). The implementation costs are given on a per year basis, obtained by dividing each component cost by its expected useful lifetime. Implementation costs are based on the assumption that any existing lane or shoulder would have to be resurfaced before it could be used by lean vehicles in order to fill potholes, patch uneven areas, and smooth transitions at joints and edges.

The yearly operation and maintenance costs for the market growth activities are included because they are significant for highway modifications (compared to parking modifications), except for the shoulder and edge exclusive lanes which are not expected to add to current maintenance requirements. The minimum development time is expected to

Table 5.5 Unit Cost Estimates for Road Modifications

Description	Cost Basis	Cost Estimate	Lifetime Estimate
Stripe removal (6' thermoplastic)	\$1.50/ft ^a	\$5,000/mi	10 years
Stripe addition (6" thermoplastic)	\$0.60/ft ^a	\$2,500/mi	5 years
Sign installation	\$2 10 each ^b	\$1,000/mi (-4 signs)	5 years
Resurfacing	\$5,000/ft-mi ^b	\$5,000/ft-mi	Shared - 5 years Exclusive - 10 years
New lanes (existing R.O.W.)	\$10,600/ft-mi ^c	\$10,000/ft-mi	10 years
Elevated lanes & flyovers	\$19/sq ft ^d	\$30/sq ft	20 years
Road maintenance	\$250/ft-mi-yr ^b	\$250/ft-mi-yr	1 year
Convertible lane signals	\$100,000 per intersection ^b	\$100,000/mi (4 signals)	10 years
Signal maintenance	\$1,000/signal-yr ^e	\$4,000/mi-yr	1 year
Changeable message sign (CMS)	\$100,000 each ^f	\$1 00,000/direc tion	10 years
CMS maintenance	\$3,400/sign-yr ^f	\$3,400/direction-yr	1 year
Closed circuit television (CCTV)	\$27,000/camera ^f	\$27,000/direction	10 years
CCTV maintenance	\$2,300/camera-yr ^f	\$2,300/direction-yr	1 year
Moveable barriers for reversible lanes		\$8,000/direction-yr ^g	1 year

^a Edwards and Kelcey [1978, p. 5-25].

^b Transportation Research Board [TRB, 1987, pp. 120-127].

^c Value given is for shoulder widening [TRB, 1987, p.127].

^d Bagon [1980]. Compare to \$56-106/sq ft for bridges [TRB, 1987, p. 122].

^e Value given is for a pedestrian signal [JHK & Associates, 1985, p. 35].

^f Kostyniuk et al. [1988, pp. 102-104].

^g Based on 2 men, 1 hour/direction-day, 250 days/year, \$16/hr.

Table 5.6 Activity Time and Cost Parameters for Special Lanes

Technology (x)	Development		Implementation		Market Growth
	Time	Cost (\$)	Time	Cost (\$/yr) ^a	Cost (\$/yr) ^a
	T^D_x	C^D_x	T^I_x	C^I_x	C^M_x
One-to-one (0)	2 m	400,000	1 m	13,200	3,000
Two-to-one (t)	3 m	600,000	0.5 m	700	3,000
Convertible (c)	3 m	600,000	1 m	7,000	3,000
Shoulder (s)	1 m	200,000	1 m	4,200	0
Exclusive (e)	1.5 m	300,000	1.5 m	6,200	0
Elevated (l)	2 m	400,000	3 m	80,000	2,500
New road (n)	2.5 m	500,000	2.5 m	11,200	2,500
Reversible (r)	4 m	800,000	1 m	12,700	16,200
Lane width (w)	1 m	200,000		-	-
Geometry (g)	2 m	400,000	-	-	-
Structure (u)	2 m	400,000	-	-	-
Flyover (f)	3 m	600,000			-

^a Implementation and market growth costs are per application.

Table 5.7 Market Ranges for Special Lanes - Strategy 0

Technology (x)	Lean Vehicles (per peak period)		
	Lower limit	Upper limit	First application
	L_x^0	U_x^0	F_x^0
One-to-one (o)	280	6900	1690
Two-to-one (t)	300	13700	4500
Convertible (c)	6000	13700	6000
Shoulder (s)	12	6900	240
Exclusive (e)	18	6900	270
Elevated (l)	240	6900	520
New road (n)	39	6900	350
Reversible (r)	114	13700	650

be on the order of one month, and the minimum implementation time about the same, except for the two-to-one concept which simply adds to the work done for the one-to-one concept.

5.3.3. Market Ranges

The resulting market ranges for the various special lane technologies are given in Table 5.7 for Strategy 0: each technology is considered independently (see Appendix C for sample calculations). All of the lower limits are fairly low on a percentage of total cost basis (except for the convertible lane technology). Even if all of the cost components were doubled, the lower limits would only be doubled and they would still be fairly low. Thus, the general conclusion, that these technologies could be cost effective at low market levels, is not highly dependent on the accuracy of the estimates.

The lower limits for all of the exclusive lane technologies are less than the lower limits for all of the shared lane technologies. This is somewhat surprising but is the result of time savings benefits and longer facility lifetime for exclusive lanes. It must be realized that even though the lower limits are lower, the exclusive lane concepts cost much more to implement on a total cost basis (as opposed to the cost per year basis shown in Table 5.6) compared to shared lanes. Thus, the potential risk of developing and implementing any exclusive lane concept would be higher than for a shared lane concept. This might lead facility suppliers to choose to develop and implement shared lane concepts first, in order to test the market. Unfortunately the shared lane concepts are not as desirable for lean vehicle users, which could result in slow or negligible market growth. (This situation can be compared to implementation of high-occupancy vehicle [HOV] lanes.)

The first application limits were derived by converting all necessary development costs to a yearly amount based on the lifetime of the technology in question. In all cases the first application limits are less than the appropriate upper (physical) limits. Again, the first application limits for the shared lane technologies are much higher. The lower limit and first application limit for the convertible lane technology is 6000 lean vehicles per peak period, which is not from a benefit/cost basis but because 6000 automobiles would be displaced during the three-hour peak period by this technology.

5.4. SPAN Diagrams

The scaled precedence activity network (SPAN) diagram for the highway bottleneck situation is shown in Figures 5.20 and 5.21 for Strategy 0. This diagram has been split into two parts, one for shared lane technologies and one for exclusive lane technologies since there are too many activities to represent clearly in one figure. However, the diagrams have the same scale (so they can be superimposed if necessary) and they each include all the necessary development activities.

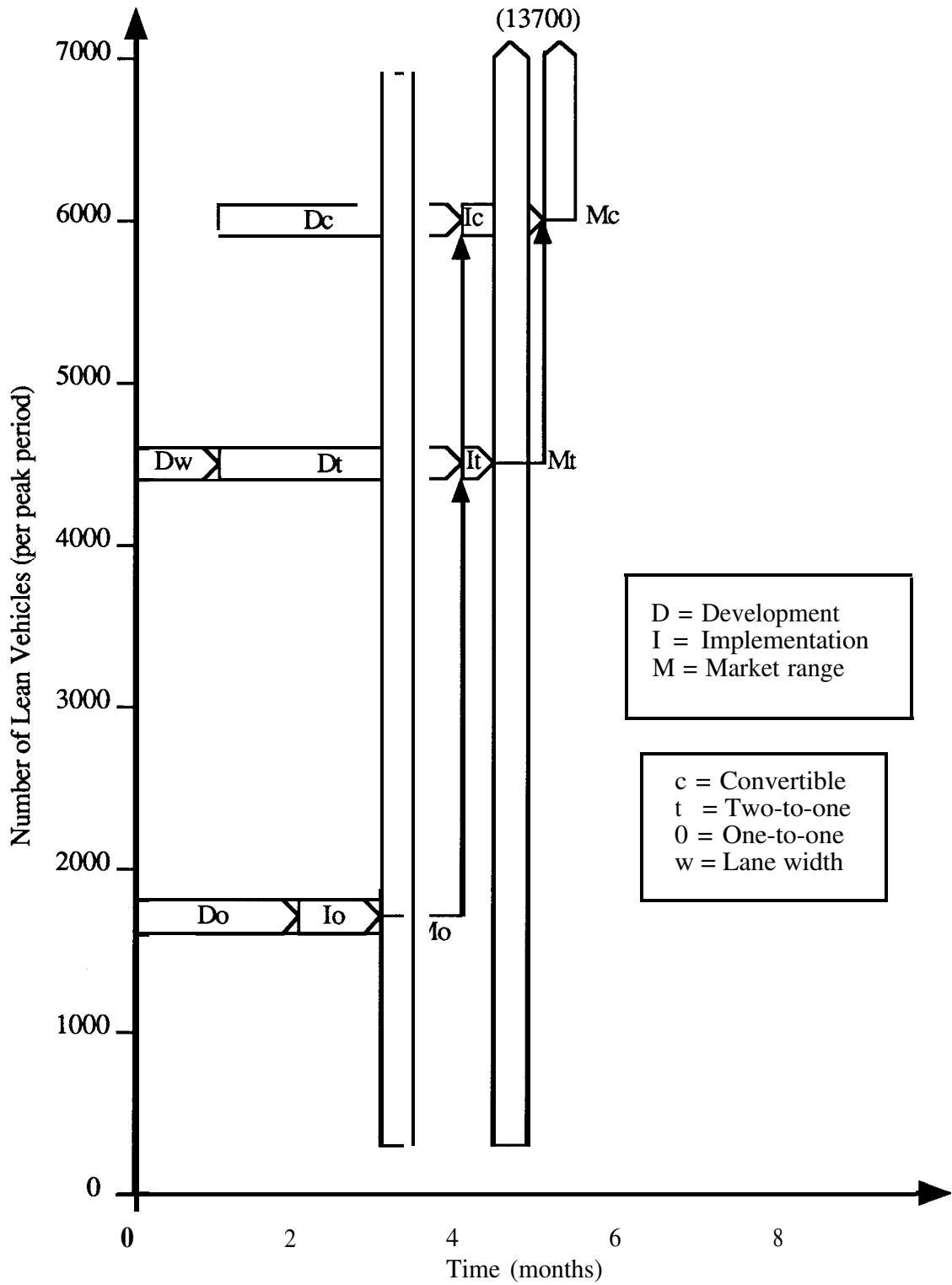

Figure 5.20. Highway SPAN diagram (shared lane technologies) - Strategy 0.

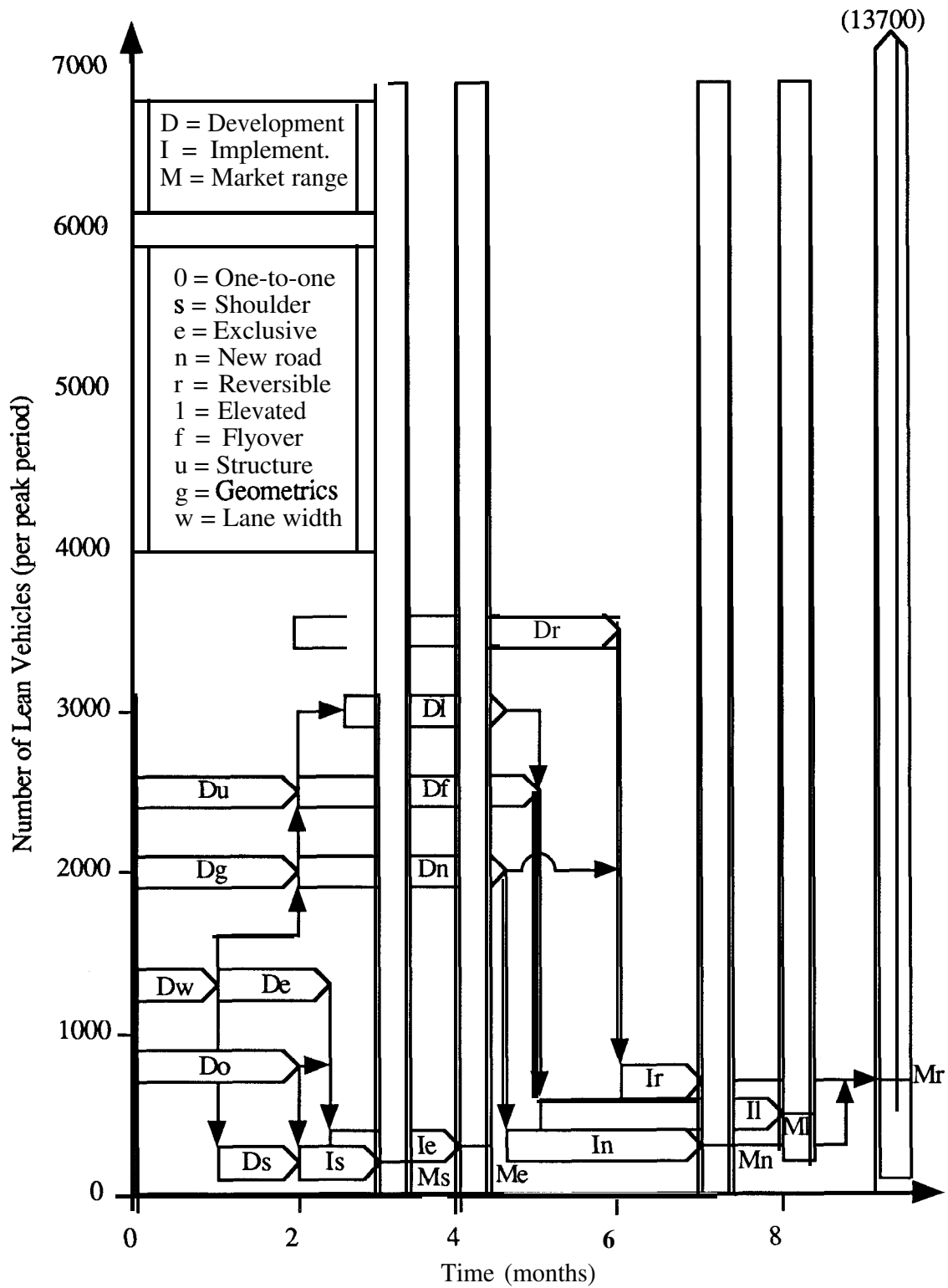

Figure 5.21, Highway SPAN diagram (exclusive lane technologies) - Strategy 0.

Three logical alternative strategies can be identified from the highway activity networks. The **first** strategy includes only the shared lane technologies and the convertible lane technology (which is sort of a hybrid). This strategy assumes that there is no room for either shoulder, edge, or median exclusive lanes. Also, it is assumed that a special lane is desired before elevated lanes can be developed. Thus, Strategy 1 involves implementing the one-to-one concept first because it can be developed and has the lowest lower limit of the three technologies (because it is the least expensive). Remember that the other two concepts have to implement the one-to-one technology before they can operate. The **two-to-one** concept would then be implemented as soon as it is developed, or as soon as enough lean vehicles use the lane to cover the cost of implementing both technologies, whichever comes later. Then, when the market reaches 6000 lean vehicles per peak period (if ever), or when the convertible concept is developed, the convertible concept would be implemented.

Strategy 2 assumes that shared lanes are undesirable, either for safety or economic reasons, and that there is enough shoulder and median space for exclusive lanes. However, the shoulder lane will only be used until a new median lane can be developed and implemented, or until the traffic can support the new median lanes. Eventually, the traffic might exceed the capacity of the single new median lane in each direction, and the reversible concept could be implemented to operate both new median lanes in the peak direction. The lean vehicle traffic in the off-peak direction could use the shoulder lane during peak periods. It would be unwise to allow excess peak direction lean vehicle traffic to use the shoulder (in the absence of reversible lanes) because approximately half of the lean vehicle traffic would choose to use the shoulder lane, which would prohibit the use of the shoulder by automobile and truck traffic. This is not expected to be as much of a problem in the off-peak direction because there is presumably excess capacity in the standard lanes.

Table 5.8 Market Ranges for Special Lanes - Other Strategies

Technology (x)	Lean Vehicles (per peak period)		
	Lower limit L_x^j	Upper limit U_x^j	First application F_x^j
Strategy 1 (i = 1)			
One-to-one (o)	280	300	1690
Two- to-one (t)	300	6000	4500
Convertible (c)	6000	13700	6000
Strategy 2 (i = 2)			
Shoulder (s)	12	51	240
New road (n)	51	6900	540
Reversible (r)	7000	13700	7200
Strategy 3 (i = 3)			
Exclusive (e)	18	260	270
Elevated (1)	260	6900	760

Strategy 3 also assumes that shared lanes are undesirable, but that there is no room for shoulder or median exclusive lanes. This strategy uses an edge exclusive lane, created by carving out space by restriping existing lanes, until an elevated facility can be developed and implemented, or until the traffic can support the elevated lanes. The edge exclusive lane would then be closed and used as a shoulder, or the roadway could be restriped to its original form. The previous caveats regarding use of this edge exclusive lane for spillover from the elevated lane also apply here.

Market ranges for Strategies 1, 2, and 3 are given in Table 5.8, and SPAN diagrams, with development activities, are shown in Figures 5.22 through 5.24. The first application limits were calculated on the same basis as those for the parking modifications. The **first** application limits are generally less than the upper limits except for the first technology in each strategy. However, all first application limits are still below the upper (physical) limits from Strategy 0.

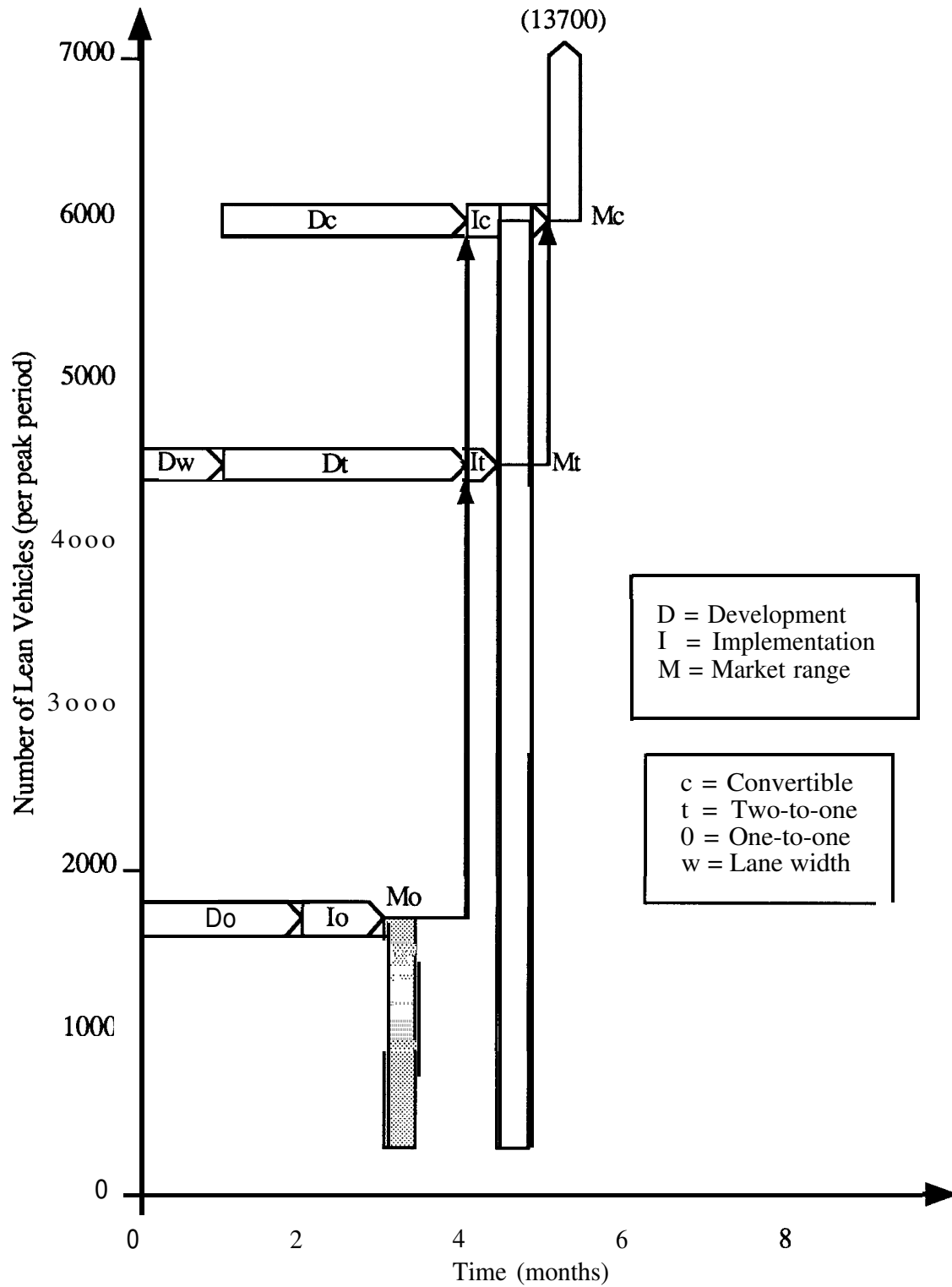

Figure 5.22. Highway SPAN diagram - Strategy 1.

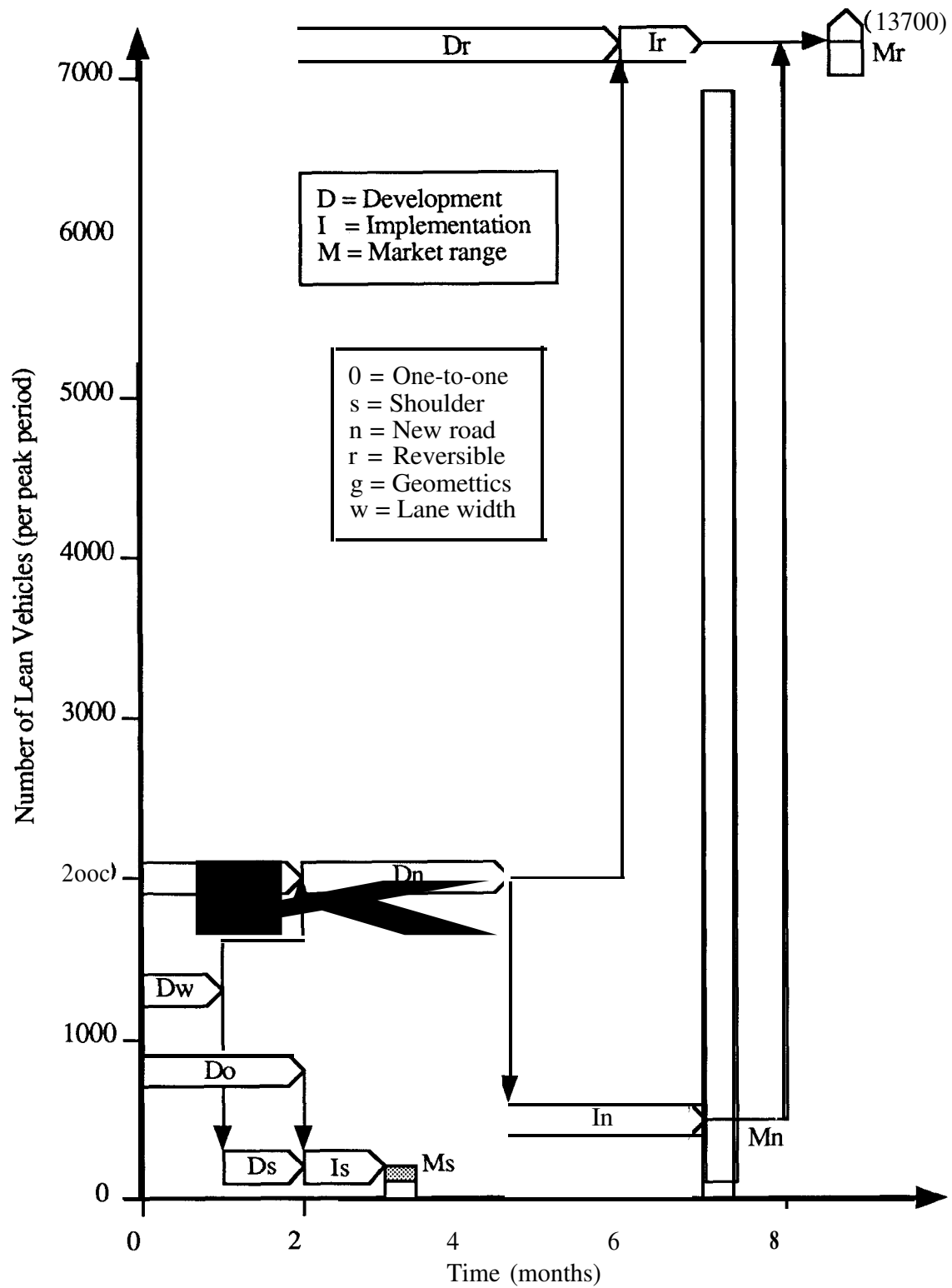

Figure 5.23. Highway SPAN diagram - Strategy 2.

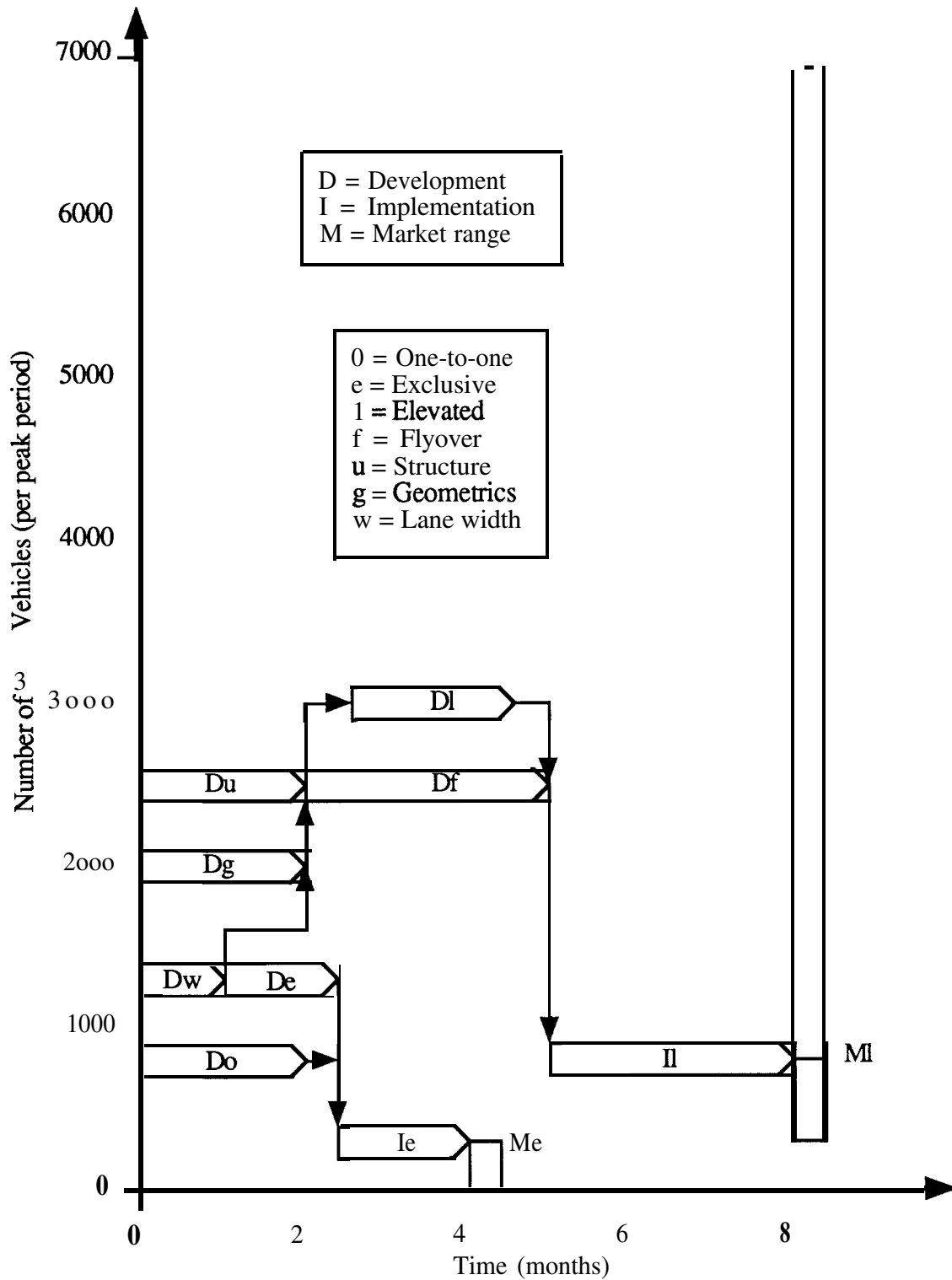

Figure 5.24. Highway SPAN diagram - Strategy 3.

6. SUMMARY AND CONCLUSIONS

6.1. Summary

This research addresses the question of how to redesign the current automobile/highway (and parking) system in order to accommodate and encourage the adoption and use of lean vehicles. We seek a gradual transition from the existing system to an alternative system instead of an “all-or-nothing” approach. History shows us that new systems are built in large part from old things, and that successful transportation systems evolved to fit the time and place. They were not designed in their final form at the beginning. Traditional engineering/system design was not used and would not alone be appropriate for designing future transportation systems. It is more appropriate to combine some ideas from engineering/system design with some design ideas from other fields. The ideas of design evolution, self-designing systems, and activity networks seem to be the most useful for improving the design process. The first two ideas help explain the process of design and set the context within which transportation system design must operate. The further objective of this research is to speed introduction and transition compared to evolutionary change.

Activity networks are tools which help to improve the design process by identifying technologies and pathways with low transition costs. Facility designers need to estimate the conditions under which a particular technology will be favorable and how long it will take to develop and implement. In order to have the right facilities in the right place at the right time, they must also know how each technology depends on previous technologies. This allows them to determine which technologies must be developed now and which can wait until later.

The research explores existing activity network techniques and combines them with new and modified techniques into a package which can be used to design systems for lean vehicles and other transportation systems. The activity network design approach should be

useful not only to facility suppliers, but also to vehicle suppliers trying to decide whether or not to produce the required vehicles, and to intermediaries trying to decide which actions to take in order to enable or accelerate alternative designs.

The study investigates the use of activity networks as a tool for designing a system of parking and road facilities for lean vehicles. A system for lean vehicles must evolve over time and coexist (at least initially) with other transportation systems, since it does not exist today and a complete and separate system cannot be implemented immediately. The procedure is to identify potential concepts for modification of facilities, construct a basic activity network of the necessary activities, estimate the time, cost, and resources required for each activity, and then calculate the appropriate market range for each concept. These estimates and calculations are site specific and depend on a number of assumptions.

Results are presented graphically in the form of scaled precedence activity network (SPAN) diagrams, which can be drawn and interpreted in a number of ways. Several alternative implementation strategies are then identified from the graphical results, and these strategies are also represented graphically. Strategies are selected on the basis of matching the level of deployment of facilities with the number of lean vehicles in the market. These implementation strategies provide a means of transition to lean vehicle systems without large initial investments.

6.2. Conclusions

6.2.1. Results

Results from the lean vehicle analysis are encouraging, even considering the limited accuracy of the time and cost estimates. The lower market limits for nearly all technologies are quite low on a percentage of total traffic basis, and they would still be low even if the cost estimates were doubled.

The results for modifications to road facilities are particularly interesting. Shared lean vehicle lanes take less time to develop and cost less to implement than exclusive lanes,

which might initially tempt facility suppliers to decide to deploy shared lanes **first** even though they are not as attractive to users, and the market might not ever grow enough to recover initial costs. However, the lower market range limit for exclusive lanes is much less than the lower limit for shared lanes because of the higher potential benefit of exclusive lanes. Thus, the facility supplier might reconsider what types of lanes to deploy initially. The dilemma might not be obvious from the outset, but the activity network approach allows the facility supplier to compare the options both quantitatively and graphically in order to best avoid risky investment of resources.

A major difference between the use of the activity network approach for various transportation systems is the evaluation of benefits. For the lean vehicle study, fuel savings and time savings benefits were considered. Pollution reduction (air and noise) would also be a major benefit, but appropriate numbers are not available at this time. Benefits for other transportation systems would be different and might include the following components:

1. Increased safety.
2. Increased mobility (especially for the young, old, or disabled).
3. Increased accessibility (to congested or remote areas).
4. Increased level of service (comfort, convenience).
5. Reduced environmental impact (less use of resources: land, energy, materials).

Some of these benefit components might be difficult to quantify, but they could be even more important than time and fuel savings (even in the lean vehicle situation).

Furthermore, each benefit component could be evaluated in a number of different ways. For instance, the lean vehicle study used a conservative and simple approach to evaluate time savings (no time savings for shared lanes and queueing delay reduction for exclusive lanes), but many alternative methods of evaluating time savings exist. The value of time saved is the subject of much debate.

6.2.2. Limitations

The activity network approach does not address all of the issues related to initiating alternative designs like those for lean vehicles. Numerous barriers to change exist which will hinder any innovative design effort. These barriers include potential disbenefits of introducing lean vehicles (the opposites of the benefits listed above) which might not be additive even if they are quantifiable. For instance, a perceived decrease in safety might have a psychological multiplier which would allow it to negate potential benefits which are even larger.

Another barrier is system inertia. Care must be taken to choose technologies which will be enabled, not prevented, by the flow of benefits and costs to those actors that control decisions. Otherwise, methods must be devised to alter the flow of benefits and costs: a tricky business.

Furthermore, it is unlikely that any one organization exists which could orchestrate all the changes in the desired fashion. As mentioned in Chapter 1, there are many actors involved in the design process, and the effectiveness of any actions taken by facility designers/suppliers will depend on the actions of other actors. However, the activity network approach does outline the possible design paths and allows the actors to choose the paths that they can strive to achieve.

6.2.3. Relation to Highway Funding Programs

The Federal Highway Administration's proposed 1991 Surface Transportation Act recognizes the need for innovative highway developments. It proposes an Urban-Rural Program with 60% federal and 40% local funding which will contain special "bonus" treatment for innovative approaches to problems of air pollution, congestion, and/or rural access. The bonus treatment might involve increased federal matching of costs and/or additional funds over and above those appropriated by formula. The lean vehicle concept and design approach might benefit from this special treatment.

However, the proposed legislation will not make funds available for urban local roads or rural minor collectors. This could limit the availability of funds for certain facility adjustments that might be needed to accommodate lean vehicles.

6.3. Further Research

As usual, this research leaves some questions unanswered. Some of those questions might be answered by extensions to the activity network approach, and others might require additional research regarding the lean vehicle design process which is outside the realm of activity networks.

6.3.1. Extensions

Calculations were performed for all the parking situations and for the highway situation but not for other road situations (arterials, intersections, and interchanges). Any market study or site specific study would require a combination of the above results with results from calculations for arterials, intersections, and interchanges. Calculations for those situations, as well as the calculations for the parking and highway situations, would benefit from improved input data. Improved estimates of costs and times for various activities should be available from facility suppliers and constructors. Actual operating data (especially capacities and time dependent traffic volumes) along with lean vehicle operating parameters (such as fuel consumption and pollution emission rates) would help improve the benefit calculations.

Some of the limitations mentioned in the section above could be partially resolved by using expanded network representations of the major activities combined with other activity network techniques discussed in Chapter 2. An expanded network representation of the development phase using probabilistic branching and looping could incorporate the “planning” process. This planning process would not include those activities needed to implement a specific technology in a specific location, but rather those activities which lead

to investigation of lean vehicle technologies and systems. Those activities might describe what is necessary to go over or around the barriers mentioned above.

Subnetworks for all three major activities (development, implementation, market growth) could be created and might include statistical distributions of parameters, lag and/or overlap of activities, and probabilistic branching and looping. Of course, any of those techniques could be added to the major activity networks, but the networks would then be difficult to represent with SPAN diagrams. The subnetworks would be used to find the appropriate parameter averages and distributions for the major activities using traditional activity network techniques. It might be possible to show distributions of market range limits on the SPAN diagrams using fuzzy or shaded bars, but showing time distributions for development and implementation activities would be counter productive.

Underlying the activity network approach is the idea of risk management; however, more detailed risk assessment is needed to guide decision making. Risk is minimized indirectly by avoiding large initial investments, but there is no direct measurement of risk. Adding uncertainty to time and cost estimates (using PERT or similar existing activity network techniques) might aid the process of risk assessment, but it would not be complete. There are other risks associated with the market for lean vehicles that cannot be addressed directly with activity networks.

6.3.2. Additions

Finally, what else is needed to initiate a process leading to systems for lean vehicles? We have used activity networks to represent only part of the design process: those facility related actions that take place after the transition has begun. A prior effort is needed to identify the market and initiate the transition. General Motors (GM) has identified a potential lean vehicle in the Lean Machine, and this study has identified some possible facility modifications for lean vehicles. Together, GM and the California Department of Transportation (Caltrans) are now trying to further identify a market which

they believe exists. Market studies are being conducted by Booz-Allen & Hamilton to identify who would use lean vehicles and how they would be used (commuting, service industries, neighborhood access, . . .).

Some alternative transportation systems mentioned previously are at different stages within the design process. A market for truck highways was identified as early as the 1920s, but the transition process has not yet been initiated. The transition stage for **high-speed rail** has already begun in Japan and several European countries, but the U.S. is still in the market identification stage for the most part. A market has been identified for several IVHS technologies and the transition stage has partially begun in the U.S. and other countries. However, there are many players involved in the IVHS transition and efforts may not have been well coordinated (with resulting duplication of effort and possibly effort wasted on paths that had already been rejected). The formation of the IVHS America group is intended to coordinate efforts in the U.S., and such a group would certainly benefit from the activity network approach. This introduces an important question for facility design. How do the various facility supplier agencies (on the national, state, county, and local levels) interact, and how do their interactions influence the design process?

We have not directly addressed the roles of actors other than facility suppliers and designers. What else can be done to influence users, vehicle suppliers, and intermediaries to improve the design process? A common approach to introducing innovative vehicles is to make incentive arrangements between local governments, large employers, and fleet operators. Interested communities, employers, and fleet operators have been identified for the lean vehicle study, but the transition process has not yet begun.

Other unanswered questions have to do with organization management. What type of organization is needed to successfully use the activity network approach, and how would such an organization operate? Both CPM and PERT required high quality and highly structured organizations for their introductions, but we have recognized that no one organization can control all of the activities leading to an alternative transportation system.

Perhaps what is needed is a small coordinating group which can collect and disseminate the required information (times, costs, activity networks, etc.) to the various actors involved in the lean vehicle design process. Such a group has not yet been defined or formed for the lean vehicle study, although the research effort of which this study is a part is undertaking some coordinating functions.

Any coordinating group should be integrated with the transportation agencies that design and supply the facilities. Thus, individuals in the group should have experience with activity network techniques and with transportation facilities and technologies. The group would operate using a combination of communication technologies, including: phone, electronic mail, FAX, and personal visits. They would probably need authority to initiate information acquisition from the various operating agencies.

Creation of a coordinating group should be considered part of the initiation stage of the design process, and continued support of the group (both financial and otherwise) would be a necessary part of the transition process. The coordinating group cannot possibly have control over all the various actors, but it should have regional influence. Its mission would be to present information provided by the activity network approach to various actors, showing how they might benefit from certain actions. Such information triggers the decisions to change technologies.

APPENDIX A: REVIEW OF MINICARS AND RELATED STUDIES

The G.M. Lean Machine is certainly not without precedent as either a three-wheeled or small vehicle. In fact, some of the earliest automobiles were based on three-wheeled designs, and many different three-wheeled designs were produced prior to World War II, as summarized by Posthumus [1982]. An early phase of small vehicle development occurred during the depression of the 1930s when the concern was making more affordable vehicles by scaling down conventional vehicles. A summary of these efforts is provided by Caunter [1957]; however, this phase will not be discussed here because the vehicles produced were not much different from conventional vehicles.

A second phase of small vehicle development occurred in Europe after World War II due to economic concerns. This resulted in the production of some truly unique and innovative “minicars,” which will be discussed below. This phase continued in both the United States and elsewhere during the 1970s and 1980s in response to energy and environmental concerns. The lean vehicle idea can be thought of as an outgrowth of these vehicles and the related studies, which were performed during this same period, regarding the usage of alternative automobiles.

Minicar Vehicle Development

After World War II, high costs, high taxes, and shortages of materials and gasoline combined to create incentives for producing vehicles which were extremely economical with respect to both manufacturing and operating costs. As a result, European manufacturers combined motorcycle components with newly developed engines, which were small but had high specific power output, to create a new class of “minicars” or “bubble cars,” as they were called, which were both lightweight and space efficient [Caunter, 1957, pp. 93-100].

Both three-wheeled and four-wheeled minicars were produced, and some became quite popular for a few years during the 1950s, especially in Britain and Germany. Among the three-wheeled versions were the Bond Minicar in Britain and the Messerschmitt

Kabinenroller or “Cabin Scooter” in Germany. The Bond **Minicar** had a single front wheel, but the body was shaped like that of a traditional four-wheeled British convertible [Clymer, 1957, p. 76]. On the other hand, the Messerschmitt “...whose canopy was rumoured to be identical to that of the German fighter plane made by the same company, and could be converted to such at a moment’s notice,” had two front wheels and a **bubble-shaped** cockpit [Jackson, 1979, p. 182]. The Cabin Scooter had a hinged plastic top that covered the passenger compartment which accommodated two persons in tandem [Clymer, 1957, p. 138]. They were sometimes derogatorily referred to as “Snow White’s Coffins.”

Among the four-wheeled **minicars** were the Isetta and the Goggomobil. The Italian designed Isetta was produced and distributed widely in Germany by B.M.W. [Matteucci, 1970, pp. 308-9]. The Isetta had a single “front” door and the rear wheels were set close together, giving it a three-wheeled appearance and behavior [Clymer, 1957, p. 210]. A similar vehicle was the Heinkel, built under license by Trojan of Britain [Posthumus, 1982, p. 104]. The Goggomobil, produced by Glas **Isaria** in Germany, was another popular four-wheeled **minicar**, but it was essentially a miniature version of a two-door sedan [Clymer, 1957, p.106].

These **minicars** provided the first form of individual mobility to some of the many Europeans who did not own private automobiles before the war. In Germany for instance, some of the Autobahns had been completed before the war, but the Volkswagens which were to be used on the Autobahns had not yet been built in great numbers. On the other hand, in Italy, where the weather was better, scooters made by Vespa and other companies competed with **minicars** and dominated the individual mobility market.

The economic incentives for **minicars** disappeared (for the most part) during the 1950s, and by the early 1960s few **minicars** were still in production. As people became more affluent they bought larger automobiles, which better matched the roads in the cities that were being rebuilt to accommodate (full-size) automobiles. The issue of facility design for **minicars** was not considered during this early phase of **minicar** development (nor during

the pre-World War II phase of small vehicle development for that matter) because there were never enough **minicars** to make facility design a major concern. Also, the major players in **minicar** development had been vehicle producers acting independently on their own initiative. These vehicle producers were neither interested in nor responsible for facility design.

Previous Minicar System Studies

By the late 1960s a new set of incentives for **minicars** began to emerge which prompted a series of “system” studies regarding **minicar** usage that considered both vehicle and facility design as well as control and institutional issues. The incentives for these **minicar** studies included providing alternatives to mass transit, preserving urban mobility, and later, energy usage and environmental concerns. Four of the major **minicar** system studies are the Cars for Cities study [Ministry of Transport, 1967], the **Minicar** Transit System [University of Pennsylvania, 1968], the Neighborhood Car study [Garrison and Clarke, 1977], and the Mobility Enterprise project [Doherty, Sparrow, and Sinha, 1987]. They are reviewed below because of their similarities to the lean vehicle study, which shares some of their incentives for an alternative form of automotive transportation. Some of the ideas and lessons learned from these studies (regarding facility design, operations, safety, and regulation) are discussed in the appropriate sections below and in Appendix B.

Cars for Cities

The first major **minicar** system study was the Cars for Cities study performed by the Ministry of Transport [1967] in Great Britain. This study investigated the effects of urban vehicle size and performance on congestion, parking requirements, air and noise pollution, and safety. Small three-wheeled vehicles were considered, but the study favored four-wheeled vehicles for reasons of safety, stability, and comfort. The proposed “Citycars” were small urban vehicles which came in several sizes (1-4 passengers) and were powered by conventional gasoline engines with 2-4 cylinders. The study recommended segregating these small cars from larger vehicles in order to achieve the

largest traffic benefits. The phased implementation of a segregated roadway and parking system would begin by using portions of existing streets or entire narrow streets. Eventually the system could include new roadways, intersection flyovers or “underways,” and “over-ways,” which are elevated roadways over existing streets.

Minicar Transit System

The **Minicar** Transit System proposed by the University of Pennsylvania [1968] was aimed at improving convenience and reducing user costs while increasing roadway capacity and decreasing pollution and parking needs in the city. The idea involved the shared use of “Minicars” for fleet type operation in an urban/suburban setting as a modified form of mass transit. The proposed full-width but half-length **Minicars** had four wheels and were to be powered by a hybrid gasoline-electric engine. The **Minicars** could operate on automated, exclusive use, or dual-mode guideways, as well as on regular streets.

Neighborhood Cars

The Neighborhood Car study [Garrison and Clarke, 1977] was performed at the University of California at Berkeley. The goal was to maintain accessibility while extending mobility, improving neighborhood amenity, and dealing with congestion, environmental pollution, and energy depletion. The study assessed the marketability and implementation feasibility of using small “aid-to-walking” (ATW) vehicles for short neighborhood trips and collector/distributor segments of regional transit trips. The **golf**-cart like ATW vehicles were low speed, low cost, electric powered, four wheeled, and easy to operate. This Neighborhood Car concept constituted the neighborhood portion of a hierarchically differentiated urban personal transportation system, which could also include using urban cars for commuting trips (as in the lean vehicle study).

Mobility Enterprise

The Mobility Enterprise project at Purdue University [Doherty, Sparrow, and **Sinha, 1987**] was aimed at providing an alternative to public transportation and **carpooling** which conserved energy. The idea was to maintain personal freedom and mobility while

reducing expense and energy usage by using a “minimum attribute vehicle” (MAV) which better matched the trip requirements of an individual. The MAV was a standard mini or micro automobile with four wheels and a gasoline engine. The project involved a monthly fee that covered all operating costs, excluding gasoline, for full-time use of a MAV and a shared fleet of larger “special purpose vehicles.” The study involved both surveys of potential users and experiments which involved operation of a small fleet of vehicles.

Summary

All four of the studies above concentrated on small four-wheeled vehicles powered by electric and/or gasoline engines. However, the emphasis of these studies was not limited to the vehicle alone but considered the entire system. All but the Mobility Enterprise project considered facility design as an integral part of the study, as does the lean vehicle study. Although none of these minicar system studies has, as yet, had a major effect on today’s automotive transportation system, they are reviewed here because they were precursors to the lean vehicle study. In fact, the Lean Machine was originally designed during this same period and was inspired by the same mobility, energy, and environmental concerns which inspired the other studies. The lean vehicle idea can be thought of as the urban commuter portion of a hierarchically differentiated transportation system, as described in the Neighborhood Car study, which shares some facility design and implementation ideas with the Cars for Cities study.

APPENDIX B: THE EFFECT OF LEAN VEHICLES ON CAPACITY

Potential time savings benefits provided by lean vehicles would be the result of capacity increases in lanes with lean vehicles. The capacity increases would be due to a combination of the geometric effect of shorter vehicles and the possibility of side-by-side driving. Estimates of the nature and magnitude of the capacity increase are discussed below in order to provide a motivation for the modification of existing road facilities.

Geometric Effect

The relationship between flow, q , density, d , and speed, v , is

$$q = d v \quad (\text{B-1})$$

where flow is in vehicles per hour (vph), density is in vehicles per mile (vpm), and speed is in miles per hour (mph).

Density is the inverse of distance headway, h , which is the sum of the vehicle length, L , and the gap, G , between vehicles.

$$d = \frac{5280}{h} = \frac{5280}{L + G} \quad (\text{B-2})$$

Since h , L , and G are usually expressed in feet per vehicle, and d is in vehicles per miles, the conversion factor of 5280 feet per mile is necessary.

By combining (B-1) and (B-2) the capacity, μ_A , of a single lane of automobiles can be expressed as

$$\mu_A = \frac{5280 v_c}{L_A + G_c} \quad (\text{B-3})$$

where v_c is the velocity at capacity, L_A is the average automobile length, and G_c is the gap at capacity.

To estimate the “geometric effect” of shorter vehicles on capacity, which is a result only of the vehicle length, we assume the velocity, v_c , and gap, G_c , at capacity are the same as for automobiles. Thus, using (B-3) we can estimate the capacity, $\mu(L)$, of a stream of shorter vehicles.

$$\mu(L) = \frac{5280 v_c}{L + G_c} \quad (\text{B-4})$$

Prior research related to capacity increases from small cars will be reviewed **below**, followed by a discussion of capacity calculations particular to lean vehicles. Calculations for lean vehicles will be based on the dimensions of the G.M. Lean Machine.

Review of Prior Research

Wasielewski [1980] measured the **headways** between vehicles of various sizes on a near capacity freeway with free flow conditions, about 1800 vph at speeds near 50 mph. He concluded that by replacing the existing fleet of cars (average length 16 feet) with all small cars (12 feet), the capacity of 2000 vph at 30-40 mph would increase by about 8%. This is significantly more than the 5% increase which is due to the geometric effect of the small cars taking up less road space. Wasielewski credits the additional 3% increase to car size effects on **headways** due to both perception (i.e. apparent spacing) and driver behavior (i.e. risk acceptance).

Among the findings from the Mobility Enterprise project [Purdue University, 1985, p. 60] was that small vehicles were tailgated more often because they were perceived as larger vehicles which were farther away. They also found that small vehicles tailgated more often because of the over-representation of younger drivers, who tended to be more interested in concepts involving small vehicles. Tailgating of small vehicles could also be related to the ability of the following vehicle to see the traffic ahead of the lead vehicle by looking around, over, or through the lead vehicle.

Herman, Lam, and Rothery [1973] performed experiments with platoons of standard cars (18 feet) and small cars (14 feet) on a test track. Based on their measurements, they also predicted an increase in capacity of about 8% by changing from standard cars to small cars. Again, the geometric effect explains only about 5%, with the remainder due to driver-car-road interactions which are difficult to predict. The experiments also included measurements of saturation flow at an artificial signalized

intersection. They estimated that the capacity of 1800 vehicles per hour of green (vphg) for standard cars would increase by about 11% for small cars. The estimated geometric effect for this situation is about 6% if the cars cross the intersection at around 25 mph.

Steuart and Shin [1978] measured the **headways** between vehicles of various sizes departing from the queue at signalized intersections. Based on their measurements, they predicted an increase in capacity of 10% to 15% by changing from full-sized cars (18 feet) to small cars (12 feet). The lowest increase occurs when there are no turning movements, and the improvement increases with the fraction of turning movements. The estimated geometric effect for this situation is about 9% at 25 mph and 1800 vphg.

McClenahan and Simkowitz [1969] simulated the performance of an urban arterial with multiple signalized intersections for both large (20 feet) and very small (10 feet) vehicles. Their results and related calculations are particularly interesting because both the size and the ratio of the sizes are similar to those used for the lean vehicle situation, 18 feet for standard vehicles and 9 feet for Lean Machines. They calculated a 10% to 15% increase in flow at 40 mph with free flow conditions (near capacity) due to halving the vehicle length. Similarly, they estimated a 15% to 20% increase in saturation flow at a single signalized intersection. They found the improvement to be much greater for a series of intersections because the shorter vehicles would take up less space in the queue between the intersections and thus would create less blockage of the upstream intersection. Simulations with all vehicles being very small showed a 20% to 70% increase in flow for a series of closely spaced signalized intersections, depending on the average queue length. Other simulation runs with a mixture of very small and large vehicles showed that the percent improvement varied linearly with the fraction of very small vehicles, as would be expected. It is important to note that their calculations and simulations accounted for the geometric effect only and did not try to predict effects due to perception or driver behavior.

The **Minicar** Transit System study [University of Pennsylvania, 1968] also investigated the impact of vehicle length on intersection capacity. Using a computer

simulation based on a deterministic car following equation they calculated the increase in saturation flow as a function of the green time for a signal. They found that decreasing vehicle length from 18 feet to 9 feet (again, similar to the lean vehicle situation) increased the saturation flow by 6% (with 15 seconds of green) to 16% (with 75 seconds of green). The percent increase varied linearly with green time, giving an 8% to 11% increase in saturation flow for “reasonable” green times (25 to 45 seconds). These results are somewhat lower than the results of the other studies mentioned above.

Lean Vehicle Calculations

In order to determine the potential benefits of lean vehicles, it is necessary to estimate the capacity of a roadway under various conditions, including: free flow conditions on a multilane divided highway, free flow conditions on a two-lane undivided highway, and saturation flow from a signalized intersection. The discussion first focuses on the capacity of a single lane of traffic and then considers the ability of lean vehicles to drive side-by-side in a standard width lane.

The prior small car research summarized above, involving both controlled experiments and field measurements, identified capacity increases in excess of that due to the geometric effect of the small cars taking up less road space. This was the result of car size effects on headway due to both perception (i.e., apparent spacing) and driver behavior (i.e., risk acceptance). However, without a significant number of lean vehicles, estimates of capacity increases will have to be limited to the geometric effect only, because additional effects due to driver-car-road interactions are difficult to predict.

The Highway Capacity Manual [TRB, 1985, Chapter 2] gives the capacity of a single lane of roadway under free flow conditions on a multilane divided highway as about 2000 vph at speeds between 30 mph and 40 mph. By changing from standard vehicles (18 feet) to Lean Machines (9 feet) this capacity can be increased by 9% (at 40 mph) to 13% (at 30 mph). The value of 13% (at 30 mph) will be used for the capacity increase in further calculations regarding lean vehicles in this situation.

The capacity of a single lane of roadway under free flow conditions on a two-lane undivided highway varies from 1400 vph to 2000 vph depending on the directional split of traffic [TRB, 1985, Chapter 2]. The value for a **100/0** split (all flow in one direction) is 2000 vph at 30-40 mph, in which case the percent increase is the same as above. The capacity is 1400 vph at 50 mph for a **50/50** directional split (same flow in each direction), which can be increased by 5% with Lean Machines.

The Highway Capacity Manual [TRB, 1985, Chapter 93] suggests a value of 1800 vphg as the maximum saturation flow for a single lane at a signalized intersection. The flow increase provided by Lean Machines depends on the velocity and varies from 14% at 25 mph to 26% at 15 mph. A speed of 15 mph is representative of the first few vehicles in the queue when they cross the intersection, and a speed of 25 mph is representative of vehicles farther back in the queue. A value of 18% (at 20 mph) will be used for the capacity increase in further calculations regarding lean vehicles at a single signalized intersection. A value for multiple intersections cannot be obtained without a detailed simulation, but the results of **McClenahan and Simkowitz [1969]** can be considered applicable to the lean vehicle situation.

The calculated values of capacity increases provided by Lean Machines are in agreement with the previous studies mentioned above for both free flow conditions and saturation flow at individual intersections. Further calculations for the design of lean vehicle facilities will be based on these conservative estimates of roadway capacity increases, which are based only on the geometric effects of shorter vehicles.

For a traffic stream which consists of a mixture of lean vehicles and standard vehicles, the capacity increase will depend on the fraction of lean vehicles in the traffic stream. For each lean vehicle in the stream, the road space requirements are reduced by an amount equal to the difference in vehicle length compared to a standard vehicle. The capacity increase is inversely proportional to the fractional reduction in road space requirements.

Using (B-4) the capacity, $\mu(f)$, of a mixed traffic stream with a fraction, f , of lean vehicles can be expressed as

$$\mu(f) = \frac{5280 v_c}{L(f) + G_c} \quad (\text{B-5})$$

where $L(f)$ is the mixed average vehicle length which depends on f , L_A , and the lean vehicle length, L_L .

$$L(f) = f L_L + (1 - f) L_A \quad (\text{B-6})$$

Using (B-3), (B-5), and (B-6) the ratio of capacities is

$$\frac{\mu(f)}{\mu_A} = \frac{L_A + G_c}{L(f) + G_c} = \frac{L_A + \left(\frac{5280 v_c}{\mu_A}\right) - L_A}{f L_L + (1 - f) L_A + \left(\frac{5280 v_c}{\mu_A}\right) - L_A} \quad (\text{B-7})$$

which can be reduced to

$$\frac{\mu(f)}{\mu_A} = \frac{1}{1 - \left(\frac{\Delta_L \mu_A}{5280 v_c}\right) f} \quad (\text{B-8})$$

where Δ_L is the difference in vehicle length.

$$\Delta_L = L_A - L_L \quad (\text{B-9})$$

Side-by-Side Driving

The discussion above focuses on the capacity of a single lane of traffic without considering the ability of lean vehicles to drive side-by-side in a standard width lane, which might be possible if the vehicles are narrow and stable enough. Experiments by the Road Research Laboratory [Ministry of Transport, 1967, p. 13] using British Motors Minis (10 feet long by 4.5 feet wide) show that the minimum required lane width at city speeds is 2.5 to 3 feet wider than the vehicle. Woods and Ross [1983, p. 18] claim that vehicles need one foot of clearance on each side for low-speed operation (less than 30 mph) and two feet of clearance on each side for high-speed operation (greater than 35 mph). Based on these figures, a 6 foot wide lane should be adequate for a 3 foot wide Lean Machine in most urban driving situations. This should allow side-by-side driving of Lean Machines in

standard 12 foot wide lanes, provided that the vehicles have directional stability which is at least as good as existing cars. Whether or not additional lane stripes are necessary, and whether or not 6 feet is adequate, would have to be determined from experiments involving actual Lean Machines.

For a traffic stream which consists of a mixture of lean vehicles and standard vehicles, the ability of lean vehicles to drive side-by-side (if at all possible) will depend on the fraction of lean vehicles in the traffic stream. If vehicles are not able to rearrange their relative positions in the traffic stream, then the portion, P, of vehicles which can drive side-by-side is equal to the square of the fraction of lean vehicles, which is the probability of two lean vehicles in a row. However, if vehicles can rearrange their relative positions, then the portion of vehicles which can drive side-by-side is equal to the fraction of lean vehicles, since all of them could find and pair off with another lean vehicle.

$$P = \begin{cases} 0, & \text{single file} \\ f^2, & \text{paired} \\ f, & \text{rearranged} \end{cases} \quad (\text{B-10})$$

When both geometric effects and side-by-side driving are considered for a traffic stream which consists of a mixture of lean vehicles and standard vehicles, the capacity increase will again depend on the fraction of lean vehicles in the traffic stream. For each pair of lean vehicles the road space requirements are eliminated for one vehicle. For each pair of lean vehicles and for each unpaired lean vehicle, the road space requirements are reduced by an amount equal to the difference in vehicle length compared to a standard vehicle. The capacity increase is inversely proportional to the fractional reduction in road space requirements from both geometric effects and side-by-side driving.

Adjusting (B-9) to include the possibility of side-by-side driving gives a generalized equation for capacity,

$$\mu(f) = \frac{\mu_A}{\left(1 - \frac{P}{2}\right) - \left(\frac{\Delta_L \mu_A}{5280 v_c}\right) \left(f - \frac{P}{2}\right)} \quad (\text{B-11})$$

where P is the probability of driving side-by-side from (B-10), which depends on whether or not the lean vehicles can be rearranged within the traffic stream.

Figure B-1 shows the capacity increases for a mixed traffic stream due to both geometric effects and side-by-side driving. The curves are for a mixed stream of vehicles on a single lane of a multilane highway, with an automobile capacity, μ_A , of 2000 vph at a speed, v_c , of 30 mph, and a length difference, AL , of 9 feet. Results are shown for a single line of vehicles (no side-by-side allowed) and for side-by-side driving with and without rearrangement of vehicles in the traffic stream. The “paired” curve reflects the capacity if only lean vehicles which are initially adjacent can drive side-by-side, and the “rearranged” curve reflects when lean vehicles adjust their positions to be near other lean vehicles. The capacity for side-by-side driving with rearrangement is greater than the capacity without rearrangement except at the endpoints. As expected, the figure shows that with side-by-side driving the capacity of a stream of all Lean Machines is more than double the capacity of a stream of all standard vehicles. Similar curves can be drawn for capacity on two-lane highways and saturation flow at signalized intersections.

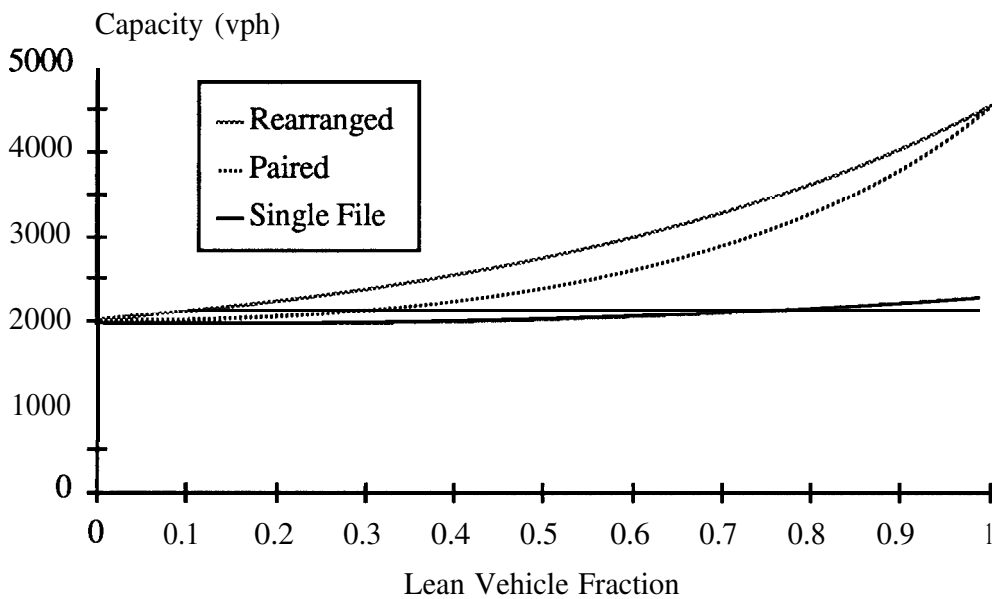

Figure B-1. Multilane highway capacity (per lane) vs. lean vehicle fraction.

Discussion

The capacity increases due to Lean Machines can be compared to those due to motorcycles, which are only slightly smaller and have similar performance characteristics. Adjustment factors for motorcycles come in the form of passenger car equivalents, the inverse of which gives the effective capacity increase. The Road Research Laboratory [1965, p. 201] gives passenger car equivalents for motorcycles of 0.33 at signalized intersections, 0.75 on urban streets, and 1.0 on rural highways. The comparable value for lean vehicles at signalized intersections would be about 0.42 for a stream of all Lean Machines with side-by-side driving. The value for motorcycles on urban streets is not directly comparable to the lean vehicle calculations discussed above, but perhaps a slightly higher value (about 0.85) could be used for Lean Machines. The comparable value for lean vehicles on rural highways would be about 0.95 for a stream of all Lean Machines without side-by-side driving on a two-lane undivided highway. The Highway Capacity Manual [TRB, 1985, Chapter 10, p. 4] gives a passenger car equivalent of 0.5 for motorcycles at unsignalized intersections. Again, this value is not directly comparable to the lean vehicle calculations discussed above, but a slightly higher value (perhaps 0.6) could be considered appropriate for Lean Machines at unsignalized intersections.

The previously mentioned experiments by the Road Research Laboratory [Ministry of Transport, 1967, p. 13] using British Motors Minis (10 feet long by 4.5 feet wide) determined the total road space requirements of these vehicles. The experiments considered both length and width and are therefore comparable to the lean vehicle calculations with side-by-side driving. The experiments showed that the passenger car equivalent of Minis is 0.9 in mixed urban traffic, providing a 10% increase in capacity for a stream of all Minis in standard width lanes. However, in segregated traffic with a stream of only Minis in narrow lanes, the passenger car equivalent is 0.67, providing a 50% increase in capacity. This capacity increase is less than for Lean Machines driving side-by-side because the Minis are wider than the proposed Lean Machines.

The Cars for Cities study [Ministry of Transport, 1967] calculated the capacity increases for small urban “Citycars” of several sizes (1-4 passengers). The smallest of these four-wheeled **Citycars** (one passenger) were 4 feet wide and 7 feet long, giving a “footprint” which has about the same area as that of a Lean Machines. These vehicles were to provide capacity increases of 10-15% in mixed traffic and about 100% in segregated traffic (Citycars in exclusive narrow lanes). When vehicle occupancy was considered, the study found that the person carrying capacity of single seat **Citycars** in mixed traffic is actually less than for standard cars, which have an average occupancy greater than one. However, the person carrying capacity of single seat **Citycars** in segregated traffic with narrow lanes is about 25% higher than standard cars in segregated traffic (no trucks). The results for Lean Machines would be similar if only single seat versions are considered, but if tandem Lean Machines are also considered then the person carrying capacity would depend on the average occupancy.

Actual values of lean vehicle capacities, which account for size, occupancy, the effects due to driver behavior and perception, and the willingness of drivers to drive **side-by-side**, will have to wait until there are enough lean vehicles to perform experiments and/or make measurements. This should not present much of a problem for the design of lean vehicle facilities because the decisions regarding initial facilities will depend on minimum required usage instead of capacity. These initial facilities will most likely be either facilities which are shared with conventional vehicles or inexpensive conversions of existing facilities. Capacities become important in deciding when to replace the initial facilities with more expensive facilities which are specially designed for lean vehicles. Thus, there should be ample time to get accurate values of lean vehicle capacities after the initial facilities are in operation but before they become congested and have to be replaced.

APPENDIX C: SAMPLE CALCULATIONS

Parking Modifications for Lean Vehicles

This section shows how equations (4.5) through (4.7), and the values in Tables 4.1 through 4.4 are used to generate the activity costs and market ranges in Tables 4.5 through 4.7. The dead space concept for surface parking lots is used as an example.

Upper and Lower Market Limits

Implementation of a dead space is expected to consist of removing some existing striping, adding striping to outline the new space, and installing a sign that designates the space. The implementation costs are summarized in the Table C- 1.

Table C-1 Implementation Costs for the Dead Space Concept

Action	Amount	Unit Cost ^a	cost
Remove striping	10 feet	\$2.00/foot	\$20
Add striping	25 feet	\$0.80/foot	\$20
Install sign	1 sign	\$100/sign	<u>\$100</u>
Total (C_d^I)			\$140

^a Unit costs are from Table 4.3.

We can find the lower market limit, L_d^0 , directly using (4.5) since no other technologies need to be implemented before dead spaces. Table 4.1 gives $N_d^R = 0$, and Table 4.2 gives $V = \$2,000$.

$$\begin{aligned}
 L_d^0 &= N_d^R + \text{Integer} \left[\frac{1}{V} \sum_y^d C_y \right] \\
 &= N_d^R + \text{Integer} \left[\frac{C_d^I}{V} \right] \\
 &= 0 + \text{Integer} \left[\frac{\$140}{\$2,000} \right] = 1
 \end{aligned}
 \tag{C-1}$$

The upper limit for the dead space concept is a physical limit which depends on the size and geometry of the original parking lot. For the 100 space parking lot used as an

example the maximum number of dead spaces is estimated to be $U_d^0 = 10$. The upper and lower limits for strategy one are the same as for strategy zero because the dead space concept is the first technology in strategy one, and all possible dead spaces would be used before the two-in-one concept is used since dead spaces do not lead to a reduction in the number of standard parking spaces.

First Application Limits

The first application of dead spaces depends only on the development of the dead space concept, which is estimated to take two months at a cost of $C_d^D = \$60,000$ based on Table 4.3. From (4.7) we can find the number of times the dead space concept must be applied to recover the development costs, N_d^0 (with $N_d^G = 1$ from Table 4.1).

$$\begin{aligned}
 N_d^0 &= \text{Integer} \left[\frac{\sum_z^d C_z^D}{N_d^G V - \sum_y^d C_y^I} \right] \\
 &= \text{Integer} \left[\frac{C_d^D}{N_d^G V - C_d^I} \right] \tag{C-2} \\
 &= \text{Integer} \left[\frac{\$60,000}{1 (\$2,000) - \$140} \right] = 33
 \end{aligned}$$

Thus we can determine the first application limit for strategy zero using (4.6).

$$\begin{aligned}
 F_d^0 &= N_d^0 N_d^R + \text{Integer} \left[\frac{1}{V} \sum_z^d C_z^D + \frac{N_d^0}{V} \sum_y^d C_y^I \right] \\
 &= N_d^0 N_d^R + \text{Integer} \left[\frac{C_d^D}{V} + \frac{N_d^0 C_d^I}{V} \right] \tag{C-3} \\
 &= 0 + \text{Integer} \left[\frac{\$60,000}{\$2,000} + \frac{33 (\$140)}{\$2,000} \right] = 33
 \end{aligned}$$

The first application limit for strategy one is the same as for strategy zero because the dead space concept is the first technology in strategy one.

Road Modifications for Lean Vehicles

This section shows how equations (3.5) through (3.13) and (5.14) through (5.27), and the values in Tables 5.1 through 5.5 are used to generate the activity costs and market ranges in Tables 5.6 through 5.8. The one-to-one shared lane concept for highway bottlenecks is used as an example.

Upper and Lower Market Limits

Implementation of a one-to-one shared lane is expected to consist of resurfacing the lane, restriping both sides, and installing signs every quarter mile to designate the shared lane. The implementation and market growth costs are summarized in Table C-2.

Table C-2 Implementation and Market Growth Costs for the One-to-one Concept

Action	Amount	Unit Cost ^a	Lifetime	Annual Cost
Implementation				
Resurface	12 feet by 1 mile	\$5,000/ft-mi	5 years	\$12,000
Stripe both sides	2 times 1 mile	\$2,500/mile	5 years	\$1,000
Install signs	1 mile	\$1,000/mile	5 years	\$200
Total (C^I_o)				\$13,200
Market Growth				
Maintenance	12 feet by 1 mile	\$250/ft-mi-yr	1 year	<u>\$3,000</u>
Total (C^M_o)				\$3,000

^a Unit costs are from Table 5.5.

No other technologies need to be implemented before the one-to-one shared lane, thus from (3.5),

$$\begin{aligned}
 C'_o &= \sum_y^o C^I_y + C^M_o \\
 &= C^I_o + C^M_o \quad (C-4) \\
 &= \$13,200/\text{yr} + \$3,000/\text{yr} = \$16,200/\text{yr}
 \end{aligned}$$

and we can find the lower market limit, L_o^0 , using (3.6) and (5.27).

$$\begin{aligned}
 L_o^0 &= B_o^{-1}(C'_o) \\
 &= B_o^{-1}(\$16,200/\text{yr}) \\
 &= 280 \frac{\text{lean vehicles}}{\text{peak period}}
 \end{aligned} \tag{C-5}$$

The upper limit is determined using (3.7) and (5.27).

$$\begin{aligned}
 U_o^0 &= B_o^{-1}(C'_o), U_o^0 > L_o^0 \\
 &= B_o^{-1}(\$16,200/\text{yr}) \\
 &= 6900 \frac{\text{lean vehicles}}{\text{peak period}}
 \end{aligned} \tag{C-6}$$

The lower limit for strategy one is the same as for strategy zero because the **one-to-one** concept is the first technology in strategy one. The upper limit for strategy one is equal to the lower limit of the **two-to-one** concept from strategy zero, because strategy one tries to implement the two-to-one concept as soon as possible.

First application limits

The first application of a one-to-one shared lane depends only on development of the one-to-one concept, which is estimated to take two months at a cost of $C^D_o = \$400,000$ based on Table 5.4. This value must be divided by the estimated shared lane lifetime of 5 years from Table 5.5 to get the annualized development cost using (3.11).

$$\begin{aligned}
 C''_o &= \sum_z^o C^D_z \\
 &= C^D_o \\
 &= \frac{\$400,000}{5 \text{ years}} = \$80,000/\text{yr}
 \end{aligned} \tag{C-7}$$

The maximum benefit of a one-to-one shared lane is $B_o^{\max} = \$390,000/\text{yr}$ from (5.27). From (3.12) we can find the number of times the one-to-one concept must be applied to recover the development costs, N_o^0 .

$$\begin{aligned}
N_o^0 &\geq \frac{C''_o}{B_o^{\max} - C'_o} \\
&\geq \frac{\$80,000/\text{yr}}{\$390,000/\text{yr} - \$16,200/\text{yr}} && \text{(C-8)} \\
N_o^0 &= 1
\end{aligned}$$

Thus we can determine the first application limit for strategy zero using (3.13).

$$\begin{aligned}
F_o^0 &= B_o^{-1}(C''_o + N_o^0 C'_o) \\
&= B_o^{-1}(\$80,000/\text{yr} + \$16,200/\text{yr}) && \text{(C-9)} \\
&= 1690 \frac{\text{lean vehicles}}{\text{pea-k period}}
\end{aligned}$$

The first application limit for strategy one is the same as for strategy zero because the one-to-one concept is the first technology in strategy one.

BIBLIOGRAPHY

- Adamiecki, Karol [1931]. "Harmonygraph." *Przegląd Organizacji (Polish Journal on Organizational Review)*.
- Alger, John R. M., and Carl V. Hays [1964]. *Creative Synthesis in Design*. Englewood Cliffs, N.J.: Prentice-Hall.
- Ang, A. H.-S., J. Abdelnour, and A. A. Chaker [1975]. "Analysis of Activity Networks Under Uncertainty." *Journal of the Engineering Mechanics Division, Proceedings of the American Society of Civil Engineers*. Vol. 101 (No. EM4), pp. 373-87.
- Bagon, Arnold A. [1980]. "Painless Birth of an Urban Bridge." *Civil Engineering*. Vol. 50 (May), pp. 72-73.
- Bennett, F. Lawrence [1977]. *Critical Path Precedence Networks*. New York: Van Nostrand Reinhold.
- Broadbent, Geoffrey [1981]. "Design Methods - 13 Years After - A Review." In *Design: Science: Method*. Edited by Robin Jacques and James A. Powell. Surrey, Eng.: Westbury House, pp. 3-5.
- Caunter, C. F. [1957]. *The History and Development of Light Cars*. London: Her Majesty's Stationery Office.
- Clymer, Floyd [1957]. *Treasury of Foreign Cars: Old and New*. New York: McGraw-Hill.
- Doherty, M. J., F. T. Sparrow, and K. C. Sinha [1987]. "Public Use of Autos: Mobility Enterprise Project." *Journal of Transportation Engineering*. Vol. 113 (No. 1), pp. 84-94.
- Edwards and Kelcey [1978]. *Bikeway Planning and Policy Guidelines for New York City: Manhattan Commuter Bicycle System Study*. New York: N.Y.C. Department of Transportation.
- Egan, Peter [1983]. "Lean Machine: Logic and Substance from the Dreamer's Workshop." *Road & Track*. Vol. 34 (January), pp. 80B-80D.
- Feamsides, John J. [1987]. "How Programs Come Together." In *Technology Options for Highway Transportation Operations*. Pub. No. UCB-ITS-P-87-1. Berkeley: Institute of Transportation Studies, University of California, pp. 169-179.
- Fondahl, J. W. [1961]. *A Noncomputer Approach to the Critical Path Method for the Construction Industry*. Stanford, Calif.: Department of Civil Engineering, Stanford University.
- Garrison, William L. [1989]. "Using Technology to Improve Transportation Services." In *Transportation for the Future*. Heidelberg: Springer-Verlag, pp. 87-122.
- Garrison, William L., and J. Fred Clarke, Jr. [1977]. *Prospects for Neighborhood Cars*. Research Report UCB-ITS-RR-77-15. Berkeley: University of California, Institute of Transportation Studies.

- Garrison, William L., and Mark E. Pitstick [1990a]. *Lean Machines: Preliminary Investigations*. PATH Research Report UCB-ITS-PRR-90-4. Berkeley: University of California, Institute of Transportation Studies, Program on Advanced Technology for the Highway.
- Garrison, William L., and Mark E. Pitstick [1990b]. "Lean Vehicles: Strategies for Introduction Emphasizing Adjustments to Parking and Road Facilities." SAE Technical Paper No. 901485. In *Automated Highway/Intelligent Vehicle Systems: Technology and Socioeconomic Aspects*. SP-833. Warrendale, Penn.: Society of Automotive Engineers, pp. 17-33.
- Grubler, Arnuf [1989]. *The Rise and Fall of Infrastructures: Dynamics of Evolution and Technological Changes in Infrastructures*. Heidelberg: Physica-Verlag.
- Herman, Robert, Tenny Lam, and Richard Rothery [1973]. "An Experiment on Car Size Effects in Traffic." *Traffic Engineering & Control*. Vol. 15 (No. 2), pp. 90-92.
- JHK & Associates [1985]. *Seven Corners Pedestrian Bridge Feasibility Study: Final Report*. Fairfax County, Virg.: Department of Public Works.
- Jackson, Judith [1979]. *Man and the Automobile*. New York: McGraw-Hill.
- Jones, J. Christopher [1984]. *Essays in Design*. Chichester, Eng.: John Wiley & Sons.
- Kelly, James E., and Morgan R. Walker [1959]. "Critical Path Planning and Scheduling." *Proceedings of the Eastern Joint Computer Conference*. December 1-3, N.p., pp. 160-173.
- Kostyniuk, Lidia P., Thomas L. Maleck, William C. Taylor, and Abdul-Rahman I. Hamad [1988]. *An Evaluation of the Detroit Freeway Operations (SCANDI) Project*. Report No. FHWA-MI-RD-88-02. East Lansing, Mich.: Michigan State University, College of Engineering.
- Lave, Charles A. [1980]. "Conservation of Energy in the Urban Passenger Sector: A General Principle and Some Proposals." *Transportation Research -A*. Vol. 14A (No. 5-6), pp. 321-326.
- Lockyer, K. G. [1964]. *An Introduction to Critical Path Analysis*. New York: Pitman.
- Malcolm, D. G., J. H. Roseboom, C. E. Clark, and W. Fazar [1959]. "Applications of a Technique for Research and Development Program Evaluation." *Operations Research*. Vol. 7 (No. 5), pp. 646-669.
- Martin Marietta, Air Traffic Control Division [1984]. *System Engineering and Integration Contract for Implementation of the National Airspace System Plan*. Report No. ATC-84-0026. Washington, D.C.: Martin Marietta.
- Matteucci, Marco [1970]. *History of the Motorcar*. London: Times-Mirror.
- McClenahan, John W., and Howard J. Simkowitz [1969]. "The Effect of Short Cars on Flow and Speed in Downtown Traffic: A Simulation Model and Some Results." *Transportation Science*. Vol. 3 (No. 2), pp. 126-39.
- Ministry of Transport [1967]. *Cars for Cities*. London: Her Majesty's Stationery Office.

- Moder, Joseph J., Cecil R. Phillips, and Edward W. Davis [1983]. ***Project Management with CPM, PERT, and Precedence Diagramming***. Second Edition. New York: Van Nostrand Reinhold.
- Newell, Gordon F. [1982]. ***Applications of Queueing Theory***. Second Edition. London and New York: Chapman and Hall.
- Oak Ridge National Laboratory [ORNL, 1986]. ***Motor Vehicle MPG and Market Shares Report***. Oak Ridge, Tenn.: ORNL.
- O'Brien, James J. [1984]. ***CPM in Construction Management***. Third Edition. New York: McGraw-Hill.
- Pleasants, William W. [1980]. "The Fly-Over: It Unclogs Urban Traffic in a Hurry." ***Civil Engineering***. Vol. 50 (May), pp. 71-75.
- Posthumus, Cyril [1982]. "Oddities, Absurdities & Fanciful Machines." ***Road & Track***. Vol. 34 (May), pp. 100-104.
- Purdue University, Automotive Transportation Center [1985]. ***A Special Study of the Safety Implications of the Utilization of Small Urban Cars in the U.S.A.*** West Lafayette, Ind.: Purdue University.
- Raus, Juri [1981]. ***A Method for Estimating Fuel Consumption and Vehicle Emissions on Urban Arterials and Networks***. Report No. FHWA-TS-81-210. Washington, D.C.: U.S. Department of Transportation, Federal Highway Administration.
- Rittel, Horst W. J., and Melvin M. Webber [1973]. "Dilemmas in a General Theory of Planning." ***Policy Sciences***. Vol. 4 (No. 2), pp. 155-169.
- Road Research Laboratory [1965]. ***Research on Road Traffic***. London: Her Majesty's Stationery Office.
- Rzevski, George [1981]. "On the Design of a Design Methodology." In ***Design: Science: Method***. Edited by Robin Jacques and James A. Powell. Surrey, Eng.: Westbury House, pp. 6-17.
- Salzer, J. M. [1961]. "Evolutionary Design of Complex Systems." In ***Systems Research and Design***. Edited by D. P. Eckman. New York: John Wiley & Sons, pp. 197-215.
- Simon, Herbert A. [1981]. ***The Sciences of the Artificial***. Second Edition. Cambridge, Mass.: The MIT Press.
- Steadman, Philip [1979]. ***The Evolution of Designs: Biological Analogy in Architecture and the Applied Arts***. Cambridge, Eng.: Cambridge University Press.
- Steuart, Gerald N., and Bu-Yong Shin [1978]. "The Effect of Small Cars on the Capacity of Signalized Urban Intersections." ***Transportation Science***. Vol. 12 (No. 3), pp. 250-263.
- Transportation Research Board [TRB, 1985]. ***Special Report 209: Highway Capacity Manual***. Washington, D.C.: National Research Council.

- Transportation Research Board [TRB, 1987]. *Special Report 214: Designing Safer Roads: Practices for Resurfacing, Restoration, and Rehabilitation*. Washington, D.C.: National Research Council.
- U.S. Department of Transportation, Federal Aviation Administration [U.S. DOT/FAA, 1984]. *National Airspace System Plan: Engineering and Development*. Washington, D.C.: U.S. DOT, FAA.
- U.S. Department of Transportation, Federal Aviation Administration [U.S. DOT/FAA, 1989]. *National Airspace System Plan: Facilities, Equipment, Associated Development and Other Capital Needs*. Washington, D.C.: U.S. DOT, FAA.
- U.S. General Accounting Office [U.S. GAO, 1983]. *FAA's Plan to Improve the Air Traffic Control System: A Step in the Right Direction but Improvements and Better Coordination are Needed*. Report No. GAO/AFMD-83-34. Washington, D.C.: U.S. GAO.
- U.S. General Accounting Office [U.S. GAO, 1987]. *Effects of Delay in FAA's NAS Plan*. Testimony No. GAO/T-RCED-87-27. Washington, D.C.: U.S. GAO.
- University of Pennsylvania, Minicar Project [1968]. *Minicar Transit System: Final Report on Phase - I*. Philadelphia: University of Pennsylvania.
- Vance, James E., Jr. [1986]. *Capturing the Horizon: The Historical Geography of Transportation Since the Transportation Revolution of the Sixteenth Century*. New York: Harper & Row.
- Von Hayek, Friedrich A. [1945]. "The Use of Knowledge in Society." *American Economic Review*. Vol. 35 (No. 4), pp. 519-530.
- Wasielowski, Paul F. [1980]. *The Effect of Car Size on Headways in Freely Flowing Freeway Traffic*. Report No. GMR-3366. Warren, Mich.: General Motors Research Laboratories.
- Weant, Robert A., and Herbert S. Levinson [1990]. *Parking*. Westport, Conn.: Eno Foundation for Transportation.
- Whitehouse, Gary E. [1973]. *Systems Analysis and Design Using Network Techniques*. Englewood Cliffs, N.J.: Prentice-Hall.
- Whitlock, Edward M. [1982]. *Parking for Institutional and Special Events*. Westport, Conn.: Eno Foundation for Transportation.
- Wingate, P. J. F. [1966]. *Use of Critical Path Method on Road Construction Projects*. RRL Report No. 1. Harmondsworth, Eng.: Ministry of Transport, Road Research Laboratory.
- Woods, Donald L., and Hayes E. Ross [1983]. "Potential Impact of the Microvehicle on Roadway Facilities." In *Transportation Research Circular* 264. Washington, D.C.: National Research Council, Transportation Research Board, pp. 18-23.