

REUSABLE ROCKET ENGINE TURBOPUMP
CONDITION MONITORING

M. E. Hampson and S. Barkhoudarian

Rockwell International/Rocketdyne Division
Canoga Park, California

Abstract

Significant improvements in engine readiness with attendant reductions in maintenance costs and turn-around times can be achieved with an engine condition monitoring system (CMS). The CMS provides real time health status of critical engine components, without disassembly, through component monitoring with advanced sensor technologies. Over 100,000 engine failure reports from the past 35 years were reviewed and categorized into 20 different modes of failure. Of the failure reports reviewed, rotor bearings and turbine blades were determined to be the most critical in limiting turbopump life. Over 200 in-flight and between-flight measurement technologies were then reviewed and matched to direct, noninferential detection of failure mode signatures. Three of these technologies were selected to monitor the rotor bearings and turbine blades: the isotope wear detector and fiberoptic deflectometer (bearings), and the fiberoptic pyrometer (blades). Signal processing algorithms were evaluated and ranked for their utility in providing useful component health data to unskilled maintenance personnel. Design modifications to current configuration Space Shuttle Main Engine (SSME) high pressure turbopumps and the MK48-F turbopump were developed to incorporate the sensors. Laboratory test fixtures have been designed for monitoring the rotor bearings and turbine blades in simulated operating environments.

Work performed under NASA-LeRC Contract No. NAS3-23349, under the direction of Robert Masters, Technical Manager.

Introduction

Until the advent of the multiflight rocket engine of the Space Shuttle, the need for extensive engine condition monitoring was not seen as necessary or cost effective. However, the current life and performance requirements placed on the SSME and other high performance, reusable rocket engines now make a condition monitoring system (CMS) very attractive in these respects. Significant reductions in engine system, and therefore mission, costs, turnaround, and maintenance times can be achieved by implementing a CMS into the engine. These reductions are possible by knowing critical engine component health and expected remaining life from the information provided by the CMS. Other benefits include improved engine control and improved knowledge of the engine operating condition.

In September 1980, a program was initiated by the NASA Lewis Research Center with the objective of defining the requirements of a CMS and to perform tests of the system. The first phase of the program was a study in which engine failures from the past 35 years were reviewed and categorized into general failure categories. These categories were then matched to sensor technologies capable of monitoring them directly. The current phase further defined the CMS and determined design modifications necessary for incorporation into several high performance turbopumps. At the present, efforts are underway to design and fabricate turbopump simulation test fixtures in which laboratory testing of the CMS can be performed.

Defining Turbopump Life Limiters

Documentation of rocket engine failures and/or discrepancies has been quite thorough over the past 35 years. Unsatisfactory Condition Reports (UCR) exist for every engine system made. This translates into over 100,000 individual pieces of information relating to engine failures or discrepancies. To successfully manage this volume of data for use on this program, a screening process was established that eventually reduced this number to 1771.

The first major screen was to consider only those engine systems still in production, and those designed for manned application in the Apollo program. The engine systems then remaining for consideration were the following:

1. SSME: Space Shuttle Orbiter
2. J-2: Saturn IB and V
3. H-1: Saturn IB
4. F-1: Saturn V
5. RS-27: Delta
6. Thor: Thor
7. Atlas: Atlas and Atlas-Centaur

The next screen eliminated from consideration those UCRs obtained from experimental engine systems. Following this, only those UCRs applying to engines during acceptance tests were allowed (an acceptance test contains hot-fire tests, mainstage simulations, and post-hot-fire tests). The next screen eliminated UCRs due to procedural problems, human error, low-frequency failures, obsolete hardware, and facility and vehicle discrepancies. Finally, since the bulk of the data was obtained from expendable rocket engine experience, only those remaining UCRs which had significance in a reusable rocket engine system were considered. Figure 1 shows the distribution of UCRs among the seven engine systems listed above.

Once the data base had been established, the next step was to search for common failure information. After a thorough review and grouping procedure, there emerged 16 general failure modes present in the data base:

1. Bolt Torque Relaxation
2. Coolant Passage Splits
3. Joint Leakage
4. Hot-Gas Manifold Transfer Tube Cracks
5. High Torque
6. Cracked Turbine Blades
7. Failure of Bellows
8. Loose Electrical Connectors
9. Bearing Damage

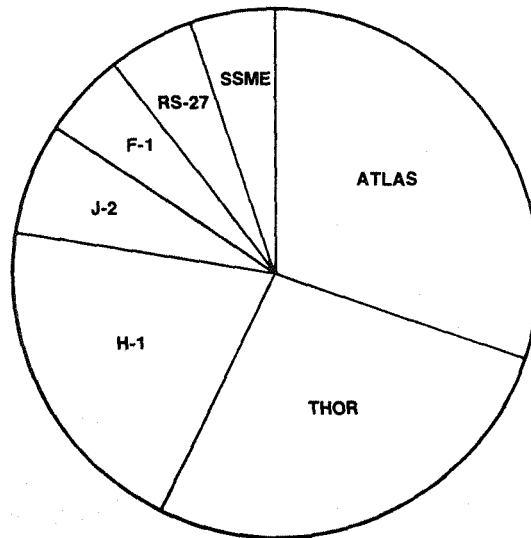

Fig. 1. Distribution of UCRs by Engine Systems After Screening

10. Tube Fracture
11. Turbopump Face Seal Leakage
12. Lube Pressure Anomalies
13. Valve Fails to Perform
14. Valve Internal Leakage
15. Regulator Discrepancies
16. Contaminated Hydraulic Control Assembly

As can be seen from the list above, several items apply directly to the reusable turbopump: high torque, cracked turbine blades, bearing damage, and face seal leakage. The second phase effort of the NASA Lewis program identified four other failure modes of the turbopump which were also considered significant: turbine blade erosion, turbine nozzle cracking, turbine sheet metal and housing cracking, and cavitation damage. The second phase effort has concentrated on developing the condition monitoring capability for the turbopump's turbine blades and bearings. This effort will be discussed in greater detail later in the paper.

Correlating Sensors to Life Limiters

Attendant to each of the failure modes listed above is a characteristic failure mode signature. Each failure mode progresses along a failure propagation path, or one of several propagation paths, until engine shutdown or engine or engine component failure occurs. Figure 2 presents an example of a turbine blade failure propagation block diagram. At each major event along the path in Fig. 2 (e.g., blade cracking) there appears an attendant, detectable signature (e.g., vibration) that indicates the presence of that event. The next major step in the CMS study, then, was to develop failure propagation block diagrams for each of the failure modes, and correlate to the failure signatures advanced sensors capable of detecting their presence.

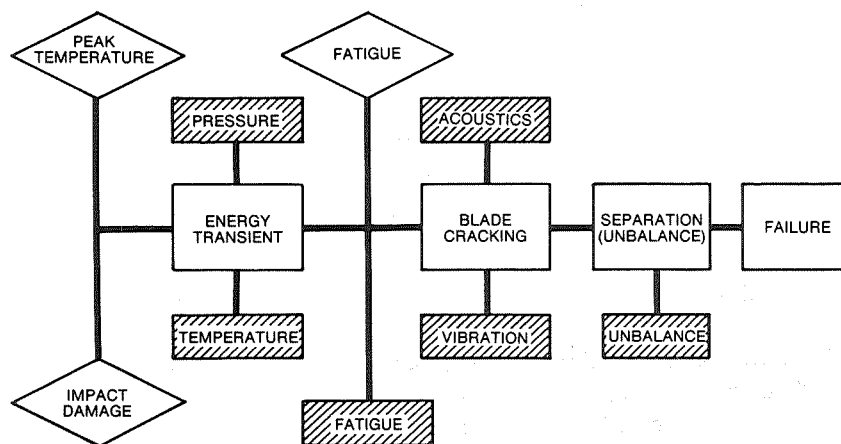

Fig. 2. Turbine Blade Failure

As a result of developing the failure propagation block diagrams, 23 distinct failure mode signatures, or measurands, were identified for in-flight and between-flight condition monitoring. For example, ball bearing damage exhibits such failure mode signatures as vibration, wear particles, excessive temperature, and rpm tailoff. Table 1 correlates each of the failure modes to the 23 signatures. Also indicated in Table 1

Table 1. Failure Modes Correlated to Signature

FAILURE MODE	FAILURE MODE SIGNATURE																												
	VIBRATION	ACOUSTICS	LEAKS	FRETTING	EXTENSION	METAL BRITTLENESS	PRESSURE TRANSIENT	FLOW REDUCTION	M/A SHIFT	COMBUSTION	FIRE	TEMPERATURE RISE	FATIGUE	TORQUE TRANSIENT	WEAR RIPPLES	RPM PARTICLES	CONTAMINANTS	BALANCE	TORQUE	INTERMITTENT CONTINUITY	SEPARATION	DEFORMATION	MOISTURE	EXCESSIVE TEMPERATURE	FOREIGN OBJECT DAMAGE	PHYSICAL INTERFERENCE	STICK COMPONENTS	CALLING	
BOLT TORQUE RELAXATION	I	I	I	I																									
COOLANT PASSAGE LEAKAGE/RESTRICTION																													
JOINT LEAKAGE			IB			IB	IB	I																					
TRANSFER TUBE CRACK																													
HIGH TURBOPUMP TORQUE																													
CRACKED TURBINE BLADE																													
TURBINE BLADE EROSION																													
TURBINE NOZZLE CRACKING																													
TURBINE SHEET METAL AND HOUSING CRACKING																													
CRACKED CONVOLUTION, BELLOWS, SHIELDS																													
LOOSE ELECTRICAL CONNECTORS																													
BALL BEARING DAMAGE																													
SMALL TUBE FRACTURE																													
TURBOPUMP SEAL LEAKAGE																													
CAVITATION DAMAGE																													
LUBE PRESSURE ANOMALIES																													
VALVE FAILURE																													
VALVE INTERNAL LEAKAGE																													
REGULATOR DISCREPANCIES																													
CONTAMINATED HYDRAULICS																													

I = IN FLIGHT; B = BETWEEN FLIGHT

is whether the signature is used for in-flight condition monitoring (I), between-flight condition monitoring (B), or both (IB).

Four categories of sensing technologies exist that apply to rocket engine monitoring: conventional, such as temperature and pressure; rocket engine, i.e., sensors such as temperature and accelerometers with rocket engine operating experience; state of the art, such as the fiberoptic pyrometer and isotope wear detectors; and novel technologies, such as the exo-electron fatigue detector. The first step taken in identifying candidate sensors applicable to the CMS was to perform a literature search. A search of nearly six million citations on the subject yielded 289 abstracts and 78 articles, from which over 200 candidate sensors were selected. A screening procedure analogous to that used in reducing the UCR data base was established for final sensor selection. Based on the screening criteria, the list of 200 candidate sensors was reduced to 19: 11 novel, 6 state of the art, and 2 in the rocket engine category.

The 19 candidate sensors were then subjected to a grading and ranking procedure. Each of the sensors has liabilities and virtues in both technical and economic aspects. Many of the novel technologies require development time before being acceptable for use. The 19 candidates were evaluated in each of these areas and compared to the 20 failure modes listed in Table 1. The final sensor selection was made from this comparison. Detection of each failure mode was satisfied first, then only those sensors with the highest score were selected. Final sensor selection versus the failure modes is shown in Table 2. Note that several of the failure modes were not detectable with any viable condition monitoring technique. Also indicated in this table is whether the monitoring technology is an in-flight monitoring technology (I), between-flight monitoring technology (B), or both (IB).

Table 2. Sensors Correlated to Failure Modes

SENSORS	FAILURE MODES																				
	BOLT TORQUE RELAXATION	COOLANT PASSAGE LEAKS	JOINT LEAKAGE	TRANSFER TUBE CRACKS	HIGH TURBOPUMP TORQUE	CRACKED TURBINE TORQUE	TURBINE BLADE TORQUE	TURBINE BLADE EROSION	TURBINE NOZZLE CRACKING	CRACKED SHEET METAL AND HOUSING CRACKING	LOOSE CONVOLUTION, BELLOWS, SHIELDS	BALL BEARING DAMAGE	SMALL TUBE FRACTURE	TURBOPUMP SEAL LEAKAGE	CAVITATION DAMAGE	LUBE PRESSURE ANOMALIES	VALVE FAILURE	VALVE INTERNAL LEAKAGE	REGULATOR DISCREPANCIES	CONTAMINATED HYDRAULICS	
FIBEROPTIC DEFLECTOMETER																					
PYROMETER																					
TUNABLE DIODE-LASER SPECTROMETER	IB																				
ISOTOPE WEAR DETECTOR				IB	B							IB	IB			IB	IB				
ULTRASONIC THERMOMETER	I																				
OPTICAL TACHOMETER																					
ULTRASONIC FLOWMETER	I																				
DIGITAL QUARTZ PRESSURE SENSOR	I																				
HALOGRAPHIC LEAK DETECTOR	B	B																			
THERMAL CONDUCTIVITY LEAK DETECTOR		B																			
EXO-ELECTRON FATIGUE DETECTOR					B																
CONNECTOR CONTINUITY CHECKING										B											
PARTICLE ANALYSIS				B							B		B			B	B	B	B		B

I = IN-FLIGHT MEASUREMENT; B = BETWEEN-FLIGHT MEASUREMENT

Selecting Useful Turbopump Condition-Monitoring Algorithms

Completion of the sensor selection process for the failure modes signaled the end of the first phase of the NASA Lewis program. It was decided at this point to develop a CMS for the most critical subsystem of pump-fed, liquid rocket engines: the reusable turbopump. The remainder of this paper, therefore, deals exclusively with the development of a CMS for the turbopump.

Failure mode detection does not stop upon receiving a signal from the sensor. Many of the signals received contain large amounts of information that reveal component health only upon processing and correlating to other sensor outputs. The signal processing selected for use must also be easily

used by nonskilled maintenance personnel, i.e., they must provide personnel with reliable go/no-go information. A block diagram illustrating the path followed by the failure mode signature is shown in Fig. 3. The most critical part of the CMS is in the signal processing and decision making processes.

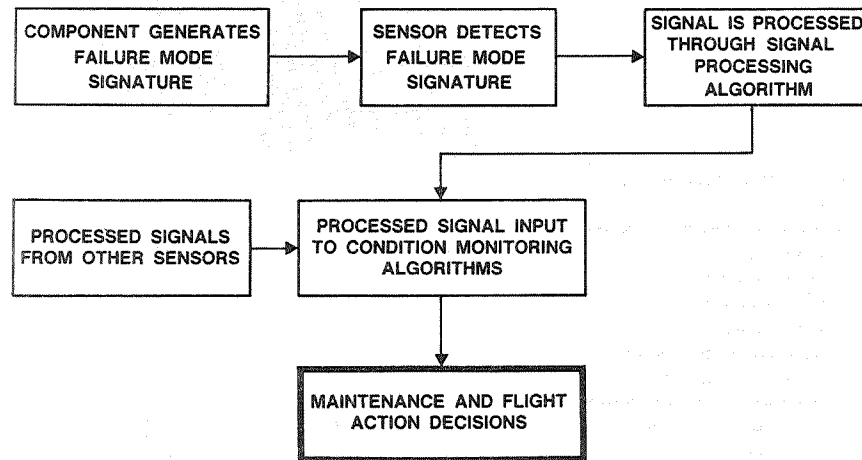

Fig. 3. Progression of Failure Mode Signatures

Each failure mode signature was reviewed and analyzed to determine what sensor output would occur during nominal and off-nominal component operation. Periods of steady-state operation were selected as the baseline engine operating condition for initial selection of the signal processing algorithms. Transient operating periods were incorporated later since they contain significant amounts of information relating to the remaining useful life of the component.

Fourteen signal processing algorithms were evaluated for their usefulness in providing component condition information. Listed in Table 3 are the algorithms along with the four criteria used in their evaluation: sensitivity, intelligence, isolation, and simplicity. Sensitivity is the ability of the algorithm to detect small or subtle changes in sensor output.

Table 3. Evaluation of Available Signal Processing Algorithms

ALGORITHMS	SENSITIVITY	INTELLIGENCE	ISOLATION	SIMPLICITY
AMPLITUDE HISTOGRAM	L	M	M	L
RMS HISTOGRAM	L	M	M	L
FILTERED HISTOGRAM	H	M	H	L
CROSS CORRELATION	H	M	M	L
TRANSFER FUNCTION	H	H	M	L
PRODUCTION HISTOGRAM	L	M	L	L
RATIO HISTOGRAM	M	M	M	L
DIFFERENTIATED HISTOGRAM	H	M	H	L
PHASE DIAGRAM HISTOGRAM	L	M	L	M
TIME PROFILE	L	L	L	L
POWER SPECTRUM DENSITY	L	H	M	M
INTEGRAL OVER THRESHOLD	L	L	L	H
RPM PROFILES	L	L	L	L
CAMPBELL DIAGRAM	L	L	L	L

GRADING LEGEND:
L = LOW
M = MID
H = HIGH

Intelligence indicates the general utility of the information provided. Isolation refers to the algorithm's ability to discriminate between common signals generated by different sources. Simplicity is the ease at which the desired information can be retrieved. During the forthcoming system tests of the CMS, all 14 signal processing algorithms will be evaluated to determine their ability in producing the desired information.

Once the signal is processed, it is correlated with processed signals from other sensors, where appropriate, through a decision-making comparator. Routing the processed signals through a comparator increases confidence that the failure mode of interest is occurring. This is due to the fact that all failure modes generate more than one failure signature and can therefore be monitored by multiple sensors. All sensors capable of detecting a particular failure mode would have to register a change from nominal output before occurrence of the mode was confirmed.

Testing the CMS in Turbopump Simulators

Evaluation of the CMS developed up to this point under controlled laboratory conditions is the next logical step toward full development of a CMS. Testing of the CMS in an operating turbopump would not only be expensive and hardware intensive, but may not provide a thorough understanding of the details involved in the signal processing and decision-making algorithms. It was at this point in the NASA Lewis program that the decision was made to perform condition monitoring tests on the two most critical turbopump failure modes identified: the rotor bearings and turbine blades.

A Turbopump Simulation Test Plan (TSTP) was developed that described the testing proposed to fully evaluate monitoring the condition of turbopump bearings and turbine blades. In developing the TSTP, environments and operating conditions to which these components are exposed during actual turbopump operation were identified. The baseline turbopumps to which the simulators were designed are the SSME High Pressure Fuel and High Pressure Oxidizer Turbopumps (HPFTP and HPOTP). Also defined in the TSTP are tests that evaluate the ability of the sensor to survive the environment in which it is installed.

Tests on the turbopump bearings simulate those conditions found in the SSME high pressure oxidizer turbopump turbine end bearings. The baseline conditions identified are the following:

1. Rotating radial loads up to 2000 lbf
2. Axial loads up to 6000 lbf (transient)
3. Speeds to 30,000 rpm
4. Liquid oxygen flowrates to 30 gpm

A bearing tester was designed and fabricated that emulated all of the above conditions except the liquid oxygen environment; liquid nitrogen is used as the coolant instead. As shown in Fig. 4, the tester incorporates two old configuration SSME high pressure oxidizer turbopump bearings, P/N RS007787, mounted

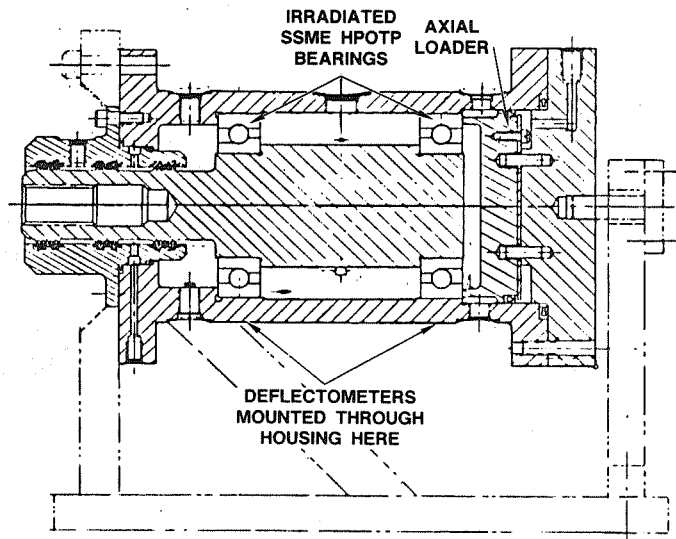

Fig. 4. Cryogenic Bearing Tester

to a shaft and installed in a housing that somewhat resembles a porcupine. Each bearing can be monitored with six fiberoptic deflectometers monitoring its outer surface. Either bearing can be monitored with the isotope wear detector by surface layer irradiation of part of the bearing, and then monitoring the wear *in situ* without disassembly. The drive-end bearing (shown to the left in the figure) is also monitored upstream and downstream by pressure and temperature probes. Accelerometers are mounted to the housing in three perpendicular planes to act as both real-time test monitors and known correlation to data received from the deflectometers. Axial loads are provided by a pneumatic piston to the right of the slave bearing and acting on the outer race of the same. Radial loads are provided by mounting weights in the form of set screws to the shaft. Liquid nitrogen can flow in any one of three directions: from drive-end to slave-end, vice-versa, or from midtester out to both bearings (parallel flow path).

Monitoring of bearing condition by the fiberoptic deflectometer is accomplished by utilizing reflected light from the bearing outer race surface.

Figure 5 illustrates this principle. Light is transmitted by a portion of the fibers in the probe to the race surface. Some of this light is reflected off the surface and is received by the remainder of the fibers. This light is then processed through a photodetector to provide an electrical signal proportional to bearing race surface deflection. Frequency and amplitude content analysis of the signal provides information on bearing condition.

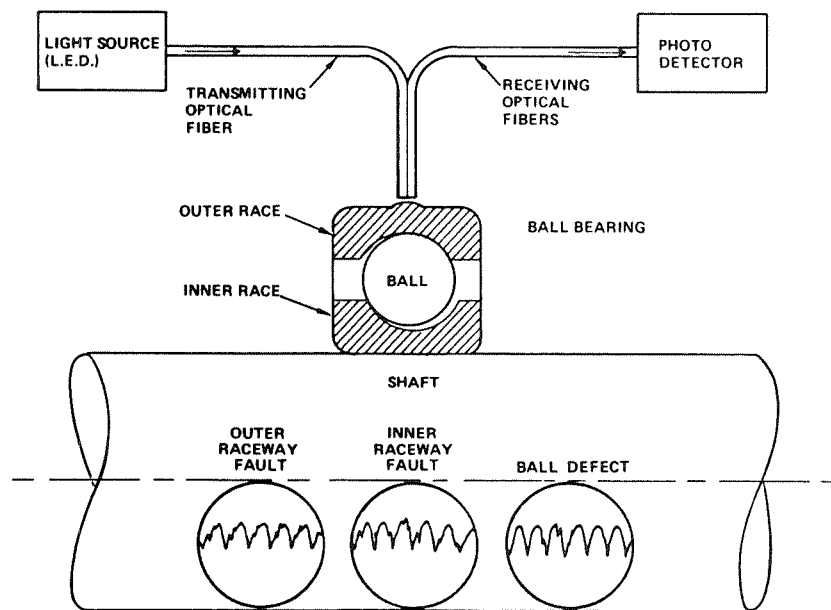

Fig. 5. Fiberoptic Deflectometer

The isotope wear detector monitors bearing health by directly measuring the amount of wear in a component that has been irradiated. For example, monitoring of bearing health by measuring outer race ball track wear depth is accomplished by irradiating the ball track to a certain depth and width (e.g., 0.032 x 0.025 inch), then monitoring the change in radioactive count rate of the isotope present in the race with a photomultiplier crystal. After accounting for half-life decay of the isotope, a direct determination of wear depth can be made from a calibration curve that

has correlated change in countrate to wear depth for the particular material in use. Measurements with the isotope wear detector are made *in situ*, since the radiation will penetrate the turbopump housing material. Activity levels of the isotope are quite low, usually below 10 microcuries, and therefore pose no health hazards to maintenance personnel. Note that the isotope wear detector is capable of monitoring any component that exhibits wear as a failure mode signature.

Tests on the turbine blades will simulate those conditions found in the SSME high pressure fuel turbopump first-stage turbine. The steady-state operating conditions found in the high pressure fuel turbopump are the following:

1. Speed to 38,000 rpm
2. Blade temperature to 1900 R
3. Active turbine disk cooling

An existing test fixture built on a previous NASA program proved to be sufficient in meeting the test goals. Shown in Fig. 6 is the rotating diagnostic device, more commonly known as the whirligig. The whirligig was originally built for evaluation of turbine blade dampers for both the SSME high pressure fuel and oxidizer turbopumps. It incorporates a 100-

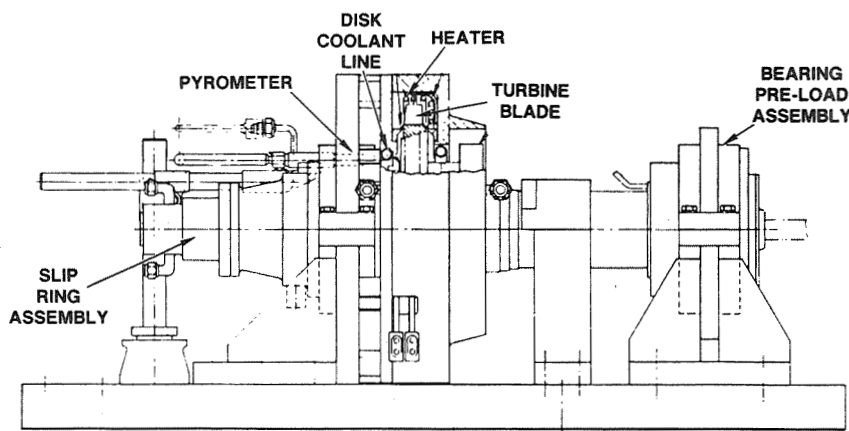

Fig. 6. Turbine Blade Monitoring With Pyrometer

channel slip ring assembly, soft bearing supports for excursion through critical speeds, and a bearing preload assembly, shown to the right in the figure. Modifications to the whirligig to meet the needs of this test program are incorporation of resistance heating elements in the turbine blade passage, and the addition of a coolant ring to maintain acceptable disk temperatures. The fiberoptic pyrometer monitors the blades through a window in the blade passage housing and is mounted to a support with 5 degrees of freedom: X, Y, Z, pitch, and yaw.

Monitoring turbine blade health is accomplished by monitoring thermal radiation emitted from the hot blade. Figure 7 illustrates operation of the pyrometer. Radiation emitted by the blades is focused by

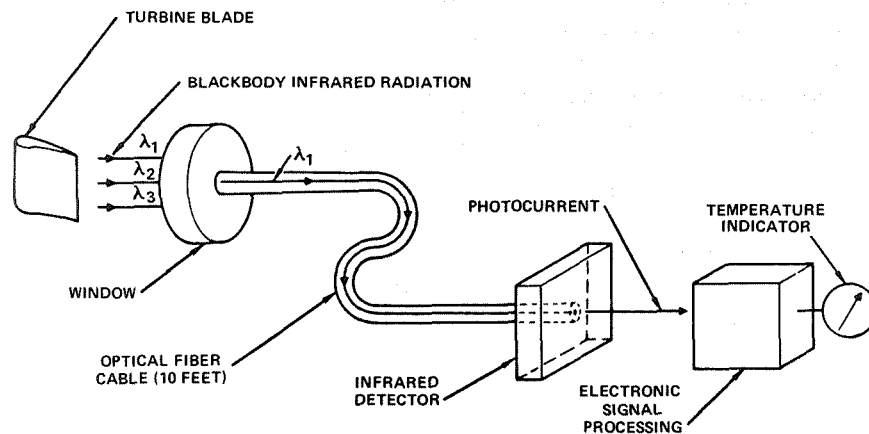

Fig. 7. Optical Pyrometer

the pyrometer's lens on fiberoptics, which transmit the radiation to a silicon photodetector. The photodetector provides an electrical signal proportional to turbine blade temperature, which is then processed to determine blade temperatures, blade temperature history, the presence of hot or cold blades, etc. Frequency response time of the associated electronics for the pyrometer must be high to accommodate the high blade passing frequency found in the turbopumps.

Environment compatibility is required only for the deflectometer and pyrometer. The isotope wear detector is a between-flight measurement and therefore will not be exposed to the operating turbopump environment. The test fixture shown in Fig. 8 evaluates the ability of the deflectometer to withstand the physical environment near the turbopump bearings. The test fixture is capable of pressures to 5000 psig and temperatures from cryogenic to 500 F, which simulate the extremes found in the bearing vicinity.

While the temperatures and pressure vary, the deflectometer is monitoring a stationary target mounted to its tip to register any changes in output that may occur during test. The test fixture shown in Fig. 9 evaluates the pyrometer's ability to withstand the environment found in the turbopump turbine. The test fixture is an exhaust duct to another tester that utilizes the combustion

products of hydrogen and oxygen. Temperatures in the flow passage reach 2000 F at pressures up to 3000 psig, which exceed current SSME high pressure fuel turbopump operating conditions. The pyrometer monitors a stationary, thermocoupled target on the opposite side of the flow channel from any one of three orientations: 20, 45, or 70 degrees. The actual surface that the pyrometer monitors is removable so that a variety of representative turbine blade materials can be viewed.

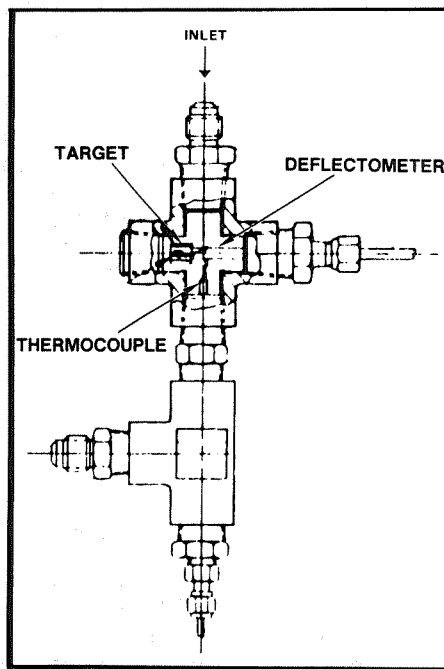

Fig. 8. Deflectometer Environment Tester

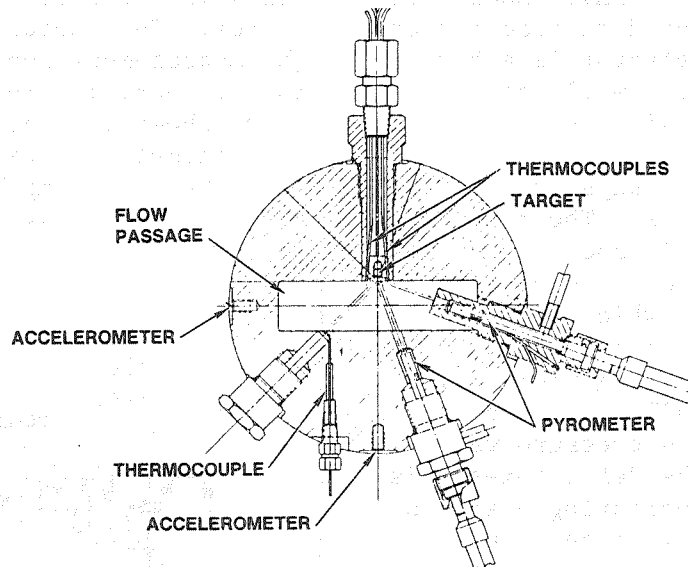

Fig. 9. Pyrometer Environment Tester

Cooling of the pyrometer, which has a maximum allowable face temperature, is achieved by a low level gaseous nitrogen purge.

Incorporating the CMS into Turbopumps

The optimum starting point in CMS design for a turbopump is, of course, at the beginning of the turbopump design itself. One program currently being directed by NASA Lewis is doing just that: Integrated Control and Health Monitoring for the Orbital Transfer Vehicle engine system. However, existing turbopump systems stand to gain significant savings in cost and turnaround time by retrofitting a CMS where possible. During the course of the current program, design layouts were developed for the SSME high pressure fuel and oxidizer and the MK48-F turbopumps, which incorporated the fiberoptic deflector, fiberoptic pyrometer, and isotope wear detector.

A representation of retrofitting a CMS in an existing turbopump design is shown in Fig. 10 and 11

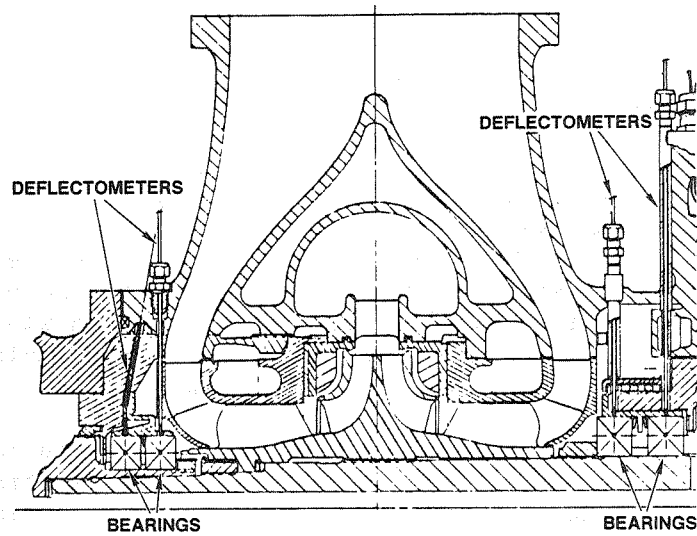

Fig. 10. Fiberoptic Deflectometers Monitoring SSME HPOTP Bearings

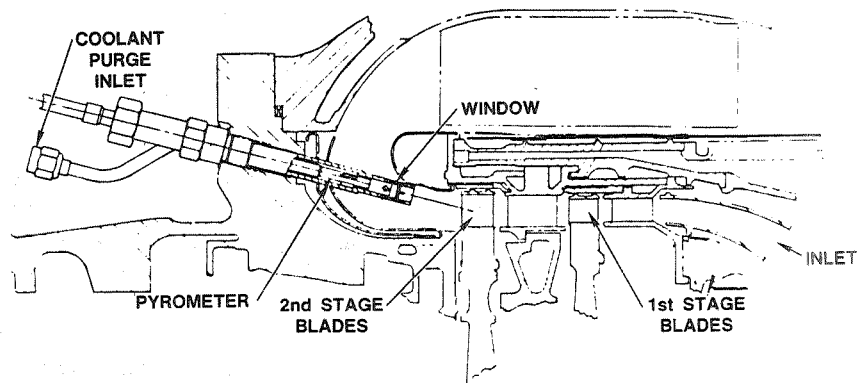

Fig. 11. Fiberoptic Pyrometer Monitoring SSME OPOTP Second-Stage Turbine Blades

for the SSME high pressure oxidizer turbopump. Shown in Fig. 10 is the design layout for installation of the fiberoptic deflectometer to monitor bearing condition. The fiberoptic probes penetrate the turbopump housing in the vicinity of the pump inlet

volute, continue through the housing, and penetrate the bearing isolators before obtaining an unobstructed view of the bearing race surface.

Figure 11 illustrates installation of the fiber-optic pyrometer for monitoring the second-stage turbine blades. The pyrometer is installed in the flange and penetrates the turbine discharge liner before being able to view the turbine blades via a window mounted in the sight tube. A coolant purge maintains acceptable temperatures in the pyrometer.

The isotope wear detector monitors radiation emitted by the irradiated bearing, which penetrates the turbopump housing in all directions. Readings with the sensor can be taken using a hand-held detector or by placing the detector in a simple, temporary mounting fixture in the vicinity of the bearings. Therefore, no design modifications are required to incorporate the isotope wear detector.

Conclusion: Saving Time and Money
With a CMS

The ever-increasing demands placed on rocket engine performance and life expectancy establish the need to develop and incorporate a condition monitoring system into the engine system. The efforts put forth during this program to date have laid the groundwork and developed the data base from which all condition-monitoring systems can benefit. Common failure modes present in all rocket engine systems have been identified, screened, and categorized. Conventional to novel and state-of-the-art sensing technologies have been identified and correlated to the failure modes. Sensor signal and condition monitoring algorithms have been evaluated for their ability to directly determine the occurrence of the particular failure mode, and in predicting the component's remaining useful life. Testing is underway at this writing of the CMS in a laboratory setting.

Reductions in engine maintenance costs and turn-around time are easily recognized once the CMS is implemented. For instance, the estimated turnaround time savings alone for the SSME upon implementation of a CMS is better than 50 percent. This translates into a significant dollar savings over the useful life of the engine once launch delays, labor, and hardware requirements are considered.

Valuable knowledge of engine operating conditions can also be obtained through additional manipulation of the data provided by the CMS. Use of this knowledge can improve engine control capability, new component performance, and assessment of development engine performance. Knowledge of engine safety is a direct, significant output from the use of this information when used in conjunction with condition data provided by the algorithms. System safety information is perhaps the most important product of the CMS.

Bibliography

MacGregor, Charles, A., Reusable Rocket Engine Maintenance Study, Final Report, NASA CR-165569, January 1982.