



**AALBORG UNIVERSITY**  
DENMARK

**Aalborg Universitet**

## **Reversing the Energy Trend in Mobile Networks**

*Equipment Replacement for Increased Capacity at a Fraction of the Energy*

Micallef, Gilbert; Mogensen, Preben; Scheck, Hans-Otto; Louhi, Jyrki

*Published in:*

IEEE VTS Vehicular Technology Conference. Proceedings

*DOI (link to publication from Publisher):*

[10.1109/VETECF.2011.6092839](https://doi.org/10.1109/VETECF.2011.6092839)

*Publication date:*

2011

*Document Version*

Early version, also known as pre-print

[Link to publication from Aalborg University](#)

*Citation for published version (APA):*

Micallef, G., Mogensen, P., Scheck, H-O., & Louhi, J. (2011). Reversing the Energy Trend in Mobile Networks: Equipment Replacement for Increased Capacity at a Fraction of the Energy. *IEEE VTS Vehicular Technology Conference. Proceedings*. <https://doi.org/10.1109/VETECF.2011.6092839>

### **General rights**

Copyright and moral rights for the publications made accessible in the public portal are retained by the authors and/or other copyright owners and it is a condition of accessing publications that users recognise and abide by the legal requirements associated with these rights.

- Users may download and print one copy of any publication from the public portal for the purpose of private study or research.
- You may not further distribute the material or use it for any profit-making activity or commercial gain
- You may freely distribute the URL identifying the publication in the public portal -

### **Take down policy**

If you believe that this document breaches copyright please contact us at [vbn@aub.aau.dk](mailto:vbn@aub.aau.dk) providing details, and we will remove access to the work immediately and investigate your claim.

# Reversing the Energy Trend in Mobile Networks

## Equipment Replacement for Increased Capacity at a Fraction of the Energy

Gilbert Micallef<sup>(1)</sup>

<sup>(1)</sup>*Aalborg University,  
Aalborg, Denmark.*

Preben Mogensen<sup>(1,2)</sup>,

<sup>(2)</sup>*Nokia Siemens Networks,  
Aalborg, Denmark.*

Hans-Otto Scheck<sup>(3)</sup>,

<sup>(3)</sup>*Nokia Siemens Networks,  
Kista, Sweden*

Jyrki Louhi<sup>(4)</sup>,

<sup>(4)</sup>*Nokia Siemens Networks,  
Espoo, Finland*

*Abstract* – In order to meet the expected boost in mobile data traffic, mobile network operators are planning and upgrading the capacity of their networks. Through a previous study it has been shown that over a period of eight years, different network upgrade strategies have a different impact on the energy consumption and cost of the network. However, irrespective of the upgrade strategy, all lead to an overall increase in the energy consumption of the network. This is based on the assumption that all sites are equipped with the same version of the equipment. In reality, it is likely to find a variety of equipment generations at different base station sites. This paper extends the previous study by considering a realistic equipment replacement strategy. In addition to considering three equipment generations, a number of sites are also upgraded to remote radio head, which reduces the energy consumption even further. Results show, that over the evolution period, it is in fact possible to boost capacity while maintaining or even reducing the energy consumption of the network. For the macro-only upgrade case, a reduction of 9% is experienced between the first and the last year. For the joint macro-pico case, a reduction in energy consumption of 41% is noted. Such reductions are well in line with what mobile network operators are aiming at achieving over the next years.

*Keywords-component; energy saving, network evolution, equipment replacement, remote radio head, base station site.*

### I. INTRODUCTION

An increasing number of mobile network operators (MNOs) have joined the bandwagon of making environmental pledges for reducing their carbon footprint. Even though not bound by any industrial commitment, network operators go further by setting specific targets, generally accompanied by a timeline [1, 2, 3]. Besides the obvious benefit of reduced energy costs, network operators are aware of the importance, visibility, and competitive edge that being green and environmentally conscious can provide. Through their environmental statements, MNOs declare that the operation of their networks is the main contributor towards their carbon footprint, with some operators estimating that this amounts to more than 80% [2]. Because of this, MNOs and equipment vendors alike are looking at possible methods for reducing the energy consumption of mobile networks, with special focus directed towards base station sites.

Over the last years this area of research has attracted major interest, with a number of projects [4] [5] yielding a variety of publications and deliverables. Amongst others, the main topics being looked at for reducing the energy consumption of mobile networks include: self optimizing networks [6], hardware improvement [5], network architecture, improved spectral efficiency and a variety of energy saving features [7].

More important than reducing the energy consumption, MNOs are engaged in planning and dimensioning their networks. This is done in an attempt to keep up with the boost in mobile traffic, which according to recent figures, has continued to grow by a factor of 2.4 in 2010, exceeding projected expectations [8]. Based on the current status of their networks, available spectrum, and other issues, operators consider different strategies for upgrading their network. These would include: the upgrade of existing macro sites, the deployment of small high capacity cells, and the eventual roll-out of the next network layer, specifically LTE. Since different upgrades require specific equipment and configurations, each has a different impact on the energy consumption and efficiency of mobile networks.

In a previous study [9], the evolution of a mobile network over a period of eight years is investigated through a case study. This is done to compare two different network upgrade strategies, with special focus given to the energy consumption and efficiency. Results show that a joint macro-pico upgrade solution is more energy efficient than a macro-only upgrade strategy [9]. Nonetheless, both options show a trend of increasing energy consumption with traffic throughout the evolution. This comes from the fact that all sites are assumed to be equipped with the same version of the equipment. Inherently, additional upgrades or sites result in increased energy consumption.

Due to network rollout strategies and upgrades along the years, MNOs are likely to be running and supporting different versions or generations of base station equipment. In terms of energy consumption, older versions are considerably less efficient. This means that for MNOs, the replacement of such equipment is a further opportunity for achieving considerable energy savings.

This paper extends the analysis of the previous study by including the impact of: an equipment replacement strategy, a more extensive energy model, upgrading some sites with remote radio head (RRH), and no cooling. The objective is to determine whether or not it is realistically possible to upgrade the capacity of a network, over a period of time, while consuming less or at least the same amount of energy as in the first year. This can be used as a measure to verify whether or not it is possible for MNOs to achieve their energy targets.

The paper is organized as follows: Section II introduces the equipment within a base station site, with special focus on the ones considered in this paper. In Section III the energy modeling and assumptions are presented. This is followed by an overview of the simulation and evolution scenario, which are accompanied by a set of results, conclusions, and possible future extensions.

## II. BASE STATION SITE

In order to provide mobile coverage on a national basis, network operators are required to deploy a large number of base station sites. These sites house a variety of equipment, some of which are responsible for establishing a communication link between the mobile users and the rest of the network, while additional equipment is necessary for supporting and maintaining the site. Figure 1 provides a simple overview of some of the main components within a macro base station site, also highlighting (green) the ones that are considered in this study.

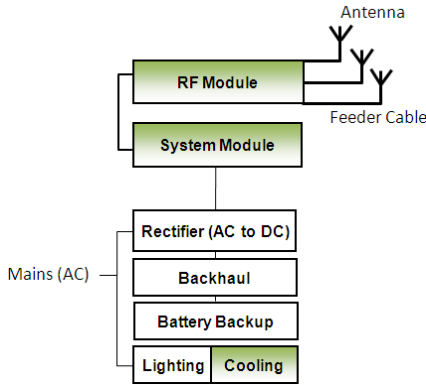

Figure 1 – Overview of the main components in a macro base station site, highlighting the ones which the energy model focuses on.

Every couple of years, advancements in technology allow for compact, flexible, and efficient equipment, loaded with an array of new features to hit the market. Even though always improving, base station sites remain overall highly inefficient. This is partly due to the need of power amplifiers to compromise efficiency for linearity [10]. Average power amplifier efficiency is further decreased due to a lower operational efficiency at lower load levels. Future power amplifier architectures are likely to focus on this aspect, improving the efficiency even further, especially at average and low load levels. In addition to the improvement of individual components, manufacturing procedures allow for base station units to be made more compact, supporting all RF functionalities of a three sector macro site within a single portable unit. Because of such improvements, equipment replacement becomes a natural process for MNOs. Besides, from a cost perspective, it is also unfeasible to maintain and support different equipment versions.

In addition to network and operational advantages, improvement in the hardware also allows the equipment to operate at higher temperatures. This reduces, or in many regions completely eliminates, the need for active cooling (air conditioning), which is believed to be responsible for at least 25% of the energy consumption in a base station site [11]. Besides, new equipment is also packed with a range of software features that makes it more versatile. Such features allow network operators to manage and optimize the operation of their networks, improving performance and energy consumption even further. In this specific case, energy gains from such software features are not considered.

Reducing the energy consumption of base station sites can also enable further initiatives. As the consumption falls below a certain threshold, this could for example make the generation

of energy through renewable sources at the site more affordable and attractive, reducing consumption even further, while also making site deployment in developing countries easier.

## III. BASE STATION ENERGY MODELING

### A. Reference Model

In order to estimate the energy consumption of a network with sites having different equipment versions and configurations, an extended energy model is required. The first version of the model [9] is based on the RF and system module, considering site configuration parameters such as: number of sectors, transmission power, and site load. The model also includes the notion that the load of a base station site is only weakly linked to the overall energy consumption. This means that for a large drop in load, the energy consumption drops by a relatively smaller amount.

### B. Extended Model

The model is extended to support different base station equipment versions, additional input configuration parameters, and a number of possible site upgrades. Throughout the paper, when considering the evolution of the network through site replacement and upgrades, it is only the operational energy consumption of the sites that is considered. This means that the energy consumed during the manufacturing process and transport of the equipment, referred to as ‘*embodied energy*’, is not included. The model for pico sites is based on the same energy model which is appropriately scaled.

#### 1) Different Equipment Versions

This paper focuses primarily on the evolution of existing UMTS/HSPA networks. Since their launch, a leading mobile equipment vendor has released at least three major equipment generations. For simplicity, throughout this paper these are referred to as 1<sup>st</sup>, 2<sup>nd</sup>, and 3<sup>rd</sup> equipment generation, with the 1<sup>st</sup> referring to the oldest, and so on. The 1<sup>st</sup> equipment version is bulky, requiring a larger space for the equipment, and its active cooling system. In comparison to the most recent generation (3<sup>rd</sup>), the equipment is in itself extremely energy inefficient, which is made even worse by the impact of active cooling. Differences between the 2<sup>nd</sup> and 3<sup>rd</sup> equipment generations are less drastic, with the most recent generation being more energy efficient while offering more features and operational flexibility.

Equipment Generation	Energy Factor	Cooling Factor
3 <sup>rd</sup> Generation	0%	0%
2 <sup>nd</sup> Generation	+20%	0%
1 <sup>st</sup> Generation	+100%	+30%

Table 1 – Energy and cooling factors used for different equipment generations. These factors are added to the energy model which is based on the 3<sup>rd</sup> generation, and are based on discussions with experts at Nokia Siemens Networks.

The reference energy model is based on the 3<sup>rd</sup> equipment generation. This is extended by modeling the older versions through the addition of energy consumption factors, which are presented in Table 1. A cooling factor is also included, but only the 1<sup>st</sup> equipment generation is affected. These factors and other modeling values are selected through internal dis-

cussions with Nokia Siemens Networks professionals. It is important to note, that throughout the evolution period considered, additional efficiency improvements to the equipment can be expected. Since the extent of these improvements is difficult to quantify, these are not included in this specific study. This also allows for the presented results not to be overly optimistic.

### 2) Upgrade to Remote Radio Head Sites

Besides replacing the equipment, this study also considers the option of upgrading sites with remote radio head (RRH) units. Long feeder cables connecting the radio module to the antennas are estimated to cause a signal attenuation of about 3dB. This means that for a specific transmission power at the antenna, the radio module has to output twice that amount. This inherently increases the energy consumption of the site, providing an opportunity for improving the energy efficiency even further. By placing the radio equipment close to the antenna, the overall losses are reduced, but not completely removed. Additional losses come from the jumper cables, connectors, and splitters used. Due to a number of practical restrictions, the upgrade of RRH is not always possible at every site. Such restrictions may include: positioning and access to the RF module, rental agreements, and visual pollution. This is factored in by limiting the number of sites that can be upgraded to a specific percentage - 60% in this study.

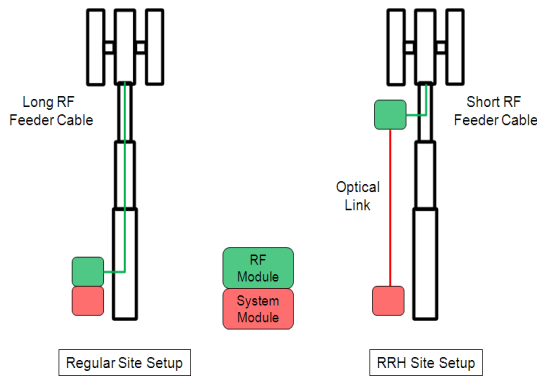

Figure 2 – The upgrade of macro sites to RRH involves moving the RF module as close as possible to the antenna in order to reduce feeder cable loss.

## IV. NETWORK EVOLUTION SCENARIO

In order to cope with the expected increase in data traffic, existing UMTS/HSPA networks require a number of major capacity upgrades over the next years. Through a previous case study [9], two upgrade strategies have been compared for the evolution of an actual network area.

### A. Simulation Overview

Through statistics about the country and area being investigated for the case study, the number of expected mobile broadband users during the busy hour is estimated. This is set as the number of users to be placed within the network area for the first year (2010). For subsequent years the penetration of mobile broadband is assumed to increase steadily from 15% in 2010, to a maximum of 60% in 2017. The traffic distribution of the network for the busy hour is determined through network statistics. This allows for a more realistic distribution of the traffic, highlighting the sites that need upgrading.

For each year in the evolution period, users require a minimum downlink data rate. A user is assumed to be satisfied if the achievable data rate, after all resources have been distributed among users within the cell, is equal to or larger than the minimum set data rate. For all simulation cases, the objective of the network is to have a user satisfaction rate equal to or greater than 95%.

Simulations are based on a full buffer traffic model, meaning that all users within a cell have data to download. A resource management algorithm shares the available resources between all users of a cell. This is done in a way that prioritizes user satisfaction, by first assigning resources to users with a good channel (SINR), thus requiring fewer resources to achieve the minimum requested data rate. Since full load is assumed, if all users achieve the minimum data rate, any remaining resources are shared amongst cell users in a round robin fashion.

With regards to the evolution of the network, two main strategies are considered. In the first case, a macro-only upgrade path is considered, where macro sites are first upgraded to having two or three 5MHz carriers on the same 2100 MHz band. This is based on available spectrum that the specific operator actually has. If additional capacity is required, sites are then upgraded further to enable 2x2 MIMO. Given the site components that are considered by the energy model, the additional equipment required to support a second parallel transmission channel, practically doubles the energy consumption of the site. The second evolution option is a joint macro-pico deployment strategy, in which a number of pico sites, operating on a dedicated channel, are deployed each year to offload macro sites and reduce the need for macro site upgrades. The position where pico sites are deployed is based on a metric that considers traffic density and perceived SINR [9]. This results in pico sites being deployed close to the edge (lower SINR) of cells having large volumes of traffic.

Figure 3 shows the configuration of the network for both upgrade strategies at the final year of the evolution [9]. With regard to the energy consumption, results show that for both cases, when comparing the first year of the evolution with the last, network upgrades result in increased energy consumption. For the joint macro-pico deployment case this increase is of 30%, which is less than the 75% increase observed for the macro only upgrade strategy [9].

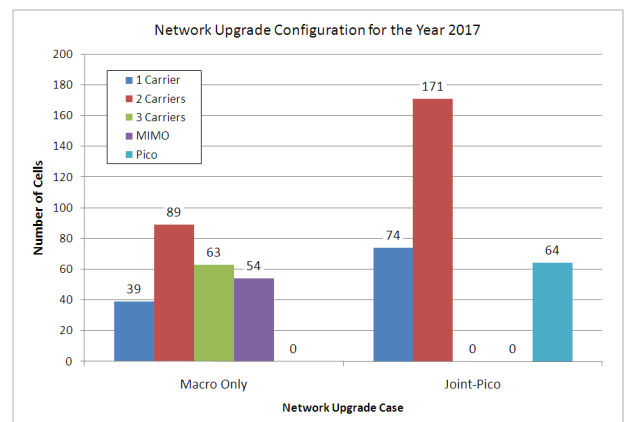

Figure 3 – Network evolution results, from [9], showing the configuration of the network in the final year of the evolution. The figure highlights how joint macro-pico deployment reduces the number of required macro upgrades.

### B. Equipment Replacement

The first part of this study adds different site equipment versions to all base station sites. In the first year, a combination of 1<sup>st</sup> and 2<sup>nd</sup> equipment generations is considered. The selection for how to divide between the two is based on actual statistical data from a specific network. This data shows that up until 2010, only about 40% of the sites have been upgraded to the 2<sup>nd</sup> equipment generation. Throughout the years, this is assumed to gradually evolve, seeing also the introduction of the 3<sup>rd</sup> equipment generation. In the final year of the evolution period this is assumed to be at 85% of all base station sites. The 1<sup>st</sup> equipment generation is assumed to be completely phased out by 2014, leaving the network with two main equipment generations. The equipment replacement strategy (Figure 4) is based on the assumption that MNOs are also required to optimize their costs, making a full network replacement for energy saving purposes unrealistic.

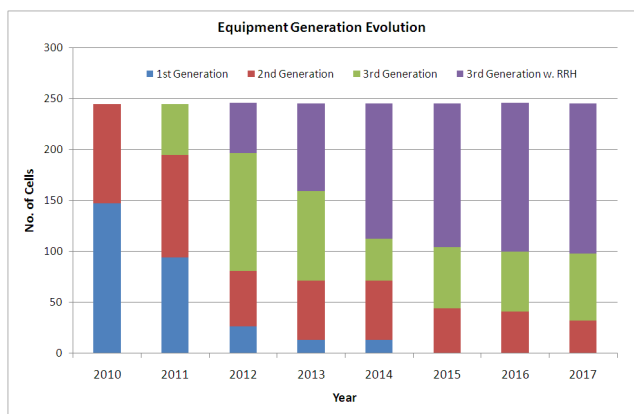

Figure 4 – An overview of how the equipment replacement strategy and upgrade to RRH is assumed to be carried out over the evolution period.

### C. Upgrades to Remote Radio Head

While ideally all sites should be upgraded with RRH units, this is not always possible. In this study, the upgrade of macro sites to RRH is limited to no more than 60% of all sites (Figure 4), and it is assumed that sites with RRH upgrades use the 3<sup>rd</sup> generation of the equipment. Instead of a 3dB signal loss, sites upgraded to RRH are assumed to suffer a loss of 1dB. This is used to estimate the output power required at the RF module in order to ensure a specific transmission power at the antenna. In the case of pico sites, a similar 1dB loss is assumed.

## V. RESULTS

In this case study a network evolution ranging from 2010 to 2017 is considered. While the graphical results show how the energy consumption evolves throughout the period, the main focus is to compare the first year with the last. In order to show the impact of each assumption, the results are built gradually, each time introducing an additional factor: first starting with equipment replacement, followed by the upgrade to RRH, and then finally the impact of cooling. This is carried out for both the macro-only and the joint macro-pico upgrade cases.

Prior to any equipment replacement, the energy consumption of the network for both upgrade options is calculated using the extended version of the energy model. The main difference from the model used in [9] is the inclusion of feeder cables

loss, which increases the required output power at the RF module. With the original version of the energy model, the difference in consumption between the first year and the last is +75% [9], which with the extended model increases further to +102%. These can be noted in the energy trends shown in Figure 5.

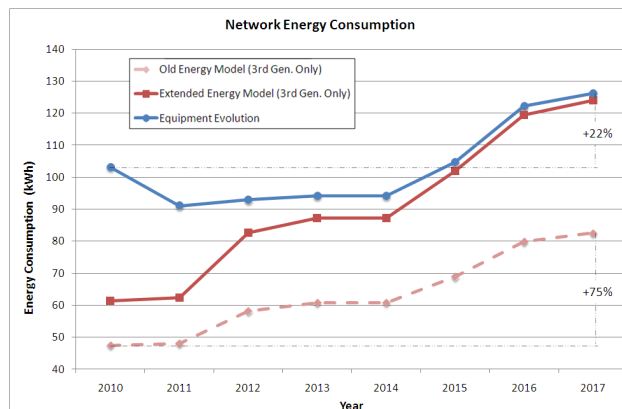

Figure 5 – Energy consumption trend by assuming different energy model assumptions, and an equipment evolution strategy.

Then an equipment generation is assigned to all base station sites, which evolves throughout the study as shown in Figure 4. This means that compared to the original energy evolution trend in [9], in which all sites are equipped with the 3<sup>rd</sup> equipment generation, the presence of older equipment increases the energy consumption of the network. The greatest increase is noted in the first year, when the network is for the greater part equipped with 1<sup>st</sup> generation equipment. As noted in Figure 5 this increase in energy consumption reduces the difference between the first year and the last to a mere +22% (to note that at this point the impact of cooling is not included). The trend shows an initial drop in the first year, which results from considerable equipment replacement and few upgrades. This is then noted to slowly pick up again, peaking with the introduction of MIMO in the year 2015.

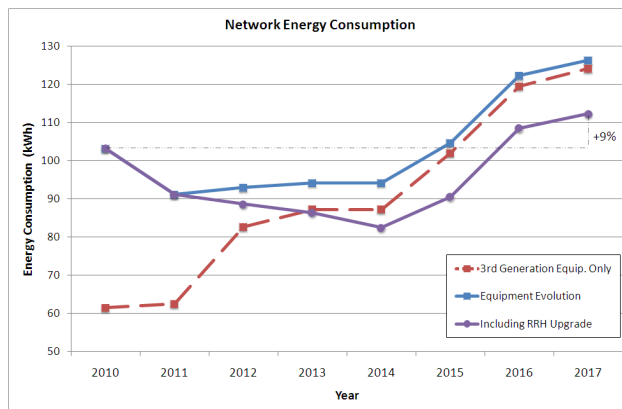

Figure 6 – The upgrade of sites to RRH is noted to reduce the energy consumption, which increases as more sites are upgraded.

Next is to gradually include the upgrade of macro base station sites to RRH. Whereas site replacement increases the energy consumption, the upgrade to RRH has the effect of reducing the energy consumption. In comparison to the replacement of equipment, the energy trend for the network with RRH upgrades shows further reductions in energy consumption as the number of RRH site upgrades increases along the years. In

Figure 6, it can be noted that the increase in energy consumption between the first and the last year is limited to just +9%. Compared to the initial +102%, site replacement and upgrade with RRH are noted to almost balance out the energy trend.

Due to a lower operating temperature, 1<sup>st</sup> generation equipment requires active cooling. This has a considerable impact on the overall energy consumption of the site, meaning that the replacement of such equipment leads to additional indirect energy savings. Since this is only limited to the 1<sup>st</sup> generation of the equipment, the inclusion of active cooling increases the energy consumption of the network, in the period before its replacement. Results, presented in Figure 7, show that the impact of active cooling in the first year makes the energy consumption higher than that in the last year. This means that over the entire evolution period, the network has a net reduction in energy consumption by about 9%.

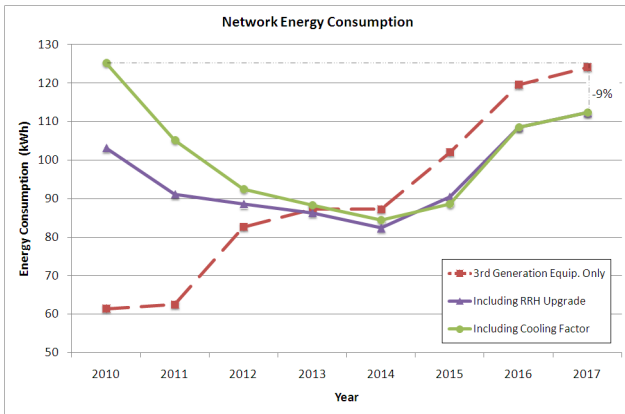

Figure 7 – The addition of cooling is noted to increase the energy consumption in the first years even further, resulting in a net energy decrease.

The previous steps are repeated for the joint macro-pico upgrade case. When assuming all sites to have the same generation of the equipment, this option outperforms the macro-only option [9]. Hence, it is expected that after including all upgrades and assumptions considered in this study, the overall energy consumption is reduced even further. In this case, year after year the number of sites increases due to the deployment of additional pico sites. The site replacement and upgrades to RRH are carried out in a way to keep the same equipment percentages as those considered in the previous case. The results for this case are summarized and compared with the macro-only upgrade case in Table 2.

Assumption	Energy Trend (Macro-Only Case)	Energy Trend (Joint macro-pico Case)
3 <sup>rd</sup> Generation Only	+102%	+44%
Equipment Evolution	+22%	-15%
Upgrade to RRH	+9%	-28%
Including Cooling	-9%	-41%

Table 2 – Table of results showing the energy trend (going from 2010 to 2017) for both evolution cases, under the different assumptions investigated.

The numbers confirm that for the joint macro-pico case, the reductions in energy consumption are substantial. With the assumption of equipment replacement alone, the energy consumption of the network over the entire period is noted to be reduced by 15%. With the addition of RRH upgrades and the impact of no active cooling this reduction is improved further to 41%.

## VI. SUMMARY AND CONCLUSIONS

Previous work on the evolution of mobile networks is primarily focused on comparing different upgrade options for carrying the expected increase in mobile data traffic. This is carried out under the assumption that all sites are equipped with the same type of equipment. This paper provides an extension by also considering the replacement of old equipment, upgrading sites to RRH, and avoiding active cooling.

When comparing the first year of the evolution with the last, results clearly show that considering different equipment versions has a major impact on the energy consumption trend of the network. For the case of macro-only upgrades, when considering all three factors, an overall reduction in the energy consumption of 9% is noted. On the other hand, for the joint macro-pico case, a reduction of 41% is noted. While such reductions are considerable, it is important to point out that throughout the evolution the capacity of the network has been improved. This study shows that by considering an equipment replacement strategy, the energy trend of a mobile network over a number of years can, not only be balanced out but also reduced. By having observed a reduction in the energy consumption by around 40%, this is a good indication that the targets set by MNOs are in fact realistic.

It is, however, important to note that this study focuses on a single layer of the network (3G). With MNOs expected to roll out their LTE layers within the next 2 to 3 years, the energy consumption of the network is expected to increase significantly, especially due to the fact that 2x2 MIMO is considered as default. For the first years, when the carried traffic is still low, this will reduce the energy efficiency of the network even further. A future study will look at the performance and energy trend of a mobile network by also considering the evolution on multiple radio access layers.

## REFERENCES

- [1] “Pressing Forward” – Vodafone Group Plc Sustainability Report, March 2010.
- [2] Telenor – Operational Efficiency <http://www.telenor.com/en/corporate-responsibility/environment-and-climate/operational-efficiency/>
- [3] Orange – “Towards a Greener World” [http://www.orange.com/en\\_EN/responsibility/environment/](http://www.orange.com/en_EN/responsibility/environment/)
- [4] “OPERA-Net, Power Efficiency Network” – Celtic Eureka funded R&D European Project, [www.opera-net.org](http://www.opera-net.org) (verified Feb 2011).
- [5] W. Tuttlebee, S. Fletcher, D. Lister, Tim O’ Farrell, J. Thompson, “Saving the Planet – The rationale, realities and research of Green Radio”, The Journal, 3Q 2010.
- [6] Nokia Siemens Networks, “Self-Organizing Network (SON) – Introducing the Nokia Siemens Networks SON Suite – An efficient, future proof platform for SON”, White Paper, October 2009.
- [7] G. Micallef, P. Mogensen, HO. Scheck – “Dual-Cell HSPA for Network Energy Saving”, IEEE Vehicular Technology Conference 2010, Taipei, May 2010.
- [8] “CISCO Visual Network Index: Global Mobile Data Traffic Forecast Update, 2010-2015”, White Paper, February 2011.
- [9] G. Micallef, P. Mogensen, HO. Scheck, E. Lang, “Energy Efficient Evolution of Mobile Networks – Macro-Only Upgrades vs. a Joint-Pico Deployment Strategy”, IEEE Vehicular Technology Conference 2011, Budapest, May 2011. (ACCEPTED)
- [10] ABIresearch, “Equipment and RF Power Device Analysis for Cellular and Mobile Wireless Infrastructure Markets”, 4Q 2010.
- [11] S. Roy, Global Marketing, “Energy Logic for Telecommunications”, Emerson – Network Power, White Paper, September 2008.