

JERZY FEDOROWSKI & ROBERT K. JULL

REVIEW OF BLASTOGENY IN PALAEOZOIC CORALS AND
DESCRIPTION OF LATERAL INCREASE IN SOME UPPER
ORDOVICIAN RUGOSE CORALS

Abstract.—Almost all blastogeny in colonial rugose and tabulate corals involves lateral increase. Axial increase is rare and peripheral increase, which uncommonly occurs in both solitary and colonial corals, is regarded as a multiple type of rejuvenescence. Coenenchymal increase is known only in heliolitid corals. During lateral increase in fasciculate and massive colonies, offset and parent are separated by either a partition which is interpreted as formed by a continuous sheet of basal ectoderm between offset and parent polyps, or by a dividing wall which is formed by two entirely separate polyps.

Lateral increase in species of *Favistina* and *Palaeophyllum* from the Upper Ordovician of eastern North America involves offsets which are separated from the parent corallite by a dividing wall. Axial planes of the offsets are oriented towards the axis of parent corallites, with the counter septum located on the peripheral wall. Septal insertion in general shows a rugosan pattern. Tertiary septa are present in two specimens of *Palaeophyllum*.

INTRODUCTION

Although studies of corallite development in Palaeozoic corals date back to the late nineteenth century, it is only within the past fifteen years that a number of studies have appeared which contain a significant volume of data on corallite development and some utilization of this information on taxonomic and phylogenetic problems. The advent of these studies largely coincides with the development of new techniques for the detailed study of hystero-ontogeny, especially the use of closely spaced acetate peel impressions. Notable early studies of corallite development in Palaeozoic corals include the work of Lindström (1899) on *Heliolites*, Smith (1916) on *Lonsdaleia*, Smith & Ryder (1926; 1927) on *Corwenia* and *Stauria*, and Smith & Tremberth (1929) on *Entelophyllum*. It was through these studies, together with that of Koch (1883) and Hill (1935) that our basic knowledge of corallite development and the terminology associated with it was developed.

The purpose of this paper is to assess work to date on the subject and to suggest some aspects which appear to be emerging. The second part of this paper is devoted to the description of blastogeny in some Upper Ordovician species of *Palaeophyllum* and *Favistina* from eastern North America. These are the first Ordovician rugose corals in which blastogeny has been described. Of particular interest in selecting these corals for study was their similarity to a number of genera of tabulate corals of similar age.

Taxonomic treatment of the material has not been attempted. We have used Flower's (1961) interpretation of species of *Favistina* in identifying our specimens of this genus. We leave it for others to judge if Browne (1965) is correct in suggesting that *Favistina* is junior subjective synonym of *Cyathophylloides*. The specimens of *Palaeophyllum* from Anticosti Island are only tentatively identified. T. E. Bolton, Geological Survey of Canada, is currently studying the coral faunas from this area.

The origin of specimens used in this study is indicated by the following code associated with catalogue numbers: BM — British Museum (Natural History), London; SM — Sedgwick Museum, Cambridge; GSC — Geological Survey of Canada, Ottawa.

Specimens studied

Specimens originating from the British Museum (Natural History) are all early collections and stratigraphic details associated with them are relatively out of date. Since our interpretation of the horizons in current terminology might be in error, the original details with the specimens are included as well.

Favistina stellata (Hall, 1847)

BM R602A, B, C; BM R24736A, B: "*Columnaria stellata* Hall, Ordovician, Cincinnati Group, Bardstown, Kentucky, USA". These five specimens almost certainly come from the "Bardstown Coral Reef" of Foerste (1909). If Browne's correlations (1964) are correct, the specimens originate from the Richmondian Saluda Member, Whitewater Formation. Earlier authors, including Flower (1961) consider correlations to be with the underlying Liberty Formation. The locality is near Bardstown, County Nelson, north-west Kentucky. BM R36207: "*Columnaria calicina?* Nicholson, Ordovician, Caradoc (Cincinnati Group), Bardstown, Kentucky.". The specimen probably originates from the same horizon as the previous specimens. As noted below, corallites are slightly larger than average compared with other specimens of *F. stellata* but it nevertheless probably belongs with this species rather than with *C. calicina* as originally identified.

Favistina calicina (Nicholson, 1875)

BM R31861: "*Columnaria calicina* Nicholson, Upper Ordovician Richmond Beds, Basal Whitewater Formation, Streetsville, Ontario, Canada." This specimen almost certainly originates from the Richmondian Upper Mem-

ber (Meaford) of the Georgian Bay Formation (see Liberty, 1969). The locality is on or near the shore of Lake Ontario, immediately west of Toronto. BM R56435A, B, C: "*Columnaria calicina*, Ordovician, Caradoc (Cincinnati Gp.) Credit River, Western Ontario, Canada.". The specimens are from the same horizon and general locality as the previous specimen.

BM R21515: Identical locality and horizon as the previous one, only the specimen was erroneously identified as *Columnaria stellata*.

Details on the following specimens were supplied by T. E. Bolton, Geological Survey of Canada. The material all originates from the Richmondian Vauréal Formation on Anticosti Island, Gulf of St. Lawrence, Quebec, Canada.

Palaeophyllum vaurealensis Twenhofel, 1928 *sensu* Bolton, 1972
GSC 31352: Main highway in Bay Martin — Ste. Marie valley creek bed.

Palaeophyllum cf. *vaurealensis* Twenhofel, 1928

GSC 31353: Beaver Cove road, 0.9 miles north of main highway. GSC locality 66778.

Palaeophyllum sp.

GSC 31354: Same locality as previous specimen.

GSC 31355: Main highway east of Loon Lake — Beaver Lake road. GSC locality 76087.

ACKNOWLEDGMENTS

We are very grateful to Dr. B. Rosen, British Museum (Natural History), Dr. T. E. Bolton, Geological Survey of Canada, and Dr. C. L. Forbes, Sedgwick Museum, Cambridge, for the loan of material for this study. One of us (RKJ) deeply appreciates the access to facilities and kind hospitality extended to him as a visitor to the Sedgwick Museum while this paper was being prepared. Finally, we thank Mr. Antoni Pietura, Palaeozoological Institute, Polish Academy of Sciences, Poznań Branch, for taking photographs for this study.

TERMINOLOGY

Many of the papers associated with the definition of terms on blastogeny are listed above. Others include Hill (1956), Rózkowska (1960), Fedorowski (1965), Jull (1965), Oliver (1968) and Coates & Oliver (1973). These and other studies have resulted in a proliferation of terms, many of which have been misused. The following list, which contains only a few newly suggested names, seems to include the most useful and least ambiguous terms. We otherwise follow the definitions of Hill (1956).

Just as *astogeny* relates to overall colony development, *blastogeny* is associated with the phenomena of development of the *offset* (or asexually developed corallite in the colony) from the parent corallite. *Ontogeny* des-

cribes the changes in the *protocorallite* (first corallite of the colony) during its development, whereas *hystero-ontogeny* is related to the changes in the offset. Various types of blastogeny are known to occur in Palaeozoic corals and the terms associated with these types are in need of some redefinition, especially since many have been differently interpreted in past papers. A later section of this study is devoted to a discussion of various

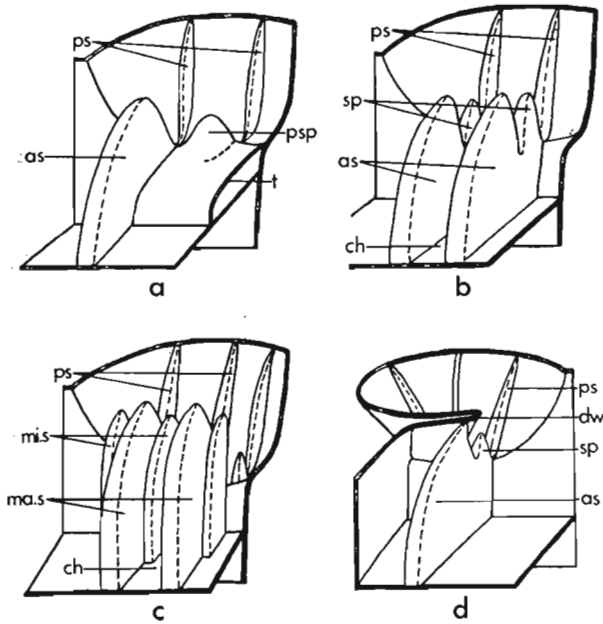

Fig. 1. Schematic reconstruction of characters which may appear in the region of increase during blastogeny. *as* = axial part of septum; *ch* = channel; *dw* = dividing wall; *ma.s* = major septum; *mi.s* = minor septum or newly inserted septum; *ps* = peripheral end of septum; *psp* = pseudo-septal pinnacle; *sp* = septal pinnacle; *t* = tabular element in region between offset and parent. *a* — weakly developed partition of pseudo-septal pinnacles and with parent septa divided into axial and peripheral parts; *b* — weakly developed partition consisting of septal pinnacles with intervening channels; *c* — solid partition with septal pinnacles of major, minor and/or newly inserted septa; *d* — dividing wall constructed from one side of lateral contact between offset and parent corallite.

aspects of these types of blastogeny. Their general character are illustrated in text-figs 2 and 3.

Lateral increase (text-figs 2: 1, 3: 1) involves the offset being related to a single recognizable parent corallite and undergoing its early development near the periphery of the parent. Most commonly few if any horizontal or vertical elements (septa, dissepiments and tabulae) from the parent corallite are permanently incorporated into the offset. Usually only one or less commonly two or three offsets develop from a single parent at one time.

Axial increase (text-figs 2: 3, 3: 3) is characterized by the entire parent corallite being divided into offsets by the modification of some of the pa-

rent septa at the beginning of increase into walls which divide the offsets through the axis of the parent. Pre-existing vertical and horizontal elements of the parent are permanently incorporated into the offset.

Peripheral increase (text-figs 2: 2, 3: 2) is invariably parricidal in nature since at least the central part of the parent corallite, and with it the parent polyp, ceases to develop. A number of offsets, commonly between four and eight, are developed around the shoulder of the calice and these offsets inherit the vertical and horizontal elements of the parent corallite in the region which they occupy. New walls are secreted enclosing the inner sides of the offsets.

Three other types of blastogeny have been cited in past literature. *Coenenchymal increase* has been suitably discussed by Oliver (1968). For reasons discussed below, we do not consider *syringoporoidal increase* and *inter-mural increase* to occur in Palaeozoic corals; these terms should be discarded.

Inherited septa are septa originally in the parent corallite which are inherited by the offset. In lateral increase, any inherited septa are mainly only the peripheral ends and usually these are eventually suppressed (disappear). During the early stages of development in lateral increase, a few *septal pinnacles* or *pseudo-septal pinnacles* (text-figs 1a,b) are commonly visible as semi-circular or elongate features in cross section which are arranged in a line between the two corallites. These are new terms, the first of which describes the upper tips of septa which are disunited from parent septa. Pseudo-septal pinnacles, while resembling septal pinnacles, differ in being constructed of sclerenchyme as pillars on the upper surface of a tabula; they have no connection with pre-existing parent septa, although they may appear between them. Lying between these pinnacles and also the peripheral ends of septa are openings between the two corallites which we term *channels* (text-fig. 1b; Pl XV, fig. 4). Eventually the channels and pinnacles are lost when the wall separating offset from parent is completely constructed.

The offset is bounded by the peripheral wall on its outer side (relative to the axis of the parent) and closed from the parent corallite by one of two types of walls: 1) A *partition* is formed by some combination of the thickened ends of septa, septal and/or pseudo-septal pinnacles, sclerenchyme and horizontal skeletal elements. Sometimes channels cutting the partition are visible but most commonly this wall is solidly constructed. It is often developed during lateral increase, such as the example illustrated of *Lithostrotion* (pl. XV, fig. 4), and as is discussed below it is a temporary structure in fasciculate species and some cerioid species, and a permanent wall in other cerioid species; 2) a *dividing wall* is the other type of wall separating offset from parent corallite. It consists of two layers separated by a central epitheca (pl. XV fig. 1) and is jointly formed by offset and

parent polyps. Almost invariably it is developed progressively from one or less commonly both sides of the lateral contact between the two corallites; typical examples of this are shown by blastogeny in *Favistina* and *Palaeophyllum* described later in this study. In some cerioid species and probably in all asteroid, thamnasteroid and aphroid species the dividing wall is not developed. Interpretation of the manner of construction of the two types of walls is discussed below.

The hystero-ontogeny of the offset can usually be divided into a number of stages of development. We consider the following criteria to be most convenient: 1) *Hystero-brephic stage* (which is approximately equal to the brephic stage of protocorallite ontogeny) is that stage which commences with the initial modification of the parent corallite at the start of blastogeny. This stage normally includes the insertion of at least some of the primary septa; 2) the *hystero-aneic stage* (which is approximately equal to the early aneic stage of the protocorallite) begins with the appearance of the first metaseptum. However, as a result of irregularities in septal insertion and the somewhat oblique angle commonly between the serial sections and the direction of growth of the offset, it is sometimes convenient to take this stage as beginning after the appearance of the earliest metasepta. Many major septa and sometimes also minor septa are inserted during the hystero-aneic stage and commonly this stage includes completion of the partition or dividing wall between offset and parent corallite; 3) the next stage of development is the *late aneic stage* which is taken to start when the offset possesses all or nearly all the characters of the *ephebic (adult) stage* except that it has smaller dimensions and fewer septa.

These stages are difficult to apply to blastogeny other than lateral increase. However, with lateral increase overwhelmingly the most common type of increase in rugose and tabulate corals, the terms are widely useful. Many offsets are probably nearly identical during the hystero-aneic stage, and possibly also the latter part of the hystero-brephic stage, to their protocorallites at equivalent stages of development.

SOME CHARACTERS AND IMPLICATIONS OF BLASTOGENY

Protocorallites are very rarely preserved intact in colonies and the ontogeny of only three species has been studied. These are the Middle Devonian *Hexagonaria anna* (Whitfield) from Michigan, studied by Stumm (1967) and Jull (1973), the Upper Givetian *Phillipsastrea hennahi* (Lonsdale) and *Hexagonaria philomena* Gliński from Nakhichevanska USSR (near the Iranian border) examined by Ulitina (1973, 1974). Likewise there are almost no detailed studies of increase in tabulate corals and almost all our knowledge of blastogeny in Palaeozoic corals comes from offsets of rugosan species.

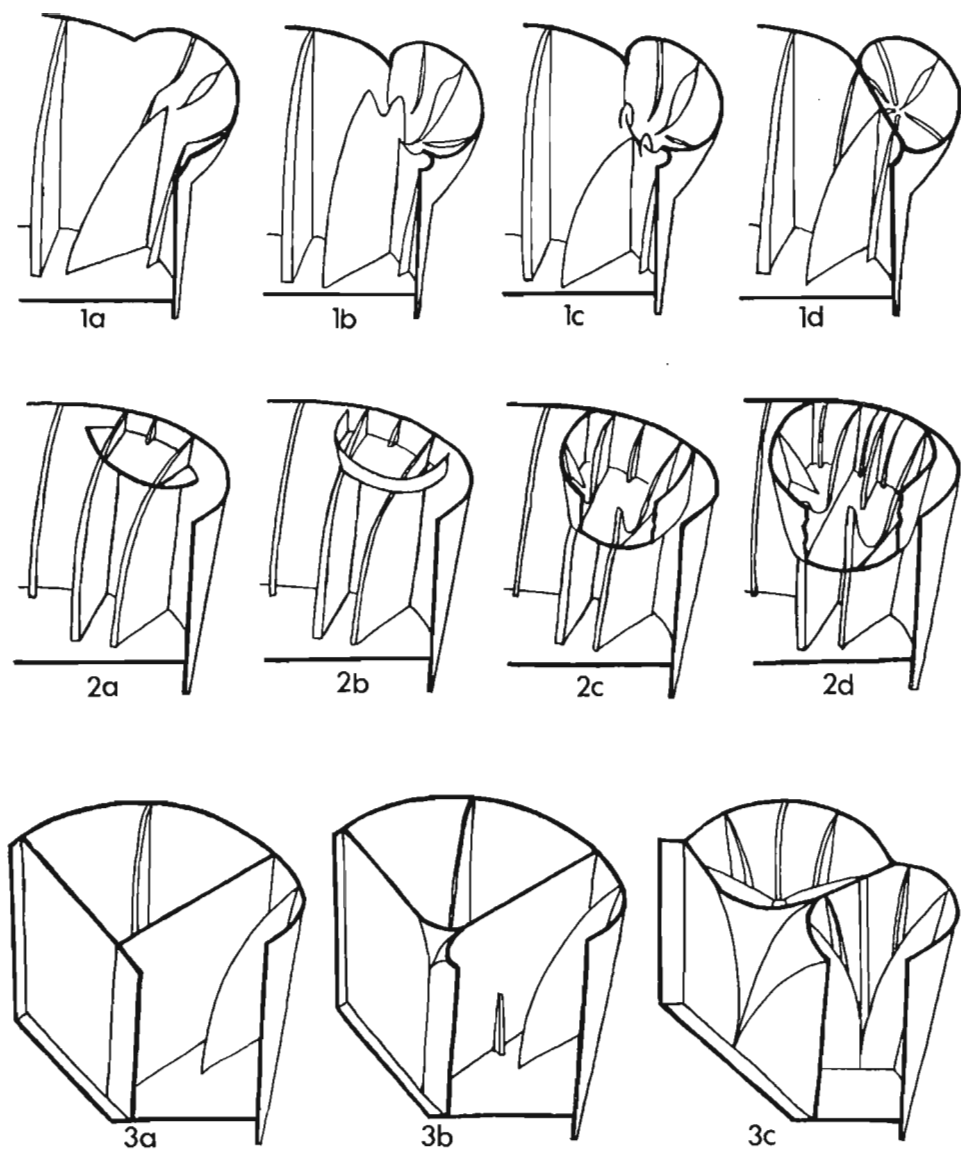

Fig. 2. Schematic reconstructions of lateral, peripheral and axial increase. 1a—d—lateral increase, in which peripheral structural elements of the parent corallite may or may not be permanently incorporated into the offset; a—early part of hystero-brephic stage; b—hystero-brephic stage with septal pinnacles developed; c—hystero-brephic stage with pseudo-septal pinnacles developed; d—hystero-neanic stage, with offset divided from the parent by a dividing wall. 2a—d—peripheral increase, in which structural elements of the parent are incorporated into the offset; a—hystero-brephic stage, showing here a tabula at the base of the region of increase; b—hystero-brephic stage, with dividing wall separating offset from parent corallite; c—hystero-neanic stage with some new septa inserted; d—hystero-neanic or late neanic stage. 3a—c—axial increase, with all structural elements of the parent corallite incorporated into the offsets. a—positions of some septa before the start of blastogeny; b—four long septa become modified into dividing walls; c—offsets begin to separate, and new septa are inserted including the characteristic four long septa forming a cross through the centre of each offset.

Lateral increase

Except for a very few species, rugose and tabulate corals typically construct their colonies by this type of increase. The general sequence of events characteristic of almost all examples in rugose corals studied to date is as follows:

At the beginning of increase the parent septa withdraw from the zone of increase, sometimes leaving behind their peripheral ends and/or septal pinnacles. Horizontal skeletal elements are reduced or disappear and scler-

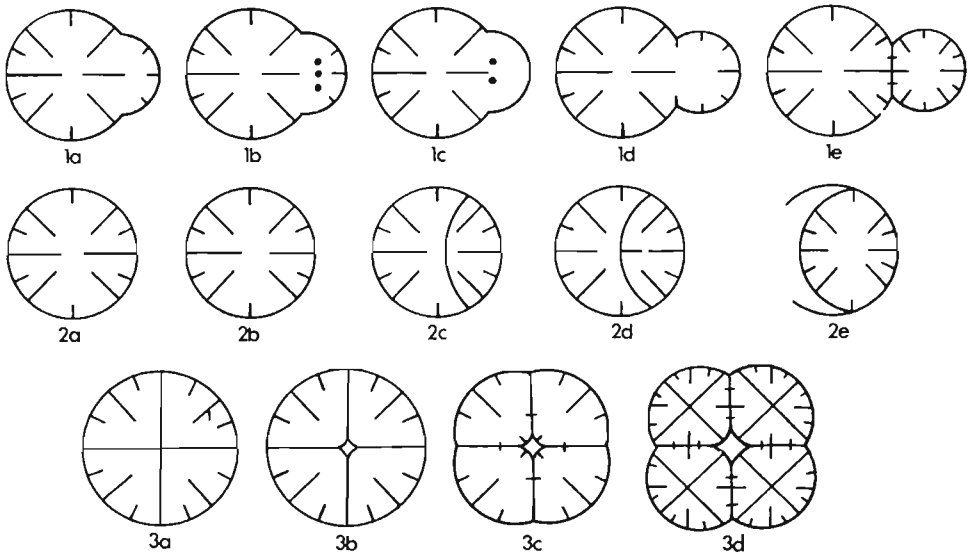

Fig. 3. Schematic two-dimensional reconstructions of lateral, peripheral and axial increase. 1a—e—lateral increase; a—c—hystero-brephic stage, with septal pinnacles (1b) or pseudo-septal pinnacles (1c) developed; d— one type of hystero-neanic stage; e—late neanic stage. 2a—e—peripheral increase; a—prior to the start of blastogeny; b—c—hystero-brephic stage with first basal element built (2b), and offset divided from parent (2c); d—hystero-neanic stage, with insertion on dividing wall; e—near the beginning of the late neanic stage. 3a—d—Axial increase; a—prior to the start of blastogeny; b—four long septa begin to separate at corallite axis and become converted into dividing walls; c—hystero-neanic stage, with new septa inserted on the dividing walls; d—late neanic stage, with four long septa united at axis in each offset.

renchyme is commonly deposited in the zone adjacent to the wall. In fasciulate species the peripheral wall is progressively extended outwards during distal growth. A partition which is sometimes cut by channels, or a dividing wall which may or may not be preceded by the development of a partition, is more or less completely formed in the region between offset and parent at an early stage of increase. We consider the gastrovascular cavities of the two polyps to be connected above the partition when offset and parent corallites are separated by this type of wall.

Since offsets usually develop at some angle to the direction of distal growth of the parent, almost all serial sections of offset development in studies to date are somewhat oblique to the offset, at least during its early development. This is reflected in illustrations which show an apparent acceleration of septal insertion in the outer parts of the offset (relative to the parent). In most species in which the plane of the counter — cardinal septa in offset was determined, this plane points approximately towards the axis of the parent. The cardinal septum can be located either on the peripheral wall, or as in the case of the species studied herein, on the wall separating offset from parent. Septal insertion in most rugosans studied is imperfectly in four fossulae. Certainly the patterns of septal insertion are somewhat distorted by the oblique angle of serial sections. Even allowing for this, the imperfectly ordered pattern of septal insertion of the rugosan plan appears to be largely the result of the genetic character of the offsets; offsets probably reflect the pattern of insertion in the protocorallite in most cases. In one species, *Hexagonaria anna*, a rugosan pattern is totally lacking in both protocorallite and offset and insertion resembles that which occurs in the Middle Ordovician tabulate coral *Foerstephyllum halli* (Nicholson) (Jull, in press).

Amongst species showing some degree of rugosan pattern of insertion, counter-lateral septa are usually not distinctive as primary septa. Normally only the cardinal, counter and two alar septa would appear to be primary septa in colonial species. However, counter-lateral septa are prominent during lateral increase in some of the species studied in this paper, and Fedorowski & Gorianov (1973) illustrate peripheral increase in the Llandoveryan *Entelophyllum losseni* (Dybowski) which may have six primary septa. Further investigation of the counter-lateral septa is necessary in colonial and also solitary rugose corals in order to understand the significance of these septa.

Owing to the mechanics of construction of the offset skeleton and oblique angles of observation, metasepta often appear before all primary septa are inserted (excluding *E. losseni* cited above and some examples studied herein). Sometimes metasepta appear as early as simultaneously with or shortly after the first primary septum is formed. Insertion is rapid and within the space of 1 to 4 mm of distal growth, many of the septa are inserted and the offset bears the characteristics of a small adult corallite. With the exception of situations such as the late appearance of an axial structure, most of the valuable information associated with blastogeny occurs within the first 1 to 4 mm of distal growth.

In spite of the great variation recorded in lateral increase in species ranging from Ordovician to Permian age, we have not observed any basic differences which suggest separation of this type of increase into a variety of types. Even allowing for the other types of increase, the degree of fundamental variation in blastogeny in Palaeozoic corals is remarkably limited.

in comparison with the post-Palaeozoic forms. Later remarks in this paper dwell on our interpretation of the relationship of the soft tissue with skeletal development during lateral increase.

Axial increase

This is a rather specialized type of blastogeny which, in our opinion, is known only in the Silurian *Stauria* Edwards & Haime and *Acervularia* Schweigger. It was first noted by Koch (1883), and Smith & Ryder (1927) and Ting (1940) described it in *Stauria*. Dobrolyubova (1958) considered axial increase to occur in a specimen of *Lithostrotion junceum junceum* (Fleming) from the Lower Carboniferous of the Russian Platform but this example is of a type of increase which has yet to be described in detail. Axial increase was also reported by Wright (1966) in the Devonian *Melasmaphyllum mullamuddiensis* from New South Wales. This species has a peculiar type of blastogeny which is closely related to axial increase. The walls separating offsets are not formed from pre-existing septa as is typical in *Stauria*, but rather they are new structures developed on the upper surfaces of tabulae and extending peripherally through the axis of the parent to separate the offsets.

It is difficult to draw many interpretations from this type of blastogeny. Partitions are apparently absent and offsets are divided from each other only by dividing walls. We agree with Oliver (1968, p. 21) that this type of blastogeny is probably the parallel to intratentacular budding in scleractinian corals. Very likely it is the only type of blastogeny in Palaeozoic corals which is not the parallel to extratentacular budding.

Peripheral increase

Peripheral increase is recorded in various solitary and colonial corals such as the Silurian *Entelophyllum* and *Kodonophyllum* (Smith & Tremberth, 1929; Oliver, 1963), the Devonian *Heliophyllum* (Wells, 1937), and the Carboniferous *Lithostrotion* (Jull, 1965) and *Spirophyllum* (Fedorowski, 1970). One of us (RKJ) has re-examined the remarkable colonies of *Entelophyllum articulatum* and *Kodonophyllum truncatum* studied by Smith and Tremberth. The former specimen (BM R2095) is a small, low spreading colony measuring 12 cm in diameter and 6 cm in height; corallites are conical and blastogeny seems to involve only peripheral increase with three or four generations of offsets developed from the protocorallite. In the latter colony, which is typical of other small colonies of the species, four generations of peripherally produced offsets are present. Both genera have been interpreted to include solitary and colonial forms. Whereas both lateral and peripheral increase may occur in colonies of *Entelophyllum*, the solitary to weakly colonial *Kodonophyllum* seems to form small fasciculate colonies by only peripheral increase. The Lower Carboniferous *Nemistium* and *Aulina* are two other genera in which a number of consecutive generations of peripherally produced offsets might be formed. In many

other genera, however, only one generation of offsets is typically produced by peripheral increase and usually these offsets do not achieve the size of the parent corallite. We do not know of any observations in which large colonies are constructed by means of numerous successive generations of peripherally produced offsets.

We interpret peripheral increase as being a multiple form of rejuvenescence which may occur regularly but more often appears sporadically in some solitary and colonial corals having the genetic potential for such a type of increase. Quite possibly it is often induced by unfavourable conditions which, in a similar manner to phenomena known in other groups of animals and plants, results in a rapid growth potential by the production of numerous new individuals. These offsets incorporate a large proportion of the skeletal elements and probably also the soft parts of the parent into their morphology. Regarding the afore-mentioned colony of *E. articulatum*, environmental stimulus is a logical explanation as to why nearly every corallite on the upper surface of the colony almost simultaneously developed about five offsets each; similar mass production of offsets is unknown in lateral increase.

Blastogeny somewhat like peripheral increase occurs in the Upper Ordovician *Fletcheria tubifera* Edwards & Haime. Stasińska (1967) illustrated good examples of this type of increase, showing clusters of offsets with complete walls enclosed by the wall of the parent corallite. Detailed study of this type of increase may show it to be different to any type discussed in the present paper.

Coenenchymal increase

Lindstrom (1899) and Oliver (1968) discuss this type of increase, with the latter author noting that it occurs within the common tissue (coenosarc) of the colony. We have nothing further to add to their discussions.

Syringoporoidal increase

As noted by Oliver (1968), who re-illustrated Koch's (1883) diagram, there is no true example of syringoporoidal increase in the literature; the identifications of such a type by Rózkowska (1960) and Pickett (1967) are in error. We have observed lateral increase in *Syringopora*, and Nowiński (in press) has studied this type of increase in the genus. It seems improbable that an offset will develop on the connecting tubule between neighbouring corallites, as first suggested by Koch (1883), and we believe that the term should be dropped.

Intermural increase

Most authors agree that intermural increase, which involves the offset developing between the wall of neighbouring corallites and lacking any connection with them, is an improbable circumstance. Most recently, Schouppé and Oekentorp (1974, p. 89) have criticized this term. The closest

examples of this type of increase are those illustrated by Dobrolyubova (1958, text-fig. 14; Pl. 9, fig. 1) and Jull (1967, text-fig. 2). We consider these to be examples of offsets developed by common tissue at the walls of neighbouring corallites, a situation similar to the concept of intermural increase but not fundamentally the same.

Oliver (1968) has noted that the term intermural increase is sometimes used as merely a convenient alternative for lateral increase in massive species, an unfortunate circumstance in our opinion. Even in species of simple genera with small corallites in which superficial examination might suggest that intermural increase occurs, detailed study has shown that increase is actually lateral in nature. For instance Nowiński (in press) has observed lateral increase in Carboniferous favositids from Poland and one of us (RKJ) has seen it in unpublished examples from Silurian and Devonian rocks in eastern North America.

We believe that the use of the term "intermural increase" should be abandoned. Oliver (1968) suggested that blastogeny analogous to intermural increase might exist in species lacking intercorallite walls. Detailed studies have yet to be made of blastogeny in these types of coralla, but even if situations are reported in which the offset cannot be related to a single parent (a probable circumstance) the term "intermural increase" should be not applied to them.

OBSERVATIONS ON WALL STRUCTURE

Examination using the scanning electron microscope was made of various types of walls (peripheral, intercorallite and dividing walls) in specimens of *Palaeophyllum* cf. *vaurealensis* Twenhofel, *P. vaurealensis* Twenhofel, 1928 *sensu* Bolton, 1972, and *Favistina stellata* (Hall). A selection of fasciculate and cerioid species of *Lithostrotion*, involving *L. martini* Edwards & Haime, *L. pauciradiale* (McCoy), *L. "irregulare"* Phillips (from Ashfell, Northumberland), *L. flemingi* (McCoy) and *L. cf. decipiens* (McCoy) was also examined. An earlier study (Sorauf, 1971) also contains some observations on wall structure in rugose corals using the scanning electron microscope.

The three main elements composing the walls, namely septa, interseptal fibres, and epitheca, are each composed of differently shaped crystals. Septa are deeply embedded in the wall and in all samples examined they are composed of rather irregularly shaped crystals with their long axes oriented parallel to the length of the septum (pl. XIV, fig. 1b; Pl. XV, fig. 1b). These septa are presumably of the fibro-normal type but the ideal arrangement of fibres fanning out from a midline is usually not present; it is doubtful that this is caused solely by recrystallization. The contact between the septa and the elongate crystals composing the wall is not sharp and in some cases short septa are mainly manifest as drawn out wall fibres

(pl. XIV, fig. 2a). Tertiary septa in a specimen of *Palaeophyllum* (pl. XIV, figs 1a—c) are similar to neighbouring minor septa in length and in having a somewhat distinctive array of septal crystals totally buried by the elongate crystals characteristic of the wall fibres.

The nature of the epitheca was examined with particular interest. The sides of corallites free of contact with neighbouring corallites and lacking any abrasion have an epitheca composed of a single row of sub-rectangular crystals (pl. XIV, fig. 1c). The epitheca was also investigated in intercorallite walls of fasciculate species of *Palaeophyllum* and *Lithostrotion* where corallites happen to be in contact with one another, and in cerioid species of *Favistina* and *Lithostrotion*. Although it was sometimes difficult to recognize, the epitheca was observed in all colonies examined. Both single rows (pl. XIV, figs 2a—b) and double rows (pl. XV, fig. 3) of subrectangular epithecal crystals were observed, with the former type more common in the specimens examined. We are uncertain at this stage of the effect of recrystallization on wall structures, and interpretation of the nature of the epitheca should await the accumulation of further data.

An epitheca is visible in the dividing wall of offsets of *Palaeophyllum* (pl. XV, fig. 1b). In the example illustrated, the epitheca terminates at about the position of the tip of the arrow. The illustration of a partly developed dividing wall in *Favistina* (pl. XV, figs 2a—b) might show an epitheca (indicated by an arrow) but this is uncertain. However, an epitheca is surely absent in the partition of *Lithostrotion irregulare* (pl. XV, fig. 4).

POLYPOID RELATIONSHIPS DURING BLASTOGENY

Coates and Oliver (1973) have discussed in some detail their interpretation of colony form and polypoid relationships in fossil and living corals. The following observations substantiate their opinion in large part with regard to Palaeozoic corals.

As earlier discussed, we recognize two types of wall structures during blastogeny, namely the partition and dividing wall. These observations were initiated in earlier works (Fedorowski, 1965; Jull 1965) in which we independently arrived at essentially the same conclusions. Fedorowski (1965, figs 59—61) illustrated the two types of walls. We now believe that these walls and their associated structures suggest strong evidence regarding polypoid relationships between various types of colonies.

Fasciculate colonies

In lateral increase in fasciculate species a partition which in some cases is broken by channels is developed. The degree of development varies considerably. At one extreme, wide channels and little development of a solid partition exists, such as the Lower Permian *Tschussowskenia minor* Fedorowski (1965, fig. 20) and the Upper Devonian *Sudetia lateseptata* Rózkow-

ska (1960, figs 33—35). At the other extreme and rather more typical are the examples in which the partition is a solid structure such as in the Lower Carboniferous *Lithostrotion montoense* Jull (1965, text-fig. 2: 2a—m).

However solidly constructed, the partition is invariably a temporary structure in fasciculate species. Normally it disappears when the offset becomes separate from the parent and the dividing wall is progressively developed from both sides along the trace of the partition. In the case of the offset not separating from the parent, as in crowded fasciculate colonies or cateniform arrangements (pl. VIII, figs 3a, 4a), the dividing wall almost always develops from one side only; there is no fundamental difference in these circumstances as was suggested by Jull (1965, p. 207). It should be noted, however, that in some species there is little development of a partition prior to the appearance of the dividing wall.

There is no question, of course, that polyps are separated from one another in fasciculate species, excluding the circumstance of connecting tubules in syringoporoid species. There might be some question, however, as to when separation occurs during blastogeny. We believe this progressively occurs at the stage when the dividing wall, or epitheca within the dividing wall, is developed between the offset and parent. While the partition exists, a sheet of basal ectodermal tissue exists continuously between parent and offset. Evidence suggesting this are:

1. The partition is sometimes only partly solid.
2. Septa may extend continuously through the partition from the parent to the offset.
3. Any sclerenchyme present in the partition is not divided bilaterally between the parent and offset, and an epitheca is absent.
4. Horizontal structures are visible across the zone of the incomplete partition in some cases.

All of these observations are visible in both transverse and longitudinal sections. A continuous sheet of ectoderm extending over the ridge of the partition secretes this structure. A bilaterally symmetrical dividing wall, formed by polyp walls in apposition, is developed by the splitting of the ectoderm. Perhaps simultaneously the entire young polyp is separated from the parent.

Massive colonies

Coates and Oliver (1973) recognized the possibility of two types of cerioid colonies, namely those which are more or less perfectly packed fasciculate colonies with neighbouring polyps separate from one another, and colonies in which common ectodermal tissue, a coenosarc, extends continuously between corallites. We agree with their opinion, and the following discussion presents some evidence associated with the subject.

Schouppé and Oekentorp (1974), however, reject the possibility of common ectodermal tissue uniting polyps in cerioid colonies as it was sug-

gested by Swann (1941; 1947), and Fedorowski (1965). We agree with these authors but only with regard to packed cerioid colonies, and one of our illustrations (text-fig. 4a) is nearly identical to Schouppé and Oekentorp's fig. 10. Quite possibly cerioid colonies of tabulate corals lack common ectodermal tissue, but these corals lack the astreoid, thamnasteroid and aphroid forms which are quite common in rugose corals. Such advanced colony

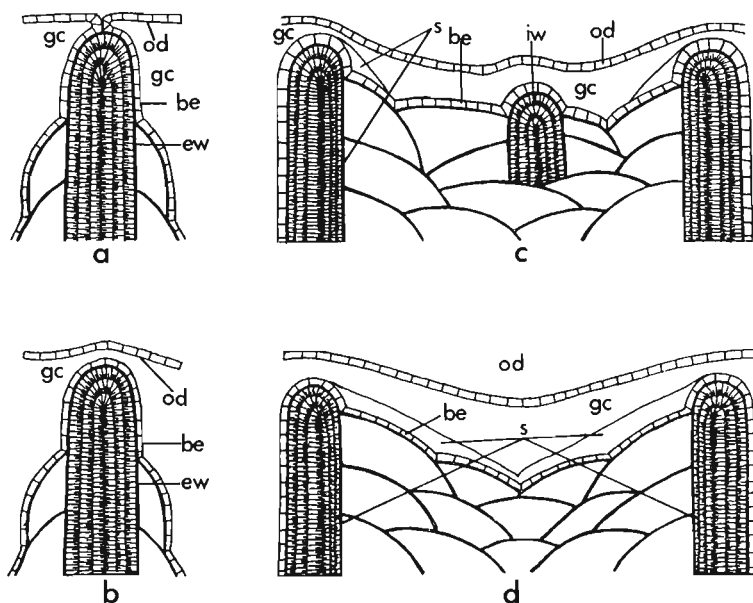

Fig. 4. Relationships between soft parts and skeleton in different types of colonies, with particular attention to the relationship between neighbouring corallites within colonies. *be* = basal ectoderm; *ew* = external wall (dividing wall on fig. a; and partition on fig. b); *iw* = interrupted or discontinuous wall (of partition type); *gc* = gastrovascular cavity; *od* = oral disc; *s* = septum. *a* — dividing wall between corallites in one type of cerioid colony in which gastrovascular cavities of neighbouring polyps are completely separated. Based on an illustration by Schouppé & Oekentorp (1974, text-fig. 10). The dividing wall can also have a central epithelial layer (not shown); *b* — solid partition between corallites in another type of cerioid colony in which gastrovascular cavities of neighbouring polyps are connected above the partition; *c* — cerioid-astreoid type of colony with a discontinuous wall (= partition) and comparatively large dissepiments; *d* — thamnasteroid colony in which septa are united between corallites and gastrovascular cavities are fully connected.

forms would certainly seem to have common ectodermal tissue, as earlier suggested by Coates and Oliver (1973). The close relationship of cerioid colonies to some of these advanced forms might alone suggest that some cerioid species possess common ectodermal tissue.

During lateral increase in cerioid colonies lacking a coenosarc, a dividing wall replaces the partition in the same manner as it does in fasciculate colonies except that the dividing wall is normally developed from one side only. Typical examples are demonstrated by blastogeny in species of *Favistina* described later in this paper, and also in species of *Aphrophyllum*, such as the Lower Carboniferous *A. diphymorphe* Jull (1974, text-fig. 7).

We suggest that the other type of cerioid colony, in which the coenosarc is present, is exemplified by lateral increase in which the partition is not replaced by a dividing wall, but is a permanent structure which is an intercorallite wall which lacks an epitheca. In contrast to partitions during early stages of increase, these walls become more compact and features such as septal invaginations do not extend continuously across the intercorallite wall. The continuity of the intercorallite wall in some species with this type of cerioid corallite is not always perfect; the literature is replete with examples in which intercorallite walls are discontinuous in parts of the colony, especially in late Palaeozoic forms. Although perhaps not all of them represent this type of colony, the absence of an intercorallite wall would seem to represent the failure to precipitate wall fibres by the coenosarc in parts of the corallum. It is only a small step from this situation to the astreoid colony in which a wall is not precipitated by the coenosarc.

It is often difficult to recognize the difference between the two types of intercorallite walls. As earlier discussed, the epitheca is usually a distinct structure when viewed with the scanning electron microscope. Although it will not be present in walls formed by a coenosarc, it is not known at this stage as to whether it is always present in walls formed by two polyps in apposition. The walls are difficult to distinguish from one another using the light microscope (text-fig. 4a, b); septal fibres in walls formed by a coenosarc are somewhat fan-shaped across the wall and this results in the impression of a central dark line similar to an epitheca in transverse section. Detailed study of the blastogeny will determine which type of wall separates corallites in cerioid colonies.

It is quite common in recent Scleractinia for the coenosteum and in some cases gastrovascular cavities and even mesenteries to extend between polyps, even when corallites are separated by a wall. It seems quite reasonable to suggest that a parallel with these corals exists in the Rugosa, although they probably did not achieve the same high levels of integration as manifest in some Scleractinia. The significance of colony integration, a subject discussed by Coates and Oliver (1973), would not only relate to energy distribution within the colony but also to economies related to the secretion of calcium carbonate. In rugosan colony forms ranging from cerioid to cerioid-astreoid, astreoid, thamnasteroid and aphroid, there is a diminished amount of calcium carbonate required per unit volume of skeleton, and colonies are thereby lighter, approaching the situation in many scleractinian corals. This sequence of colony forms, which roughly parallels increasing levels of polypoid integration, can also be interpreted as representing increasing levels of advancement. In this respect, *Ivanovia*, for instance, appears to be more advanced in development than *Aulina* or *Philipsastraea* partly because it has less calcium carbonate per unit volume than the other two genera.

In contrast to cerioid species, there have been few studies of blastogeny

in species lacking intercorallite walls. Fedorowski (1965, figs 55, 57) described and illustrated lateral increase in the Lower Permian species of *Protolonsdaleiastraea* and Ulitina (1973) examined protocorallite ontogeny in the Upper Givetian *Phillipsastraea hennahi* (Lonsdale). Future studies will probably show that whereas lateral increase can be recognized in thamnasteroid and astreoid species, it may be difficult to recognize parent/offset relations in aphroid colonies. Offsets are visible in lonsdaleoid dissepiments of the aphroid Upper Carboniferous *Ivanovia aster* Fomichev (1953, pl. 35, fig. 2). Superficially at least, these offsets cannot be related to any single parent. Future studies will determine as to whether or not increase of a type different to lateral increase exists in aphroid and (less probably) thamnasteroid colonies of *Rugosa*.

Axial and peripheral increase almost certainly involve the development of dividing walls, without partitions present at any stage of blastogeny.

The foregoing remarks are speculative in part and may serve as a guide to future studies of blastogeny in Palaeozoic corals. It does not seem appropriate at this time to suggest new terms for either of the two types of cerioid colonies, or the two types of intercorallite walls; with regard to the latter, we prefer to use the terms "partition" and "dividing wall" only with regard to offset/parent relations during blastogeny, in spite of the fact that both types of walls may eventually bound the adult corallite.

VALUE OF BLASTOGENETIC STUDIES

Study of the blastogeny in fossil corals assists with the solution of taxonomic, phylogenetic and biologic problems. Traditionally, and including most modern examples, coral studies have been, essentially concerned with only the morphology of adult corallites. Only a relatively few papers have included a comprehensive survey of the characters of blastogeny as a routine assessment of the taxonomy of species. The study by Rózkowska (1960) stands as the first example of such a broad survey of a group of corals, and in this study, for instance, she was able to distinguish between *Sudetia* and *Peneckiella* on the characters of blastogeny.

The data available to assess the characters of a species is doubled or even tripled when details of blastogeny are added to the study of adult characters. The following characters seem to be particularly important to an understanding of the corals:

A. The preliminary organization of the zone of increase is a short but important period which almost always occurs within the first 1 mm of distal growth; very closely spaced acetate peel sections are necessary in order to ascertain the details which are commonly diagnostic of the species or even the genus. Some of these are; 1) the insertion of new septa between pre-existing septa to become the first septa of the offset or to replace the

old septa; 2) the dissociation of parent septa into peripheral, medial, and/or axial parts; 3) sclerenchymal thickening and the development of pseudo-septal pinnacles; 4) the disappearance of horizontal elements.

B. During the period of blastogeny involving the latter part of the hystero-brephic stage and all the hystero-neanic stage, the following characters are especially useful; 1) the presence or absence of inherited septa and their position as pinnacles and/or located on the peripheral wall; 2) the character of development of the partition and dividing wall; 3) the character of insertion of septa. This is perhaps the most important of all, especially since it is the best basis for the comparison of the hystero-ontogeny of the offset with the ontogeny of protocorallites and solitary corals.

C. The final stage of development, the late neanic stage, normally reflects the characters of the preceding stage. However some new details, may be evident, such as the appearance of tertiary septa or lonsdaleoid dissepiments, or disappearance of a columella.

To date the blastogeny of only a relatively few groups of corals has been studied. The value of such observations will greatly increase with the future accumulation of detailed data on other groups of corals.

BLASTOGENY IN *FAVISTINA* AND *PALAEOPHYLLUM*

Blastogeny in Rugose corals ranging in age from Silurian to Permian has been studied in the past, but data is lacking on the early representatives of the Order from the Ordovician. Specimens from Upper Ordovician Richmondian rocks in eastern North America of *Favistina* and *Palaeophyllum* were chosen for study for a number of reasons. Primarily, these genera are quite similar to a number of tabulate genera of similar age, and a comparison of their blastogeny with that which is known in *Foerstephyllum* from the Middle Ordovician of eastern North America (Jull, in press) is of interest. Flower (1961) has suggested a lineage with *Foerstephyllum* lying between *Saffordophyllum*, the ancestral form, and *Favistina*. The relationship between the blastogeny in *Favistina* and also *Palaeophyllum*, with that in *Foerstephyllum* should indicate whether or not a linkage might exist here between tabulate and rugose corals. Our specimens are well preserved, providing excellent peel impressions, and septa are strongly developed, offering good possibilities of determining septal insertion reliably.

Description of blastogeny

The only type of increase observed in the colonies studied is lateral in nature, and the offset in all cases is divided from the parent corallite by a dividing wall and not a partition. This means that in this type of cerioid colonies as well as fasciculate colonies polyps lack common coenosarcular tissue. Development of the dividing wall

commences on one side of the zone of increase and is extended across this region, with complete separation of the two corallites taking place when the dividing wall is completely formed. Separation of the two polyps would occur at the same time as development of the dividing wall and epitheca within it.

Favistina stellata (Hall, 1847)

(text-fig. 5, pl. VIII, fig. 1, pl. X, fig. 2, pl. XI, pl. XIII, fig. 1)

All of the colonies studied are cerioid, with their shapes ranging from hemispherical to mushroom shaped; some are concave on the lower surface. Considerable variation in lateral increase is present, even within a single colony or corallite, and although all variations are not illustrated, the significant ones observed are mentioned below.

Hystero-brephic stage. Preliminary to the appearance of the offset, the region of increase is typically occupied by one major septum and two minor septa, and this region is located in the corner of the parent corallite. However, two offsets which are adjacent to one another and developed at the same time were observed to occur outside the corner of the parent. Another exception involved the region of increase being occupied by only a single minor septum.

At the beginning of increase, the major septum in the region becomes discontinuous into axial and peripheral ends. The axial end is shortened and remains in the parent corallite, eventually being extended to become attached to the dividing wall after this structure is secreted. The peripheral part of the major septum, along with the two minor septa, are inherited by the offset. These inherited septa are suppressed at varying times between offsets; it may occur either before or after the dividing wall is formed. In some cases a short inherited septum remains for a brief period of distal growth before being replaced by the new septum in the offset.

The following lists variation which was observed during development of the dividing wall and early insertion of septa:

1. Although the first septum may be inserted well before the dividing wall is completely constructed, most of the offsets observed possess an aseptate period of growth after completion of the dividing wall, as, for example, an offset in BM R602B (pl. X, figs 2*h*—*i*, left-hand offset). This offset was the only one observed in which new septa are first inserted on the dividing wall. Septa appeared in the following sequence in it: alar septum followed by the cardinal septum and the second alar septum. Subsequently, counter and counter-lateral septa appear rapidly on the peripheral wall. Insertion of metasepta during the hystero-neanic stage in this corallite is typical of the species.

2. Two interesting features were noted in offsets of BM R602A (text-fig. 5 B1—4). Firstly, pseudo-septal pinnacles are constructed on the surface of a tabula in the region of increase (text-fig. 5 B2). These pinnacles, in common with others of their type and also septal pinnacles in many other rugose species, probably serves as a support during blastogeny. These pseudo-septal pinnacles become incorporated into the dividing wall. Secondly, a major septum which lies between two offsets becomes modified in the normal way at the beginning of increase, but its axial end becomes attached to the dividing wall of one of the offsets in a different position to its former location.

3. The counter septum is always positioned on the peripheral wall and the cardinal septum is on the dividing wall in this species. The counter septum is almost always the first to be inserted, and in some offsets it appears so early in hystero-ontogeny that it seems to be an inherited septum. Detailed examination shows, however,

that it has only replaced an inherited septum. In an example cited above, the counter septum is among the last of the protosepta to be inserted.

4. Commonly one of the counter-lateral septa is the second septum inserted, although in some offsets (pl. X figs 2a—d), united axial septa, similar to those in many solitary corals, are inserted. In one offset (pl. XI, figs 1d—i) pseudo-axial septa are present by the union of the cardinal septum with one of the counter-laterals. In most of the offsets observed, the cardinal septum is the third septum inserted in the offset, and the first to appear on the dividing wall. Septal insertion is slower on the dividing wall than around other parts of the offset.

Hystero-neanic stage. This stage starts ideally with the insertion of the first metaseptum, but sometimes the first metaseptum precedes the insertion of the protosepta (text-fig. 5 A, upper offset). In this case, the exact position of the commencement of this stage is rather arbitrary. Metasepta are initially inserted as short blunt septa or fine needle-like septa, similar to but rather shorter than the protosepta. Through a series of peel sections, some are observed to be suppressed and reinserted again. Although some suppressed septa do not appear to be reinserted, most septa become permanently established after some period of growth. Many of the major septa meet in the axial region during this stage of development, and in most offsets at least some minor septa can be distinguished within the wall before the end of this stage.

The late neanic stage is characterized by the arrangement of major septa typical of adult corallites, and by the presence of minor septa between almost all the major septa.

Specimen No. BM R36207 pl. XIII, figs 1a—l) has some corallites with a diameter, number of septa and length of minor septa which exceeds typical corallites of *F. stellata* in other colonies examined. Many of its characters of blastogeny are similar to those of this species. Insertion in the offset commences before the dividing wall is completely developed, and the first septum inserted is the counter septum on the peripheral wall. The dividing wall is built simultaneously from both sides of the zone of contact. This is the only example known in which the wall is not built from one side. The cardinal septum is the first to be inserted on the dividing wall, and protosepta are never joined at the axis. Minor septa are first evident flanking the counter septum, and subsequent insertion of minor septa does not alternate with the majors.

Fig. 5. All figures approx. $\times 10$. Numbers below figures are cumulative distances of distal growth in mm. C = cardinal septum; K = counter septum; A = alar septum. A1—11 — lateral increase in two offsets of *Favistina stellata* (Hall), Specimen No. BM R24736A, Saluda Member, Whitewater Formation, Richmondian, Bardstown, Kentucky. Development of offset "a" (lower figures): A1—morphology of the parent corallite with modification of the region of increase of offset "a"; A2—9 — hystero-brephic stage; A2—4 — inherited septa in offset are suppressed and dividing wall is slowly built from one side of the common parent/offset region; A5—6 — insertion of an alar and a counter-lateral septum before completion of the dividing wall; A7 — cardinal and second counter lateral septa are next septa inserted; A8 — first metaseptum is inserted in counter quadrant; A—9 — counter septum and second alar septum are inserted; A10—11 — hystero-neanic stage, with a second metaseptum and two minor septa inserted in counter quadrants. Development of offset "b": This is similar but slower than in offset "a". The very late insertion of the cardinal septum (not shown) is the main difference. B1—4 — a few illustrations of lateral increase in *F. stellata* (Hall), specimen No. MB R602A, same horizon and locality as fig. A. offset "a" (left-hand offset) is established between two major septa (B1), and a pseudo-septal pinnacle is secreted (B2). The appearance of the counter septa is late, similar to that in fig. A. Insertion of the cardinal septum may take place either before (offset "b") or after (offset "a") completion of the dividing wall, but an aseptate stage does not exist.

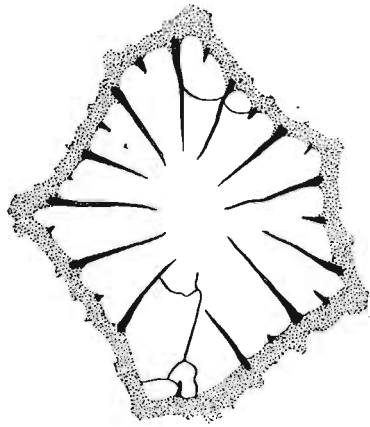

A1 0.0



A2 0.1



A3 0.3



A4 0.45

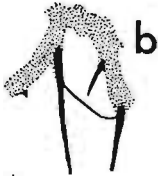
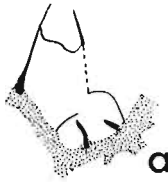

A5 0.6



A6 0.8

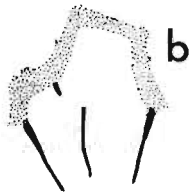

A7 0.9

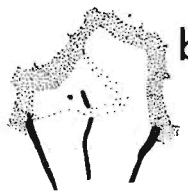

A8 0.95

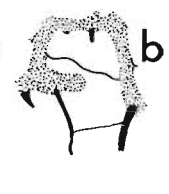

A9 1.1

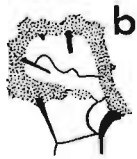
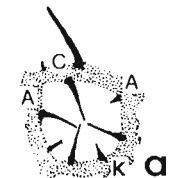

A10 1.25

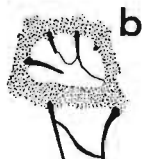

A11 1.35

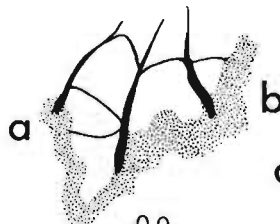

B1 0.0

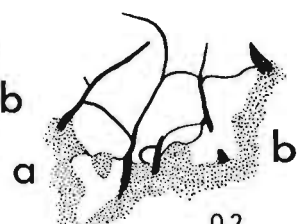

B2 0.2

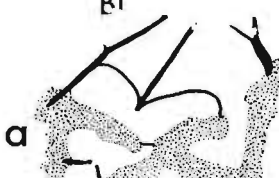
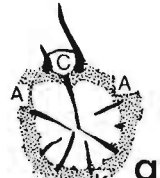

B3 0.4

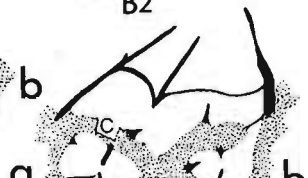

B4 0.6

Favistina calicina (Nicholson, 1875)
(text-fig. 6, pl. VIII, fig. 2, pl. XII, pl. XIII, fig. 2)

Colonies of this species are fasciculate to subcerioid, especially in more distal parts of the colony. Cateniform arrangement of corallites was also observed within some colonies. Offset development is less common and the rate of development of young corallites is slower in the middle and upper parts of the colony than in the astogenetically younger part of the colony.

Hystero-brephic stage. One major septum and two minor septa occupy the zone of increase in the parent corallite. As blastogeny proceeds, these septa are modified in the same way as similar septa in *F. stellata*. Pseudo-septal pinnacles are present in almost every offset observed (text-fig. 6 A1-2, pl. XII, fig. 2a, pl. XIII, figs 2c-d). These pinnacles become incorporated into the dividing wall as it develops from one side of the zone of contact between offset and parent.

Almost all offsets have a short aseptal period of development after the dividing wall is completely formed. The cardinal septum located on the dividing wall is the first septum inserted. Although it may be positioned on the dividing wall opposite to one of the parent septa, there are no connections between offset and parent septa. The counter septum is normally the second septum inserted, but it may appear at the same time as the cardinal septum and form a united axial septum (pl. XII, figs 1c-h, 2c-i). In two of the offsets (pl. XIII, figs 2e-i; text-fig. 6 A6-10, B5-7), the counter septum is inserted very late, after all the protosepta and probably one metaseptum. Alar septa are usually inserted after cardinal and counter septa, and counter lateral septa are inserted next. In one offset (pl. XII figs 1g-i) the first pair of metasepta precede the appearance of the alar septa. The counter septum in this same offset becomes very short (pl. XII, figs 1h-o).

Another offset with variation in septal insertion is shown in text-fig. 6A. Here, the sequence of insertion is as follows; cardinal, first counter-lateral, first and second alar, second counter-lateral, counter and first metaseptum in the cardinal quadrant. The counter septum is the shortest protoseptum until the adult stage.

Hystero-neanic stage. Insertion of metasepta normally begins in the counter quadrants, although exceptions occur quite often; they are inserted one after another. Protosepta during this stage are united at the axis and minor septa were not observed in the walls. Insertion of metasepta is slow and only a few are formed since septa are not numerous in this species.

Fig. 6. All figures approx. $\times 10$. Numbers below figures are cumulative distances of distal growth in mm. C = cardinal septum; K = counter septum; A = alar septum. A1-16 — Lateral increase in *Favistina calicina* (Nicholson), Specimen No. BM R56435A, Upper Member (Meaford), Georgian Bay Formation, Richmondian, Credit River, Ontario. A1-10 — hystero-brephic stage; A1-3 — beginning of blastogeny with a pseudo-septal pinnacle, followed by the dividing wall being formed; A4-5 — aseptate stage after completion of the dividing wall; A6 — insertion of cardinal septum on dividing wall; A7-9 — next protosepta are inserted as follows: first counter-lateral, first alar, second alar; A10 — second counter-lateral septum, counter septum and first metaseptum in cardinal quadrant appear almost simultaneously; A11-15 — hystero-neanic stage, showing metasepta which are inserted, suppressed, and re-inserted again, although protosepta are permanently established; A16 — late neanic stage with metaseptum present in each quadrant. Minor septa are still not visible in the wall. B1-10 — Lateral increase in *F. calicina* (Nicholson), Specimen No. BM R6435B, same horizon and locality as fig. A. For detailed explanation see pl. XIII, figs 2a-n, B1 — morphology of parent corallite showing some pathologic (?) alteration of major and minor septa; B2-8 — hystero-brephic stage; B9-10 — hystero-neanic stage.

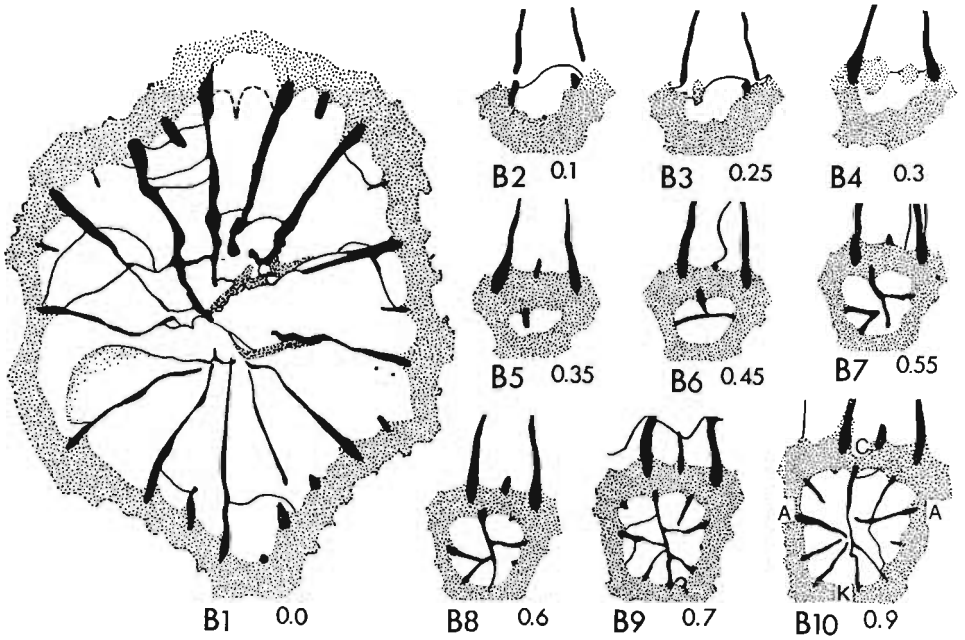
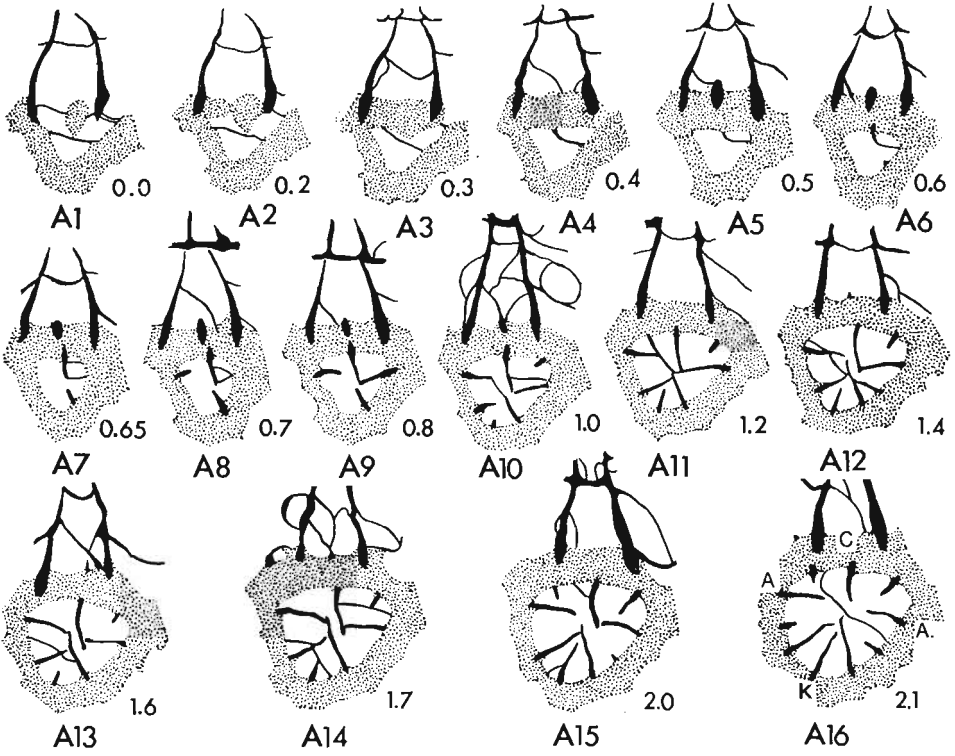

Late neanic stage. Protosepta withdraw from the corallite axis, becoming shorter and separate from one another. Although details of the insertion of minor septa were not established, they were observed to appear during this stage in the wall irregularly but simultaneously between at least a few major septa. It seems that minor septa may appear almost simultaneously in the late neanic stage. They are certainly not inserted alternately with the major septa (cyclic insertion). Weyer (1972) argued that cyclic insertion does not occur in rugose corals. However, it would appear to be imperfectly present in some examples of *Palaeophyllum* described below, and in other species studied in the past.

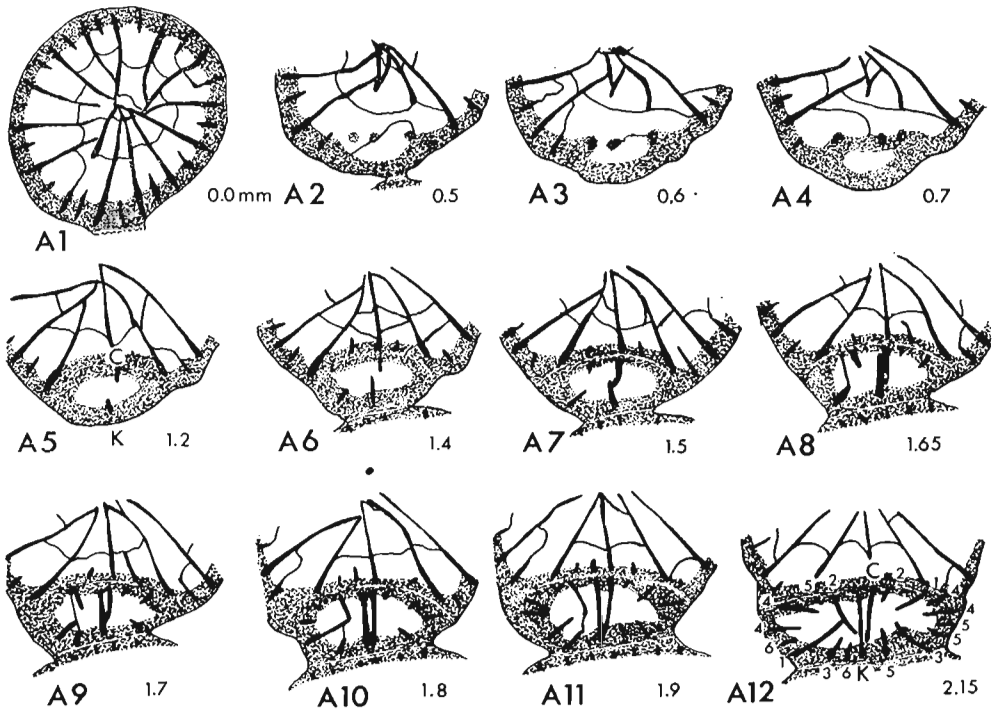

Fig. 7. All figures approx. $\times 10$. Numbers below figures are cumulative distances of distal growth in mm. C = cardinal septum; K = counter septum. A1—12 — lateral increase in *Palaeophyllum* cf. *vaurealensis* Twenhofel, specimen No. GSC 31353, Vaureál Formation, Richmondian, Anticosti Island, Quebec. 1 — morphology of parent corallite, showing one major septum in the region of increase split into axial and peripheral ends; 2—7 — hystero-brephic stage; 2—3 — shortening of axial ends of three major septa and suppression of their peripheral ends together with associated minor septa. Pseudo-septal pinnacles appear and the dividing wall begins to develop from one side of the contact between offset and parent; 4 — rapid completion of dividing wall enclosing an aseptate offset which remains without septa for nearly 0.5 mm of distal growth; 5—7 — insertion of cardinal and counter septa which lengthen to meet, and insertion next of two septa in both quadrants; 8—12 — hystero-neanic stage, showing the offset becoming transversely elongate as a result of intercorallite crowding. Counter and cardinal septa each extend to the opposite wall parallel to one another, and major septa are inserted in all quadrants. Counter-laterals do not become prominently long, and alar septa are inobvious; in A12, septum 1 located right of the cardinal septum and septum 2 or 4 left of the cardinal septum may be alar septa. Minor septa appear in A11—12 flanking the counter septum and between a few other major septa.

Palaeophyllum cf. *vaurealensis* Twenhofel 1928
(text-figs 7, 8, pl. VIII, fig. 3, pl. X, fig. 1)

The following discussion is based on specimen No. GSC 31353. Of the four specimens of *Palaeophyllum* studied herein, this one compares most closely with Twenhofel's (1928) description of *P. vaurealensis*. Unfortunately his description of the species is brief and he illustrated only an external view. Corallites in GSC 31353 have a cateniform arrangement and measure 3 to 3.5 mm in diameter. Some 15 or 16 long major septa, most of which meet in the axial region, and an equal number of short minor septa are present. Tabulae are arched upwards across the axial region; this is the reverse of Twenhofel's observation of tabulae in *P. vaurealensis*. Very likely he misinterpreted the orientation of his specimens.

A newly observed character in GSC 31353 is the presence of very short tertiary septa around parts of many of the corallites; these septa are also present in another specimen (GSC 31352) which is described below, and also in a few species of the Silurian *Acerularia* as noted by Smith and Lang (1931). Such septa are otherwise not recorded in corals older than the Upper Carboniferous. Observations of tertiary septa through a series of peel sections of GSC 31353 show that in a similar manner to minor septa which are commonly of the same length, they often disappear and re-appear. They are not evident during blastogeny until well into the late neanic stage.

Adult corallites in the colony are arranged in chains and almost all are in contact with neighbouring corallites on one, two, or less commonly three sides. Four of the six offsets studied are developed on free sides of parent corallites, and most of their growth occurs external to the normal periphery of the parent. Two other corallites arise on the sides of a parent corallite in contact with neighbouring corallites. Increase in size of the two offsets is accompanied by a pushing aside of both the parent and the respective neighbouring corallite, thereby lengthening the chain. In every example, offsets do not become separated from the parent as is normal in fasciculate colonies, and all are sooner or later in contact with neighbouring corallites, establishing new linkages in the chains. In these respects, astogeny in this specimen is probably more or less representative of other cateniform rugose colonies, and shows some basic differences to that in fasciculate species.

Hystero-brephic stage. Increase commences with thickening of the wall in the zone of increase. From 4 to 6 major and minor septa of the parent are involved in this zone. During blastogeny, these septa are modified in the same way as was described in *F. stellata*. Prior to, and during secretion of the dividing wall, one or a few pseudo-septal pinnacles are usually present in the region between the offsets and parent.

Septal insertion commences in two of the offsets before the dividing wall is completely formed (text-fig. 8) whereas in the other four insertion does not commence until after the wall is completed (text-fig. 7).

Septal insertion is quite variable in the specimen and it is difficult to determine as to whether the cardinal septum is located on the dividing wall or peripheral wall. Because every other specimen of *Palaeophyllum* and *Favistina* studied has shown the cardinal septum to be positioned on the dividing wall and the counter septum on the peripheral wall, this configuration was tentatively chosen for the present specimen, although it could be quite the reverse. The counter septum is the first to be inserted in all offsets, but only in one example (text-fig. 7) is the cardinal septum

the second inserted septum. More typically the septa flanking the counter septum, the counter-lateral septa, are inserted next.

Hystero-aneanic stage. Both alar and cardinal septa, with one exception, appear during this stage of increase after a number of metasepta and even a few minor septa are inserted. The positions of the alar septa are very tentatively indicated in text-figs. 7 and 8 by small arrows on the corallites with numbered septa.

During the early part of this stage the counter septum is lengthened to meet the shorter cardinal septum across the axis. The counter-lateral septa are extended at the same time to become the second longest pair of septa in the offset; in one case, a counter-lateral septum rather than the counter septum is the longest in the offset and meets the cardinal septum (text-fig. 8 B6-8). Other major septa are eventually lengthened so that all are approximately the same length and meet in the axial region. The numbered septa in the offsets illustrated show that insertion does not regularly occur in fossulae. In a general sense, septa near the counter septum are commonly inserted earlier than those near the cardinal septum. Minor septa appear progressively with the majors but insertion of the two types does not alternate between them in a well ordered manner. The first tabulae are evident near the end of this stage.

Late aneanic stage. The beginning of this stage is arbitrarily taken when the offset measures about half the diameter of adult corallites and possesses some 20 to 24 septa. Approximately 2 mm of distal growth has occurred since the beginning of blastogeny.

Most major septa meet in the axial region at the beginning of this stage, but as development continues they withdraw somewhat and do not meet as solidly. In some offsets, major septa may become grouped to form a type of aulos around the cardinal or nearby septum; this feature does not persist into the adult stage. Tertiary septa begin to make their appearance sometime during this stage. In one offset, the earliest tertiary septa are evident after nearly 4 mm of distal growth. Subsequent development involves only an increase in corallite diameter and number of septa.

Fig. 8. All figures approx. $\times 10$. Numbers below figures are cumulative distances of distal growth in mm. C = cardinal septum; K = counter septum; Arrows on figs A12, A18, and B10 point to possible positions of the alar septa. A1-18 — lateral increase in *Palaeophyllum* cf. *vaurealensis* Twenhofel, specimen No. GSC 31353, Vauréal Formation, Richmondian, Anticosti Island, Quebec. Same offset as illustrate in pl. X, fig. 1. 1 — parent corallite with thickened wall in zone of increase; 2-6 — hystero-brephic stage, with pseudo-septal pinnacles between the ends of three parent major septa which subsequently withdraw axially. Insertion of the counter septum in A4 and of a metaseptum in A5; 7-16 — hystero-aneanic stage; 7-11 — progressive development to completion of dividing wall, lengthening of counter septum to meet the dividing wall (when cardinal septum is formed) in A11, and insertion respectively through this series of a metaseptum, two counter-lateral septa, minor septa flanking the counter septum, and minor septa on the cardinal sides of each counter-lateral septum; 12-16 — insertion of alar septa (see arrows in A12) followed by other major and minor septa on either side of each alar septum; 17-18 — late aneanic stage, showing the first tabula in A17, and some tertiary septa and aulos-like structure in A18. This aulos-like arrangement of septa does not persist into the ephebic stage. B1-10 — lateral increase in the same specimen. 1-4 — hystero-brephic stage, showing highly thickened wall, splitting of parent septa into axial and peripheral ends, and insertion of counter septum in B3 and counter-lateral septa in B4; 5-9 — hystero-aneanic stage, showing typical dividing wall development, with one pseudo-septal pinnacle. A counter-lateral septum becomes the longest septum, reaching nearly across the offset, and the cardinal septum appears in B7, followed some septa including an alar septum in B8, with minor septa irregularly alternating with major septa. Insertion is slow on the side of the offset last open to the parent; 10 — late aneanic stage.

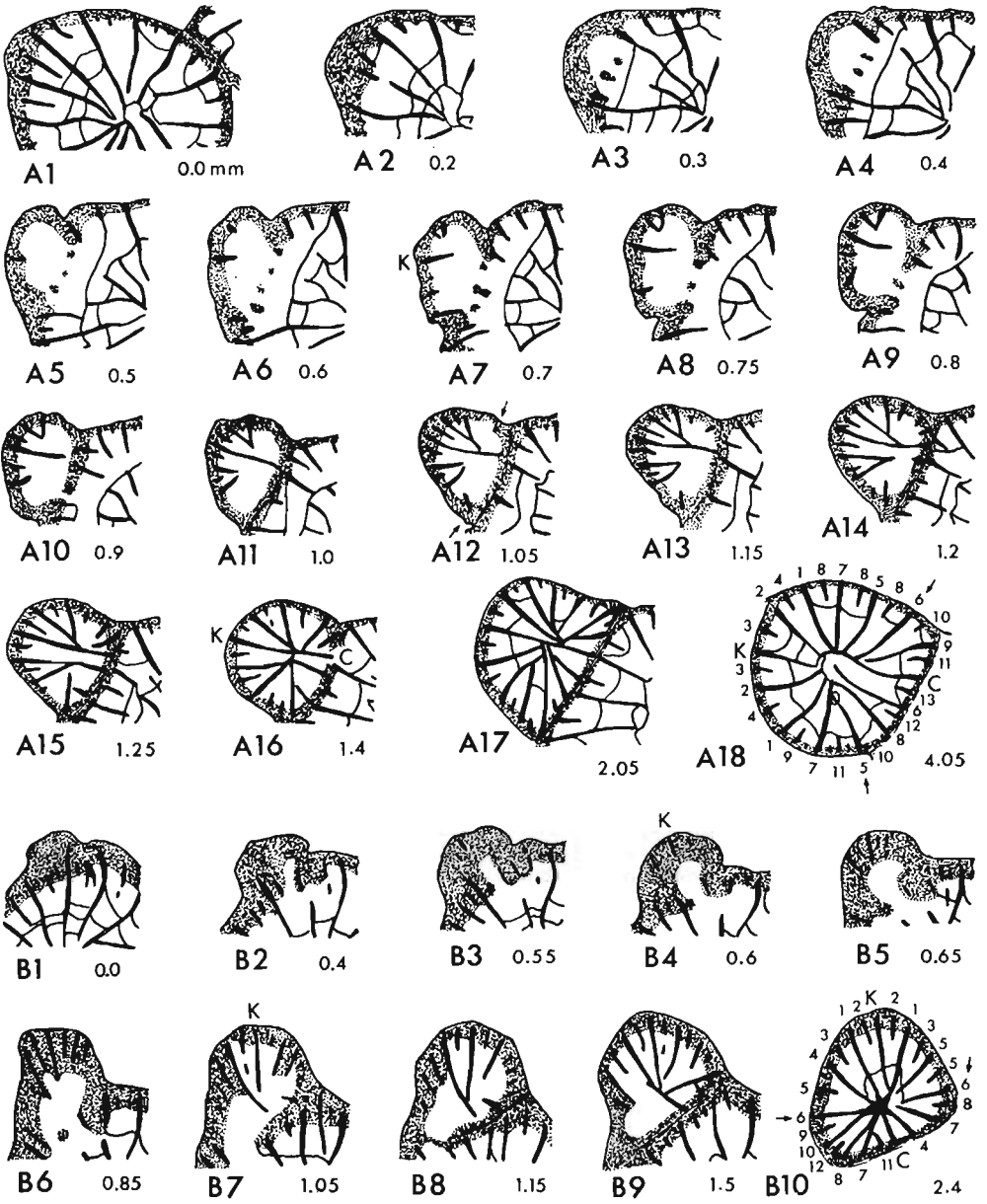

Palaeophyllum vaurealensis Twenhofel, 1928 *sensu* Bolton, 1972
(text-fig. 9, pl. VIII, fig. 4, pl. IX, fig. 1)

Specimen No. GSC 31352 is very similar to the sections illustrated by Bolton (1972, pl. 3, fig. 7) of material from the same horizon on Anticosti Island. Corallites of our specimen are arranged in short chains but the cateniform pattern is not as well developed as it is in GSC 31353 nor are corallites as closely spaced. Corallites average 4 to 5 mm in diameter and have 17 to 19 long major septa and a similar number of minor septa. Tertiary septa are also present and these are a little better developed than they are in GSC 31353. The two colonies are quite similar and obviously closely related; future studies may show them to be related as subspecies or even belong to the same species. The two, however, differ somewhat in their details of blastogeny. Four offsets were studied in the specimen.

Hystero-brephic stage. The wall is considerably thickened in the zone of increase at the beginning of blastogeny. This thickening is also present in the dividing wall when it forms. Most commonly three major septa and two minor septa of the parent corallite are involved in the zone of increase. Although their subsequent modification is similar to that in earlier described species, one or two of the peripheral ends may persist in the offset until just about the time of the first insertion of new septa in the offset. These parent septa might appear to be permanently inherited by the offset but careful examination shows that they are replaced by new septa. A tabula is present in the region between offset and parent, and two of the offsets have pseudo-septal pinnacles. Insertion of septa may begin before or after the wall is completely developed. Sections through one offset (text-fig. 9 B) show septal insertion commencing when the zone of increase is still thickly invested with sclerenchyme and well before the start of the dividing wall. This offset is developed laterally from the parent at a higher angle than in the other offsets and probably its distinctiveness is partly due to the relatively high angle between its direction of growth and the plane of the sections.

Fig. 9. All figures approx. $\times 10$. Numbers below figures are cumulative distances of distal growth in mm. C = cardinal septum; K = counter septum; A = alar septum. A1—15 — lateral increase in *P. vaurealensis* Twenhofel, 1928 *sensu* Bolton, 1972, specimen No. GSC 31352, Vauréal Formation, Richmondian, Anticosti Island, Quebec. Same offset as illustrated in pl. IX, fig. 1. 1 — region of increase before the start of blastogeny; 2—8 — hystero-brephic stage, with development of dividing wall and long persistence of the peripheral ends of parent septa in offset, with suppression of the last ones in A7. Cardinal and counter septa are inserted in A7 and they are united in A8 at the same time as insertion of both alar septa, with a metaseptum in a cardinal fossula appearing next; 9—13 — hystero-neanic stage, showing insertion of major and minor septa in the cardinal quadrants, followed by the appearance of prominent counter-laterals and subsequently other major and minor septa irregularly alternating with one another. Most major septa are united in the axial region. 14—15 — late neanic stage, with first tabula visible in A14, and a few tertiary septa in A15 when the offset is nearly at the ephebic stage. B1—7 — lateral increase in the same specimen. The direction of development of this offset from the parent is at a greater angle than in other offsets studied and sections are therefore more oblique than normal; this results in the impression of late development of the cardinal quadrants. 1—2 — hystero-brephic stage, showing highly thickened wall and the appearance of very short septa (counter septum and a counter-lateral septum) in B1 which are lengthened in B2; 3—7 — hystero-neanic stage, showing a tabula and pseudo-septal pinnacles in B3—5, followed by development of the dividing wall. Insertion involves the appearance of the second counter-lateral septum, followed by minor septa flanking the counter septum, other metasepta and finally in B6 insertion of the cardinal septum and both alar septa. Additional major and minor septa appear in B7, with many major septa meeting near the axis.

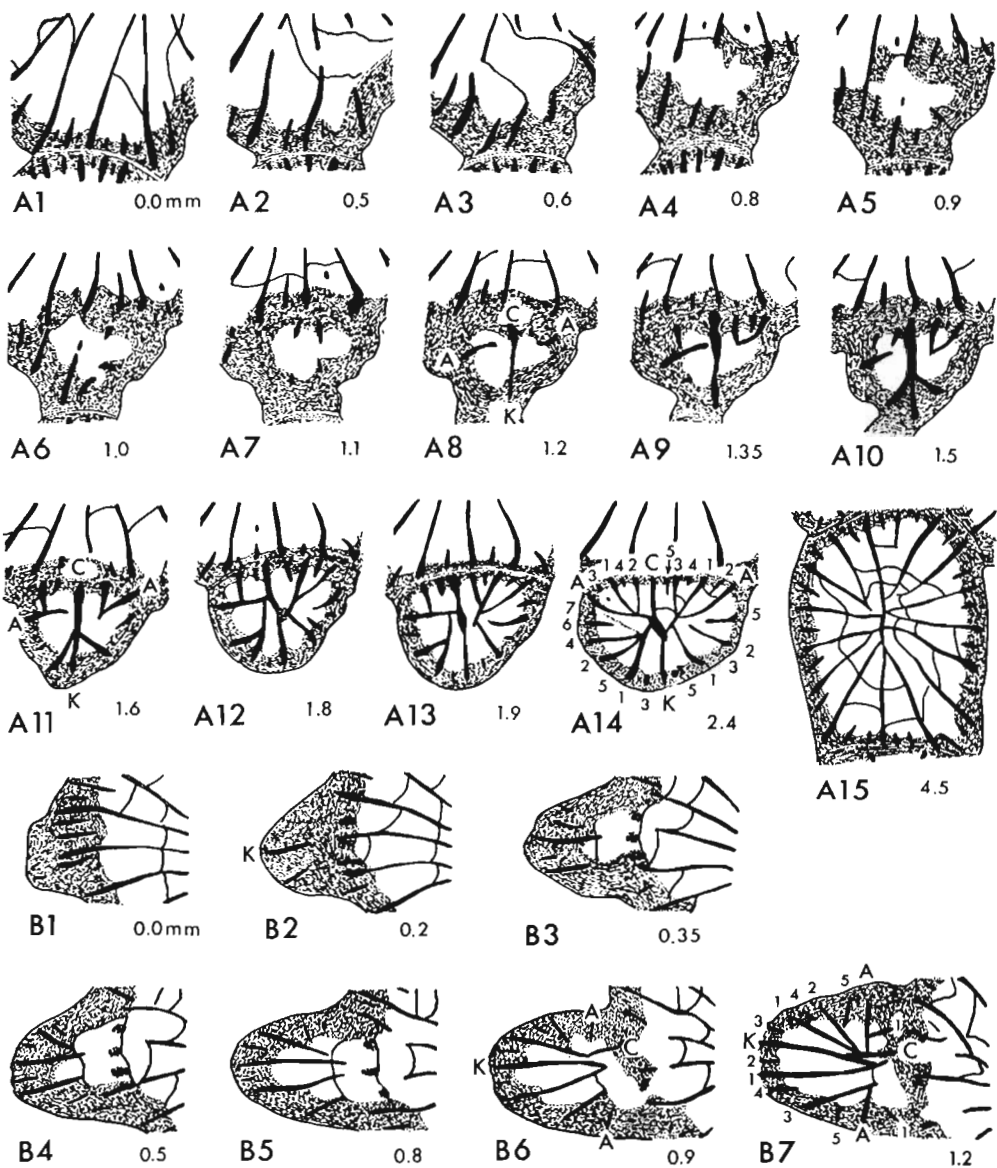

If insertion commences before completion of the dividing wall, the counter septum on the peripheral wall is the first to be formed, followed by the counter-laterals. Alar septa and the cardinal septum appear later, depending on how slow the dividing wall is in forming (or how oblique the sections are to the offset). When the dividing wall is completely formed at the beginning of insertion, however, the cardinal septum on the dividing wall and counter septum opposite to it appear almost at the same time and are quickly united across the axis. Long alar septa are the next to appear.

Hystero-neanic stage. In offsets with a complete dividing wall at the beginning of this stage, insertion is initially more rapid in the cardinal fossulae than the alar fossulae. Counter-cardinal septa remain united through this stage of development and may be dilated. Counter-lateral septa are quite distinctive during the early part of this stage, being long and sometimes leaning against the counter septum; they soon become indistinguishable from the other septa. Insertion in this specimen follows quite a regular pattern in the offsets studied. Most of the metasepta are inserted in a typical rugosan sequence in the four fossulae, and some 6 to 8 major septa are present before the appearance of the first minor septa flanking either the cardinal or counter septum. Subsequent minor septa are inserted rapidly. Tabulae are first evident near the end of this stage or beginning of the next.

Late neanic stage. This stage is taken to begin when minor septa occupy most spaces between the majors. About 2 mm of distal growth of the offset has occurred and all but one or two major septa remain to be inserted. Other than increase in size of the corallite and the addition of a few more major and minor septa, the only notable event during this stage of growth is the appearance of tertiary septa around parts of the corallite. The exact time of their appearance in this stage was not determined.

Palaeophyllum sp.

(text-fig. 10, pl. VIII, figs 5, pl. IX, fig. 2)

Corallites of specimens No. GSC 31354 and 31355 are more tightly packed than those of either the two other specimens of *Palaeophyllum* studied. Colonies approach a cerioid form, although gaps exist between clusters of corallites. Tertiary septa are hardly developed at all; only the occasional slight swelling of the wall might indicate the existence of such septa. With corallites averaging 3.5 to 4 mm in diameter and having 16 to 18 septa of each order, these colonies lie midway between the two previous ones. Tabulae are arched over the axis. Two examples of blastogeny were examined in each specimen (in GSC 31355, sections are spaced at 400 micron intervals) and these show characters different to either of the preceding colonies of the genus examined.

Hystero-brephic stage. One minor septum and either one or two major septa of the parent are involved in the zone of increase. Very little thickening of this zone occurs at the beginning of increase. Pinnacles are absent in the region between offset and parent, but a tabula is present and it is along the line of this tabula that the dividing wall is developed.

Insertion in the offset commences when the dividing wall is nearly complete. The first septum formed is either the cardinal septum or one of the alar septa. The counter septum appears after one or a few metasepta are inserted, and the alar septum which is late in appearing is the one located on the side of the offset last open to the parent corallite.

Hystero-neanic stage. The cardinal and counter septum do not become strongly attached across the axis during this stage and may not meet at all, with the counter

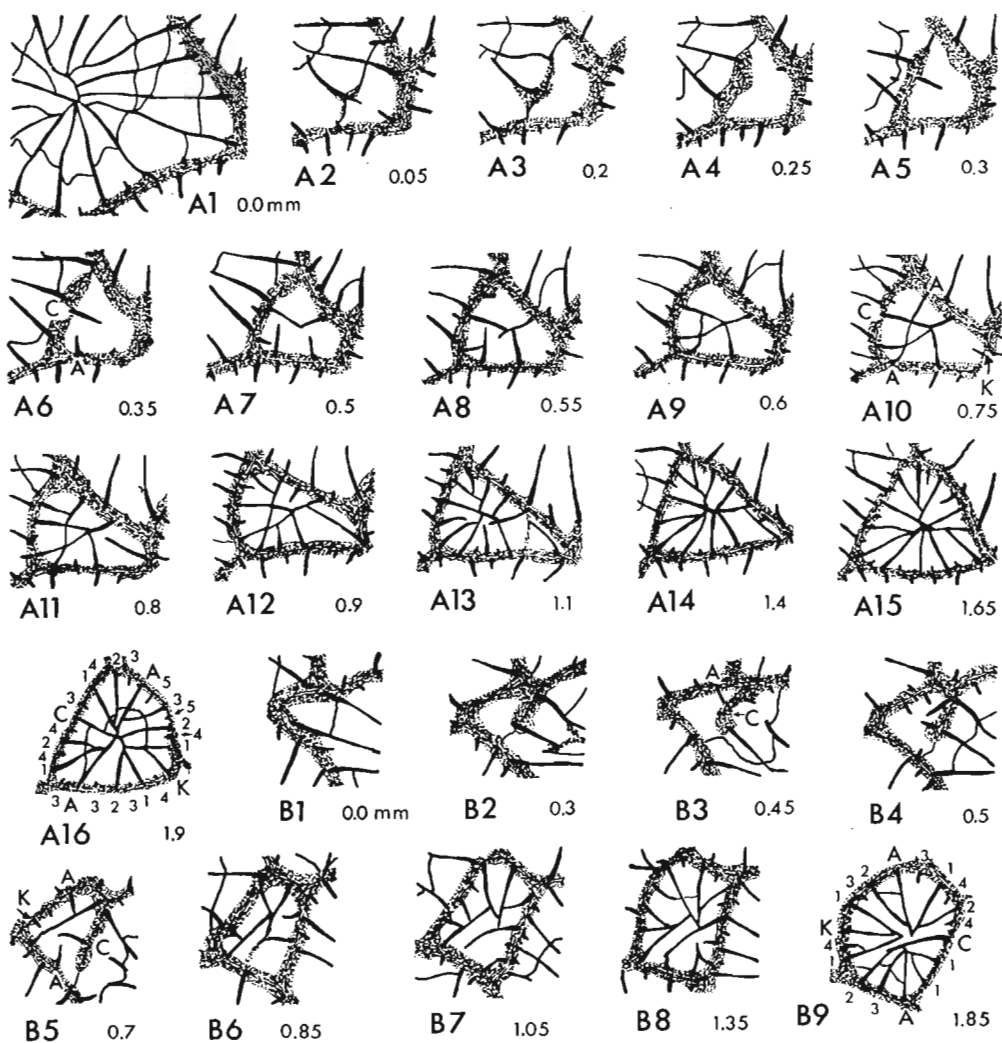

Fig. 10. All figures approx. $\times 10$. Numbers below figures are cumulative distances of distal growth in mm. C = cardinal septum; K = counter septum; A = alar septum. A1-16 — lateral increase in *Palaeophyllum* sp., specimen No. GSC 31354, Vauréal Formation, Richmondian, Anticosti Island, Quebec. Same offset as illustrated in pl. IX, fig. 2. 1 — parent corallite prior to the start of blastogeny; 2-6 — hystero-brephic stage, with development of the dividing wall along the trace of a tabula lying between offset and parent. Peripheral ends of parent septa are suppressed in A4 and the cardinal septum is inserted in A5, followed by an alar septum in A6; 7-14 — hystero-neanic stage, with insertion of both counter-laterals and a metaseptum in A7, followed by the counter septum in A8. The second alar septum appears in A10, and additional insertion of only major septa ensues to A12. The counter septum is lengthened but never unites with the cardinal septum, and the earliest minor septa appear in A13, with more following in A14. Throughout this sequence, septa seem to cross one another, but this is possibly because of tabulae in the corallite; 15-16 — late neanic stage, with minor septa present between almost all majors. B1-9 — lateral increase in the same specimen. 1-3 — hystero-brephic stage, with a similar tabula/dividing wall situation as fig. A. An alar and a short cardinal septum appear in B3; 4-8 — hystero-neanic stage, with insertion of a metaseptum in a cardinal fossula and one counter-lateral septum in B4, followed by the counter and another alar septum in B5. Both counter and alar septa are suppressed in B6, and re-inserted in B7 along with other major septa. A few minor septa are present in B8; 9 — "late neanic stage" with septa somewhat irregularly disposed and with a number of minor septa present.

septum remaining short; in one case this septum is temporarily suppressed. In spite of the late appearance of the counter septum and one of the alar septa, insertion is subregular in fossulae and there is little difficulty in determining the position of protosepta. The counter-laterals are not distinctive septa during development as they are in other species of the genus. Most of the major septa are inserted in an orderly pattern and these are lengthened to meet in the axial region. Minor septa appear rapidly between the majors near the latter part of this stage when about 10 major septa are present. At about this time the first tabula in the offset is visible.

Late neanic stage. This is taken to commence when the corallite has about 12 major septa and nearly the same number of minor septa after 1.5 to 2 mm of distal growth. Remaining development involves only insertion of additional septa and increase in corallite diameter.

Summary of blastogeny in *Favistina* and *Palaeophyllum*

It is clear from the foregoing descriptions that the five species studied have many characters in common during blastogeny. Although fewer parent septa are usually involved in the zone of increase in *Favistina* than in *Palaeophyllum*, modification of these septa during the earliest part of increase is similar in all cases. None of the offsets permanently inherit the peripheral ends of parent septa. The presence in most cases of pseudo-septal pinnacles and the manner of development of the dividing wall is also basically similar in the colonies studied. Furthermore, a partition is not developed in the offsets. The counter-cardinal plane is always oriented approximately towards the axis of the parent and except for one doubtful case (*P. cf. vaurealensis*) the identification of the cardinal septum on the dividing wall and counter septum on the peripheral wall was quite reliably determined; in some of the past studies of blastogeny, the reverse of these positions was established. Another feature not hitherto noted in lateral increase in rugose corals is the prominence of the counter-lateral septa during early septal insertion in most of the colonies; they may well be regarded as protosepta in the two genera. Finally, with the exception of *P. cf. vaurealensis*, and allowing for the often late appearance of some of the protosepta, septal insertion distinctly, if imperfectly, follows the classic pattern in rugose corals.

It may appear that since there are so many characters common to the blastogeny in these morphologically simple genera, there is little to distinguish between them apart from adult characters and colony form. This is not the case. Each possesses a variety of characters during corallite development which distinguish them from the other species. Irrespective of relatively small differences in corallite diameter and septal number between specimens of *Palaeophyllum*, for instance, the differences in the characters of blastogeny would strongly suggest that they are taxonomically separate entities. However, the many common features between the five species studied indicates that they are a closely related group.

There has never been any doubt as to these genera belonging with the

Rugosa and the characters of blastogeny confirm this. There is some question, however, as to the relationship between *Favistina* in particular and some tabulate genera of a similar age and distribution which, apart from having shorter septa, are otherwise very similar to this genus. A comparison between blastogeny in *Foerstephyllum* (Jull, in press) with that in the present specimens shows that resemblances in the adult characters appear to be superficial. The dividing wall in *Foerstephyllum* is formed in quite a different way and septal insertion lacks any rugosan pattern. Not even the position of any of the protosepta could be determined; at least the counter-cardinal plane can be located in *P. cf. vaurealensis*, the species with the most irregular pattern of septal insertion studied herein. One species of *Foerstephyllum*, namely *F. vacuum* Bassler, should be noted however, since the opening stages of septal insertion in a specimen of this species fleetingly shows three long septa (?counter or cardinal, and two alar septa) which are similar to those in *Favistina*. They disappear and a foerstephyllid type of insertion ensues. Although of course there is no question of this species representing an ancestral form of the Rugosa, perhaps a linkage exists through this species between more typical representatives of *Foerstephyllum* (Tabulata) and *Favistina* (Rugosa), as suggested by Flower (1961). Speculation on the subject is tempting but perhaps premature at this stage, especially with the example of a 'foerstephyllid' type of insertion in *Hexagonaria anna* (Jull, 1973), a thoroughly rugosan species in its adult characters.

CONCLUSIONS

1. Lateral increase is overwhelmingly the most common type of colony development in rugose and tabulate corals. Axial increase is known in only a very few rugose species, and coenenchymal increase occurs only in heliolitid corals.

2. Peripheral increase, which occurs uncommonly in solitary and colonial Rugosa, is a multiple form of rejuvenescence rather than a typical mechanism of colony development. Only uncommonly are more than one or two generations of offsets produced by this type of increase and in most colonial corals, lateral increase also occurs in the colony. Peripheral increase is invariably parricidal in nature.

3. Partitions and dividing walls are the two type of walls separating offset from parent during lateral increase. In fasciculate and some cerioid species the following possibilities may occur; a) a partition may develop, followed by its replacement by a dividing wall, or b) only the dividing wall is formed. In other cerioid species and probably in most or all astreoid, thamnasteroid and aphroid colonies, only the partition is formed. In axial and peripheral increase, only the dividing wall is formed. Implications regarding soft parts in relation to the two types of walls are that a com-

mon sheet of ectoderm (coenosarc) extends over the partition, but the dividing wall is formed by the ectoderms of two separate polyps in apposition.

4. Observations to date indicate that the study of blastogeny has great potential in the solution of phylogenetic problems. This avenue of research is at least equal in value to other aspects of study of colonial corals.

5. Study of the blastogeny in *Favistina* and *Palaeophyllum* has shown that the five species examined are a closely related group. During lateral increase, a) only a dividing wall is developed, b) the axial plane of the offset is oriented towards the axis of the parent with the counter septum positioned on the peripheral wall, and c) insertion is of a subregular rugosan type with minor septa either appearing after most of the major septa, or somewhat alternating with them during insertion. Tertiary septa in two specimens of *Palaeophyllum* are noted for the first time in Ordovician corals. In spite of *Favistina* bearing a close resemblance to *Foerstephyllum*, comparison of the blastogeny in both has shown that they are fundamentally dissimilar to one another. There is tenuous evidence in one species of *Foerstephyllum*, however, to suggest that some relationship may exist between the two genera.

J. Fedorowski

Uniwersytet Poznański
Pracownia Paleozoologii
ul. S. Mielżyńskiego 27/29
61-725 Poznań
Poland

March, 1975

R. K. Jull

Department of Geology
University of Windsor
Windsor, Ontario
Canada

March, 1975

REFERENCES

- BOLTON, T. E. 1972. Geological map and notes on the Ordovician and Silurian Litho- and Biostratigraphy, Anticosti Island, Quebec. — *Pap. Geol. Surv. Canada* 71—19, 1—44.
- BROWNE, R. G. 1964. The coral horizons and stratigraphy of the Upper Ordovician Richmond Group in Kentucky west of the Cincinnati Arch. — *J. Paleont.* 38, 385—392.
- 1965. Some Upper Cincinnatian (Ordovician) colonial corals of north-central Kentucky. — *Ibidem*, 39, 1177—1191.
- COATES, A. G. & OLIVER, W. A., Jr. 1973. Coloniality in Zoantharian corals. — *In*: R. S. Boardman, A. H. Cheetham & W. A. Oliver, Jr. (Eds.) *Animal Colonies*, Dowden, Hutchinson and Ross, 3—27, Stroudsburg.
- DOBROLYUBOVA, T. A. 1958. Nizhnekamennougolnye kolonialnye chetyrekhluchevye koralny Russkoi Platformy. — *Trudy Paleont. Inst.* 70, 1—224.

- FEDOROWSKI, J. 1965. Lower Permian Tetracoralla of Hornsund, Vestspitsbergen. — *Studia Geol. Pol.* **17**, 1—173.
- 1970. Some Upper Viséan columnate tetracorals from the Holy Cross Mountains (Poland). — *Acta Palaeont. Pol.* **15**, 549—613.
- & GORIANOV, V. B. 1973. Redescription of tetracorals described by E. Eichwald in "Palaeontology of Russia". — *Ibidem*, **18**, 3—70.
- FLOWER, R. H. 1961. Part 1, Montoya and related colonial corals. Part 2, Organisms attached to Montoya corals. — *New Mexico State Bur. Mines Min. Res. Mem.* **7**, 1—229.
- FOERSTE, A. P. 1909. Preliminary notes on Cincinnati and Lexington fossils. — *Bull. Denison Univ. Sci. Labs.* **14**, 289—324.
- FOMICHEV, V. D. 1953. Korally Rugosa i stratigrafiya sredne i verkhnekamennougolnykh i permskikh otlozheniy Donetskogo basseina. — *VSGI*, 1—622.
- HALL, J. 1847. Paleontology of New York, 1 (Natural History of New York, Pt. 6), 1—338, Albany.
- HILL, D. 1935. British terminology for Rugose corals. — *Geol. Mag.*, **72**, 481—519.
- 1956. Rugosa. — In: R. C. Moore (Ed.), *Treatise on Invertebrate Paleontology, Part F, Coelenterata*. Geol. Soc. Amer. and Univ. Kansas Press, 233—324, Lawrence.
- JULL, R. K. 1965. Corallum increase in Lithostrotion. — *Palaeontology*, **8**, 204—225.
- 1967. The hystero-ontogeny of Lonsdaleia McCoy and Thysanophyllum orientale Thomson. — *Ibidem*, **10**, 617—628.
- 1973. Ontogeny and hystero-ontogeny in the Middle Devonian rugose coral Hexagonaria anna (Whitfield). — In: R. S. Boardman, A. H. Cheetham & W. A. Oliver, Jr. (Eds.), *Animal Colonies*, Dowden, Hutchinson & Ross, 59—68, Stroudsburg.
- in press. Septal development during hystero-ontogeny in the Ordovician tabulate coral Foerstephyllum. — *J. Paleont.*
- KOCH, G. v. 1833. Die ungeschlechtliche Vermehrung (Theilung und Knospung) einiger palaeozoischen Korallen. — *Palaeontographica*, **29**, 325—348.
- LIBERTY, B. A. 1969. Palaeozoic geology of the Lake Simcoe area, Ontario. — *Mem. Geol. Surv. Canada*, **355**, 1—201.
- LINDSTROM, G. 1899. Remarks on the Heliolitidae. — *Kongl. Svensk. Akad. Handl.* **32**, 1—140.
- NICHOLSON, H. A. 1875. On Favistella stellata and Favistella calicina, with notes on the affinities of Favistella and allied genera. — Rept. 44 Meeting Brit. Assoc. Adv. Sci. (Belfast, 1874). Notices and Abstr. Miscell. Commun. Sect., 89—90, London.
- NOWIŃSKI, A. in press. Tabulata and Chaetetida from the Devonian and Carboniferous of Southern Poland. — *Palaeont. Pol.* **35**.
- OLIVER, W. A., Jr. 1963. A new Kodonophyllum and associated rugose corals from the Lake Metapedia area, Quebec. — *U. S. Geol. Surv. Prof. Pap.* 414-G, 1—9.
- 1968. Some aspects of colony development in Corals. — *Mem. Paleont. Soc.* **2**, 16—34.
- PICKETT, J. 1967. The Lower Carboniferous coral faunas from the New England district of New South Wales. — *Mem. Geol. Surv. N. S. W. Palaeont.* **15**, 1—38.
- RÓZKOWSKA, M. 1960. Blastogeny and individual variations in tetracoral colonies from the Devonian of Poland. — *Acta Palaeont. Pol.* **5**, 1—34.
- SCHOUPPE, A. v. & OEKENTORP, K. 1974. Morphogenese und Bau der Tabulata unter besonderer Berücksichtigung der Favositida. — *Palaeontographica*, **A**, **145**, 79—194.
- SMITH, S. 1916. The genus Lonsdaleia and Dibunophyllum rugosum (McCoy). — *Q. J. Geol. Soc.* **71**, 218—272.

- & LANG, W. G. 1931. Silurian corals. — The genera *Xiphelasma*, gen. nov., and *Acervularia*, Schweigger, with special reference to *Tubiporites tabulatus*, Schlotheim, and *Diplophyllum caespitosum*, Hall. — *Ann. Mag. Nat. Hist.* (Ser. 10), **8**, 83—94.
- & RYDER, T. A. 1926. The genus *Corwenia* gen. nov. — *Ann. Mag. Nat. Hist.* (Ser. 9) **17**, 149—159.
- 1927. On the structure and development of *Stauria favosa* (Linnaeus). — *Ibidem* (Ser. 9), **20**, 337—343.
- & TREMBERTH, R. 1929. On the Silurian corals *Madreporites articulatus* Wahlenberg, and *Madrepora truncata* Linnaeus. — *Ibidem* (Ser. 10), **3**, 361—376.
- SORAU, J. E. 1971. Microstructure in the exoskeleton of some Rugosa (Coelenterata). — *J. Paleont.* **45**, 23—32.
- STASIŃSKA, A. 1967. Tabulata from Norway, Sweden and from the erratic boulders of Poland. *Palaeont. Pol.* **18**, 1—112.
- STUMM, E. C. 1967. Growth stages in the Middle Devonian rugose coral species *Hexagonaria anna* (Whitfield) from the Traverse Group of Michigan. — *Contr. Univ. Michigan Mus. Paleont.* **21** (5), 105—108.
- TING, T. H. 1940. Ueber die Gattung *Stauria* unter besonderer Berücksichtigung der Kreuzsausbildung. — *Bull. Geol. Soc. China* **20**, 49—56, Chungking.
- TWENHOFEL, W. H. 1928. Geology of Anticosti Island. — *Mem. Geol. Surv. Canada*, **154**, 1—481, Ottawa.
- ULITINA, L. M. 1973. Razvitiye kolonii *Phillipsastrea hennahi*. — *Paleont. Zur.* **1**, 97—102.
- WELLS, J. W. 1937. Individual variation in the rugose coral species *Heliophyllum halli* M. E. & H. — *Paleontographica Amer.* **2** (6), 1—22.
- WEYER, D. 1972. Zur Morphologie der Rugosa (Pterocorallia). — *Geologie*, **6**, 710—737.
- WRIGHT, A. J. T. 1966. Cerioid *Syringophyllidae* (Tetracoralla) from Devonian strata in the Mudgee district, New South Wales. — *Proc. Linnean Soc. N. S. W.* **90**, 263—273.

JERZY FEDOROWSKI & ROBERT K. JULL

PĄCZKOWANIE BOCZNE U PEWNYCH GÓRNOORDOWICKICH RUGOSA I UWAGI O PĄCZKOWANIU U KORALI PALEOZOICZNYCH

Streszczenie

Znaczenie pączkowania dla rozwiązania problemów filogenezy i taksonomii Rugosa jest niezaprzeczone pomimo ciągle niedostatecznej ilości szczegółowych badań. Pączkowanie lateralne (boczne) jest najbardziej powszechne spośród zbadanych dotychczas typów pączkowania. Pączkowanie osiowe występuje sporadycznie, a pączkowanie peryferyczne, również rzadko spotykane, można określić jako odmłodzenie,

w którym powstaje prawie równocześnie kilka osobników. Może ono występować zarówno w koloniach normalnych, jak i w koloniach zaczątkowych. Pączkowanie cenenchymatyczne opisano dotychczas tylko u *Heliolitida*. Dostępne dane wskazują, że istnienie pączkowania t.zw. syringoporoidalnego i międzyściennego jest biologicznie nie do zrealizowania.

W wyniku pączkowania bocznego młody koralit zostaje oddzielony od koralita macierzystego bądź ścianą tymczasową, bądź stałą. Ściana tymczasowa jest wydzielana przez ciągły fałd ektodermy bazalnej, wspólny dla koralita macierzystego i potomnego. Ścianę stałą budują dwa, całkowicie oddzielone polipy. Kolonie cerioidalne mogą być utworzone bądź ze ściśle przylegających do siebie polipów oddzielonych ścianami stałymi, bądź tworzące je polipy łączą się ponad ścianami tymczasowymi, tworząc wspólne ciało kolonii.

Opisane w niniejszej pracy pączkowanie boczne u rodzajów *Favistina* i *Palaeophyllum* z górnego ordowiku Ameryki Północnej wykazało, że polipy oddzielone są u nich ścianami stałymi. Osie symetrii pączków są prostopadłe do koralitów macierzystych, przy czym septa przeciwległe są osadzone na ścianach zewnętrznych. Aparaty septalne zakładane są zgodnie z zasadą kwadrantów. U kilku okazów rodzaju *Palaeophyllum* stwierdzono występowanie septów III rzędu, znanych dotychczas tylko u *Rugosa* z górnego karbonu lub młodszych.

ЕЖИ ФЕДОРОВСКИ & РОБЕРТ К. ДЖУЛЬ

БОКОВОЕ ПОЧКОВАНИЕ У НЕКОТОРЫХ РУГОЗ ВЕРХНЕГО ОРДОВИКА И ПРИМЕЧАНИЯ НА ТЕМУ ПОЧКОВАНИЯ У ПАЛЕОЗОЙСКИХ КОРАЛЛОВ

Резюме

Виды почкования ругоз имеют бесспорно важное значение в решении проблем их филогенеза и таксономии, несмотря на недостаток детальных данных по изучению этих организмов. Среди исследованных до сих пор разновидностей, наиболее часто наблюдалось латеральное (боковое) почкование. Осевое почкование встречается спорадически, а периферическое почкование, наблюдающиеся также редко, можно рассматривать в качестве омоложения, во время которого почти одновременно развивается несколько особей. Оно встречается как в нормальных, так и в зачаточных колониях. Цененхимальное почкование было описано до сих пор лишь у *Heliolitida*. Имеются данные, что образование так наз. сиригнородного и межстенного почкования биологически невозможно.

В процессе бокового почкования молодой кораллит отделяется от материнского кораллита посредством временной или постоянной стенки. Временная стенка выделяется сплошной складкой базальной эктодермы, которая является общей для родителя и дочери. Постоянная стенка нарастается двумя полностью отделенными друг от друга полипами. Цериоидные колонии могут состоять из полипов тесно примыкающих друг к другу и разделенных постоянными стенками или же образующие их полипы соединяются над временными стенками, образуя общее тело колонии.

Описанное в настоящей работе боковое почкование у родов *Favistina* и *Palaeophyllum* из верхнего ордовика Северной Америки доказывает, что полипы отделены здесь постоянными стенками. Оси симметрии почек перпендикулярны к родительским кораллитам, причем противоположные септы располагаются на внешних стенках. Септальные аппараты основываются по принципу квадрантов. У нескольких экземпляров рода *Palaeophyllum* наблюдались септы III порядка, которые до этого были известны лишь по верхнекарбонским и младшим ругозам.

EXPLANATION OF PLATES

Plates IX—XIII; all figures approx. $\times 10$. Numbers below figures are cumulative distances of distal growth in μm . C = cardinal septum; K = counter septum; A = alar septum. Plates XIV—XV: all figures are scanning electron micrographs of surfaces etched 30 seconds in 2.5% formic acid.

Plate VIII

Favistina stellata (Hall)

Fig. 1. Specimen No. BM R36207, Saluda Member, Whitewater Formation, Richmondian Bardostown, Kentucky. *a* — transverse section showing typical cerioid colony, $\times 2$; *b* — longitudinal section, $\times 2$. Corallites of this specimen are slightly larger and bear a few more septa than in other specimens of the species studied.

Favistina calicina (Nicholson)

Fig. 2. Specimen No. BM R31861, Upper Member (Meaford), Gergian Bay Formation, Richmondian, Steetsville, Ontario. *a* — transverse section showing partly packed corallites, $\times 2$; *b* — longitudinal section showing corallites becoming fasciculate in upper part of colony, $\times 1$.

Palaeophyllum cf. *vaurealensis* Twenhofel

Fig. 3. Specimen No. GSC 31353, Vauréal Formation, Richmondian, Anticosti Island, Quebec. *a* — transverse section, showing cateniform arrangement of corallites, $\times 2$; *b* — longitudinal section, $\times 2$.

Palaeophyllum vaurealensis Twenhofel, 1928 *sensu* Bolton, 1972

Fig. 4. Specimen No. GSC 31352, same locality and horizon as Fig. 3. *a* — transverse section, showing open cateniform arrangement of corallites; *b* — longitudinal section, $\times 2$; *c* — detail of wall showing tertiary septa equal in length to minor septa, $\times 15$.

Palaeophyllum sp.

Fig. 5. Specimen No. GSC 31355, same locality and horizon as Fig. 3. *a* — transverse section, showing tightly packed corallites with some open spaces, $\times 2$; *b* — longitudinal section, $\times 2$.

Plate IX

Lateral increase in *Palaeophyllum vaurealensis* Twenhofel, 1928 *sensu* Bolton, 1972

Fig. 1. Specimen No. GSC 31352, Vauréal Formation, Richmondian, Anticosti Island, Quebec. *a* — region of increase before the start of blastogeny; *b-g* — hystero-brephic stage; *b* — major septa are divided into axial and peripheral parts; *c* — dividing wall starts to form; *c-f* — suppression of the peripheral parts of parent septa in offset and extension of the dividing wall; *g* — cardinal-counter septa are nearly united, insertion of alar septa followed by earliest metasepta in cardinal quadrants; *h-m* — hystero-neanic stage; counter-lateral septa are prominent and insertion is accelerated in cardinal quadrants; *o-p* — late neanic stage.

Lateral increase in *Palaeophyllum* sp.

Fig. 2. Specimen No. GSC 31354, same locality and horizon as Fig. 3. *a* — morphology of parent corallite with one discontinuous major septum in the region of increase; *b-d* — hystero-brephic stage; *b* — pseudo-septal pinnacle present; *c-d* — dividing wall develops along the trace of a tabula lying between offset and parent, and cardinal septum is first septum inserted; *e-f* — hystero-neanic stage showing late appearance of counter septum and one alar septum; *g* — late neanic stage, with septa more typical of adult stage.

Plate X

Lateral increase in *Palaeophyllum* cf. *vaurealensis* Twenhofel

Fig. 1. Specimen No. GSC 31353, Vauréal Formation, Richmondian, Anticosti Island, Quebec. *a* — morphology of parent corallite with thickened wall in the region of increase; *b-f* — hystero-brephic stage, showing septal pinnacle and start of dividing wall development; *d-f* — counter septum is lengthened and flanking septa are inserted; *g-o* — hystero-neanic stage; *g-j* — completion of dividing wall, lengthening of counter septum to meet the cardinal septum, prominent counter-lateral septa, and rapid insertion of major and minor septa in counter quadrants; *k-n* — insertion of metasepta on dividing wall, lengthening of all major septa to meet at the axis; *p-s* — late neanic stage; *r-s* — development of first short tertiary septa and formation of an aulos-like septal arrangement opening to the cardinal or nearby septum.

Lateral increase in two offsets of *Favistina stellata* (Hall)

Fig. 2. Specimen No. BM R602B, Saluda Member, Whitewater Formation, Richmondian, Bardstown, Kentucky. Of the two offsets visible, development in offset B (on right) is rapid and in A (on left) it is very slow. In offset B axial septa

appear early during hystero-ontogeny (*a-c*), and septal insertion is accelerated in the counter quadrants. Other than the cardinal septum, septa are absent on the dividing wall during the first 5 mm of growth. Offset A has a comparatively long aseptate period. The first three septa are inserted almost simultaneously on its dividing wall; these are the cardinal and two alar septa. In neither offset A or B are major and minor septa inserted alternately.

Plate XI

Lateral increase in *Favistina stellata* (Hall)

Fig. 1. Specimen No. BM R602C, Saluda Member, Whitewater Formation, Bardstown, Kentucky. *a*—morphology of parent corallite; *b-c*—hystero-brephic stage showing unusually early development of counter and counter-lateral septa, and rapid secretion of dividing wall; *d-j*—hystero-aneic stage, showing a counter-lateral septum united to the cardinal septum resulting in a false impression of united axial septa. The very accelerated rate of insertion in the counter quadrant may be partly due to the oblique sections through the offset. Except for the cardinal septum, septa are absent on the dividing wall until the end of this stage; *k*—late neanic stage.

Fig. 2. Specimen No. BM 24736B, same horizon and locality as (Fig. 1. *a*—region of increase before the start of blastogeny; *b-i*—hystero-brephic stage; *b-c*—interruption of major septum in the region of increase and gradual suppression of inherited septa in offset, showing in 2c morphology of parent corallite; *d*—pseudo-septal pinnacles are secreted on either side of the axial end of a major septum; *e-g*—development of the dividing wall and insertion of the counter septum (2e); *h-i*—cardinal septum is second septum inserted. The counter-laterals are simultaneously inserted next. Minor septa are absent in the wall.

Plate XII

Lateral increase in two corallites of *Favistina calicina* (Nicholson)

Fig. 1. Specimen No. BM R31861, Upper Member (Meaford), Georgian Bay Formation, Richmondian, Streetsville, Ontario, *a*—part of the parent corallite showing an offset. Offset in figs *b-o* arises in lower-right of this corallite where a major septum is absent; *b-g*—hystero-brephic stage; *b-d*—dividing wall is rapidly constructed and inherited septa are suppressed. Axial septa are inserted before the dividing wall is complete (1c); *e-f*—remaining protosepta and first metasepta are inserted; *h-k*—hystero-aneic stage. Counter septum, which is long at the beginning of this stage, becomes almost completely reduced and is then reconstructed. In 1k, a few minor septa are present in the wall at the end of this stage; *l-o*—late neanic stage.

Fig. 2. Same specimen as fig. 1 *a-i*—hystero-brephic stage; *a*—major septum of parent is divided into axial and peripheral parts and pseudo-septal pinnacles are secreted; *b*—inherited septa are suppressed and dividing wall is quickly developed; *c-e*—axial septa are inserted after the dividing wall is complete, forming a distinctive bisepal stage; *f-j*—insertion of counter-lateral septa followed by alar septa; *j-k*—hystero-aneic stage. Metasepta are inserted in a regular pattern in all quadrants at almost the same time. Minor septa are not visible in the wall.

Plate XIII

Lateral increase in *Favistina stellata* (Hall)

Fig. 1. Specimen No. BM R36207, Saluda Member, Whitewater Formation, Richmondian, Bardstown, Kentucky. *a*—morphology of parent corallite; *b-j*—hystero-brephic stage; *d*—counter septum and one counter-lateral septum are inserted; *e-g*—dividing wall is slowly developed from both sides of the common region between offset and parent corallite towards the centre. First alar septum and second counterlateral septum are inserted one after another, and first minor septum appears close to the counter septum; *h-j*—dividing wall is completed and cardinal septum inserted on it, with the second alar septum inserted next; *k-l*—hystero-neanic stage. The first metasepta are inserted, one in each of the cardinal and counter quadrants. Minor septa are visible between almost all majors.

Lateral increase in *Favistina calicina* (Nicholson)

Fig. 2. Specimen No. BM R56435B, Upper Member (Meaford), Georgian Bay Formation, Richmondian, Credit River, Ontario. *a-j*—hystero-brephic stage; *a-c*—two major septa of parent are separated into axial and peripheral ends and a pseudoseptal pinnacle is formed between them; *d-f*—dividing wall is constructed and axial ends of parent septa are attached to it. The cardinal septum on the dividing wall is first septum inserted in the offset; *g-i*—cardinal septum is extended to nearly meet the peripheral wall and alar septa, followed by one of the counter-laterals are inserted; *j*—counter septum is inserted and united to the cardinal septum, and second counter-lateral septum is inserted at the same time as the first metaseptum in cardinal quadrant; *k-n*—hystero-neanic stage, with insertion of a few metasepta and union of most of the major septa in the axial region of corallite.

Plate XIV

Palaeophyllum vaurealensis Twenhofel, 1928, *sensu* Bolton 1972

Fig. 1. Specimen No. GSC 31352, Vauréal Formation, Richmondian, Anticosti Island, Quebec. Transverse views of corallite. *a*—wall showing two major septa (ma.s) at either end, a short minor septum (mi.s) at centre, tertiary septum (t.s) left of centre, and elongate crystals of wall between septum, $\times 75$; *b*—closer view of same area, showing major septum on left and tertiary septum on right, $\times 150$; *c*—same tertiary septum showing wall crystals flanking and arched over its axial end at the top, $\times 350$; *d*—detail of a corallite wall not in contact with a neighbouring corallite. The base of a major septum is visible at the bottom. A row of subrectangular crystals representing the epitheca (ep) is visible forming the edge of the wall at the top, $\times 350$.

Palaeophyllum cf. *vaurealensis* Twenhofel

Fig. 2. Specimen No. GSC 31353, same horizon and locality as fig. 1. Transverse views of corallite. *a*—intercorallite wall with minor septum at left and base of major septum at right. Running up the centre of the corallite is a row of elongate crystals representing the epitheca, $\times 150$; *b*—detail of same area, showing epitheca bounded by other wall crystals, $\times 500$.

Plate XV

Palaeophyllum cf. vaurealensis Twenhofel

- Fig. 1. Specimen No. GSC 31353, Vauréal Formation, Richmondian, Anticosti Island, Quebec. Transverse view of corallite. *a* — dividing wall of offset showing major septum extending down into offset and major and minor septa extending up into parent corallite, $\times 75$; *b* — detail of same area, showing the base of the same major septum in offset, and a row of subrectangular crystals, the epitheca (ep), extending from the upper left-hand corner to the tip of the arrow, $\times 350$.

Favistina stellata (Hall)

- Fig. 2. Specimen No. BM R36207, Saluda Member, Whitewater Formation, Bardstown, Kentucky. *a* — transverse view of offset with partly developed dividing wall, pseudoseptal pinnacle and a number of septa, $\times 20$; *b* — detail of the end of the dividing wall. A slightly sinuous epitheca (ep) might be visible in the wall, $\times 200$.

Palaeophyllum vaurealensis Twenhofel, 1928 *sensu* Bolton 1972

- Fig. 3. Specimen No. GSC 31352, same horizon and locality as fig. 1. Transverse view of centre of intercorallite wall (iw) showing a double row of subrectangular epithecal crystals, $\times 500$.

Lithostrotion pauciradiale (McCoy)

- Fig. 4. Specimen No. SM A1999, Carboniferous Limestone, Viséan, Settle, Yorkshire. Transverse view of the partition lying between an offset (lower-right) and parent (upper-left). The partition is lightly constructed of sclerenchyme infilling between overlapping and united ends of septa, $\times 35$.

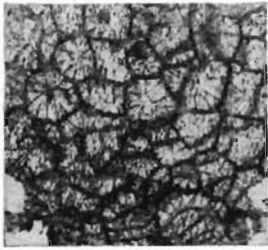

1a

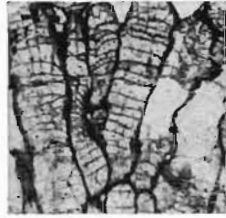

1b



2a

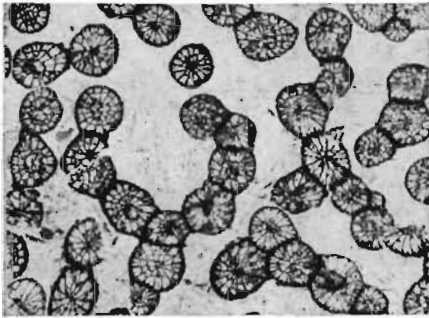

3a

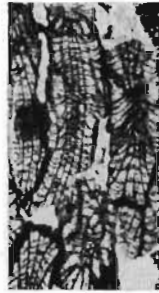

3b

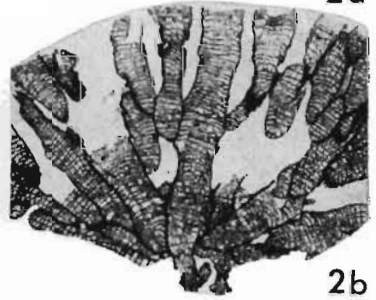

2b

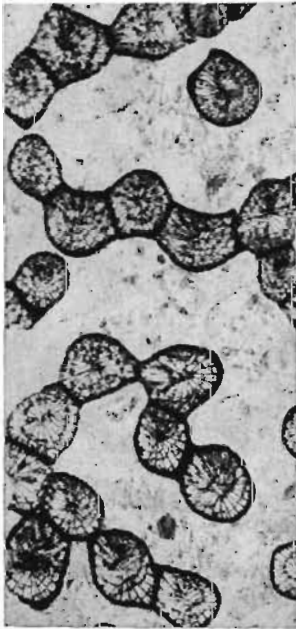

4a



4b

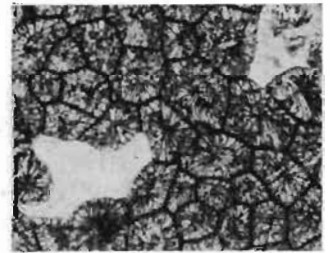

5a

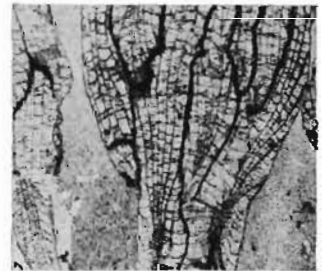

5b

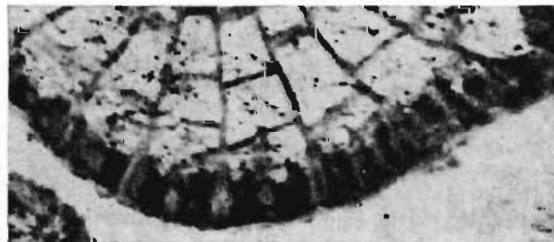

4c

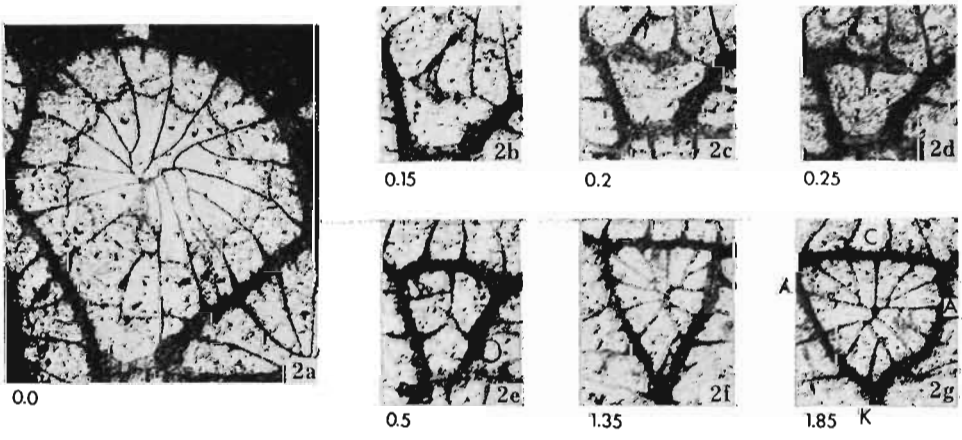
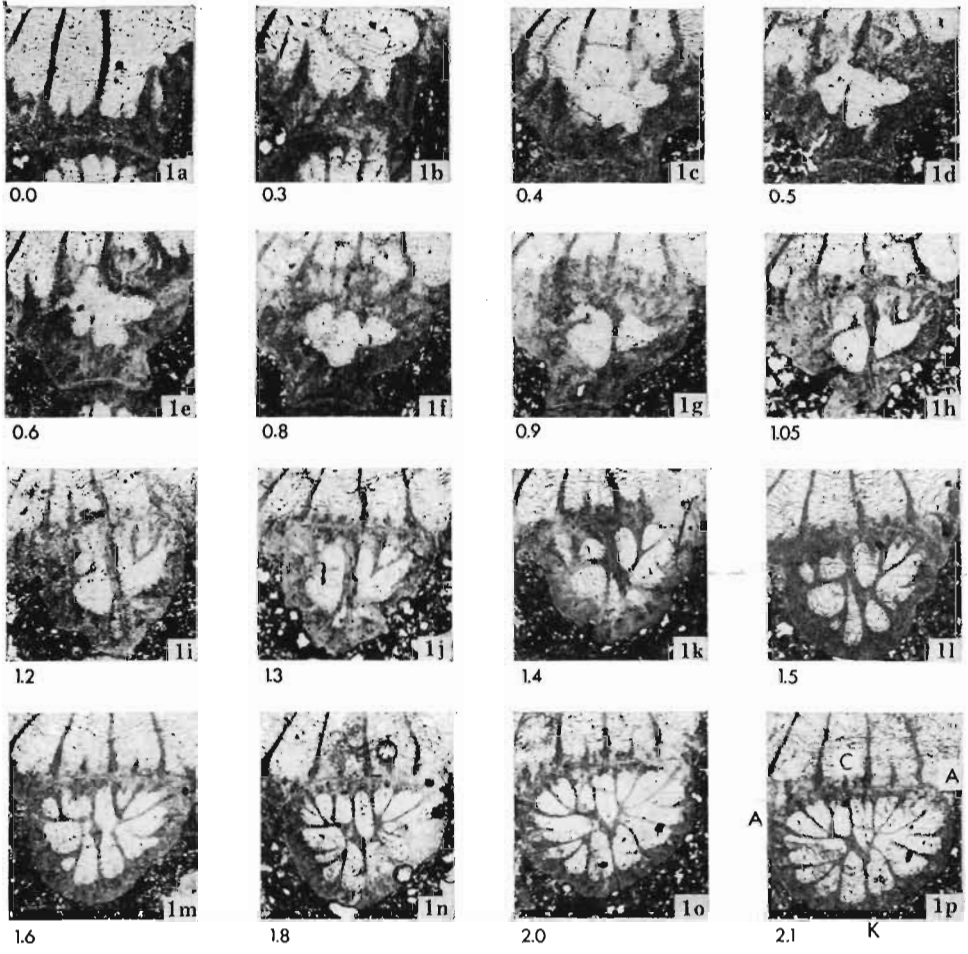

Phot. A. Pietura

