

85
N91-19198 !

Review of Thin Film Solar Cell Technology and Applications for Ultra-Light Spacecraft Solar Arrays

Geoffrey A. Landis*
*NASA Lewis Research Center
Cleveland, OH*

*National Research Council Resident Research Associate at NASA Lewis

Introduction

In this paper developments in thin-film amorphous and polycrystalline photovoltaic cells are reviewed and discussed with a view to potential applications in space. Two important figures of merit are discussed: efficiency (i.e., what fraction of the incident solar energy is converted to electricity), and specific power (power to weight ratio).

Current Generation Technology

Solar cells currently used in space are single-crystal silicon and gallium arsenide cells [ref. 1]. Silicon solar cell performance has recently had major gains, and the previous estimates for the "limits" to performance have had to be revised upwards. New estimates taking into account new technologies such as light trapping and surface passivation suggest achievable efficiencies of up to 22%, with the best cells to date having already achieved efficiency of 20%.

The best GaAs cells are roughly 21.4% efficient under space (AM0) conditions [ref. 2]. Cells manufactured using current production technology have a somewhat lower efficiency. LSI in Japan has demonstrated production runs of 120 cells with an average efficiency of 20% AM0 [ref. 3]. For GaAs on Ge, an efficiency of 21.7% has been measured under the simulated AM0 spectrum [ref. 4,5]. Unfortunately, high altitude tests have shown that the actual space solar spectrum does not contain as much long wavelength irradiance as simulations, and the actual efficiency is lower than the tested values [ref. 6]. This problem can potentially be eliminated either by improving the Ge subcell or by adding Al to the GaAs to let through more light. Tobin et al. calculate a limit efficiency for this cell design of 35.7%, compared to 27.5% for GaAs alone [ref. 5].

Next generation technology will likely improve these efficiency values. For ultrathin silicon cells with light trapping and surface passivation, the optimum thickness decreases and the efficiency increases. For highest end-of-life efficiency, the optimum thickness of silicon cells may be as low as 2 microns, leading to potentially very high specific power. The radiation tolerance of such ultrathin cells may be extremely good,

since the thickness is less than the diffusion length even after radiation damage. Calculations predict that such ultrathin Si cells have efficiency and radiation tolerance as good as that of III-V solar cells [ref. 7].

Considerable interest has recently been focussed on indium phosphide (InP) as a new high efficiency solar cell material. Cells with efficiencies as high as 18.8% AM0 [ref. 8] have been produced [ref. 9]. A major reason for the interest in the material is that InP is considerably more resistant to radiation damage than silicon or GaAs.

Finally, it should be noted that efficiency can be increased by concentrating the incident sunlight, either by means of a mirror or a lens. This approach will not be discussed in detail here.

Thin-Film Solar Cells

An alternative to the conventional single crystal solar cell is the thin-film solar cell. Thin-film solar cells are made from thin (1 to 5 micron) polycrystalline or amorphous semiconductor layers deposited on an inert substrate or superstrate material. The materials used are high absorption direct bandgap semiconductors; the high absorption constant allows essentially complete absorption of the light within the first micron or so of the material. Recently thin film solar cells have been the topic of intense research for low-cost terrestrial electricity production, since the low materials usage and potential for high throughput, automated deposition allows the production cost to be extremely low. Initial research efforts focussed on amorphous silicon; recently copper indium selenide and cadmium telluride have shown extremely good experimental results. For space applications, however, little work has been done. The potential use of thin film solar cells for space will be a topic of research under the surface power task of the NASA "Pathfinder" program to develop enabling technology for future NASA missions.

Thin-film solar cells can be made from a wide variety of materials including ternaries and quaternaries; many of these have not been extensively studied. The achievable efficiency of a solar cell material will depend on the characteristic energy bandgap of the material. An idealized calculation of achievable efficiency versus bandgap is shown in figure 1, with the bandgaps of some of the important solar cell materials indicated (after Loferski, [ref. 10]). For the technologically well-developed materials, such as silicon and GaAs, the efficiencies on this chart are very close to the achieved efficiencies (*e.g.*, 21.4% for GaAs, 20% for Si). For thin film materials, achieved efficiencies as yet fall well below these values. This is for two reasons. First, Si and GaAs have received the benefit of extensive materials development research done for the electronics industry, and are technologically very well understood materials, while thin film materials are relatively new and have been comparatively little researched. Second, because the thin film materials are polycrystalline or amorphous, there are additional sources of efficiency loss due to grain boundary effects and the effects of

structural disorder. It is as yet unknown whether the ultimate efficiencies of these materials will approach those of the single crystal materials.

Since the absorption coefficients of all of the materials discussed is very high, the cells can be made extremely thin, typically a few microns, compared to several hundred microns thickness required for conventional silicon solar cells. This means that the technology could potentially be extremely low weight, if the cells can be deposited on low mass substrates (or superstrates). However, the current technology development programs are directed at terrestrial use, for which the preferred substrate is typically 1/4 inch thick glass; cheap and rugged but not light. There is little or no research on alternative, lightweight substrates

Advantages of thin-film solar cells are:

- high radiation tolerance
- high specific power; potentially in the kilowatt/kilogram range.
- large area solar cells with integral series interconnections.
- flexible blankets
- large (by spacecraft standards) body of array manufacturing experience.
- low cost.

The disadvantages of thin-film solar cells are:

- lower efficiency
- lack of spacecraft experience
- not currently produced on lightweight substrates.

Experimental measurements on thin film solar cells are almost always quoted for a solar spectrum filtered by passage through the atmosphere (Air Mass 1.5, or AM1.5 spectrum). Almost no measurements have been made of cells under the space (Air Mass Zero, or AM0) spectrum. Efficiency measured under space sunlight is lower than that under terrestrial sunlight because most of the added energy available in space is in the infrared and ultraviolet regions, to which solar cells are generally not very responsive. The conversion from AM1.5 to AM0 efficiency typically involves an efficiency decrease of about 20 percent for cells with bandgaps in the range of 1 to 1.5 eV, varying slightly with the spectral response of the solar cell in question. For example, for one amorphous silicon cell discussed in the literature [ref. 11], conversion of AM1.5 efficiency to AM0 is by a multiplicative factor of 0.80. In this paper efficiency figures quoted at AM1.5 have all been converted to AM0 efficiency using an assumed conversion factor of 0.80.

While thin-film technologies have not yet been demonstrated in space, there is a very large (by space standards) manufacturing base on the Earth: tens of megawatts per year for a-Si, a rapidly increasing capability of perhaps one megawatt per year for CuInSe₂, and around a hundred kilowatts per year for CdTe.

Very little actual flight experience is available on thin-film cells. CuInSe₂ and a-Si cells are both now flying on the LIPS-III satellite [ref. 12].

Table 1 summarizes the historical and projected efficiency of some of the most important solar cell types.

CdS/Cu₂S

The first thin-film solar cell developed was the heterojunction cadmium sulfide/copper sulfide cell [ref. 13,14]. The best achieved efficiency on these cells is about 7% [ref. 15], with very high radiation tolerance. These cells were made obsolete by the development of more stable and higher-efficiency thin-film materials.

Copper Indium Selenide

Currently the leading technology for thin film photovoltaics is copper indium selenide [ref. 16]. As of 1989, an efficiency of 10.4% AM0 has been achieved by Arco Solar (again using the factor of 0.8 to convert from values measured at AM1.5 of 13% [total area] 14.1% [active area]). 12% efficiency can be confidently predicted in the near term [ref. 17]. Figure 2 (courtesy ARCO Solar) shows the electrical characteristics of the best CuInSe₂ cell. Modules can be made with integral interconnection of the deposited thin-film cells. ARCO Solar, for example, produces large area (4000 cm²) modules [ref. 18] with multiple cells series interconnected on a single substrate.

The bandgap of copper indium selenide is 1.0 eV. This is on the low side of the efficiency maximum shown in figure 1, but still reasonable. It is, as discussed below, nearly ideal for the bottom cell of a cascade.

The absorption constant of CuInSe₂ is extremely high, allowing the possibility of cells as thin as one micron. Existing cells consist of a layer of the active copper indium selenide, typically about 3 microns in thickness; a front contact and heterojunction window of either cadmium/zinc sulfide or zinc oxide plus cadmium sulfide, thickness typically about one micron; and a back contact of molybdenum, typically several thousand angstroms thick. Thus the material has inherently low weight, and the primary mass is that of the substrate onto which the film is deposited.

A wide variety of manufacturing methods have produced ~8% efficiency, including vacuum evaporation, reactive sputtering, and electroplating of the base material onto the substrate. In general, all of these techniques either involve high temperature deposition, or a high temperature post-deposition anneal step. This could be a problem for space applications, where it would be desirable to be able to deposit the cell onto

a thin plastic (e.g., Kapton) substrate. Deposition onto a thin substrate has not been demonstrated to date.

Copper indium selenide has the highest measured tolerance to electron irradiation of any solar-cell material known to date.

Other I-III-VI₂ Compounds

Related I-III-VI₂ semiconductors have also been studied for solar cell use, although not as extensively as CuInSe₂. The goal of investigations has been to identify related semiconductors which have the same ease of manufacturing into thin-film solar cells, but have wider bandgaps and thus presumably higher ultimate efficiency.

Copper gallium selenide is a major candidate for the proposed higher efficiency successor to copper indium selenide. The advantage of CuGaSe₂ is the wider bandgap, 1.67 eV, which is much closer to the optimum for the solar spectrum (see figure 1), and nearly ideal for a cascade upper cell.

While the best experimental results to date are only 4.6% efficiency, the material has not been extensively developed. One known problem is that the CdS heterojunction used for CuInSe₂ absorbs light in the short wavelength end of the spectrum. Since this is more important for the wider bandgap material, a different (wider bandgap) heterojunction material needs to be developed to reach maximum efficiency for CuGaSe₂ [ref. 19,20]. Unless CuGaSe₂ differs electronically from CuInSe₂ in some yet-unknown way, ultimate efficiency for CuGaSe₂ cells should be about 18% better than for CuInSe₂.

Cu(InGa)Se₂ quaternary compounds can be produced with bandgaps intermediate between copper indium selenide and copper gallium selenide. This allows a bandgap variable from 1.0 to 1.67 eV. Such materials can be tailored for a good match to the AM0 spectrum, yet be easier to work with than the wide bandgap CuGaSe₂. Cells made with the In/Ga ternary show performance as good or better than that achieved with CuInSe₂. Boeing has reported efficiencies of 10.5% measured as AM0 results with CuIn_(1-x)Ga_xSe₂ cells where x is on the order of 25% [ref. 21]. Arco Solar and SERI have also reported good results [ref. 22].

Another proposed wide bandgap candidate is copper indium sulfide. CuInS₂ has a bandgap of 1.55 eV, very close to the optimum. It is not a very well studied material, and until recently no good semiconductor properties had been made with the material. The results on CuInSe₂ cells have restimulated interest in the material, and recently thin-film cells have been made with an efficiency of 5.8% AM0 [ref. 23].

Many other I-III-VI₂ ternaries exist; only a minimum amount of research has been done

Cadmium Telluride

A second material which is being extensively studied for thin film solar cells is cadmium telluride. The bandgap of CdTe is 1.5 eV, which is very well matched to spectrum. It is produced in thin-film form by a wide variety of deposition methods. Best solar cell results to date have an AM0 efficiency of about 9.8% [ref. 24].

Like CuInSe₂, it is currently not produced on thin substrates. However, unlike CuInSe₂, most CdTe deposition methods are "superstrate" technologies, where the cell is deposited inverted upon transparent glass, which is used as the front cover. This glass can easily be produced in 50 micron (two mil) sheets. It is also possible that a transparent plastic could be used.

Mixed alloys are also possible in the II-VI₂ system. Ternary alloys of cadmium zinc telluride and cadmium manganese telluride [ref. 25] can be made with a higher bandgap than CdTe; ternary alloys of mercury cadmium telluride can be made with lower bandgap. Mercury cadmium telluride (HgCdTe) ternary cells have been made with efficiency as high as 8.5% AM1.5 [ref. 26]. HgCdTe with high mercury content (low bandgap) is a material which has been well developed for infrared sensors. Transfer of the technology to solar cells should be straightforward. One advantage of HgCdTe is that it is easier to contact than CdTe, and, in fact, the best CdTe cells utilize HgCdTe for the electrical contacts.

Another II-VI₂ compounds which may be useful for thin-film solar cells is cadmium selenide (CdSe) [ref. 27]. The bandgap of CdSe is 1.7 eV, slightly high for a single junction cell, but excellent for the top element of a cascade.

Amorphous silicon

The material referred to as amorphous silicon is actually a mixed alloy of silicon and hydrogen, where the hydrogen incorporation is necessary for good electronic properties and can range from a few percent to as much as 15%.

The material differs from the thin film materials described above in that the crystal is unstructured. The effective bandgap of amorphous silicon can be varied depending on the deposition parameters within a range of about 1.6-1.7 eV. This is well matched to the solar spectrum. The bandgap can be tailored further by addition of carbon to raise the bandgap, and germanium or tin to reduce it, but so far such amorphous silicon alloy cells have not shown as high performance as pure amorphous silicon.

Amorphous silicon solar cells for terrestrial use are the subject of a very large and active research program, currently funded at several million dollars per year. Much of this research will likely be applicable to space. The manufacturing technology base for a-Si is very large by space standards. Amorphous silicon solar cell modules are currently in production by a number of companies at the ten million watts/year

level. This yearly production level is considerably larger than the entire amount of conventional solar cells flown in space.

The best measured efficiency of an amorphous cells under space conditions is currently about 9% AMO for single junction cells. Some better efficiencies have been reported, but not independently verified. Efficiencies of 5% are more typical of what we measure.

A difficulty with amorphous silicon solar cell technology is the light-induced degradation, or Staebler-Wronski effect. First generation a-Si modules experienced about 20% degradation in peak power over two years of exposure to light. The best current a-Si solar cells are more stable, but still experience a 10 to 15% loss of performance. It is believed that future improvements and better understanding of the physics will reduce this degradation still further.

Technology to manufacture amorphous silicon solar cells on lightweight thin substrates has been demonstrated, on thin polymer and metals by ECD [ref. 11], on thin polyimide by 3M [ref. 28], and on thin polyethylene terephthalate by Teijin Ltd [ref. 29]. There is some interest in lightweight, high specific power amorphous Si arrays for space [ref. 11, 30]. The best reported amorphous silicon module manufactured on a thin substrate is that of Hanak *et al.* [11], who reported an efficiency of 4.2% AMO on a 60 by 30 cm module. Despite the modest efficiency, they nevertheless note that the unencapsulated specific power is 2.4 kW/kg, a value which is very impressive by conventional spacecraft standards.

Thin Polycrystalline silicon

A final thin film technology which should be mentioned is thin polycrystalline silicon. Recently results of up to 12.6% AMO have been reported by a proprietary technique developed by Astropower [ref. 31]. Crystalline silicon is an indirect bandgap material and does not have the extremely high absorption constant typical of the other thin-film materials; consequently, a "thin" polycrystalline silicon cell is considerably thicker and heavier than other thin film technologies. The silicon is deposited on a ceramic substrate; due to the high-temperatures typical of most silicon deposition processes it is not clear if it will ever be possible to produce the material on lightweight substrates. Nevertheless, future developments in this technology may make it of interest, especially for the bottom element of a cascade.

Radiation Tolerance of Thin-Film Solar Cells

In general, all of the thin-film solar cell types have exceptionally high radiation tolerance compared to conventional single-crystal cells. A review of radiation damage effects in thin film cells will be published [32].

Thin-film CdS/Cu₂S solar cells showed excellent radiation tolerance, with no degradation in power on exposure to up to 10^{17} 1-MeV electrons/cm² [ref. 33], as well as high tolerance to proton irradiation [ref. 34]. This led to the hope that thin-film cells in general would have high radiation tolerance, an expectation which has for the most part been proven correct.

Thin-film copper indium selenide solar cells have the highest radiation tolerance of any solar cell measured to date. Existing experimental data show no noticeable degradation in performance at 1-MeV electron fluences of up to 10^{16} electrons/cm², a dose equivalent to about 200 years of exposure at geosynchronous orbit if standard coverglass protection is assumed. (In fact, the measured efficiencies actually improved slightly) [ref. 35].

Under 1 MeV proton irradiation, the cells do show some loss of power; to about 90% after 10^{12} protons/cm², as shown in Figure 3 (courtesy Boeing [ref. 36]). This represents about 50 times greater resistance to 1-MeV proton radiation than either Si or GaAs.

The damage from the proton irradiation could be almost completely recovered by a low-temperature anneal. The cells exhibited 95% recovery of initial power after 6 minutes at 225 C.

While it remains to be seen whether the high radiation tolerance will remain for future high-performance versions of the cell technology, this radiation tolerance is so extraordinary that the end of life (EOL) efficiency of even present-day CuInSe₂ cells may outperform conventional cell technologies in some high radiation orbits.

Thin-film cadmium telluride cells have not, to date, been extensively tested for radiation tolerance. Preliminary results of 1-MeV electron irradiation, quoted by Zweibel [ref. 37], show moderately high radiation tolerance with some loss of short circuit current but negligible loss of voltage or fill factor. All of the degradation they saw could be attributed to darkening of the glass superstrates used for the cells, which could be avoided by using radiation tolerant glass. Bernard et al. [ref. 38] also noticed little change in CdTe cell performance at 1-MeV electron fluence of up to $3 \cdot 10^{16}$ /cm².

Amorphous silicon cells from Arco Solar exposed to 1-MeV electrons degraded from 8.57% AM0 to 8% at 10^{15} electrons/cm² [ref. 35]. The efficiency dropped to 5.95% at 10^{16} electrons/cm². The damage could be almost completely removed

with a low temperature anneal; the cells showed 97% recovery after a fifteen minute treatment at 175 °C.

Somewhat worse degradation was found on nip a-Si cells by NASA Langley [ref. 39]; they also found recovery with a 2-hr, 200 °C anneal.

Thin-Film Cascades

Introduction

An important technology for the production of high-efficiency thin film arrays is the ability of thin films to be produced in multibandgap “cascade” structures [ref. 40].

In the cascade structure, short wavelength (high energy) photons are absorbed in a high bandgap material on the top of the solar cell. The high bandgap material is transparent to longer wavelength (low energy) photons, which pass through and are absorbed by a second layer consisting of a photovoltaic material with lower bandgap.

In principle, cascades could consist of an arbitrary number of elements, which would approach complete utilization of the solar spectrum. The largest jump in photon utilization comes from the increase from one bandgap to two. In practice, it is unlikely that thin film materials will be made with more than two cascaded elements, at least in the reasonable future.

In an optimum current-matched two-element cascade, the efficiency can be approximately calculated as equal to the top cell efficiency plus half the bottom cell efficiency. If current matching is not required, the efficiency is approximately equal to the top cell efficiency plus $(1 - J_{sc(top)}/J_{sc(bottom)})$ times the bottom cell efficiency.

The optimum bandgap combination depends slightly on the materials properties; for the air mass zero spectrum, using ideal materials, maximum efficiency of a two element series-connected cascade occurs at bandgaps of 1.75 for the top cell and 1.05 for the bottom cell [ref. 41]. For the efficiencies of figure 1, this results in a maximum efficiency of 33%, about 50% higher than the efficiency of 24.4% calculated for a single bandgap cell.

Cascades can be configured as monolithic, in which the top cell is integrally deposited on the bottom cell (or vice-versa), or mechanically stacked, in which the two sets of cells are formed separately. Electrical interconnections can be set up as two terminal, three terminal, or four terminal configurations. In general, monolithic modules must be two terminal or possibly three terminal devices; while mechanically stacked modules can be configured as four-terminal devices as well. For a two-terminal current-matched cascade, the current through the top cell must equal that through

the bottom. This means that once the bandgap of one component has been chosen, the bandgap of the other is determined.

Four terminal cascades allow separate connection to the top and bottom cells. If the power is taken separately from each set of sub-cells, this connection requires no matching of current. Four terminals also allow monolithic connection in the voltage-matched configuration, with bottom cells connected in series.

The maximum efficiency is almost the same for all configurations. However, the current-matched configuration is very sensitive to the bandgaps, and loses efficiency very rapidly when the matching condition is not exactly met. The four-terminal system is relatively insensitive to the exact bandgap, while voltage-matched configurations are intermediate in sensitivity.

Figure 4A and B show efficiencies calculated by Fan [ref. 41] for cascade solar cells at AM0 in both the series connected and in the independent operation mode. The maximum efficiency is about the same for both, but the independent operation allows a much wider range of bandgaps.

An important element in a monolithic cascade is a shorting junction to connect the base of the top cell to the emitter (or window layer) of the bottom cell to allow current to flow from the first to the second.

The main question about monolithic cascades is whether technology can be developed to deposit the second cell and interconnections without degrading the first cell, either by thermal effects during deposition causing decomposition or interdiffusion of the first cell, or due to material incompatibility, such as might happen if some component of one cell reduces minority carrier lifetime in the other

For cascades where the top cell bandgap is lower than the optimum bandgap for current matching, it is possible to create a current-matched cascade if the top cell is made to pass through some of the light that would normally be absorbed. This is discussed in [ref. 40].

There is a wide range of possible thin-film semiconductors for a two-cell cascade. Only a few, however, have to date shown potential for producing good thin-film solar cells.

Experimental Results

The best currently demonstrated thin-film cascade, reported by ARCO Solar [ref. 42], uses an amorphous silicon top cell on a CuInSe_2 bottom cell. The achieved efficiency is 12.5% AM0. In this cell the two elements were deposited separately, the a-Si on a glass superstrate and the CuInSe_2 on a metal-coated glass substrate, and the two elements optically coupled with a transparent encapsulant. This module configuration is shown in figure 5 (courtesy ARCO Solar). For higher specific power,

it would be desirable to eliminate the intermediate layer by depositing the a-Si cell directly on the CuInSe₂.

An alternative technology, CdTe on CuInSe₂, has shown about 8% AM0 efficiency for a mechanically stacked prototype [ref. 43].

A problem with existing CuInSe₂ technology is that the current solar-cell structures use a heterojunction window layer which may not withstand the temperatures needed to directly deposit a second cell on top. Thus, either a technology must be developed to deposit the CuInSe₂ after the top cell deposition, a low temperature top cell must be used, or a more robust window layer found.

Cascade cells with amorphous silicon alloys for both top and bottom elements have also been demonstrated. Energy Conversion Devices (ECD), has reported an efficiency of 10% measured at Air Mass Zero for a three junction, two bandgap cell [ref. 30].

Future

Bottom Cell Materials

CuInSe₂ is nearly ideal for the bottom cell for a cascade. The bandgap of CuInSe₂ can be modified by alloying with related I-III-VI₂ materials; for example, CuInTe_xSe_(2-x), will have a lower bandgap, with x selected to form the bandgap required; a higher bandgap material can be formed in CuGa_xIn_(1-x)Se₂. This may be important for monolithic cascades requiring current-matched cells.

Mercury-Cadmium Telluride, with a bandgap continuously variable from 0 to 1.5 eV, is also a good candidate for a bottom cell.

Other materials for bottom cells are polycrystalline silicon and crystalline silicon.

Top Cell Materials

The optimum material for the top cell of a two element cascade would have a bandgap near 1.75 eV. Of the wide-bandgap thin-film solar cell materials, CdTe is the most well developed. The bandgap of CdTe, 1.5 eV, is slightly low for an optimum cascade. For a current-matched cascade this could be remedied by use of a "perforated" cell; alternatively, a bottom cell (for example, HgCdTe) with correspondingly lower bandgap could be used and the small penalty for off-optimum performance accepted.

The related ternary alloys with Mn, Cd_xMn_(1-x)Te; Zn, Cd_xZn_(1-x)Te; or Se, CdTe_xSe_(2-x), could be used to increase the bandgap to closer to optimum [ref. 25]. A related wide bandgap material is cadmium selenide, CdSe [ref. 44]. Electronic

properties and performance of solar cells made from these materials are still comparatively uninvestigated.

CuGaSe₂, with a bandgap of 1.7 eV, and CuInS₂, with bandgap 1.5 eV, are also promising choices, as discussed in the previous section.

Amorphous silicon, with an effective bandgap of around 1.6 to 1.7 eV, may also make a good choice. Alloys with Ge, Sn, SiC and SiN can tailor the bandgap as necessary. Amorphous materials have the advantage that tunnel junctions are relatively easily formed. The efficiency and lifetime of these materials require improvements to allow them to be used for efficient elements in cascades, however, it should be noted that intensive research into amorphous silicon alloys is in progress.

While mechanically stacked modules will likely be simpler to build, high specific power arrays will probably require monolithic construction.

Applications

Future thin-film solar cells are likely to have greatly increased specific power at the solar cell level compared to conventional technology solar cells.

Table 2 compares existing and projected efficiency for the best single crystal and thin-film cells (where "current" means for the best cells achieved in the lab, not for cells currently manufactured into space arrays). Table 3 shows these figures converted into specific power at the cell level. These specific powers are for the cell only, not including the radiation shielding, interconnections, support layers, array structure, etc., all of which are major contributors to the actual mass. It must be noted that cell mass is only a small component of the array mass, and thus of array specific power.

Achieved specific power is typically about a tenth of the cell-level specific power. In a well designed structure, the structural mass should be able to be decreased roughly proportionately to the cell mass. As a rule of thumb, the array structural mass is generally roughly equal to the (covered) cell mass. (The rest of the power system—batteries, power conditioners and controllers, etc—contributes an additional mass element which is nearly independent of the array.)

Specific power is not only concern in solar array design. Other criteria include high array stiffness (i.e., resistance to bending during acceleration), high resonant frequency, and low moment of inertia in order to minimize force required for orientation. For all of these parameters higher specific power, by reducing the mass of the solar cells, increases the relevant performance; while lower efficiency, by increasing the size, decreases it. In general, for these parameters the relevant figure of merit scales as product of the specific power and the efficiency.

Low Earth orbit provides a special case, where the drag area is a criterion. For these orbits, efficiency takes on increased importance.

However, for many, and perhaps even most missions, these concerns are secondary compared to the array mass. In this case achieving maximum specific power is the dominant factor in the choice of technology.

System Applications and Missions

The important applications for thin film solar cells are to missions where specific power is a concern or where significant radiation exposure occurs during the course of the mission. While most spacecraft can benefit from increased specific power and radiation tolerance, specific missions for which thin-film photovoltaic arrays may be an enabling technology are solar electric propulsion, a manned Mars mission, and lunar exploration and manufacturing.

For solar electric propulsion, the system performance is directly proportional to the specific power. Accurate pointing is not important during the thrust. One proposed mission for solar electric propulsion is for a low-thrust vehicle to transfer satellites from low Earth orbit to geosynchronous orbit, or from low Earth orbit to lunar transfer. In both cases the orbit is a slowly rising spiral which spends a long time in the radiation belts, and for these missions the potential radiation hardness of thin film cells may be very important. For a Mars unmanned cargo ship, required power levels could be very high (Megawatts), and specific power very important.

A manned Mars mission would require up to 1 MW of power, both for the spacecraft during the journey, and to power the surface base [ref. 45]. For the baseline mission, the transportation cost is extremely high, and specific power becomes the dominant concern, with efficiency of little importance. This makes thin film cells a very attractive option. Figure 6 shows an artist's conception of astronaut unrolling a thin-film solar array to provide power for a manned base on the surface of Mars.

For a long-term manned lunar base, transportation costs are moderately high. However, the mass of the solar array for a lunar base is negligible compared to the storage capacity required for the 14 day lunar night, so specific power of the array is not an issue. Important uses for thin film cells may be for intermediate (14 day) stay-time missions where the array is brought with the spacecraft, and for manufacturing power, *e.g.*, lunar oxygen extraction, that require large amounts of power but could be run only during the sunlit periods.

Another option is a base at or near the lunar poles, which may be able to place a solar array to receive continuous sunlight [ref. 46]. For such a base the high specific power of thin-film cells could be very important.

In the long term, it may be economically feasible to manufacture solar cells on the moon from available lunar materials. In this case, the only practical cell material

is silicon, and the much smaller materials requirement for amorphous cells makes this the preferred technology. This is discussed in more detail by Landis and Perino [ref. 47].

Finally, it should be noted that in general, thin-film materials are tested at room temperature. Operating temperatures for surface power use, however, will vary considerably. On the moon, for example, peak operating temperatures may be as high as 90°C [ref. 48]; while on Mars, the operating temperatures may be as low as -100°C. Thermal cycling stresses are also likely to be considerably greater in many space applications, including both greater temperature changes and more rapid rates of heating and cooling. These issues will have to be addressed and cells and arrays will have to be designed and tested to function in the appropriate space environment.

Conclusions

Thin-film solar cells show a potential for making extremely lightweight solar arrays. Research programs for terrestrial photovoltaic power have resulted in dramatic improvements in the state of the art performance for thin-film photovoltaic materials. These improvements necessitate a reassessment of the potential for thin-film materials to be used for space power applications. Cells which have demonstrated over 9% efficiency CuInSe_2 and Cu(In,Ga)Se_2 , CdTe, and amorphous silicon. While the efficiencies are low compared to current technology space cells, the projected specific power levels are still extremely good. Development of multibandgap cascades raises the possibility that the efficiencies can be considerably improved.

Ultra lightweight space arrays will require that the materials can be deposited on thin, space-qualified materials. This issue is not being addressed in current research programs.

Data gathered to date [32] indicates that the radiation tolerance of such thin-film materials is equal to or better than any other known photovoltaic materials. While much of the radiation data is preliminary or incomplete, it appears that in some high radiation orbits, thin film materials may be the preferred technology even at present efficiency and specific power levels.

Data on the behavior of these devices in space is scanty. Even the efficiency information is extrapolated from terrestrial measurements, and needs to be verified in a rigorous manner using a spectrum calibrated for the specific material.

For several missions, including solar-electric propulsion, a manned Mars mission, and lunar exploration and manufacturing, thin film photovoltaic arrays may be a mission-enabling technology.

In order to take advantage of advances produced by existing terrestrial research programs, it is important that space power research programs focus attention on the issues not being addressed by research programs aimed at terrestrial power: weight,

radiation tolerance, AM0 calibration and measurement, space qualification of cells and arrays, and design of lightweight arrays for space and surface power use. Specific recommendations are:

(1) Thin film solar cells are inherently flexible and light weight. However, existing research programs are focussed on low cost (but not low weight) rigid substrates. *It is of critical importance that we stimulate interest in deposition on light-weight, space-qualifiable materials.* If this is not done, the entire thin-film research program is useless for space.

(2) Thin-film materials appear to be inherently highly radiation tolerant. However, preliminary results on radiation tolerance must be verified and continuing tests made that radiation tolerance remains high on new cell designs and emerging technologies and materials.

(3) Thin-film solar cells are currently tested almost exclusively under terrestrial (AM1.5) conditions. Calibration standards for space (AM0) measurement do not currently exist.

(4) The road to full space qualification is long and slow. It is important that we continually verify performance in space on each emerging technology in order for us to have sufficient confidence in the materials to rely on them when critical space and surface power requirements come on line in the early decades of the next century. Required tests include not only space demonstrations, but tests of the cells under thermal extremes and thermal cycling conditions characteristic of the environments they will be needed in.

(5) Thin-film cells for space and surface power use will require unique light-weight array designs with structural mass reduction comparable to the reductions in mass per unit area of thin-film cells. It may not be too early to begin considering how such arrays should be designed.

Acknowledgement

I would like to thank Ken Zweibel of SERI (whose review article on the use of thin-film cells for space [ref. 37] is recommended) for helpful discussions, and Kim Mitchell of ARCO Solar for providing several of the figures used here. This paper is based in part on an earlier review of thin film solar cell technology for space presented at the IAF International Conference on Space Power, Cleveland, Ohio, in June 1989.

References

- [1.] D. J. Flood and H. Brandhorst Jr., *Current Topics in Photovoltaics*, **2**, 1988.
- [2.] S. P. Tobin *et al.*, *4th International Photovoltaic Science and Engineering Conference*, Sydney Australia, 14, 1989.
- [3.] S. Ochi *et al.*, *Tech Digest of the International PVSEC-3*, Tokyo, Japan 755, 1987.
- [4.] S. P. Tobin *et al.*, *IEEE Electron Dev. Lett*, EDL-9(5) 256.
- [5.] S. P. Tobin *et al.*, *20th IEEE Photovoltaic Specialists Conference*, 405, 1988.
- [6.] R. E. Hart, Jr., D. J. Brinker, and K. A. Emery, *20th IEEE Photovoltaic Specialists Conference*, 764, 1988.
- [7.] G. A. Landis, *20th IEEE Photovoltaic Specialists Conference*, 708, 1988.
- [8.] C. J. Keavney and M. B. Spitzer, *Appl. Phys. Lett.* **52**, 1439, 1988.
- [9.] I. Weinberg, C. K. Schwartz, and R.E. Hart Jr., *Space Photovoltaic Research and Technology Conference*, NASA Lewis Research Center, 17, 1988.
- [10.] J. J. Loferski, *J. Appl. Phys.* **27**, 777, 1956; reprinted in *Solar Cells*, C.E. Backus, ed, 89, IEEE Press, NY 1976.
- [11.] J. J. Hanek *et al.*, *1986 Space Photovoltaic Research and Technology*, NASA CP 2475, 99.
- [12.] J. Severns *et al.*, *20th IEEE Photovoltaic Specialists Conference*, 801, 1988.
- [13.] R. Hill and J. D. Meakin, in *Current Topics In Photovoltaics*, Volume 1, (T.J. Coutts and J.D. Meakin, eds), 223, Academic Press, Inc., 1985.
- [14.] A. L. Fahrenbruch and R. H. Bube, *Fundamentals of Solar Cells*, 418, Academic Press, NY, 1983.
- [15.] A. M. Barnett, *2nd EC Photovoltaic Solar Energy Conference*, 328, 1979.
- [16.] L. L. Kazmerski and S. Wagner, in *Current Topics In Photovoltaics*, Volume 1, (T. J. Coutts and J. D. Meakin, eds), 41, Academic Press, Inc., 1985.
- [17.] K. W. Mitchell *et al.*, *20th IEEE Photovoltaic Specialists Conference*, 1384, 1988.
- [18.] K. W. Mitchell *et al.*, *4th International Photovoltaic Science and Engineering Conference*, Sydney Australia, 1989.

- [19.] W. S. Chen *et al.*, *19th IEEE Photovoltaic Specialists Conference*, 1445, 1987.
- [20.] R. Noufi *et al.*, *Solar Cells*, **17**, 303, 1987.
- [21.] W.E. Devaney *et al.*, *IEEE Trans. Electron Dev.*, **37**:2, 428-433, 1990.
- [22.] K. Zweibel, H.S. Ullal, and R.L. Mitchell, *20th IEEE Photovoltaic Specialists Conference*, 1469, 1988.
- [23.] K. W. Mitchell, G.A. Pollock, and A.V. Mason, *20th IEEE Photovoltaic Specialists Conference*, 1542, 1988.
- [24.] P. V. Meyers, *7th European PV Conference*.
- [25.] A. Rohatgi *et al.*, *20th IEEE Photovoltaic Specialists Conference*, 1477, 1988.
- [26.] B. M. Basol and E.S. Tseng, *Appl. Phys. Lett* **48**, 946, 1986.
- [27.] H. Richter, *20th IEEE Photovoltaic Specialists Conference*, 1537, 1988.
- [28.] W. Wallace *et al.*, *19th IEEE Photovoltaic Specialists Conference*, 593, 1987.
- [29.] N. Nakatani *et al.*, *4th International Photovoltaic Science and Engineering Conference*, Sydney, NSW Australia, Vol. 2, 639, 1989.
- [30.] J. H. Hanak *et al.*, *Space Photovoltaic Research and Technology*, 176, 1988..
- [31.] A. M. Barnett *et al.*, *4th International Photovoltaic Science and Engineering Conference*, Sydney, NSW Australia, Vol. 1, 151, 1989.
- [32.] J. Woodyard and G.A. Landis, "Radiation Tolerance of Thin Film Solar Cells," (to be published) *Solar Cells*, 1990.
- [33.] H.W. Brandhorst, Jr. and R.E. Hart, *4th Photovoltaic Specialists Conference, Volume II*, A7-1, 1964.
- [34.] D.J. Curtin, *7th Photovoltaic Specialists Conference*, 206, 1968.
- [35.] C. F. Gay *et al.*, *17th IEEE Photovoltaic Specialists Conference*, 151, 1984.
- [36.] R. M. Burgess *et al.*, *20th IEEE Photovoltaic Specialists Conference*, 909, 1988.
- [37.] K. Zweibel, *23rd Intersociety Energy Conversion Engineering Conference*, July 31-August 5 1988, Denver, CO.
- [38.] J. Bernard *et al.*, *Cellules Solaires*, Gordan and Breach, 229, July 1970.

- [39.] C. E. Byvik *et al.*, *17th IEEE Photovoltaic Specialists Conference*, 155, 1984.
- [40.] G. A. Landis, *Solar Cells* **15**, 203, 1988.
- [41.] J. C. C. Fan, B-Y Tsaun, and B. J. Palm, *16th IEEE Photovoltaic Specialists Conference*, 692, 1982.
- [42.] K. Mitchell, C. Eberspacher, J. Ermer and D. Pier, *20th IEEE Photovoltaic Specialists Conference* 1384, 1988.
- [43.] P. V. Meyers *et al.*, *20th IEEE Photovoltaic Specialists Conference*, 1448, 1988.
- [44.] H. Richter, *20th IEEE Photovoltaic Specialists Conference*, 1537, 1988.
- [45.] R. W. Francis, D. J. Flood, and W. A. Somerville, *20th IEEE Photovoltaic Specialists Conference*, 8, 1988.
- [46.] J. D. Burke, in *Lunar Bases and Space Activities of the 21st Century*, W. W. Mendell, ed., 77, Lunar and Planetary Institute 1985.
- [47.] G. A. Landis and M.A. Perino, 9th Biennial Princeton/SSI Conf. Space Industrialization, 1989; printed in *Space Manufacturing* **7**, 144, AIAA, 1989.
- [48.] G.A. Landis, S.G. Bailey, D.J. Brinker, and D.J. Flood, *40th IAF Congress*, Malaga, Spain, Oct. 1989. To be published, *Acta Astronautica*, **22**, 1990.
- [49.] J. Appelbaum and G.A. Landis, *10th Space Photovoltaic Research and Technology Conference*, Cleveland, OH, Nov. 1989.

TABLE I. - HISTORICAL PROGRESS OF THIN-FILM
SOLAR CELL EFFICIENCY

[Experimentally achieved efficiencies (at Air Mass Zero, in percent) as of 1978, 1983, 1988, and projected values for future performance.]

Material	1978	1982	1988	1990's
CdS/Cu ₂ S	7.3	8.2	9.	10.0
CuInSe ₂	5.3	8.5	11.2	12
CuGaSe ₂	---	---	4.6	12.5
CuInS ₂	2.9	2.9	6.1	12.5
CdTe	4.1	8.4	8.6	12.5
a-Si	4.4	8.1	9.0	11.5

note added in proof: CdTe cells developed by Photon Energy Co. have since reached efficiency of 9.8 % AM0.

TABLE II. - PROJECTIONS FOR FUTURE EFFICIENCY
[In percent.]

Material	Current	Future	
		Conservative	Optimistic
Si	18	19.5	22
GaAs	21.4	22	25
CuInSe ₂	11.2	12	13
Opt. thin-film	8.6	12.5	15
Thin-film Cascade	12.5	18	20

TABLE III. - PROJECTIONS FOR SPECIFIC POWER
[Does not include coverglass.]

Material	Thickness, μm	Substrate, μm	Current, kW/kg	Future	
				Conservative, kW/kg	Optimistic, kW/kg
Si	60	-	1.8	1.9	2.2
GaAs	60	-	0.9	0.9	1.0
CuInSe ₂	3	6	7.0	7.5	8.1
Opt. thin-film	3	6	5.3	7.8	9.4
Thin-film cascade	6	6	3.9	5.6	6.2

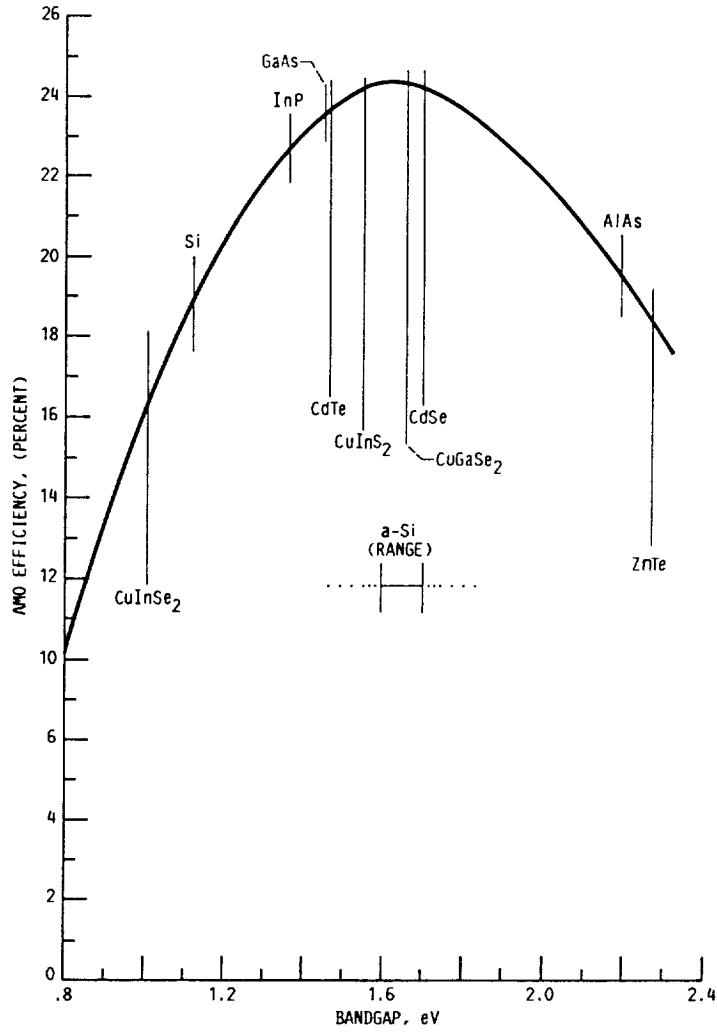

1. Achievable Efficiency for a Single Junction Solar Cell as a Function of the Bandgap of the Material.

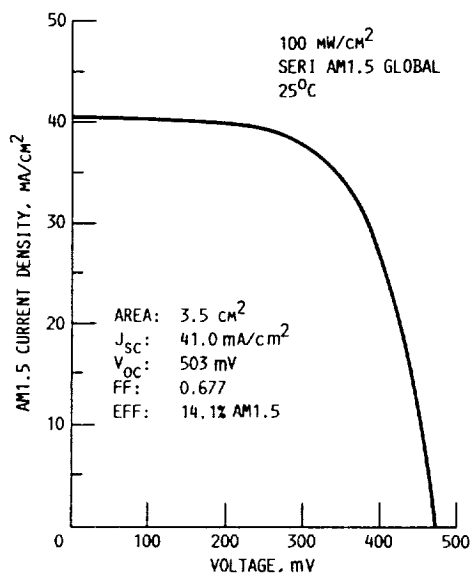

(a) CURRENT VERSUS VOLTAGE MEASURED AT AIR MASS 1.5.

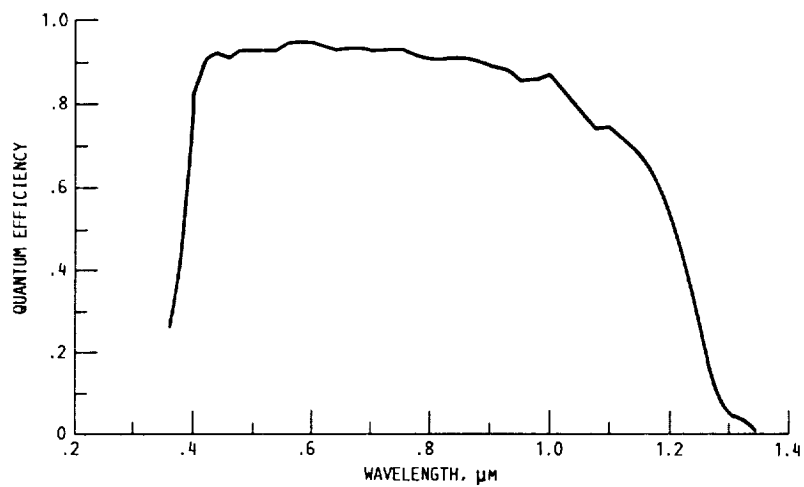

(b) QUANTUM EFFICIENCY VERSUS WAVELENGTH.

2. Electrical Characteristics of ARCO-Solar High-efficiency ZnO/CdS/Copper Indium Selenide Solar Cell.

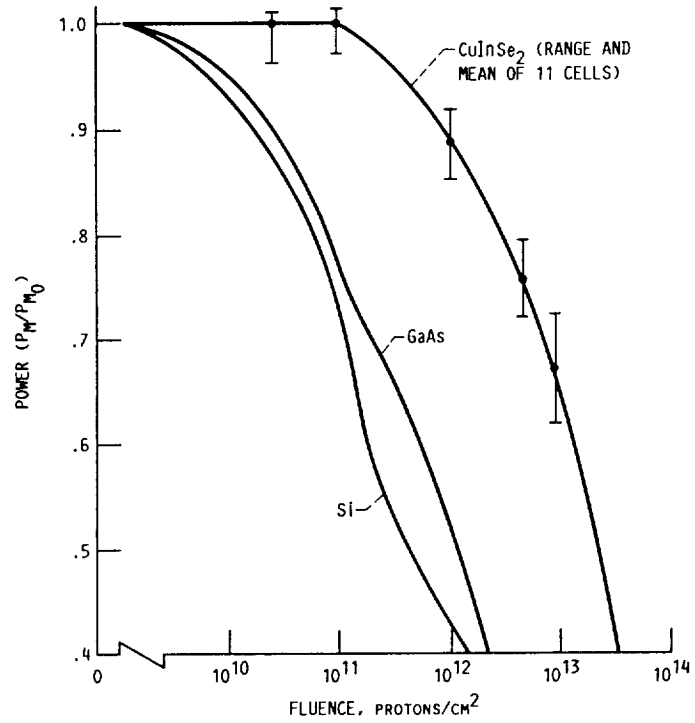

3. Effect of 1-Me Proton Irradiation on the Maximum Power of Silicon, Gallium Arsenid, and Copper Indium Selenide Solar Cells.

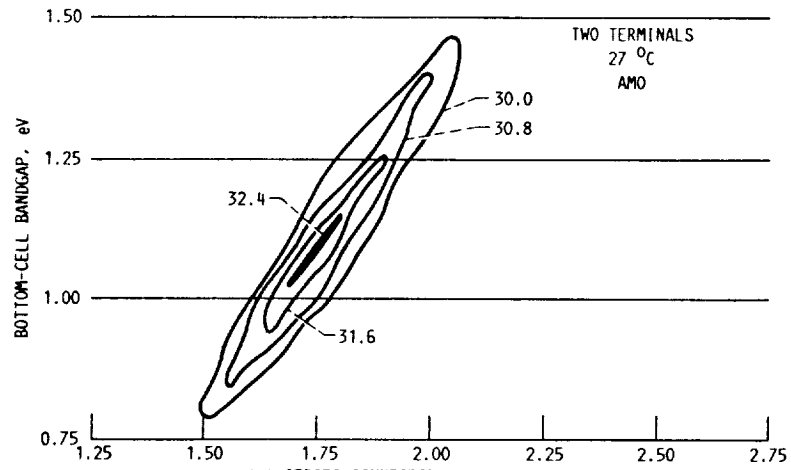

(a) SERIES CONNECTED (CURRENT MATCHED).

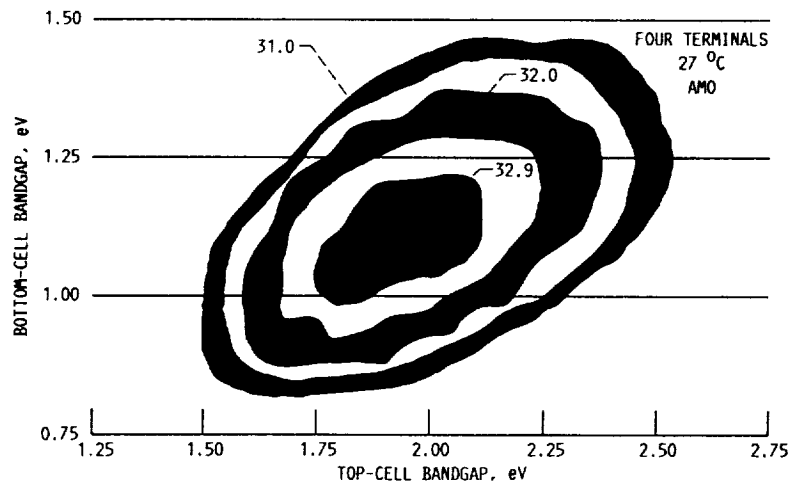

(b) INDEPENDENT ELEMENTS.

4. Maximum Theoretical Efficiency of a Solar Cell Cascade as a Function of the Bandgaps of the Top and Bottom Cell Material

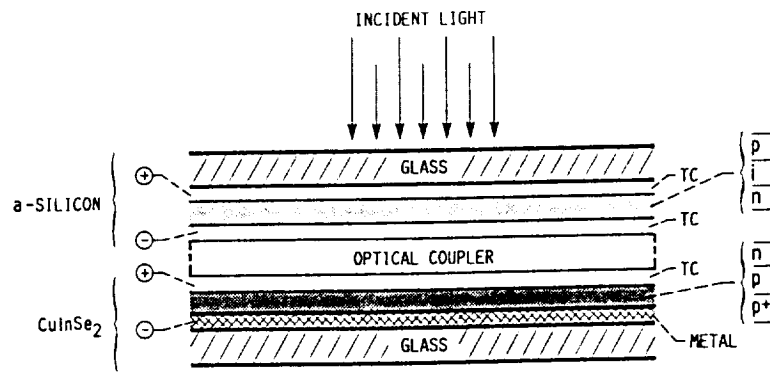

(a) CROSS SECTION.

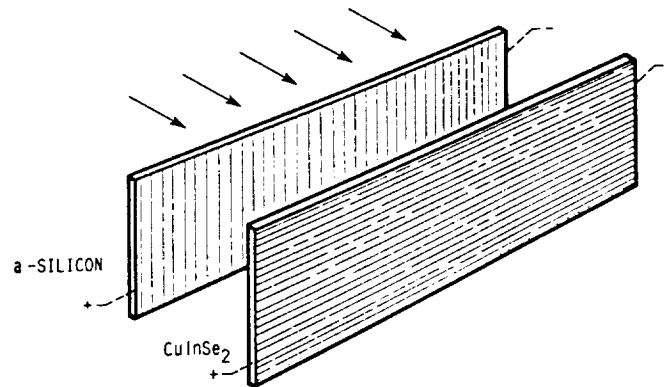

(b) CASCADE CONFIGURATION.

5. ARCO Soar Tandem module

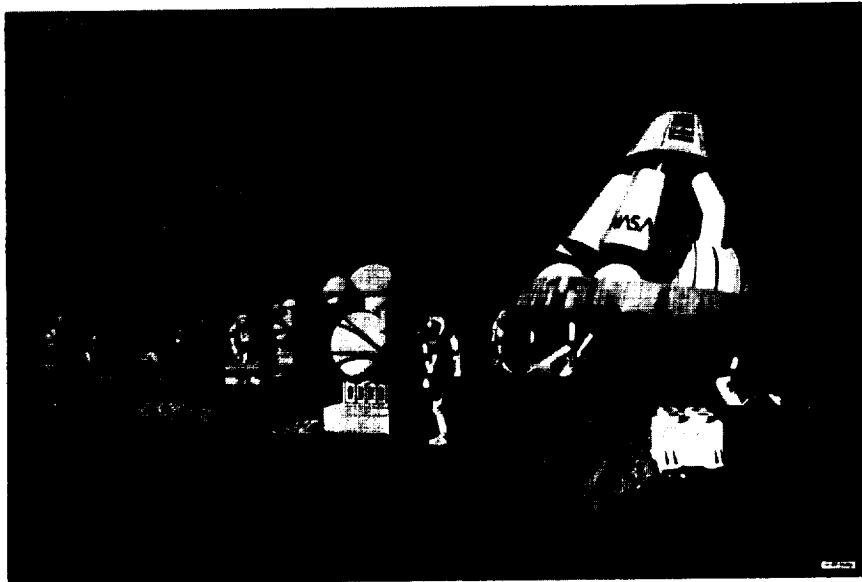

Artist's Conception of Power System for a Manned Mars Base.