

# Review on Fault Current Limiters

Sushma Yadav

Dept. of Electrical Engineering,  
National Institute of Technology,  
Patna-800005, India

Dr. G K Choudhary

Dept of Electrical Engineering  
National Institute of Technology,  
Patna-800005, India

Rajib Kumar Mandal

Dept. of Electrical Engineering  
National Institute of Technology,  
Patna-800005, India

**Abstract**—The demand for electricity is increasing at a very high rate and demand for power is running ahead of supply. Introduction of Distributed energy resources (DES) is the biggest change happening to the distribution network. There is an increased integration of DES with the distribution network using power electronics converters as to meet the continuously increasing demand of electricity. In future it is expected that the penetration level of distributed energy resources will further increase. The connection of distributed energy resources with the distribution network result in increase in the value of fault current which can causes the abnormal conditions in the entire power system network . The equipment installed at generating station and at substation is very expensive. Therefore it is necessary to protect these equipment from fault current. A Fault Current Limiter (FCL) is a revolutionary power system device that overcomes the problems due to increased fault current levels. It is a device that reduces prospective fault currents to a lower manageable level. In this paper principals of operation and structures of various fault current limiter is discussed. It gives short and up-to-date literature review of conventional fault current limiting devices as well as fault current limiting devices which are still in a research or development stage.

**Keywords**— distributed Energy Resources; fault current; fault current limiter (FCL); power system network

## I. INTRODUCTION

The electricity requirement of the world including India is increasing at high rate and power demand has been running ahead of the supply due to population growth, bigger houses, bigger TVs, more air conditioners and more computers. Our nation's electric power infrastructure that has served us so well for so long – also known as “the grid” –is rapidly running up against its limitations. It will not be able to meet our future power demand. Our country's electricity is still produced by burning coal and a rich domestic resource which contribute to global warming. We need a grid which produces electricity that is cleaner, reliable, efficient and responsive than conventional power grid. If we are to reduce our carbon footprint and global warming renewable sources of energy like solar, wind and geothermal must be integrated into the nation's grid. These are called distributed energy resources and production of electricity by using these resources is called distributed generation. Distributed generation is the use of small-scale power generation technologies located close to the load being served, capable of lowering costs, improving reliability, reducing emissions and expanding energy options.

The electric industry is required to make the transformation from a centralized, producer-controlled network to one that is less centralized and more consumer-interactive. It will provides consumers with the ability to use electricity more efficiently and provides utilities with the ability to detect problems on their systems and operate them more efficiently. In the coming future there will be increased penetration of distributed energy resources with the distribution network using power electronic converters to meet the continuously increasing power demand. Hence in the future power grid some of the energy-demand is supplied by the centralized generation and another part is produced by distributed generation. Public concerns about climate change have resulted in a large interest in the use of renewable energy and the efficient use of cheap fuel alternatives.

The connection of DG to the power system will improve the voltage profile, power quality and support voltage stability. Therefore, the system can withstand higher loading situations. It will reduce our dependence on fossil fuel, reduce large blackout, improve reliability and security of supply etc. But there are also many negative impact on the system caused by these penetration of a DG into an existing distribution system, with increase in the value of fault current being one of the major issues[1]. Fault current are the transient current that flows through an electrical power system when a short circuit occur. The equipment installed at power station and at generating station is very expensive and costly. Therefore it is necessary to save these equipment from fault current. From both technical and economical points of view, a device that reduces the short circuit current is needed. This paper present up-to-date literature study of a wide variety of the FCL(s) that have been researched, prototyped and field tested .Concepts, principles, Advantages and disadvantages and comparison of various potential FCLs are also discussed .

## II. CONVENTINAL METHODS FOR FAULT CURRENT PROTECTION

The most common ways of handling these fault current are by using air core reactor, Fuses and Circuit Breakers. Air core reactor although commonly used but are undesirable because it causes continuous voltage drop and power loss during normal system operation. A fuse is a simple, cheap, rugged, small size, and reliable protective device that can be used to handle fault currents as high as 200 kA. Fuses are also undesirable because the entire portion of the system protected

by fuse is shut down on the occurrence of fault and it is required to replace fuse manually after every use. The problem with circuit breakers is that it allows first few cycle of the fault current to pass through it before operating. The future concern is that the expected fault current levels may exceed the interrupting capability of existing CBs. Failure of protection equipment to interrupt the fault current may cause extensive damages and put at risk the reliability and stability of the power system. The existing protection devices will become underrated for the increased value of fault current so we cannot use the conventional lower rated protection devices. The other common ways to limit fault current are splitting of power grid after fault occurrence, multi-bus running and using complex strategies like sequential network tripping. However, these alternatives may create other problems such as loss of power system safety and reliability, high cost and increasing power losses [2].

Now the Solutions is either to upgrade the substation to cope with the new maximum short circuit current – from mechanical and thermal point of view. This will require huge investment or , add a device which reduces the short circuit current to a value which our existing substations can easily handle. Fault Current Limiters have the potential to limit fault currents and to enhance system stability. Fault current limiters (FCL) reduce the fault current and make possible the use of lower rated protective devices [3]-[4].

### III. FAULT CURRENT LIMITERS

A Fault Current Limiter (FCL) is a device which limits the prospective fault current when a fault occurs in the power system. It reduces fault currents to a lower manageable level and make possible the use of lower rated protective devices. Recent trend of deregulation and restructuring of the power grid has invoked a renewed interest in FCL technologies for implementation of reliable and economically feasible commercial devices [5]. Various types of fault current limiters have been developed recently.

### IV. BENEFITS OF FAULT CURRENT LIMITERS

The primary benefit of fault current limiter is in saving the cost of removing lower rated and installing higher rated equipment in existing installations since it reduces the value of fault current which the existing protection device can handle. FCL's are installed in each phase of the line, and it insert a series impedance to limit the fault current to an acceptable value . FCL's reduce the short circuit level, hence providing more secure system operation. With these devices installed in the circuit, parallel paths could be tied together to enhance reliability without any concern for the increment in the total short circuit level. Reduced or eliminated wide-area blackouts, reduced localized disruptions, and increased recovery time when disruptions do occur.

### V. IDEAL FAULT CURRENT LIMITER

- An Ideal fault current limiter should posses following properties:-
- Invisible during normal system operation i.e insert zero impedance in the system when there is no fault in the system.

- Insert large impedance when fault occur in the system.
- Operate within the first cycle of the fault current .
- It should have short time recovery i.e. it return to its normal operation within short interval after limiting the value of the fault current.
- It should operate and return back to its normal state automatically.
- Capable of repeated system operation and should have long life.
- It should not affect relay coordination.
- It should be of small size and cost effective.

### VI. THREE MAJOR TECHNOLOGY DEVELOPMENTS THAT ENHANCES THE INCREASE IN FCL ACTIVITIES:

- Refinement of production process of YBCO based superconductors for coated conductors (2G wire) with sufficient yield at acceptable cost (or at least cost projections)
- Progress in development of Magnesium Diboride (MgB<sub>2</sub>) superconductors wire designed specifically with FCL properties
- Progress in development of Silicon Carbide (SiC) power electronic devices

### VII. CLASSIFICATION OF FAULT CURRENT LIMITERS

Even though there is not a general specification for a fault current limiter, the FCL's can be classified as :-

- Pyrotechnic fault current limiters (Is-limiter),
- Fault current limiting reactor,
- Superconducting FCL (SFCL),
- Solid-State FCL (SSFC),
- Electromagnetic FCL
- Hybrid FCL

Pyrotechnic fault current limiters (Is-limiter) and Fault current limiting reactor are conventional fault current limiter and are commercially available in the market whereas SFCL, SSFCL, Electromagnetic FCL and Hybrid FCL are Novel FCLs and they are in Research & Development stage.

#### A. Fault current limiting reactor

Fault Current Limiting reactors are coils used to limit current during fault condition. It is widely used for the fault current limiting in medium and low voltage distribution system, and is the most mature and simplest type of the fault current limiter. Such reactors have large value of inductive reactance and low ohmic resistances.

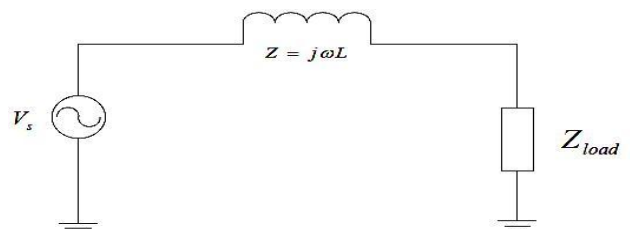

Fig. 1. Fault current limiting reactor

The current limiting strategy is achieved by inserting impedance  $Z = j\omega L$ . For current limiting reactor, it is important that magnetic saturation at high does not reduce the coil reactance. It is generally of two types air cored type or iron cored type. Air cored reactor does not suffer from magnetic saturation and therefore their reactance is independent of current. For this reason air cored reactors are commonly used.

- 1) Externally triggered
- 2) Non-Resettable

### C. Superconducting Fault Current Limiters

Superconducting Fault Current Limiter (SFCL) is a novel electric equipment which has the capability to reduce the fault current level within the first cycle of fault current. It uses the properties of superconductor to reduce the value of the fault current. Superconductor materials lose their electrical resistance below certain critical values of temperature, magnetic field, and current density. Below these critical value it has negligible impedance and it is said to be in its superconducting mode and above these critical value it has high impedance and said to be in its current limiting mode. Increasing any of these three parameters above their critical value causes the material to quench i.e. switch from its superconducting mode to its high resistance mode. Superconducting fault current utilizes variable impedance which is connected in series with the electrical system that varies depending on operating conditions. When faults occur, the impedance rises to a value where fault current is correspondingly reduced to a lower level which the circuit breaker can handle [7].

Superconductors are of two types-Low temperature and High temperature superconductors. Low temperature superconductors (LTS) are first generation superconductors and these "classical" metallic superconductors have transition temperatures below 25 K. Due to the low operating temperature (usually the material is cooled using liquid helium to 4.2 K), the cooling costs are extremely high and fault current limiters based on LTS are not expected to be commercialised. In 1986 a new class of superconductors was discovered. Their relatively high transition temperatures led to the name high temperature superconductors (HTS). High temperature superconductors (HTS) are ceramic materials and are second generation superconductors. Practical HTS's have critical temperatures up to 110 K. Limiters utilizing high-temperature superconductors are usually cooled with liquid nitrogen and operating at 77 K [8]. Since the advent of commercial second generation (2G) high temperature superconductor wires (HTS), a cost-effective commercial design is becoming feasible. YBCO (Yttrium-Barium-Copper-Oxide) coated conductors have become significantly important for novel SCFCL designs. The principle advantage of using high temperature superconductors is an economic one with reduced refrigeration capital costs and, more importantly, running costs [9].

Magnesium Diboride ( $MgB_2$ ) has also emerged as a suitable candidate material for FCL devices. The major advantages of this material is its inexpensiveness, hence utilizing  $MgB_2$  is expected to reduce the cost for superconducting material used in the SCFCL. Superconducting fault current limiter (SFCL) is an ideal current limiter, but it is still only in the researching stage. The technical performance of superconducting fault current limiters has been demonstrated by numerous successful projects worldwide.

Superconducting fault current limiters are basically of two types:

#### Advantages of Fault Current Limiting Reactors

- 1) Simple construction
- 2) Require less maintenance
- 3) Low cost

#### Disadvantages of Fault Current Limiting Reactors

- 1) It introduces impedance in the system that is present at all the times in the system which causes permanent voltage drop and losses in the system and therefore affects voltage regulation and reduces efficiency of the system during normal system operation.
- 2) It causes lagging power factors
- 3) Bulky to handle and replace

### B. Pyrotechnic fault current limiters (Is-limiter)

The Is-Limiter consists of extremely fast switch which is capable of carrying a high rated current but incapable of limiting fault current. A high rupturing capacity fuse arranged in parallel. The switch is connected in series with the main conductor, an external trigger is required to open it when fault occur in the system. When the main conductor is opened, the current start flowing through the parallel fuse, where it is limited within 0.5 ms and then finally interrupted at the next voltage zero passage [6]. The current flowing through the Is-Limiter is monitored by an electronic measuring and tripping device. At the very first rise of a fault current, this device decides whether tripping of the Is-Limiter is necessary. In order to reach this decision, the instantaneous current and rate of current rise at the Is-Limiter are constantly measured and evaluated.

When the set points are simultaneously reached or exceeded, the Is-Limiter trips in the faulty phases. After operation the limiter has to be disconnected by a series-connected circuit-breaker in order to get access for changing the tripped Is-Limiter. The invention of the Is-Limiter was done in 1955 therefore several thousand devices have been successfully used in DC, AC and particularly in three phase system.

#### Advantages of Pyrotechnic fault current limiters (Is-limiter)

- 1) Generator can be connected independent on the short-circuit capability of the system.
- 2) Only IS -limiters close to fault location trip
- 3) Existing busbar and cable systems have not to be changed.

#### Disadvantages of Pyrotechnic Fault Current Limiters (Is-limiter)

- 1) Resistive type SFCL
- 2) Inductive type SFCL
  - a) Shielded iron-core type SFCL
  - b) Saturated iron-core type SFCL

Both have been subject to tests on electrical networks

### 1) Resistive type SFCL

The resistive type is a superconducting element connected in series with the network. It is the simplest type of SFCL. It can be just only a low temperature superconducting wire or a certain length of high temperature superconductors. When the current is normal, the superconductor is in the superconducting state without resistance. If the current increases over the critical current, the superconductor goes into its normal state and it has a high resistance connected in series with the network. This resistance will limit the current. A parallel resistance is required to be connected with the superconducting element.

The parallel resistance or inductive shunt is needed to avoid hot spots during quench, to adjust the limiting current and to avoid over-voltages due to the fast current limitations. The resistive SFCLs are much smaller and lighter than the inductive ones [10]. First commercial resistive FCL has been energized in late 2009 in Europe [11]. Currently, two parallel projects in US aiming to build transmission voltage level resistive FCL are undergoing [12],[13].

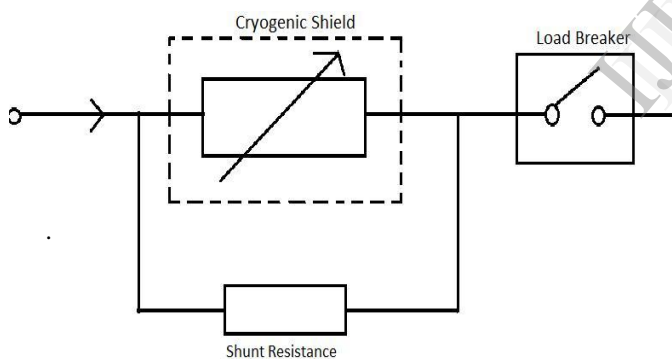

Fig.2. Resistive type SFCL

superconducting wires for fault current limiter applications.” In the recent decades the price of the YBCO coated conductor drops significantly and the performance has improved, therefore, it has gained significant attentions as the superconducting material for resistive type FCL and the research on it has been carried out worldwide. In October 2011, a 138 kV, 0.9 kA resistive SFCL was successfully tested in a high-voltage transmission grid [14]. The tested system proved to reduce fault current levels by more than 50 percent.

### 2 ) Inductive type SFCLs

The inductive type is a special transformer connected in series with the network. This transformer has a conventional primary coil, and a rather special secondary “coil”: a superconductor ring. When the current is normal, the

superconductor ring gives a deexcitation. In normal operation the primary winding resistance and leakage inductance determine the impedance of the limiter. Thus during normal operating condition the FCL exhibits a low impedance (approximately the leakage reactance). When the current increases over the critical current, the superconductor ring goes into normal state. In this case the FCL represents high impedance (approximately the main field reactance).

#### a) Inductive Shielded Superconducting Fault Current Limiter

This device is based on the principle of perfect diamagnetism of the superconductor, that is in superconducting state the magnetic field is expelled from the superconductor. This effect was first discovered by Meißner and Ochsenfeld. It works like transformer, the superconducting element is a cylinder which forms the single turn short circuited secondary of an iron cored transformer which has part of the power line as its primary. In its superconducting state, this cylinder effectively screens the iron core from the primary, and a low inductance (i.e. impedance) is introduced in the line. However, when the current (and hence the magnetic field) increases above a certain level, the superconductor can no longer shield the iron core), flux enters the iron and a high impedance is inserted in the line which is to be protected.

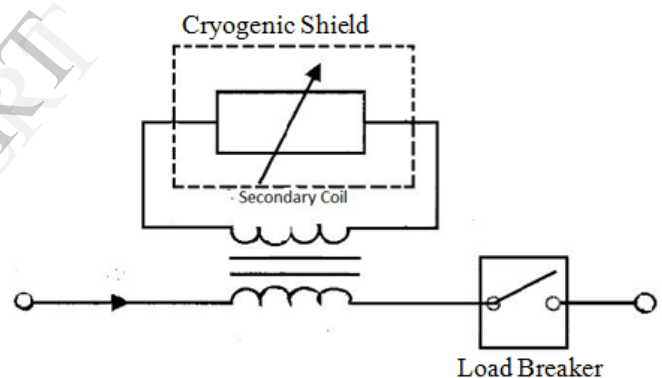

Fig.3. Inductive Shielded Superconducting Fault Current Limiter

The primary winding acting as the main current lead of the circuit is built in a way not to be exposed to the cryogenic part but to the temperature level of the environment. In normal operation the magnetic field is expelled from the superconductor. That means that the magnetic flux, generated by the primary winding, is not able to penetrate the iron core. Therefore the iron core doesn't cause any magnetization losses and the limiter inserts very low impedance to the network. Only in the resistive state when the superconductor is no longer able to expel the magnetic field, large impedance is inserted into the network.

The secondary winding is divided into two parts, the superconductive winding and its normal conductive bypass. As the superconductor is based on an YBCO ceramic, changing from superconductive to normal state would dissipate so much energy into the ceramic material that it would be destroyed. Therefore a bypass coil is taking over the current flowing in the normal state. As long as the critical current of the superconductor is not reached, the



secondary winding blocks the magnetic flux in the iron core. In case of a failure current the dissipated current into the secondary winding becomes much high that the superconducting state will be broken. The voltage induced in the secondary by-pass winding by coupling of the iron core will cause the counter induction to reduce the current in the primary coil. The prospect of this type of limiter to be economically competitive is very low however there are still a few small, mostly university based academic projects active that utilize the “shielded core” type [15].

#### b) Saturated iron-core type SFCL.

In the saturated-core FCL, two iron cores (one for each half of the cycle) are saturated by the dc magnetic field produced by a superconducting coil wrapped around each core. The main power line is wound around both cores and, when the current becomes high enough (i.e. a fault) the cores are driven out of saturation and the impedance rises - limiting the current.

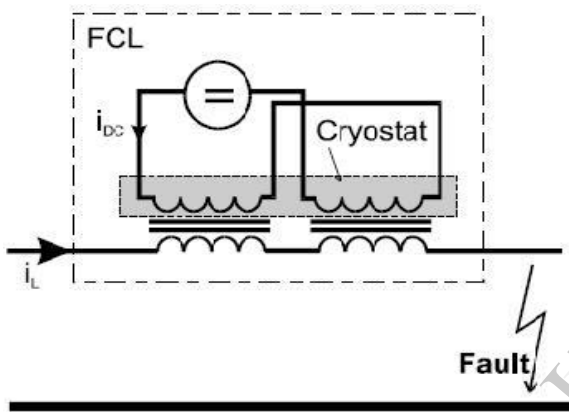

Fig.4. Saturated iron-core type SFCL

Fig.4, above shows a structure diagram of single-phase magnetic saturated core type SFCL, which is composed by iron cores, AC windings, superconducting DC winding, DC power and the control circuit. Under the normal operating condition, DC superconducting coil generate a lot of magnetic flux which can make the core saturated. Therefore it offers very small impedance to the power system which has no adverse effect on normal transmission.

When the short circuit fault occurs, the current surges, and fault monitoring system will instantly cut off the DC exciting-current within a few milliseconds by means of power electronic switch, such as insulated gate bipolar transistor (IGBT) or integrated gate commutated thyristor (IGCT), in the DC control circuit. Then both of the two cores go out of deep saturation status so that fault current in the two AC winding will produce large inductive EMF which can limit fault current. The advantage of this concept is that it does not require the superconductor to become normal to operate. However, it requires approximately twice as much iron (*two* cores). This system doesn't use the special properties a superconductive material has and theoretically it could be built without using superconductive conductors. In 2009, a saturated iron-core SFCL device was experimentally tested in

small-scale distribution networks in California, United States [16]. In January 2010, the test field in California suffered a lightning-induced fault and the FCL device limited the fault current as designed. A field test in a 138 kV transmission network was planned for the end of 2011 [16].

#### Advantages of Superconducting FCL

- 1) Rapid Response
- 2) No external control is needed.
- 3) Negligible loss during normal system operation.

#### Disadvantages of Superconducting FCL

- 1) One current disadvantage is that there is energy loss caused by the current leads passing from room temperature to cryogenic temperature that will result in a loss of approximately 40-50 W/kA heat loss per current lead at cold temperature.
- 2) Requires cooling which result in increase in its cost.
- 3) Superconductors tend to the development of thermal instabilities (the so called hot spots). In order to protect the materials against these hot spots often a normal conducting bypass is employed.

#### D. Solid State Fault Current Limiters

Solid-state fault current limiters consist of semiconductor devices which are able to interrupt a fault current during its rise before the peak value is reached. It is a advanced current interruption technology which offers a viable solution against fault current occur in the transmission and distribution system. Recent developments in power switching technology have made solid state limiters suitable for voltage and power levels necessary for distribution system applications. It utilizes semiconductor (solid state) switches as the non-linear elements causing the condition based increase in impedance during the fault. In particular the progress in development of Silicon Carbide (SiC) semiconductors as well as advances in Silicon (Si) based devices draws increase attention within the R&D community for utilization in FCL devices. Solid state limiters use a combination of inductors, capacitors and thyristors or gate turn off thyristors (GTO) to achieve fault limiting functionality.

It consists of solid state switch, current limiting impedance, voltage limiting element, a series circuit breaker, an overcurrent detector and a control device. The current limiting behavior of SSFCL is based on on/off status change of semiconductor switching devices. A current limiting impedance is connected in parallel with the solid state switch so that the current continue to flow, but at a limited level, after the solid state switch interrupts the fault current. Presently, two major SSFCL projects are led by EPRI [17]: one is based on silicon GTO; the other on SiC -GTO. Both are controlled by external signals. Arkansas Power Electronics International (APEI) at the University of Arkansas has successfully developed a low power solid state FCL (SSFCL) test unit using SiC devices. While the power rating is still small (approximately 1 kW) this project is worth noting since this is the first SiC based FCL of this kind. In 1992, Toshiba developed the 2kV/400A SSFCL with shunt reactor, which

can limit the steady-state short circuit current from 11 kA to 940 A in the 10 kV system.

#### Classification of Solid-State FCLs

- 1) Series switch type,
- 2) Bridge type and
- 3) Resonant type.

##### 1) Series switch type solid-state FCL

The series switch types FCLs are composed of bidirectional controlled switch and bypass circuit. The bidirectional switch may be implemented with various semiconductor devices. The bypass circuit contains normal state bypass, fault current bypass, over voltage protection bypass and a snubber. The normal state bypass usually is an electromechanical switch. Its purpose is to reduce the losses and distortion in the normal state. The fault current bypass restricts the fault current – some schemes turn off the switches to interrupt the current, other modulate the fault current to keep it within the acceptable limits. The fault-current bypass can be implemented with either a resistive or inductive components. While the normal-state and the fault-current bypasses are optional.

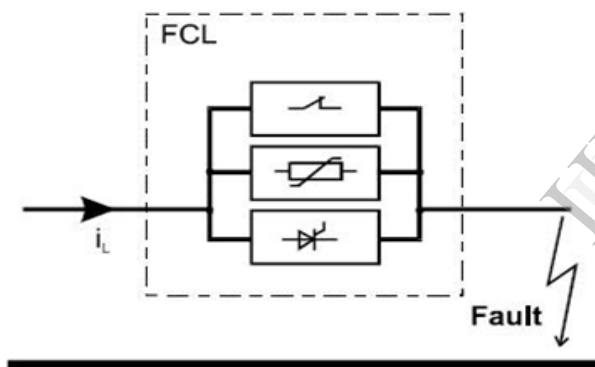

Fig.5. Series Switch-Type FCL [19]

The overvoltage bypass is usually implemented with a high voltage and high power ZnO varistors or arresters. The snubber are also essential, because they limit the voltage and  $dv/dt$  across the semiconductor switch and absorb some amount of the energy, stored in the line inductance respectively[18].

##### 2) Bridge type solid state fault current limiters

Bridge-type FCLs as shown in Fig.6, below are realized using a current fed full-bridge switch arrangement. This topology is inherently suited for using diodes as well as advanced thyristors as line commutated switches. Bridge-type FCLs do not have normal state bypass, may or may not have fault-current bypass, and do have overvoltage protection bypass. In the NS, all the bridge elements are “ON” providing unrestricted conduction path for ac line current. The bridge-type FCL current limiter operating principle relies on insertion of a dc current source in series with the line. Practical bridge-

type FCLs use reactors to emulate the current source action.

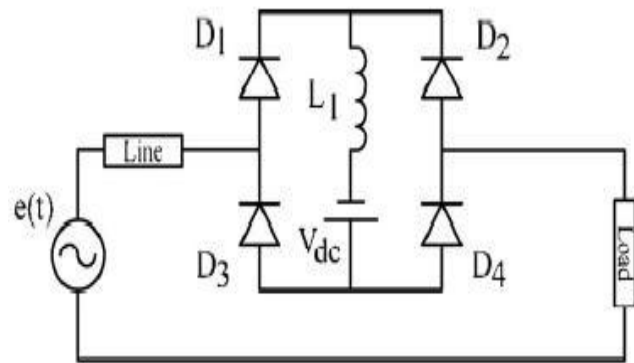

Fig.6. Bridge type solid state fault current limiter

In case the bridge is realized with thyristor controlled or semi controlled switches, ac current interruption or diversion to a fault-current bypass is possible [19].

##### 2) Resonant type FCL

The resonance types FCLs use switches to reconfigure their topologies either into the normal state or into the fault condition. They employ series resonant circuit tuned to the line frequency and thus present negligible impedance to the line. Under the fault conditions the circuit is switched to the fault state sub-topology and much higher impedance is presented to the line. The resonance FCLs reduce the fault current but they do not have interruption capability [20,21].

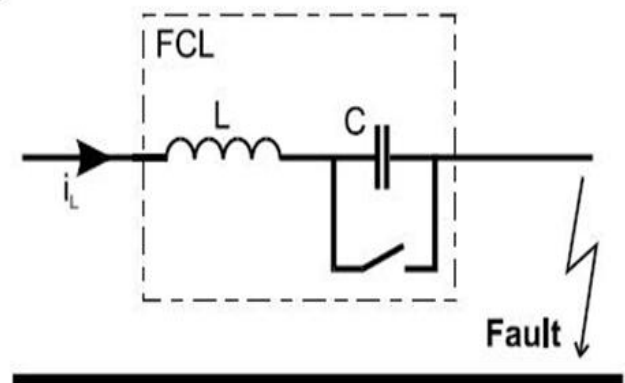

Fig.7. Resonance type solid-state FCL [19]

In December 2009, a series resonant-type FCL based on thyristor protected series capacitor (TPSC) [10],[11] is installed at the Pingyao substation of East China Power Grid, as shown in Fig. 5, which is the first 220kV and above voltage level FCL around the world. An FCL of the resonant type was designed and tested on a 23 kV/400A distribution feeder with only a limited success [22].

#### Advantages of solid state limiters

- 1) Provide significant fault current limiting impedance
- 2) Low steady state impedance as capacitors and inductors can be tuned for a particular frequency to show virtually no impedance and voltage drops.

#### Disadvantages of solid state limiters

- 1) Harmonics introduced due to switching devices
- 2) Voltage drop introduced during faults
- 3) Needs external trigger for operation
- 4) High loss also at standby

#### E. Electromagnetic Dynamic Fault Current Limiter

A DFCL is an electromagnetic FCL which automatically & instantaneously adjusts its own impedance depending upon the magnitude of the fault current. Thereby maintaining the let through current within a narrow range of values. A DFCL operates within half a cycle (8 milliseconds for 60Hz) to effectively protect downstream equipment and devices.

The DFCL operates at ambient temperature. This FCL provides variable impedance proportional to the short circuit current such that more the current tries to increase more the limiting action provided by it. It has very low power consumption and have low enough impedance up to normal currents so it does not cause poor voltage regulation at normal operating condition. These EMFCLs are self-triggered devices and automatically return back to its low impedance state after reduction of current to normal values. It is a reliable and effective current limiting solution for the smart grid. It is called "dynamic" FCL as the impedance varies with current.

The DFCL essentially works on the principle of variation of inductance and inductive reactance of a coil wound on a core which has magnetic permeability proportional to the magneto motive force (MMF) impressed upon the magnetic circuit. Such an incremental permeability leads to an increasing reactance proportional to the current passing through the coil. The permeability of the conventional magnetic materials for various flux densities is nearly constant in the operating range below magnetic saturation thus leading to nearly constant inductance and inductive reactance over a range of currents. The core material used in the DFCL has radially pre-aligned magnetic domains in the inward and outward directions as compared to conventional cores with random domain alignment [23]. DFCLs have a power rating of 9.35 MVA (12 kV, 0.45 kA) and are operating at customer plants since 2008 [24].

#### Advantages of Electromagnetic Dynamic Fault Current Limiter

- 1) DFCL limits currents for first peak and also subsequent rms value of a short circuit.
- 2) Variable impedance of DFCL ensures that even for a

high impedance fault, fault hanging is avoided.

- 3) DFCL can thermally withstand three short circuits of three seconds duration, coming in quick succession.
- 4) DFCL improve electric power quality since it responds within a quarter cycle of a fault condition and resets automatically within one cycle after fault clearance.

#### Disadvantages of Electromagnetic Dynamic Fault Current Limiter

- 1) Complicate in structure
- 2) Difficult to be applied in high power capacity system

#### F. Hybrid FCL

In 2001, Shi et al proposed a novel Triggered Vacuum Switch (TVS) based FCL. Hybrid Fault Current Limiters uses a combination of mechanical switches, solid state FCL(s), superconducting and other technologies to create current mitigation. It is a well know fact that circuit breakers and mechanical based switches suffer from delays in the few cycles range. Power electronic switches are fast in response and can open during a zero voltage crossing hence commutating the voltage across its contacts in a cycle [25].

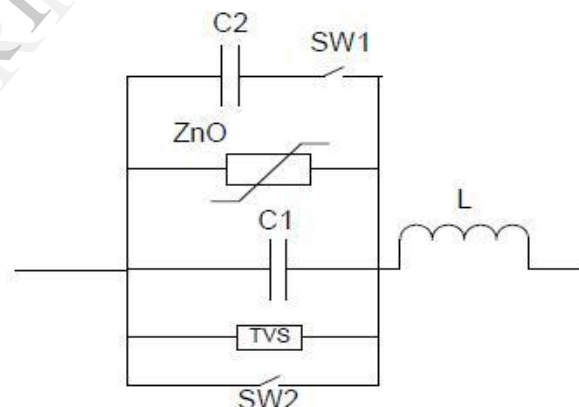

Fig. 8. Hybrid Fault Current Limiter [26]

In their work, they state that the reactance of the capacitor C1 and reactor L is about zero at nominal power frequencies. ZnO arrester is a conventional overvoltage protection device. In normal condition, the TVS and SW2 are in the off state. SW2 is a quick permanent magnetism vacuum contactor with a 3-10ms closure delay, which prevents TVS from long-time arc erosion. When a fault occurs, a trigger signal is sent to both TVS and the contactor turning on the bypass capacitor C1. This creates a situation where the reactor L will limit the fault current immediately. Capacitor C2 and switch SW1 are set-up as a conventional series compensation [26]. Fuji Electric and Kansai Electric Power Company jointly developed a hybrid 400 V with current limiting device for power distribution, which is composed of vacuum switch and GTO in parallel [27].

## Advantages of hybrid FCLs

1) High capacity,

2) Loss-free, and low price Identify the Headings

TABLE I. COMPARISON OF VARIOUS TYPES OF FAULT CURRENT LIMITERS

FCLs	Air Core Reactor	Is-Limiter	Resistive SFCL	Shielded iron-core type SFCL	Saturated Iron core Type SFCL	Solid State FCL	Electromagnetic DFCL	Hybrid FCL
Max. Rating	36 kV 2500 A	40.50 kV 2.5kA	138 kV, 0.9 kA	11kV/ 2000A	13.8 kV, 1.2 kA	69 kV, 3 kA	220 KV , 0.2 kA	12Kv, 2000 A
Triggering	Not Required	External	Internal	Internal	Internal	External	External	External
Activation Time	–	<0.5ms	<1/4 cycle	Immediately	Immediately	µs level	< 10 ms	100 ms
Reset Time	–	Non Automatic Recovery	tens of ms to 2 s	< 5ms	Immediately	Controllable	20ms	Controllable
Current Reduction	Depend on Reactor used	< 70%	< 80%	Low 20%	30% ~ 40%	Controllable	85%	controllable
Need Cooling	Yes	No	Yes	Yes	Yes	Yes (Si) No (SiC)	No	Yes
Size/Weight	Bulky	Bulky	Small	Large & Heavy	Large & Heavy	Similar to purely resistive.	compact	Small but additional components may increase size.
Status	Commercially Available	Commercially Available	Designed and tested	R&D stage	R&D Stage	development phase	Designed and tested	Research Stage

## VII.CONCLUSION

FCLs provide the opportunity to increase distribution and transmission equipment utilization and reduce reinforcement requirements. Significant research is needed into not only into how to build novel FCL devices, but also into how they operate in the system under various conditions. In recent years, FCL technology based on superconductivity and solid state has attracted greater attention. This is because with the advent of High Temperature Superconductor wires (HTS), the cooling costs have reduced significantly. In addition, with advancement in high power switching technology, solid state limiters have become viable devices. These along with superconductors are the most promising kinds of FCL(s) of the future. Significant progress in technology development resulted in the first commercially available high-temperature superconductor based resistive FCL for medium voltage levels. SFCL technologies continue to make progress toward commercialization as power utilities worldwide deal with the issue of increasing levels of fault current resulting from integration of distributed energy resources. From review of various fault current limiter (FCL) technology it is concluded that there are currently no appropriate FCL solutions commercially available to be integrated into distribution networks except for medium

voltage resistive type SFCLs. Lots of research work has already been done and lot is required to be done before these novel fault current limiter become commercially available. Effects of large penetration of FCLs in T&D networks should also be studied.

## ACKNOWLEDGMENT

The authors thank Ms. Neha Pant, Ms. Ekta Purwar and Ms. Ranjana Singh, students at National Institute of Technology, Patna for their cooperation.

## REFERENCES

- [1] K Kauhaniemi, L. K. (2004). Impact of Distributed Generation on the Protection of Distribution Networks. „University of Vaasa, Finland, VTT Technical Research Centre of Finland, Finland.
- [2] S. Sugimoto, J. Kida, H. Arita, C. Fukui, and T. Yamagiwa, "Principle and characteristics of a fault current limiter with series compensation," *IEEE Trans. Power Delivery*, vol. 11, no. 2, pp. 842–847, Apr. 1996.
- [3] Schmitt H, "Fault current limiters report on the activities of CIGRE WG A3.16," C. IEEE Power Engineering Society General Meeting, Ouebec, Canada, 2006.
- [4] G. Tang and M. R. Iravani, "Application of a Fault Current Limiter To Minimize Distributed Generation Impact on Coordinated Relay Protection," International Conference on Power Systems Transients (IPST'05) in Montreal, Canada, 2005.
- [5] Fault current limiters, Report on the CIGRE WG A3.10, by CIGRE WG



- 13.10.
- [6] Dreimann, E.; Grafe, V.; Hartung, K.H.: Schutzeinrichtungen zur Begrenzung von Kurzschlussströmen. ETZ, 115(1994)9, pp. 492-494.
- [7] E. M. Leung, "Superconducting fault current limiters," *Power Engineering Review, IEEE*, vol. 20, pp. 15-18, 30, 2000.
- [8] W. Paul and M. Chen, "Superconducting control for surge currents," *Spectrum, IEEE*, vol. 35, pp. 49-54, 1998.
- [9] M.Noë, M.Steurer, High-temperature superconductor fault current limiters: concepts, applications, and development status, *Supercond. Sci. Technol.* 20 (2007), R15-R29.
- [10] M. Chen, W. Paul, M. Lakner, L. Donzel, M. Hoidis, P. Unternaehrer, R. Weder, and M. Medik, "6.4 MVA resistive fault current limiter based on Bi-2212 superconductor," *Physica C*, vol. 372–376, pp. 1657–1663, 2002.
- [11] R. Dommerque, SKrämer, AHobl, R. Böhm, M. Bludau, J. Bock, D. Klaus, H. Piereder, A. Wilson, T. Krüger, G. Pfeiffer, K. Pfeiffer, and S. Elschner, "First commercial medium voltage superconducting fault current limiters: Production, test and installation," *Supercond. Sci. Technol.*, vol. 23, p. 034020, 2010.
- [12] H.-P. Kraemer, W. Schmidt, M. Wohlfart, H.-W. Neumueller, A. Otto, D. Verebelyi, U. Schoop, and A. P. Malozemoff, "Test of a 2 MVA medium voltage HTS fault current limiter module made of YBCO coated conductors," *Journal of Physics: Conference Series*, vol. 97, p. 012091, 2008.
- [13] Y. Y. Xie, K. Tekletsadik, D. Hazelton, and V. Selvamanickam, "Second generation high-temperature superconducting wires for fault current limiter applications," *IEEE Trans. Appl. Supercond.*, vol. 17, 2007.
- [14] AMSC, Siemens, Nexans; "Industry Leaders Successfully Demonstrate Transmission Voltage Superconductor Fault Current Limiter – American Superconductor, Nexans and Siemens Successfully Test High Voltage System", October, 2011 [Online], available: [http://www.nexans.com/Corporate/2011/Nexans\\_FCL\\_Testin\\_GB.pdf](http://www.nexans.com/Corporate/2011/Nexans_FCL_Testin_GB.pdf).
- [15] "Survey of Fault Current Limiter (FCL) Technologies", EPRI, Palo Alto, CA: 2005, 1010760
- [16] Zenergy Power Inc.; "Fault Current Limiters - Protect Today's Electrical Grid for Tomorrow's Growth", [Online], available: <http://uc-ciee.org/downloads/FCL-Overview.pdf>.
- [17] Electric Power Research Institute; "Strategic Program: Power Electronics", July 2011 [Online], available: [http://mydocs.epri.com/docs/TV/frontPage\\_pdf/1023483.PowerElectronics.pdf](http://mydocs.epri.com/docs/TV/frontPage_pdf/1023483.PowerElectronics.pdf).
- [18] K.Smedley, A.Abravomitz, Development of fault current controller technology, June, 2011.
- [19] Alexander Abramovitz and Keuye Ma Smedley "Survey of Solid-State Fault Current Limiters" IEEE transactions on power electronics, vol. 27, no. 6, june 2012
- [20] K.Smedley, A.Abravomitz, Development of fault current controller technology, June, 2011.
- [21] M.Tarafdar Hagn, MJafari, S.B.Naderi, New series resonance type fault current limiter, International Conf. on Power Systems Transients (IPST2011), june, Delft, Netherlands, 2011.
- [22] H. G. Sarmiento, "A fault current limiter based on an LC resonant circuit: Design, scale model and prototype field tests," in *Proc. iREP Symp.-Bulk Power Syst. Dyn. Control - VII, Revitalizing Oper. Rel.*, Charleston, SC, Aug. 19–24, 2007, pp. 1–5.
- [23] Prafulla Rajabhau Deo, and Tushar Pritamlal Shah; "Innovative electromagnetic dynamic fault current limiter operating at ambient temperature for smart grids", IEEE Innovative Smart Grid Technologies (ISGT), January 2010, Gaithersburg, MD.
- [24] Prafulla Rajabhau Deo, and Tushar Pritamlal Shah; "Ambient-Temperature Fault Current Limiter for Electric Ship Power Systems", IEEE Electric Ship Technologies Symposium (ESTS), April 2011, Alexandria, VA.
- [25] G. Tang and M. R. Iravani, "Application of a Fault Current Limiter To Minimize Distributed Generation Impact on Coordinated Relay Protection," *International Conference on Power Systems Transients (IPST'05) in Montreal, Canada, 2005*.
- [26] J. Shi, J. Zou, and J. He, "Triggered-vacuum switch-based fault-current limiter," *Power Engineering Review, IEEE*, vol. 20, pp. 51-53, 2000
- [27] C. W. Brice, R. A. Dougal, J. L. Hudgins, "Review of Technologies for Current-limiting Low-voltage Circuit Breakers," *IEEE Trans on Industry Applications*, No. 5, Vol. 32, pp. 41-17, 1996.