

Lawrence Berkeley National Laboratory

Recent Work

Title

RF Power Sources for Linear Colliders

Permalink

<https://escholarship.org/uc/item/6s81082j>

Author

Allen, M.A.

Publication Date

1990-06-01



Lawrence Berkeley Laboratory

UNIVERSITY OF CALIFORNIA

Accelerator & Fusion Research Division

Presented at the 2nd European Particle Accelerator Conference,
Nice, France, June 12-16, 1990,
and to be published in the Proceedings

RF Power Sources for Linear Colliders

M.A. Allen et al.

June 1990

U. C. Lawrence Berkeley Laboratory
Library, Berkeley

FOR REFERENCE

Not to be taken from this room

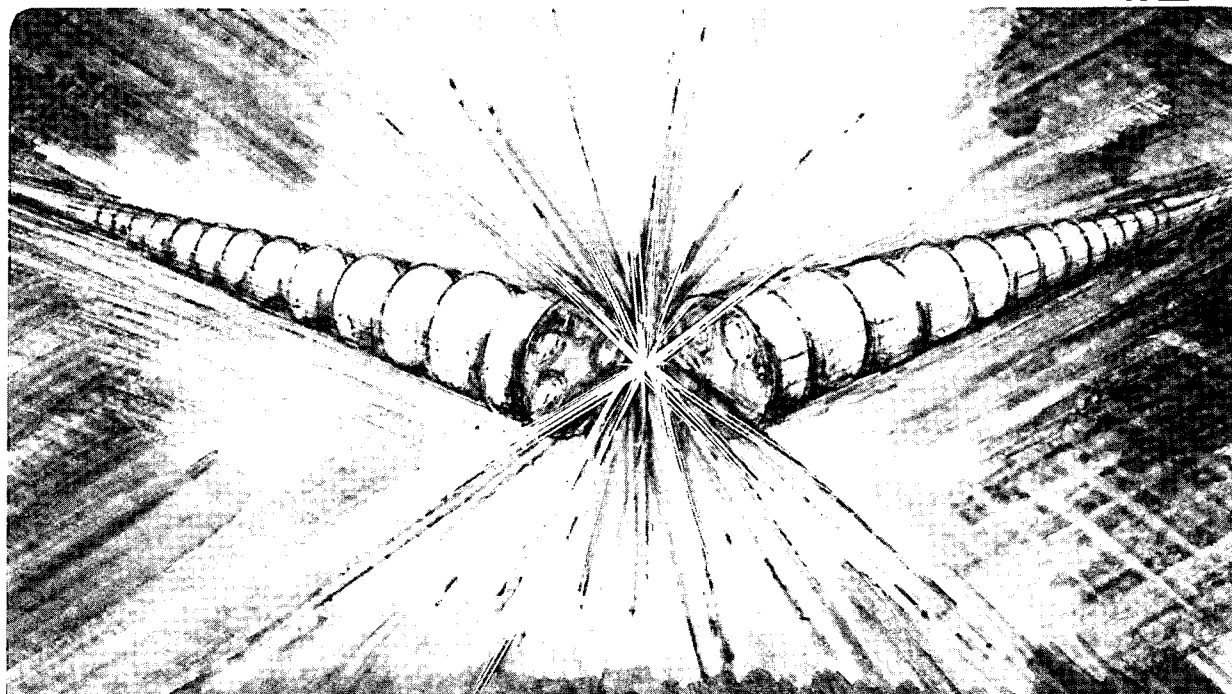

Copy 1
Ridg. 50 Library.

LBL-29458

DISCLAIMER

This document was prepared as an account of work sponsored by the United States Government. While this document is believed to contain correct information, neither the United States Government nor any agency thereof, nor the Regents of the University of California, nor any of their employees, makes any warranty, express or implied, or assumes any legal responsibility for the accuracy, completeness, or usefulness of any information, apparatus, product, or process disclosed, or represents that its use would not infringe privately owned rights. Reference herein to any specific commercial product, process, or service by its trade name, trademark, manufacturer, or otherwise, does not necessarily constitute or imply its endorsement, recommendation, or favoring by the United States Government or any agency thereof, or the Regents of the University of California. The views and opinions of authors expressed herein do not necessarily state or reflect those of the United States Government or any agency thereof or the Regents of the University of California.

RF POWER SOURCES FOR LINEAR COLLIDERS*

M. A. Allen, R. S. Callin, G. Caryotakis, H. Deruyter, K. R. Eppley, K. S. Fant, Z. D. Farkas,
 W. R. Fowkes, H. A. Hoag, J. Feinstein, K. Ko, R. F. Koontz, N. M. Kroll,† T. L. Lavine, T. G. Lee,
 G. A. Loew, R. H. Miller, E. M. Nelson, R. D. Ruth, A. E. Vlieks, J. W. Wang, and P. B. Wilson
Stanford Linear Accelerator Center, Stanford University, Stanford, CA 94309, USA

J. K. Boyd, T. Houk, R. D. Ryne, G. A. Westenskow, and S. S. Yu
University of California, Lawrence Livermore National Laboratory, Livermore, CA 94550, USA

D. B. Hopkins and A. M. Sessler
University of California, Lawrence Berkeley Laboratory, Berkeley, CA 94720, USA

J. Haimson and B. Mecklenburg
Haimson Research Corporation, Palo Alto, CA 94303, USA

Abstract: The next generation of linear colliders requires peak power sources of over 200 MW per meter at frequencies above 10 GHz at pulse widths of less than 100 nsec. Several power sources are under active development, including a conventional klystron with RF pulse compression, a relativistic klystron (RK) and a crossed-field amplifier. Power from one of these has energized a 0.5 meter two-section High Gradient Accelerator (HGA) and accelerated a beam at over 80 MeV per meter. Results of tests with these experimental devices are presented here.

1. Introduction

The RF power needed for the next generation of linear colliders in the center of mass range of 1 TeV requires the development of new sources. The parameter set presently being considered at Stanford Linear Accelerator Center (SLAC) calls for power sources every one-and-one-half meters of about 300 MW, with pulse width of 100 nsec, at 180 Hz repetition rate.¹ This provides accelerating gradient in disc-loaded waveguide of 100 MeV/m. This paper is a report on some of the work in progress on power sources at SLAC, Lawrence Berkeley Laboratory (LBL), and Lawrence Livermore National Laboratory (LLNL). The approaches covered are the relativistic klystron (RK), conventional klystron with RF pulse compression and the crossed-field amplifier (CFA). All of the experiments were conducted at 11.4 GHz, which is four times the SLAC linear accelerator frequency of 2.9 GHz. Other frequency ranges have been proposed for TeV linear colliders, from 3 GHz to 30 GHz, and while the lowest frequencies reduce the difficulties of developing power sources, they impose difficulties in other parts of the overall accelerator system. Frequencies around 10 GHz

appear to be a good compromise. This paper investigates these possibilities.

2. Relativistic Klystron

The relativistic klystron, which involves energizing a klystron with a megavolt beam produced by induction acceleration, has been developed by the SLAC/LLNL/LBL collaboration.² RK power has successfully accelerated a beam of electrons in a 25 cm length of disc-loaded waveguide.²

After this experiment, the RK was modified so that output power could be extracted from two output ports. The first output port is a standard output cavity, but is somewhat detuned from the drive frequency to permit additional bunching. The second output consists of a six cavity traveling wave section. With these modifications, a maximum total RF power of 330 MW is attained. In addition, the focussing parameters can be adjusted to permit a balanced output power of 100 MW from each port. This is suitable for testing two high gradient accelerator sections since this power level corresponds to 100 MV/m.

A two-section accelerator energized by the modified two-output RK is shown in fig. 1. Each accelerator section (HGA) is energized from a separate RK port. A beam of electrons is produced by a 50 KV electron gun. The peak electron energy is measured by bending the exiting electrons with a magnet spectrometer and capturing these electrons with a Faraday cup. Peak electron energies of 26 MeV were measured for the case where the first HGA is driven with 40 MW and the second with 80 MW. The energy spectrum at the Faraday cup is shown in fig. 2. Since the first accelerator is inefficient at capturing the electrons from the gun (the HGAs are speed-of-light

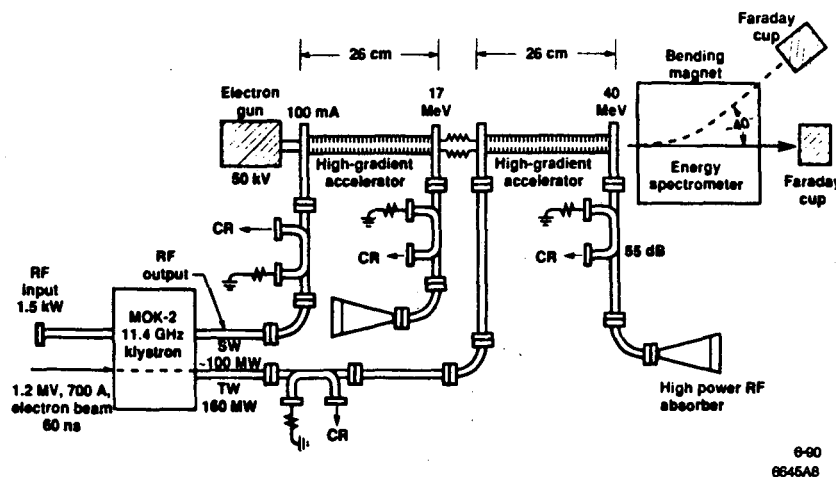

Figure 1: High gradient two-stage accelerator test.

* Work supported by Department of Energy contract DE-AC03-76SF00515 (SLAC), DE-AC03-76SF00098 (LBL), and W-7405-ENG-48 (LLNL); and by the US-Japan Collaboration on High Energy Physics.

† Permanent address: University of California, San Diego, Department of Physics, B-019, La Jolla, CA 92093, USA.

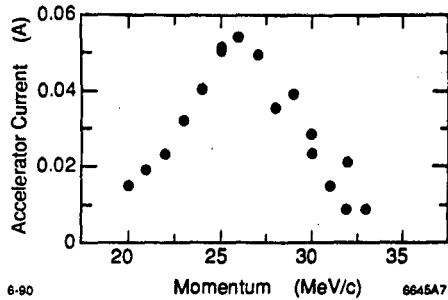

Figure 2: Energy spectrum of two-stage accelerated beam.

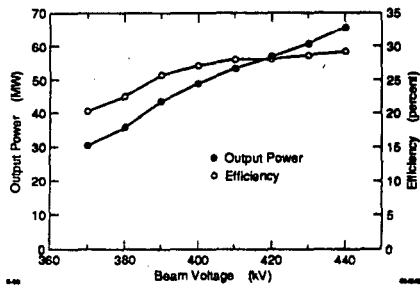

Figure 3: Measured output power vs. beam voltage for klystron.

structures), most of the acceleration takes place in the second HGA. The measured electron peak energy is therefore consistent with the expected accelerator gradient (100 MV/m at 100 MW). The maximum power we can use to accelerate electrons is currently limited by accelerator cavity breakdown. It is expected that this limitation will be somewhat ameliorated as we process the devices. Earlier, dark current was measured in both HGA sections when moderate amounts of RF power were used. For power levels of 12–14 MW in the first accelerator section and 55–60 MW in the second, 12–14 mA dark current was measured.

Peak accelerated current as a function of frequency and relative phasing between the two structures was also measured. This phasing can be varied by changing the separation of the two HGAs with a bellows arrangement in conjunction with a stepping motor. Thus, sequential acceleration at high gradient at 11.4 GHz was demonstrated.

3. Conventional Klystron

As an alternative to the RK, also under investigation at SLAC is the scheme of using a conventional klystron with an output pulse width of about 800 nsec, followed by three stages of RF pulse compression^{3,4} in order to obtain several hundred megawatts peak power of about 80 nsec duration. The first experimental klystron, designed for 100 MW output at 11.42 GHz, has been tested. Peak power output of 66 MW with 30 nsec pulse width has been attained, as shown in fig. 3. As the pulsewidth is lengthened, the achievable power output decreases as a result of beam interception and RF breakdown in the output gap. Figures 4 and 5 show the measured threshold breakdown power and the corresponding threshold breakdown gradient as a function of RF pulse width. It is seen that RF processing has a significant effect on the breakdown threshold. At 800 nsec RF pulse width, 25 MW output was available and was put to use in testing a three-stage binary pulse compressor as described below.⁴ The goal in klystron development is to produce a practical device that is a sealed-off tube capable of being repetitively pulsed at 120 pps with relatively wide pulse width, as contrasted to nanosecond sources which are essentially single-shot devices. Many of the conventional tube technologies

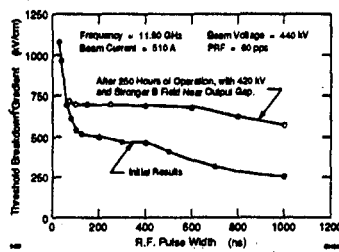

Figure 4: Measured threshold breakdown gradient vs. RF pulse width for klystron.

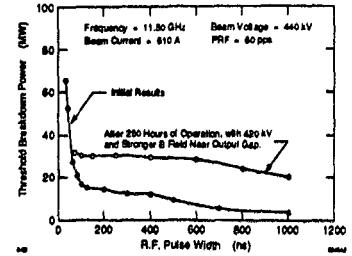

Figure 5: Measured threshold breakdown power vs. RF pulse width for klystron.

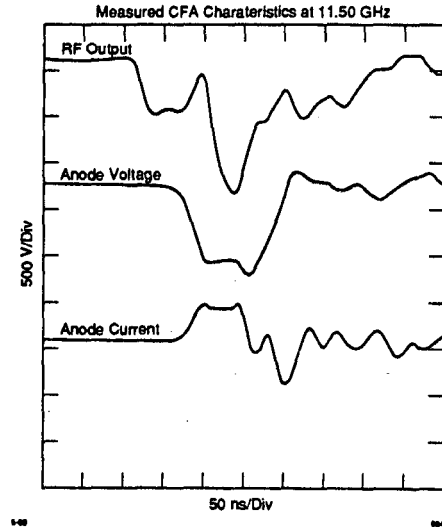

Figure 6: Measured CFA characteristics at 11.5 GHz.

are being pushed to their limits. For example, the power density in the electron beam is 316 MW/cm² at one microsecond pulse width. The focusing of a beam with these properties requires great care, or damage can easily be done to the tube. RF cavity gradients are in excess of 1 MV/cm and RF output ceramic windows are highly stressed. It is believed that the objective of 100 MW output from a conventional klystron appears to be feasible. One of the major problems is high RF gap gradients, and this can be reduced by about 40% through the use of a double-gap output cavity. Further reduction, if needed, can be obtained by use of a multicell traveling-wave output circuit, as used in the RK.

4. Crossed-Field Amplifier

While magnetron oscillators have generated single-shot powers of the order of gigawatts at nanosecond pulse widths, phase-coherent crossed-field amplifiers (CFA) with multimewatt outputs at X-Band are not common. CFAs have inherent characteristics of low impedance, compactness, high efficiency, and relatively low cost of manufacture, and as such are good potential candidates for linear collider applications where large quantities of tubes are needed. Therefore, SLAC has undertaken the development of a CFA at 11.4 GHz. The first tube was designed to operate at the backward-wave space harmonic (with a phase shift of 225°/section) and with a cold platinum cathode. Preliminary results show that a peak power of 10 MW was generated at 95 kV, 415 A, at 11.5 GHz with a pulse width of about 50 nsec. Waveforms of RF power, anode voltage and anode current are shown in fig. 6. One of the problems encountered is that the cathode current is considerably lower than expected from extrapolation of lower power CFAs. Multimode computer simulations of crossed-field interaction revealed that this may be due to interference by the underlying fast-wave forward-wave component which has a relatively strong electric

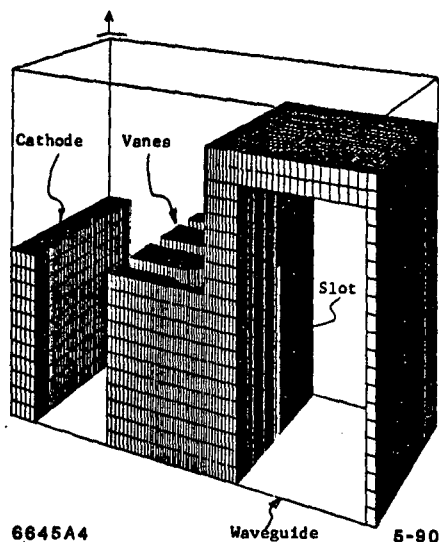

Figure 7: Simulation of waveguide-coupled anode circuit.

field at the cathode. As the RF power builds up along the circuit, this component of electric field causes the energy of the back-bombarding electrons to be so high that the secondary-emission coefficient of the platinum cathode falls below unity, thus limiting the current available. To overcome this limitation, another design is being studied which synchronizes with the forward-wave fundamental component instead of the backward-wave space harmonic. This design will have an RF circuit with a tapered impedance, resulting in constant power generated per unit length. An example of a waveguide-coupled circuit is shown in fig. 7. This circuit has the potential of producing hundreds of megawatts of peak power per tube by periodic coupling between the anode circuit and the waveguide. Because the RF voltage along the circuit is then held below a certain level, the back-bombardment energy is relatively constant. Also, multiple output ports and output windows can then be accommodated. A second tube is under design with the tapered structure and lower field at the cathode.

5. Binary RF Pulse Compression

A high-power, X-band, binary RF pulse compressor has been tested at SLAC. It is shown in schematic form in fig. 8 and is reported on in detail in these proceedings.⁴ In each of three successive stages, the RF pulse length is compressed by half, and the peak power is multiplied by 1.8. RF pulses have been compressed to 70 nsec and the peak power has been multiplied by 5.5. This technique is applicable to the requirement of high peak power and short accelerator filling times.

Low Power Tests

The peak power gain and efficiency of the binary pulse compressor have been measured using as input a 1 kW traveling wave tube (TWT). Each binary pulse compression stage has two inputs and two outputs. Power from the TWT was divided equally and fed to the two inputs of Stage 1. For each of Stages 1-3, the peak power gain is 1.8/stage; the compression efficiency is 88%/stage. (Power gain of 2/stage corresponds to efficiency of 100%.) The peak power gain and efficiency of the first three stages, taken together, are 5.5 and 68%, respectively.

Each of the two outputs of Stage 3 normally would be used to power an accelerator section. However, this binary pulse compressor has a fourth stage which permits the two Stage 3 outputs to be combined into a single output (by adjusting a high power phase-shifter). While some power is lost in the power combiner, this highest-power single output is expected to be useful for RF-breakdown studies. A single combiner output can be produced which is 1.8 times higher power than either of the Stage 3 outputs.

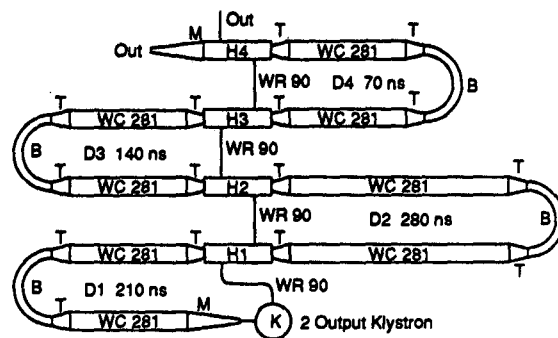

- H: 3 dB Hybrid Directional Coupler - H1 is Stage 1 etc.
- T: Taper Between Two Diameters of Circular Waveguides
- D: Delay Line Using WC281 Waveguide
- WC281: Length of 2.81 in. I.D. Circular TE⁰¹ Low-loss Circular Waveguide
- B: 180° Bend
- WR90: Short Length of Rectangular Waveguide
- M: Mode Coupler from Rectangular to Circular Waveguide

Figure 8: Schematic of three-stage one klystron RF pulse compression experiment.

High-Power Tests

High-power tests utilize as input the SLAC prototype X-Band klystron described above. The klystron output cavity feeds two waveguides with 800 nsec pulses of up to 10 MW each. (Higher power at 800 nsec is expected from the next prototype klystron.) Initial high-power tests with poorly matched input lines and incomplete signal monitoring produced 37 MW output pulses. Further high-power experiments are commencing as of this writing. For 20 MW of klystron power (split to 10 MW per input) we expect 55 MW compressed pulses at each Stage 3 output, and 98 MW compressed pulses after combining to a single output.

When two X-Band klystrons become available, the binary pulse compressor will be reconfigured to utilize both of these high-power sources. If each klystron produces 100 MW, we expect 550 MW compressed pulses at each Stage 3 output, and 980 MW compressed pulses after combining to a single output.

6. Conclusions

The RK has provided an excellent experimental source for the initial experiments with accelerator structures at very high gradients. However, the induction accelerator necessary to provide the beams for these klystrons is so costly as to probably prohibit their use in a TeV collider. Much more promising is the conventional klystron with pulse compression. However, this does require stable operation at 800 nsec with compression to 100 nsec pulses. This has yet to be demonstrated. The CFA, which is in the early stages of development, will only be of use if stable operation can be achieved above 200 MW. If one of these two approaches appears to be more feasible than the other, then the focus of further effort will be toward producing that source at low cost.

References

- [1] R. D. Ruth, "A Design for a Next Linear Collider," these proceedings.
- [2] M. A. Allen et al., "High-Gradient Electron Accelerator Powered by a Relativistic Klystron," *Phys. Rev. Lett.*, vol. 63, pp. 2472-2475, November 1989.
- [3] Z. D. Farkas, "Binary Peak Power Multiplier and its Application to Linear Accelerator Design," *IEEE TRAN. MTT-34*, 1986, p. 1036.
- [4] T. L. Lavine et al., "Binary RF Pulse Compression Experiment at SLAC," these proceedings.

LAWRENCE BERKELEY LABORATORY
UNIVERSITY OF CALIFORNIA
INFORMATION RESOURCES DEPARTMENT
BERKELEY, CALIFORNIA 94720