

RFID Coverage Extension Using Microstrip Patch Antenna Array

Mehmet Abbak, Ibrahim Tekin

*Electronics Engineering, Sabanci University
34956 Istanbul, Turkey*

Tel: ++90(216) 483 9534, Fax: ++90(216) 483 9550, e-mail: tekin@sabanciuniv.edu

Abstract— In this paper, an UHF band 2X2 microstrip phased antenna array is designed and implemented to extend the coverage of an RFID reader system. The phased antenna array has four microstrip patch antennas, three Wilkinson power dividers and a transmission line phase shifter printed on the dielectric substrate with a dielectric constant of 4.5 and on a dimensions of 34x45cm array operating at the frequency of 867 MHz, as specified in RFID Gen2 protocol European standards. The phased array antenna has a measured directivity of 12.1 dB and the main beam direction can be steered to the angles of ± 40 degrees with HPBW of 90 degrees. The phased antenna array is used as the receiving antenna in a commercial reader system; experimental results indicate that the coverage of the RFID system with the phased array antenna is superior to the with a conventional broader beamwidth microstrip patch antenna.

I. INTRODUCTION

RFID systems are now deployed in our daily lives, started to change way we live in various ways by making things easier and faster. However, due to the small size of tags and hence the antenna aperture size, for RFID systems long range operation and coverage is troublesome. In order to extend the coverage area of an RFID system, one may implement many readers and antennas with small reading ranges to cover the monitoring area or, use a high gain phased array antenna system for an extended reading range of an RFID reader for a smaller number of total reader deployments. This paper proposed a phased antenna array system for extending the coverage range of an RFID system.

For passive RFID systems in EPCglobal Class1 Gen2 RFID standard working at UHF, the working range of the RFID System is limited compared to that of active systems [1]. General purpose application RFID systems use antennas with wide beam widths and hence small gains to receive and transmit the RFID signals. Consequently, to overcome the short range limitations of RFID systems, both due to passive tags and wide beam widths; a novel phased array antenna system with higher gain can be used for beam forming for increased directivity and, hence, increased range.

The operating range of a RFID system is based on tag parameters such as, tag antenna gain and radar cross section, distances between readers, operating frequency, transmission power from reader to the tag, and gain of the reader antenna. The number of receiving and transmitting ports is another factor affecting the operation range of the system. The new approach on the RFID systems is multi-static system designs

due to its significantly better sensitivity to weak tag backscatter signals and superior RF coverage area. To demonstrate the advantage of this approach, in which two antennas can both receive and transmit, radiated power levels are plotted; for a certain signal level, bi-static approach offers larger coverage as shown in Fig. 1.

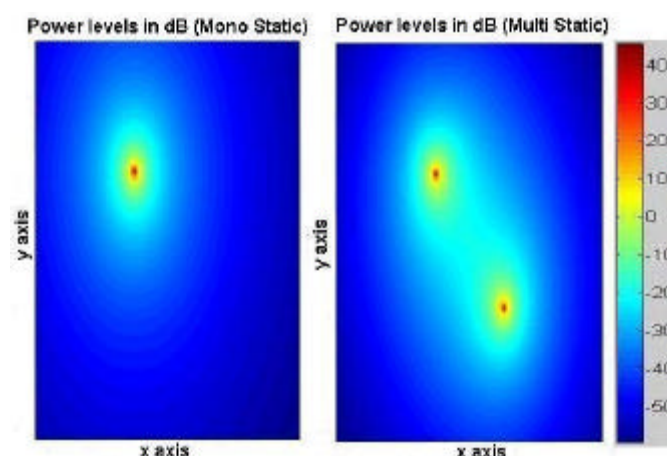

Fig. 1 Mono-Static vs. Bi-static reader coverage

Different ways of increasing range of the UHF passive RFID systems have been discussed in the literature. Increasing the sensitivity of RFID reader which can work with weaker signals received from tag, reducing power consumption, and increasing power efficiency on the tag circuit can be one way of increasing the operation range [2]. Other improvement suggestions on the design of RFID tag antenna and chip concurrently to decrease turn-on voltage of the tag chip for increased reading range operation is given in [3]. Furthermore, a theory of diversity system that could decrease the required power level for the same bit error rate, and therefore increasing operation range, is investigated in [4]. In addition, the operation range of the hand-held RFID reader for different types of patch antennas has been investigated and, shows that gain of the antenna is a fundamental factor of RFID system range in [5]. However, most applicable way of increasing the read range of UHF RFID system is increasing the gain of the reader antenna since there is a relaxed size limitation, unlike that of the RFID tag.

In this paper, the design of the microstrip patch antenna array including all the components such as Wilkinson power dividers, phase shifters, and antenna elements will be

specified. Moreover, phased array simulations and measurements will be presented. The field measurements which are taken using a commercial RFID system will be provided to show that the coverage of the RFID system is actually extended.

II. RANGE EXTENSION OF THE RFID SYSTEM USING A PHASED ARRAY ANTENNASYSTEM

The read range of a passive tag is limited by its ability to provide sufficient voltage and power at the antenna to power the tag's integrated circuit. To extend the range of an UHF passive RFID system, in a basic sense, received power should be increased. As the famous Friis transmission equation states in Eqn.1, received power is based on the transmitted power, wavelength, distance, and gains of the antennas on both TX and RX sides.

$$P_R = P_T \left(\frac{I}{4\pi R} \right)^2 G_{or} G_{or} \quad (1)$$

Where $(I/4\pi R)^2$ is called the free space loss factor, wavelength and distance are variables for this factor and, can not be changed for a certain application. Also, transmitted power P_T is also maximized to a point according to regulations on UHF RFID systems. Other remaining factors are the gains of the antennas of the reader and tag. In respect to the mono-static approach, two antennas are used on the reader side where, transmit and receive signals on separate antennas. When the reader has two antennas, receiving and transmitting purposes separately, we can conceive of as a radar system, due to transmission from tag to the reader in UHF RFID systems' is simple scattering. From this perception, received power at the receiver reader in Fig.2 can be written as Eqn.2. S is the radar cross section, a measure of an object's ability to reflect electromagnetic waves.

$$P_R = \frac{P_T * G_1 * G_2 * S}{R_1^2 * R_2^2} * \left(\frac{I}{4\pi} \right)^4 \quad (2)$$

For the maximum possible operation range, a minimum received signal level is specified. In other words, there is a minimum P_R for which the system is operable. For a fixed $P_{R,min}$, to increase the range of RFID operation,

R_1 and/or R_2 , either receiver and transmitter antenna gains G_1 or G_2 can be increased. In our approach, one of the antennas of the bi-static reader will be replaced by the phased antenna array, with a more directive beam with higher gain. Increased antenna gain will increase the radial range; however, due to the narrower beam width the angular coverage will be decreased. In our technique, the phased array can be steered to two different directions so that the angular coverage is not affected; instead, it will be extended.

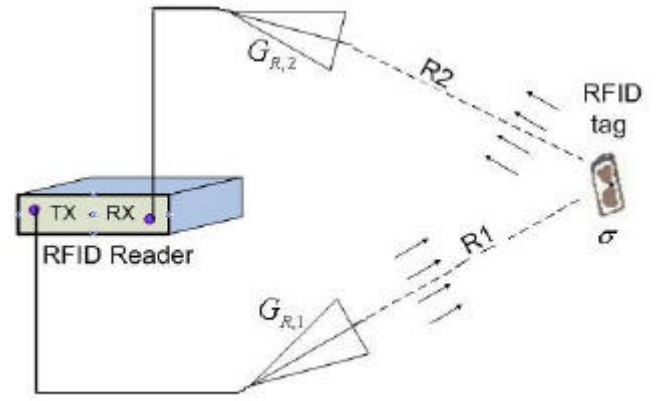

Fig. 2 Bi-static RFID System

One might argue that ERP will be increased by using high gain antenna; however, if the average power is calculated, it will be the same as fixed beam less directive antenna because the beam will be steered back and forth between these two states and, decrease the average power. In normal operation, the beam will be shifting between the two states for a predetermined amount of time.

III. IMPLEMENTATION AND RESULTS

A schematic view of the proposed antenna array is plotted in Figure 4. The phased array consists of four (2x2) patch antenna elements, Wilkinson power dividers, phase shifters enabled by SPDT switches. By using transmission line based phase shifters, the main beam of the array can be steered to two main directions, shown in Figure 3 as State1 and 2. The main purpose of steering the main beam of the array is to extend the coverage while increasing the gain of the antenna. A typical radiation pattern of a microstrip patch antenna is shown in Figure 3 as radiating into the half space, also shown in the Figure, a more directive beam of a phased antenna array with two different pointing directions.

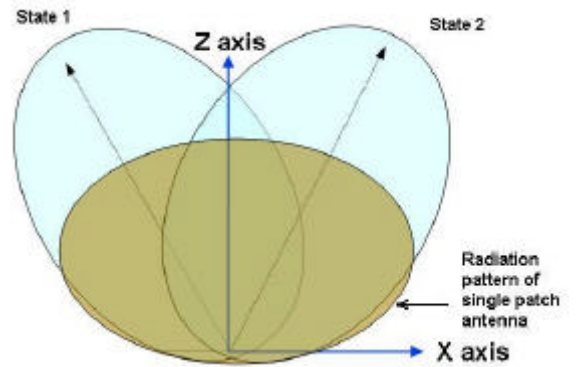

Fig. 3 Extending Coverage Area

Antenna feed network is designed to steer the beam in two directions in H-plane ($\pm 40^\circ$); this design necessitates a phase difference of 120 degree between the antenna sets (1,2) and (3,4) for 0.4 λ spacing between the antennas as shown in

Figure 4. There is no phase shift between antennas 1 and 2, 3 and 4; the spacing in x direction is set to 0.3λ and in y direction 0.4λ , to obtain the optimum gain and mutual coupling, where for extended simulations ADS Momentum 2.5D EM software is used.

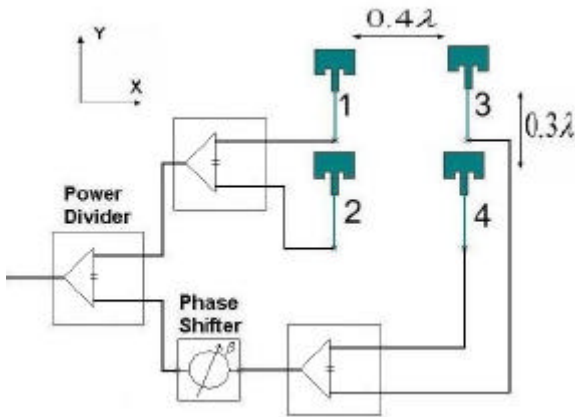

Fig. 4 Diagram of Antenna Array

Each component in the antenna array system, microstrip patch antenna, phase shifter, and Wilkinson power divider is first designed using ADS Momentum, and then, implemented, and finally measured, using Agilent 8270ES S-Parameter Network Analyzer. For the design of microstrip patch antenna, various geometry parameters and material parameters should be determined. With the use of equations for microstrip patch antenna from Balanis [6], initial values are resolved. For substrate material with a relative electric permittivity of 4.55 (ϵ_r) and thickness of 1.52mm, the PCB etching technique microstrip patch antenna is fabricated. The measured input return loss of patch antenna is given in Figure 5, where 10dB return loss bandwidth is about 15MHz, and the antenna radiates at 867MHz, with a return loss of 22dB. The radiation pattern of the patch antenna is measured in compact test range. The broadside direction pattern has better than a 15dB cross polarization at E and H planes, and 3dB bandwidth is 70° at H plane, and 80° in the E plane, with a directivity of 7.5dB as shown in Figures 6 and 7.

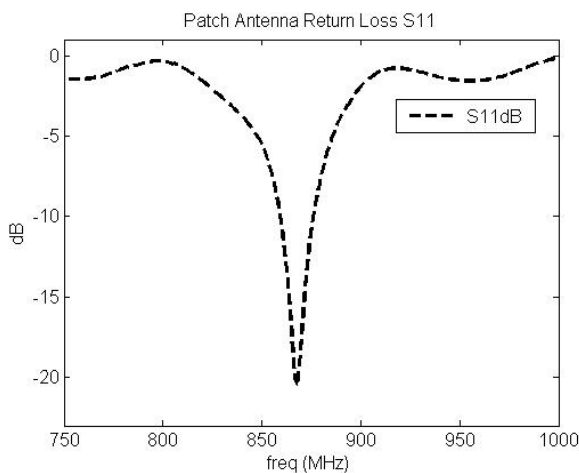

Fig. 5 Return Loss of Patch Antenna

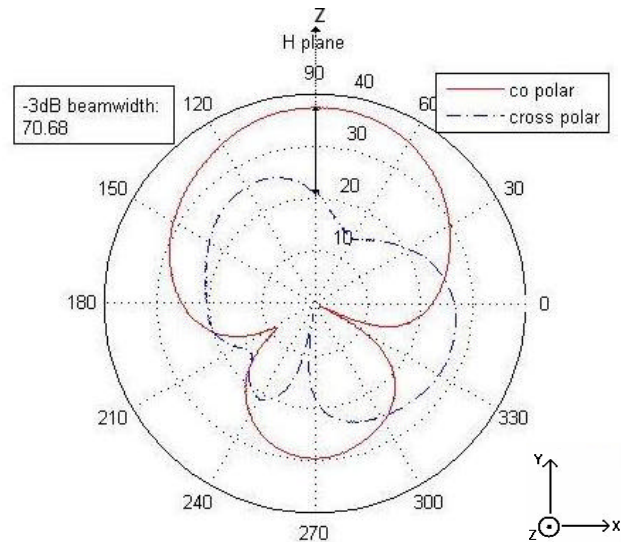

Fig. 6 Measured co- and cross-polarization (H-plane) radiation pattern

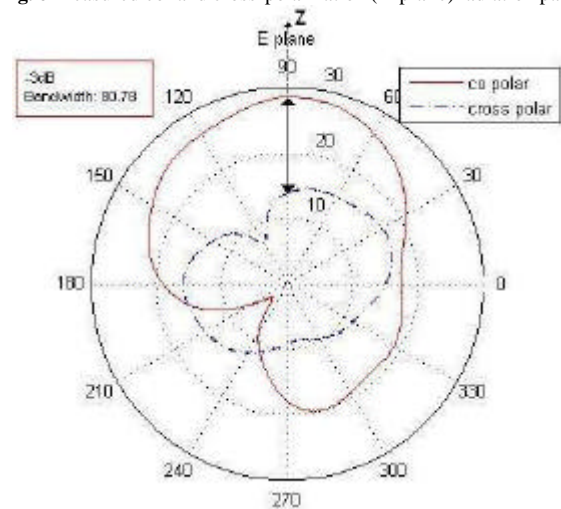

Fig. 7 Measured co- and cross-polarization (E-plane) radiation pattern

For the phase shifter implementation, a delay arm should provide additional 120° phase difference according to the reference arm because, necessary 240° phase difference between the left and right arm requires $\pm 120^\circ$ phase differences. The implemented phase shifter on FR4 substrate is shown in Figure 10. Measurement results are given in Figure 8. Insertion loss of 1.1dB and return loss of 50dB are measured for 120° phase difference (Figure 8). MA/COM High power SPDT switch chip is used to switch between the two branches of the transmission line. As a last block of the array system, the Wilkinson power divider circuit is realized and measured as shown in Figures 9 and 11. According to measurement results, power is delivered equally with an insertion loss of 0.1dB ($S_{12} \sim S_{13} \sim -3.1$ dB), alongside an isolation of 40dB at 867 MHz. (Figure 9). Finally, total array feed network composed from power dividers, phase shifter and patch antenna elements is designed appropriately, minimizing line losses and mutual coupling while maximizing array gain and efficiency [7, 9].

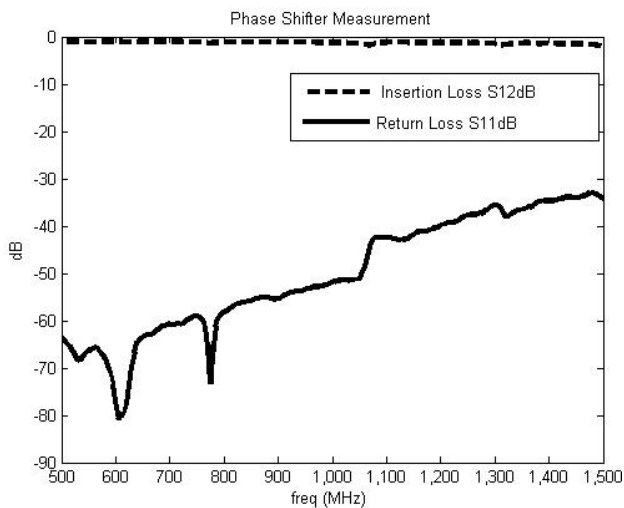

Fig. 8 Phase Shifter S-Parameters

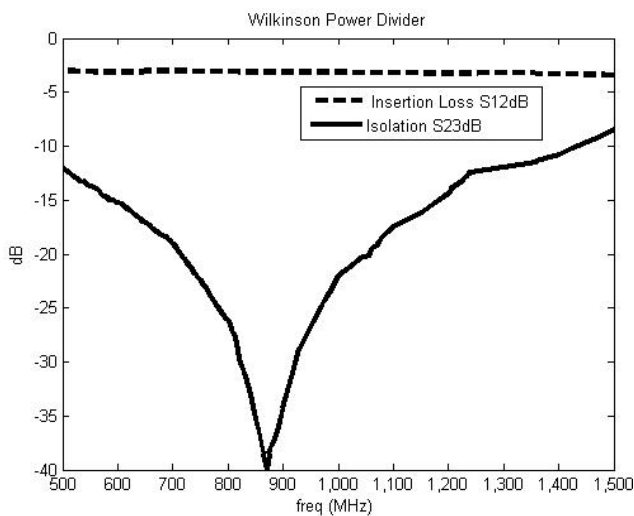

Fig. 9 Power Divider S-Parameters



Fig. 10 Phase Shifter

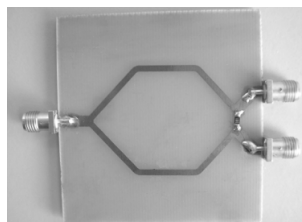

Fig. 11 Power Divider

The final layout of the RFID array antenna is shown in Figure 12 where NH9450 ($\epsilon_r = 4.5$, $\tan \delta = 0.002 @ 2\text{GHz}$ with 1.52 mm thickness) substrate is used. Figure 13 depicts the overall response of the phased array antenna for two different positions of the switches, the return loss of 30dB obtained at the resonance frequency of 867 MHz for two different main beam positions and, bandwidth covering the regulated frequencies (865.6 - 867.6) EPC Gen2 standard. The measured radiation patterns of the array for two different states of switches are shown in Figures 14 and 15. 3dB

beamwidth of H-plane for state 1 is 46° , and for state 2, beamwidth is 48° . For E-plane, when upper switches of phase shifter are open, half power beamwidth is 69.3° (State 2), and otherwise, beamwidth is 73.6° (State 1). In accordance with simulation results, directivity of 12.1 dB and 20dB difference of co and cross polar level at boresight is obtained at 867 MHz from the measurements. The measured results show that antenna can be steered ± 40 degrees.

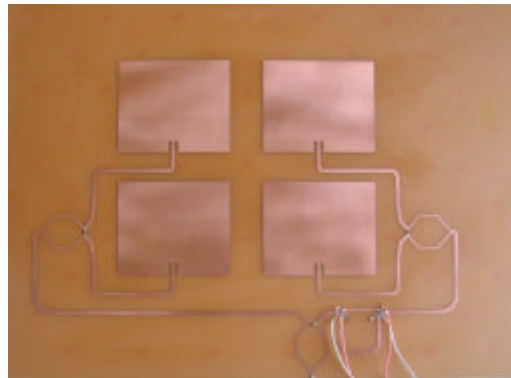

Fig. 12 Array Antenna

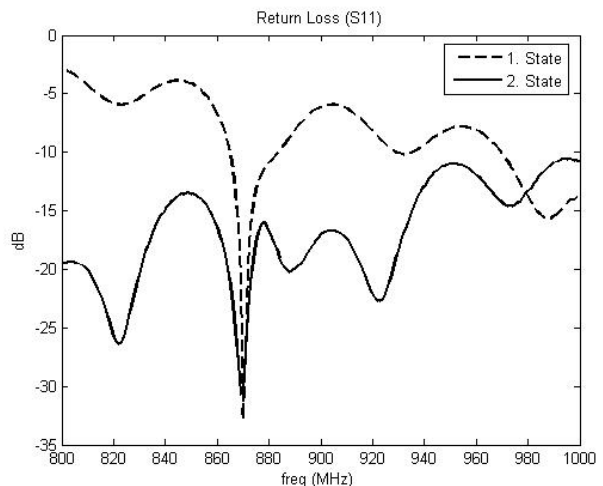

Fig. 13 S11 of the array antenna

IV. EXPERIMENTAL RESULTS

A test bench to assess the performance of a phased array antenna in an actual RFID system to confirm the radiation pattern measurements completed in the compact range has been established. For testing purposes, Alien bi-static ALR-8800 model reader and passive UHF ALN-9554 tags have been used [10]. The array antenna was employed in the receiver port and standard patch for transmission. For different positions of receiver antennas, the standard patch antenna and antenna array in two different states, measurement results affirm the extended coverage and gain of antenna array as compared to those of the patch antenna (Figure 16). Due to the limited area for measurements transmitted power level decreased by 6dB from the max

power level obtainable (2watts), in order to minimize the coverage.

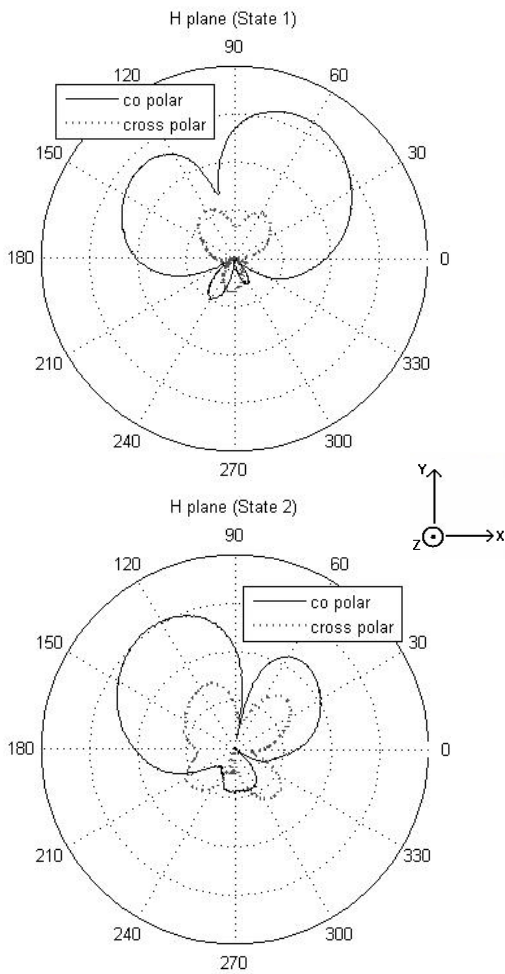

Fig. 14 Measured co- and cross-polarization (H-plane) for two states of phased array antenna

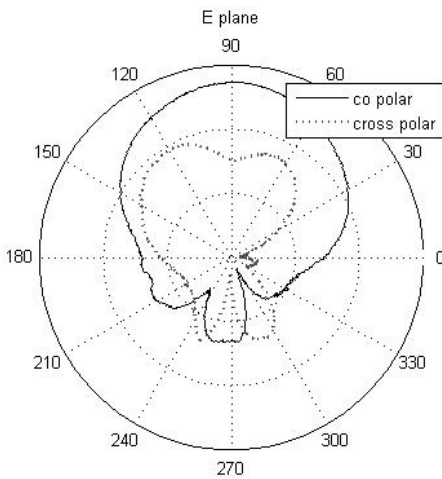

Fig. 15 Measured co- and cross-polarization (E-plane) phased array antenna

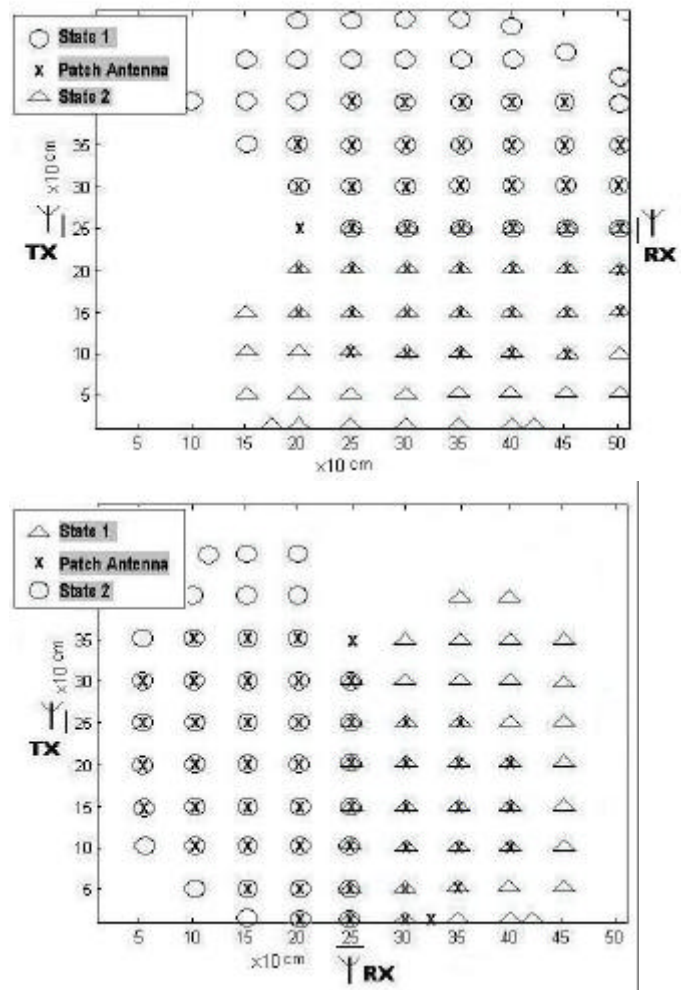

Fig. 16 Readable location information of UHF passive tags

V. CONCLUSION

The 2x2 UHF RFID antenna array system, which consists of phase shifter, power dividers and microstrip patch antenna element, at operation frequency of 867 MHz, is designed, implemented, and measured. The main beam of the antenna array can be switched between two directions designed at 80° degrees apart. The measured input impedance is well matched with two different beam pointing directions with return losses of 30dB. The radiation pattern of antenna is measured and plotted in compact range, and also to corroborate the results, the performance of antenna array has been tested in an actual UHF RFID system.

VI. REFERENCES

- [1] K. Finkenzeller, *RFID Handbook*, 2nd edition, John Wiley & Sons, England, 2003.
- [2] G. De Vita , G. Iannaccone, "Design Criteria for the RF Section of Long Range Passive WID Systems"
- [3] Jong-Wook Lee, Hongil Kwon, and Bomson Lee, "Design Consideration of UHF RFID Tag for Increased Reading Range"
- [4] Joshua D. Griffin, Gregory D. Durgin, "Gains For RF Tags Using Multiple Antennas". *IEEE TRANSACTIONS ON ANTENNAS AND PROPAGATION*, VOL. 56, NO. 2, FEBRUARY 2008
- [5] Leena Ukkonen, Lauri Sydänheimo, Markku Kivikoski, "Read Range Performance Comparison of Compact Reader Antennas for a Handheld UHF RFID Reader" *IEEE International Conference on RFID 2007*
- [6] Balanis, Constantine A. *Antenna Theory*, John Wiley & Sons, Inc.
- [7] E. Levine, G. Malamud, S. Shtrikman, and D. Treves, "A study of microstrip array antennas with the feed network," *IEEE Trans. Antennas Propagation*. vol. 37, pp. 426-434, Apr. 1989.
- [8] P. S. Hall and C. M. Hall, "Co-planar corporate feed effects in microstrip patch array design," *Inst. Elect. Eng. Proc.*, vol. 135, pt. H, pp. 180-186, June 1988.
- [9] Daniel, P., Dubost, G., Tenet, C., Citeme, J. and Drissi, M. "Research on planar antennas and arrays: Structure Rayonnantes"
- [10] RFID system. Available at <http://www.alientechnology.com>