

Robust H^∞ Stabilization of a Nonlinear Uncertain System via a Stable Nonlinear Output Feedback Controller

Hendra G. Harno

Ian R. Petersen

Abstract—A new approach to solving a nonlinear robust H^∞ control problem using a stable nonlinear output feedback controller is presented in this paper. The particular class of nonlinear uncertain systems being considered is characterized in terms of Integral Quadratic Constraints and Global Lipschitz Conditions describing the admissible uncertainty and nonlinearity, respectively. The nonlinear controller is then constructed by including a copy of the system nonlinearity in the structure of the linear controller. The aim is to enable the controller to exploit the nonlinearity of the system such that it will absolutely stabilize the closed loop nonlinear system and achieve a specified disturbance attenuation level. This method involves the stabilizing solutions of a pair of algebraic Riccati equations.

I. INTRODUCTION

In many applications, a stable controller is preferable to an unstable controller because the latter is sensitive to actuator and sensor failures and also to plant uncertainties and nonlinearities (e.g., see [1], [2]). It can also reduce the performance of the closed loop system in tracking a reference signal and rejecting disturbances (e.g., see [3]). Thus, many approaches have been proposed to construct a stable controller. They have used various properties and parameterization techniques such as the parity interlacing property (see [4]), an interpolation condition (see [5]), a unimodular transfer function matrix (see [3]), inner-outer factorization (see [2]) and parameterized H^∞ optimization (see [1], [6], [7]). However, those methods dealt only with linear controller design problems.

In this paper, we are interested in obtaining a nonlinear controller that will both stabilize the closed loop system and yield robustness against uncertainty, nonlinearity and perturbations. In fact, there have been several nonlinear controller synthesis methods such as optimal nonlinear H^∞ control theory (see [8]), constructive nonlinear control theory (e.g., see [9], [10]) and the circle and Popov criteria (see [11]). However, these methods do not necessarily lead to a stable nonlinear controller in the output feedback case.

These facts have motivated us to propose a new approach to solve the nonlinear robust H^∞ control problem via a stable nonlinear output feedback controller. A related discrete-time approach can be found in [12] for the finite time horizon case without the requirement for a stable controller. Indeed, a method to construct a stable robust H^∞ output feedback

controller has been presented in [13]. However, the approach of [13] yields a linear controller and it would require the known nonlinearity to be treated as an uncertainty. Whereas, in our method, we do not consider the known nonlinearity as an uncertainty so as to have a less conservative stable nonlinear controller.

The particular class of nonlinear uncertain systems under consideration is described in terms of Integral Quadratic Constraints (IQCs) and Global Lipschitz Conditions (GLCs) corresponding to the admissible uncertainty and nonlinearity, respectively (e.g., see [14]). Such nonlinear uncertain systems have also been considered in [15] in a guaranteed cost control problem and without a requirement for controller stability.

There are two main ideas underlying our approach. Firstly, we adjust the standard IQC approach to robust H^∞ control by adding a copy of the known part of the plant nonlinearity to the linear controller (see Fig. 1). This technique resembles the one used in [16] for observer-based control systems and in [17] for Linear Parameter Varying (LPV) controller design. The aim is to enable the linear controller to exploit the plant nonlinearity when we establish the absolute stability of the whole system. Secondly, the linear part of this nonlinear controller is synthesized using the method in [18]. Thus, both nonlinearities are first combined into the plant (see Fig. 2) and then characterized by extra IQCs derived from the GLCs.

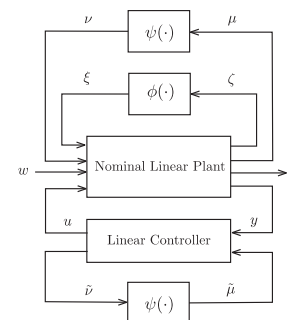

Fig. 1. Nonlinear uncertain system with nonlinear controller. Here $\psi(\cdot)$ is a known nonlinearity and $\phi(\cdot)$ is an uncertainty.

Moreover, in order to guarantee controller stability, we introduce an additional uncertainty to form a new uncertain system. For a certain value of the additional uncertainty, the new uncertain system reduces to the original uncertain system. Thus, if a suitable controller for the new uncertain system exists, then it also solves the absolute stabilization problem with a specified disturbance attenuation level for

This work was supported by the Australian Research Council.
 Hendra G. Harno and Ian R. Petersen are with the School of Information Technology and Electrical Engineering, University of New South Wales at the Australian Defence Force Academy, Canberra ACT 2600, Australia.
 h.harno@adfa.edu.au; i.r.petersen@gmail.com

(6), (7) for the nonlinear uncertain system (1), (2), (5). To achieve this, the nonlinearities (7) are incorporated into the plant description as shown in Fig. 2. Then, the inputs and outputs of (6) are respectively combined such that

$$\begin{aligned} \tilde{B}_c &= [B_c \ B_c^{\tilde{\mu}}] = [B_c \ L_1 \ \cdots \ L_g]; \\ \tilde{C}_c &= \begin{bmatrix} C_{c1} \\ C_c^{\tilde{\nu}} \end{bmatrix}; \tilde{y}(t) = \begin{bmatrix} y(t) \\ \tilde{\mu}(t) \end{bmatrix}; \tilde{u}(t) = \begin{bmatrix} u(t) \\ \tilde{\nu}(t) \end{bmatrix}; \\ C_c^{\tilde{\nu}} &= \begin{bmatrix} C_{c2,1} \\ \vdots \\ C_{c2,g} \end{bmatrix}; \tilde{\mu}(t) = \begin{bmatrix} \tilde{\mu}_1(t) \\ \vdots \\ \tilde{\mu}_g(t) \end{bmatrix}; \tilde{\nu}(t) = \begin{bmatrix} \tilde{\nu}_1(t) \\ \vdots \\ \tilde{\nu}_g(t) \end{bmatrix}. \end{aligned} \quad (8)$$

The controller state equations (6) can then be rewritten as

$$\begin{aligned} \dot{x}_c(t) &= A_c x_c(t) + \tilde{B}_c \tilde{y}(t); \\ \tilde{u}(t) &= \tilde{C}_c x_c(t). \end{aligned} \quad (9)$$

Thus, the problem of controlling the nonlinear uncertain system (1), (2), (5) using the nonlinear controller (6), (7) is equivalent to that of controlling the nonlinear uncertain system (1), (2), (5), (7) using the linear controller (9).

The notion of absolute stabilizability for the nonlinear uncertain system (1), (2), (5) is defined as follows:

Definition 2: (e.g., see [14].) The uncertain system (1), (2), (5) is said to be *absolutely stabilizable with disturbance attenuation level* γ via a stable output feedback controller (7), (9) if there exists constants $c_1 > 0$ and $c_2 > 0$ such that the following conditions hold:

- 1) For any initial condition $[x(0), x_c(0)]$, any admissible uncertainty inputs $\xi(\cdot)$ and any disturbance input $w(\cdot) \in \mathbf{L}_2[0, \infty)$, then $[x(\cdot), x_c(\cdot), u(\cdot), \xi_1(\cdot), \dots, \xi_f(\cdot)] \in \mathbf{L}_2[0, \infty)$ (hence, $t_* = \infty$) and

$$\begin{aligned} &\|x(\cdot)\|_2^2 + \|x_c(\cdot)\|_2^2 + \|u(\cdot)\|_2^2 + \sum_{s=1}^f \|\xi_s(\cdot)\|_2^2 \\ &\leq c_1 \left[\|x(0)\|^2 + \|x_c(0)\|^2 + \|w(\cdot)\|_2^2 + \sum_{s=1}^f d_{1,s} \right]. \end{aligned} \quad (10)$$

- 2) The following H^∞ norm bound condition is satisfied: If $x(0) = 0$ and $x_c(0) = 0$, then for $w(\cdot) \in \mathbf{L}_2[0, \infty)$ and $\xi(\cdot) \in \Xi$

$$\mathcal{J} := \sup_{w(\cdot)} \sup_{\xi(\cdot)} \frac{\|z(\cdot)\|_2^2 - c_2 \sum_{s=1}^f d_{1,s}}{\|w(\cdot)\|_2^2} < \gamma^2. \quad (11)$$

Here, $\|q(\cdot)\|_2$ denotes the $\mathbf{L}_2[0, \infty)$ norm of a function $q(\cdot)$. That is, $\|q(\cdot)\|_2^2 := \int_0^\infty \|q(t)\|^2 dt$. \triangle

In order to apply the result of [18], the nonlinearities (2) and its copies (7) need to be characterized using IQCs. This will be done by referring to conditions (3) which imply

$$\begin{aligned} |\mu_i(t) - \tilde{\mu}_i(t)|^2 &\leq \beta_i^2 [\nu_i(t) - \tilde{\nu}_i(t)]^2; \\ |\mu_i(t)|^2 &\leq \beta_i^2 \nu_i(t)^2; \\ |\tilde{\mu}_i(t)|^2 &\leq \beta_i^2 \tilde{\nu}_i(t)^2 \end{aligned} \quad (12)$$

for all $i = 1, 2, \dots, g$. Thus, the following IQCs corresponding to (12) will be satisfied

$$\begin{aligned} \int_0^{t_k} (\mu_i(t) - \tilde{\mu}_i(t))^2 dt &\leq \int_0^{t_k} \beta_i^2 (\nu_i(t) - \tilde{\nu}_i(t))^2 dt + d_{2,i}; \\ \int_0^{t_k} (\mu_i(t))^2 dt &\leq \int_0^{t_k} \beta_i^2 (\nu_i(t))^2 dt + d_{3,i}; \\ \int_0^{t_k} (\tilde{\mu}_i(t))^2 dt &\leq \int_0^{t_k} \beta_i^2 (\tilde{\nu}_i(t))^2 dt + d_{4,i} \end{aligned} \quad (13)$$

for all $i = 1, 2, \dots, g$; and for all $\{t_k \geq 0\}_{k=1}^\infty$. Note that $d_{2,i} \geq 0$, $d_{3,i} \geq 0$ and $d_{4,i} \geq 0$.

Although the extra IQCs (13) provide more constraints, in addition to (5), they indeed allow the description of the uncertain system (1) to be simplified as follows:

$$\begin{aligned} \dot{x}(t) &= Ax(t) + B_1 w(t) + \tilde{B}_2 \tilde{u}(t) + \sum_{s=1}^{\tilde{f}} \tilde{E}_s \tilde{\xi}_s(t); \\ z(t) &= C_1 x(t) + \tilde{D}_{12} \tilde{u}(t); \\ \tilde{\zeta}_1(t) &= \tilde{H}_1 x(t) + \tilde{G}_1 \tilde{u}(t); \\ &\vdots \\ \tilde{\zeta}_{\tilde{f}}(t) &= \tilde{H}_{\tilde{f}} x(t) + \tilde{G}_{\tilde{f}} \tilde{u}(t); \\ \tilde{y}(t) &= \tilde{C}_2 x(t) + \tilde{D}_{21} w(t) + \sum_{s=1}^{\tilde{f}} \tilde{F}_s \tilde{\xi}_s(t) \end{aligned} \quad (14)$$

where

$$\begin{aligned} \tilde{\xi}(t) &= \begin{bmatrix} \xi(t) \\ \mu(t) \\ \tilde{\mu}(t) \end{bmatrix}; \tilde{\zeta}(t) = \begin{bmatrix} \zeta(t) \\ \nu(t) \\ \tilde{\nu}(t) \end{bmatrix}; \xi(t) = \begin{bmatrix} \xi_1(t) \\ \vdots \\ \xi_f(t) \end{bmatrix}; \\ \zeta(t) &= \begin{bmatrix} \zeta_1(t) \\ \vdots \\ \zeta_f(t) \end{bmatrix}; \mu(t) = \begin{bmatrix} \mu_1(t) \\ \vdots \\ \mu_g(t) \end{bmatrix}; \nu(t) = \begin{bmatrix} \nu_1(t) \\ \vdots \\ \nu_g(t) \end{bmatrix}; \\ \tilde{B}_2 &= [B_2 \ 0_{n \times g}]; \tilde{C}_2 = \begin{bmatrix} C_2 \\ 0_{g \times n} \end{bmatrix}; \\ \tilde{D}_{12} &= [D_{12} \ 0_{q \times g}]; \tilde{D}_{21} = \begin{bmatrix} D_{21} \\ 0_{g \times p} \end{bmatrix}; \\ \tilde{E} &= [E_1 \ E_2 \ 0_{n \times g}]; \tilde{F} = \begin{bmatrix} F_1 & F_2 & 0_{l \times g} \\ 0_{g \times r} & 0_{g \times g} & I_{g \times g} \end{bmatrix}; \\ E_1 &= [E_{1,1} \ \cdots \ E_{1,f}]; E_2 = [E_{2,1} \ \cdots \ E_{2,g}]; \\ F_1 &= [F_{1,1} \ \cdots \ F_{1,f}]; F_2 = [F_{2,1} \ \cdots \ F_{2,g}]; \\ \tilde{H} &= \begin{bmatrix} H_1 \\ H_2 \\ 0_{g \times n} \end{bmatrix}; H_1 = \begin{bmatrix} H_{1,1} \\ \vdots \\ H_{1,f} \end{bmatrix}; H_2 = \begin{bmatrix} H_{2,1} \\ \vdots \\ H_{2,g} \end{bmatrix}; \\ \tilde{G} &= \begin{bmatrix} G_1 & 0_{h \times g} \\ G_2 & 0_{g \times g} \\ 0_{g \times m} & I_{g \times g} \end{bmatrix}; G_1 = \begin{bmatrix} G_{1,1} \\ \vdots \\ G_{1,f} \end{bmatrix}; G_2 = \begin{bmatrix} G_{2,1} \\ \vdots \\ G_{2,g} \end{bmatrix}. \end{aligned} \quad (15)$$

Note that $\tilde{f} = f + 2g$; $r = \sum_{s=1}^f r_s$; $\tilde{r} = r + 2g$; $h = \sum_{s=1}^f h_s$; and $\tilde{h} = h + 2g$.

It is also straightforward to combine all IQCs (5), (13) into the form

$$\int_0^{t_k} \tilde{\xi}(t)' Q_j \tilde{\xi}(t) dt \leq \int_0^{t_k} \tilde{\zeta}(t)' R_j \tilde{\zeta}(t) dt + d_j \quad (16)$$

for all $j = 1, 2, \dots, \hat{f}$. Here, $\hat{f} = f + 3g$ and $d_j \geq 0$. The set of all admissible uncertainty inputs $\tilde{\xi}(\cdot)$ for the uncertain system (14), (16) is defined in the same way as in Definition 1 and is denoted by $\tilde{\Xi}$.

In order to apply the results of [18] and [13], it is necessary to define the Lagrange multipliers λ_j , weighting matrices $\tilde{Q}(\lambda)$ and $\tilde{R}(\lambda)$, and a constant $\tilde{d}(\lambda)$ as follows

$$\begin{aligned} \lambda &:= [\lambda_1 \quad \dots \quad \lambda_{\hat{f}}]' \in \mathbf{R}^{\hat{f}}; \quad \tilde{Q}(\lambda) := \sum_{j=1}^{\hat{f}} \lambda_j Q_j \geq 0; \\ \tilde{R}(\lambda) &:= \sum_{j=1}^{\hat{f}} \lambda_j R_j \geq 0; \quad \tilde{d}(\lambda) := \sum_{j=1}^{\hat{f}} \lambda_j d_j \geq 0; \end{aligned} \quad (17)$$

and also a subset

$$\tilde{\Lambda} := \left\{ \lambda \in \mathbf{R}^{\hat{f}} : \lambda_j \geq 0 \forall j, \tilde{Q}(\lambda) > 0 \right\} \quad (18)$$

such that the IQCs (16) leads to the satisfaction of an IQC parameterized by Lagrange multipliers as in (17). Then, for each $\lambda \in \tilde{\Lambda}$, the quantities defined in (17) can be written as

$$\begin{aligned} \tilde{Q}(\lambda) &= \bar{Q}(\lambda) \bar{Q}(\lambda); \quad \tilde{R}(\lambda) = \bar{R}(\lambda)' \bar{R}(\lambda); \\ \tilde{d}(\lambda) &= \bar{d}(\lambda) = \sum_{j=1}^{\hat{f}} \lambda_j d_j \geq 0. \end{aligned} \quad (19)$$

where $\bar{Q}(\lambda) = \tilde{Q}(\lambda)^{\frac{1}{2}} > 0$ and $\bar{R}(\lambda)$ is a rectangular matrix. However, in particular, $\bar{R}(\lambda)$ can be chosen to be a square matrix such that $\bar{R}(\lambda) = \bar{R}(\lambda)^{\frac{1}{2}} > 0$. Then, the IQC (16) can be written as

$$\int_0^{t_k} \tilde{\xi}(t)' \bar{Q}(\lambda) \tilde{\xi}(t) dt \leq \int_0^{t_k} \tilde{\zeta}(t)' \bar{R}(\lambda) \tilde{\zeta}(t) dt + \bar{d}(\lambda) \quad (20)$$

or more compactly

$$\int_0^{t_k} \|\tilde{\xi}(t)\|^2 dt \leq \int_0^{t_k} \|\tilde{\zeta}(t)\|^2 dt + \bar{d}(\lambda) \quad \forall k \quad (21)$$

where

$$\bar{\xi}(t) := \bar{Q}(\lambda) \tilde{\xi}(t); \quad \bar{\zeta}(t) := \bar{R}(\lambda) \tilde{\zeta}(t). \quad (22)$$

Accordingly, the system (14) can be described as

$$\begin{aligned} \dot{x}(t) &= Ax(t) + B_1 w(t) + \tilde{B}_2 \tilde{u}(t) + \tilde{E} \bar{Q}(\lambda)^{-1} \bar{\xi}(t); \\ z(t) &= C_1 x(t) + \tilde{D}_{12} \tilde{u}(t); \\ \bar{\zeta}(t) &= \bar{R}(\lambda) \tilde{H} x(t) + \bar{R}(\lambda) \tilde{G} \tilde{u}(t); \\ \tilde{y}(t) &= \tilde{C}_2 x(t) + \tilde{D}_{21} w(t) + \tilde{F} \bar{Q}(\lambda)^{-1} \bar{\xi}(t). \end{aligned} \quad (23)$$

Thus, the desired controller will be constructed based on the uncertain system (23), (21).

III. THE MAIN RESULTS

In this section, a method to construct a stable nonlinear output feedback controller is presented. The resulting controller not only achieves absolute stabilization with disturbance attenuation γ when applied to the uncertain system (23), (21), but also the controller itself must be stable. The main idea used to solve this problem involves introducing an additional uncertainty into the uncertain system (23), (21).

This approach will lead to a new artificial uncertain system that is obtained by first solving a state feedback problem for the uncertain system (23), (21). To obtain a state feedback controller using the result of [18], the uncertain system (23), (21) needs to be converted into the following form

$$\begin{aligned} \dot{x}(t) &= Ax(t) + \tilde{B}_1 \tilde{w}(t) + \tilde{B}_2 \tilde{u}(t); \\ \tilde{z}(t) &= \tilde{C}_1 x(t) + \tilde{D}_{12} \tilde{u}(t); \\ \tilde{y}(t) &= \tilde{C}_2 x(t) + \tilde{D}_{21} \tilde{w}(t) \end{aligned} \quad (24)$$

where

$$\begin{aligned} \tilde{w}(t) &= \begin{bmatrix} \gamma w(t) \\ \sqrt{\kappa} \tilde{\xi}(t) \end{bmatrix}; \quad \tilde{z}(t) = \begin{bmatrix} z(t) \\ \sqrt{\kappa} \tilde{\zeta}(t) \end{bmatrix}; \\ \tilde{B}_1(t) &= \begin{bmatrix} \gamma^{-1} B_1 & \sqrt{\kappa}^{-1} \tilde{E} \bar{Q}(\lambda)^{-1} \end{bmatrix}; \\ \tilde{C}_1 &= \begin{bmatrix} C_1 \\ \sqrt{\kappa} \bar{R}(\lambda) \tilde{H} \end{bmatrix}; \quad \tilde{D}_{12} = \begin{bmatrix} \tilde{D}_{12} \\ \sqrt{\kappa} \bar{R}(\lambda) \tilde{G} \end{bmatrix}; \\ \tilde{D}_{21} &= \begin{bmatrix} \gamma^{-1} \tilde{D}_{21} & \sqrt{\kappa}^{-1} \tilde{F} \bar{Q}(\lambda)^{-1} \end{bmatrix}. \end{aligned} \quad (25)$$

Note that $\gamma > 0$ is the desired disturbance attenuation level and $\kappa > 0$ is a Lagrange multiplier parameter. The latter is introduced to convert the constrained control problem into an unconstrained one. We then construct a state feedback controller for (24) to obtain an absolutely stable closed loop system. Thus, the control input will be of the form

$$\tilde{u}(t) = Kx(t) \quad (26)$$

where

$$K = \begin{bmatrix} K_u \\ K_v \end{bmatrix} = -J^{-1} \left(\tilde{B}'_2 X + \tilde{D}'_{12} \tilde{C}_1 \right) \quad (27)$$

with $J = \tilde{D}'_{12} \tilde{D}_{12} > 0$ and $X > 0$ is the stabilizing solution of the following Riccati equation (see [19])

$$\begin{aligned} \left(A - \tilde{B}_2 J^{-1} \tilde{D}'_{12} \tilde{C}_1 \right)' X + X \left(A - \tilde{B}_2 J^{-1} \tilde{D}'_{12} \tilde{C}_1 \right) \\ + X \left(\tilde{B}_1 \tilde{B}'_1 - \tilde{B}_2 J^{-1} \tilde{B}'_2 \right) X \\ + \tilde{C}'_1 \left(I - \tilde{D}_{12} J^{-1} \tilde{D}'_{12} \right) \tilde{C}_1 = 0. \end{aligned} \quad (28)$$

Suppose that the state feedback gain matrix K in (27) has been found. Then it can be used to define a new artificial uncertain system as follows

$$\begin{aligned} \dot{x}(t) &= \bar{A}x(t) + B_1 w(t) + \bar{B}_2 \tilde{u}(t) + \bar{E}_1 \bar{\xi}_1(t) + \bar{E}_2 \bar{\xi}_2(t); \\ z(t) &= \bar{C}_1 x(t) + M_1 \bar{\xi}_2(t) + \bar{D}_{12} \tilde{u}(t); \\ \bar{\xi}_1(t) &= \bar{H}_1 x(t) + M_2 \bar{\xi}_2(t) + \bar{G}_1 \tilde{u}(t); \\ \bar{\xi}_2(t) &= \bar{H}_2 x(t) + \bar{G}_2 \tilde{u}(t); \\ \tilde{y}(t) &= \tilde{C}_2 x(t) + \tilde{D}_{21} w(t) + \bar{F}_1 \bar{\xi}_1(t) + \bar{F}_2 \bar{\xi}_2(t) \end{aligned} \quad (29)$$

where

$$\begin{aligned}
\bar{A} &= A + \frac{1}{2}B_2K_u; \quad \bar{B}_2 = [\bar{B}_{21} \quad \bar{B}_{22}]; \quad \bar{B}_{21} = \frac{1}{2}B_2; \\
\bar{B}_{22} &= 0_{n \times g}; \quad \bar{E}_1 = \tilde{E}\bar{Q}(\lambda)^{-1}; \quad \bar{E}_2 = B_2; \\
\bar{C}_1 &= C_1 + \frac{1}{2}D_{12}K_u; \quad M_1 = D_{12}; \quad M_2 = \bar{R}(\lambda)\hat{G}_1; \\
\bar{D}_{12} &= [\bar{D}_{12,1} \quad \bar{D}_{12,2}]; \quad \bar{D}_{12,1} = \frac{1}{2}D_{12}; \quad \bar{D}_{12,2} = 0_{q \times g}; \\
\bar{H}_1 &= \bar{R}(\lambda) \left(\tilde{H} + \frac{1}{2}\hat{G}_1K_u \right); \quad \bar{H}_2 = \frac{1}{2}K_u; \\
\bar{G}_1 &= [\bar{G}_{11} \quad \bar{G}_{12}]; \quad \bar{G}_{11} = \frac{1}{2}\bar{R}(\lambda)\hat{G}_1; \quad \bar{G}_{12} = \bar{R}(\lambda)\hat{G}_2; \\
\bar{G}_2 &= [\bar{G}_{21} \quad \bar{G}_{22}]; \quad \bar{G}_{21} = -\frac{1}{2}I_{m \times m}; \quad \bar{G}_{22} = 0_{m \times g}; \\
\bar{F}_1 &= \tilde{F}\bar{Q}(\lambda)^{-1}; \quad \bar{F}_2 = 0_{(l+g) \times m}; \\
\hat{G}_1 &= \begin{bmatrix} G_1 \\ G_2 \\ 0_{g \times m} \end{bmatrix}; \quad \hat{G}_2 = \begin{bmatrix} 0_{h \times g} \\ 0_{g \times g} \\ I_{g \times g} \end{bmatrix}. \quad (30)
\end{aligned}$$

Also, the IQC (21) is extended to include the additional uncertainty input $\bar{\xi}_2$, that is

$$\int_0^{t_k} \|\bar{\xi}_c(t)\|^2 dt \leq \int_0^{t_k} \|\bar{\zeta}_c(t)\|^2 dt + \bar{d}_c(\lambda) \quad \forall k \quad \forall c = 1, 2. \quad (31)$$

Note that $\bar{\xi}_1(t) = \bar{\xi}(t)$ and $\bar{\zeta}_1(t) = \bar{\zeta}(t)$. Then, two special cases of the uncertainty inputs $\bar{\xi}_2$ are considered.

Case I: $\bar{\xi}_2(t) = \bar{\zeta}_2(t) = \frac{1}{2}K_u x(t) - \frac{1}{2}u(t)$. It is obvious that this uncertainty input satisfies the IQC (31). Also, with this value of $\bar{\xi}_2(t)$, the system (29) will become

$$\begin{aligned}
\dot{x}(t) &= (A + B_2K_u)x(t) + B_1w(t) + \bar{E}_1\bar{\xi}_1(t); \\
z(t) &= (C_1 + D_{12}K_u)x(t); \\
\bar{\zeta}_1(t) &= \bar{R}(\lambda) \left(\tilde{H} + \hat{G}_1K_u \right) x(t) + \bar{R}(\lambda)\hat{G}_2\bar{\nu}(t); \\
\bar{y}(t) &= \bar{C}_2x(t) + \bar{D}_{21}w(t) + \bar{F}_1\bar{\xi}_1(t) \quad (32)
\end{aligned}$$

where the IQC (21) is satisfied. Due to the transformation in (22), the system (32) can be decomposed into

$$\begin{aligned}
\dot{x}(t) &= (A + B_2K_u)x(t) + B_1w(t) + E_1\xi(t) + E_2\mu(t); \\
z(t) &= (C_1 + D_{12}K_u)x(t); \\
\zeta(t) &= (H_1 + G_1K_u)x(t); \\
\nu(t) &= (H_2 + G_2K_u)x(t); \\
y(t) &= C_2x(t) + D_{21}w(t) + F_1\xi(t) + F_2\mu(t); \\
\bar{\nu}(t) &= \bar{\nu}(t); \quad \bar{\mu}(t) = \bar{\mu}(t). \quad (33)
\end{aligned}$$

and it satisfies the IQC (5). In fact, the uncertain system (33), (5) is a closed loop uncertain system obtained when the state feedback controller (26) is applied to the uncertain system (23), (21). Thus, the uncertain system (33), (5) will be absolutely stable with disturbance attenuation γ . It should be noted that the system (33) is not affected by the control input $u(t)$, which is the output of the controller (6).

Case II: $\bar{\xi}_2(t) = -\bar{\zeta}_2(t) = -\frac{1}{2}K_u x(t) + \frac{1}{2}u(t)$. It is obvious that this uncertainty input satisfies the IQC (31).

Using this value of $\bar{\xi}_2(t)$, the system (29) will become

$$\begin{aligned}
\dot{x}(t) &= Ax(t) + B_1w(t) + B_2u(t) + \bar{E}_1\bar{\xi}_1(t); \\
z(t) &= C_1x(t) + D_{12}u(t); \\
\bar{\zeta}_1(t) &= \bar{R}(\lambda) \left(\tilde{H}x(t) + \hat{G}_1u(t) \right) + \bar{R}(\lambda)\hat{G}_2\bar{\nu}(t); \\
\bar{y}(t) &= \bar{C}_2x(t) + \bar{D}_{21}w(t) + \bar{F}_1\bar{\xi}_1(t) \quad (34)
\end{aligned}$$

and the IQC (21) is satisfied. Referring to the transformation in (22), the system (34) can be decomposed into

$$\begin{aligned}
\dot{x}(t) &= Ax(t) + B_1w(t) + B_2u(t) + E_1\xi(t) + E_2\mu(t); \\
z(t) &= C_1x(t) + D_{12}u(t); \\
\zeta(t) &= H_1x(t) + G_1u(t); \\
\nu(t) &= H_2x(t) + G_2u(t); \\
y(t) &= C_2x(t) + D_{21}w(t) + F_1\xi(t) + F_2\mu(t); \\
\bar{\nu}(t) &= \bar{\nu}(t); \quad \bar{\mu}(t) = \bar{\mu}(t). \quad (35)
\end{aligned}$$

It is straightforward to verify that the system (29) reduces to the original system (1).

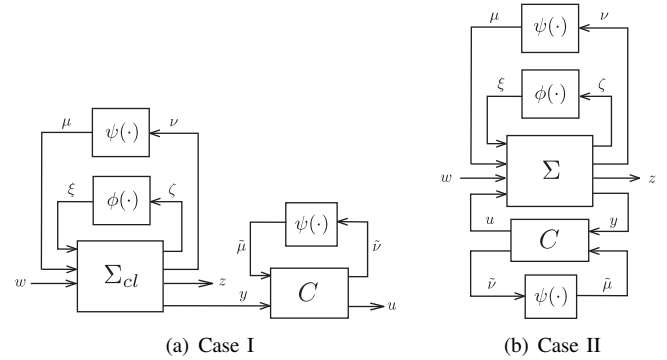

Fig. 3. Block diagrams corresponding to Case I and Case II.

In order to construct the desired controller (6), the results of [18] are applied to the uncertain system (29), (31). If that system is absolutely stabilizable with disturbance attenuation γ via an output feedback controller (6), then it follows from Case I that it is equivalent to the open loop situation (see Fig. 3(a)). Here, the block Σ_{cl} refers to the closed loop uncertain system (33), (5) and the block C refers to the output feedback controller (9). Since the absolute stabilizability with disturbance attenuation γ requires the absolute stability of the entire closed loop system, the output feedback controller (6) must be absolutely stable as well.

Also, it follows from Case II that when the controller (6) is applied to the uncertain system (29), (31), the situation is as shown in Fig. 3(b). Here, the block Σ refers to the original uncertain system (1), (5) and the block C refers to the output feedback controller (6). Therefore, we can conclude that the output feedback controller (6) solves the original problem of absolute stabilizability with disturbance attenuation γ .

Combining the conclusions from both cases, we infer that the output feedback controller (6) obtained by applying the results of [18] to the uncertain system (29), (31) is indeed an absolutely stable output feedback controller which solves

the problem of absolute stabilizability with disturbance attenuation γ for the original nonlinear uncertain system (1), (2), (5). This fact will then lead to our main result involving the solutions of a pair of algebraic Riccati equations.

Then, we rewrite the artificial uncertain system (29) as

$$\begin{aligned}\dot{x}(t) &= \bar{A}x(t) + \hat{B}_1\bar{w}(t) + \hat{B}_2\tilde{u}(t); \\ \bar{z}(t) &= \hat{C}_1x(t) + \hat{D}_{11}\bar{w}(t) + \hat{D}_{12}\tilde{u}(t); \\ \bar{y}(t) &= \tilde{C}_2x(t) + \hat{D}_{21}\bar{w}(t)\end{aligned}\quad (36)$$

where

$$\begin{aligned}\bar{w}(t) &= \begin{bmatrix} \gamma w(t) \\ \sqrt{\tau_1}\xi_1(t) \\ \sqrt{\tau_2}\xi_2(t) \end{bmatrix}; \quad \bar{z}(t) = \begin{bmatrix} z(t) \\ \sqrt{\tau_1}\zeta_1(t) \\ \sqrt{\tau_2}\zeta_2(t) \end{bmatrix}; \\ \hat{B}_1 &= [\gamma^{-1}B_1 \quad \sqrt{\tau_1}^{-1}\bar{E}_1 \quad \sqrt{\tau_2}^{-1}\bar{E}_2]; \\ \hat{C}_1 &= \begin{bmatrix} \bar{C}_1 \\ \sqrt{\tau_1}\bar{H}_1 \\ \sqrt{\tau_2}\bar{H}_2 \end{bmatrix}; \quad \hat{D}_{11} = \begin{bmatrix} 0_{q \times p} & 0_{q \times \bar{r}} & \frac{1}{\sqrt{\tau_2}}M_1 \\ 0_{h \times p} & 0_{h \times \bar{r}} & \sqrt{\frac{\tau_1}{\tau_2}}M_2 \\ 0_{m \times p} & 0_{m \times \bar{r}} & 0_{m \times m} \end{bmatrix}; \\ \hat{D}_{12} &= \begin{bmatrix} \bar{D}_{12,1} & \bar{D}_{12,2} \\ \sqrt{\tau_1}\bar{G}_{11} & \sqrt{\tau_1}\bar{G}_{12} \\ \sqrt{\tau_2}\bar{G}_{21} & \sqrt{\tau_2}\bar{G}_{22} \end{bmatrix}; \quad \hat{B}_2 = [\bar{B}_{21} \quad \bar{B}_{22}]; \\ \hat{D}_{21} &= [\gamma^{-1}\bar{D}_{21} \quad \sqrt{\tau_1}^{-1}\bar{F}_1 \quad \sqrt{\tau_2}^{-1}\bar{F}_2].\end{aligned}\quad (37)$$

Here $\tau_1 > 0$ and $\tau_2 > 0$ are Lagrange multiplier parameters. Due to the \hat{D}_{11} term in (36), the standard H^∞ control theory cannot be directly applied. Thus, it is necessary to apply a loop shifting transformation such that the \hat{D}_{11} term does not appear explicitly in the formulation (e.g., Section 17.2 [20]). First, we define

$$\Phi := I - \hat{D}'_{11}\hat{D}_{11} > 0; \quad \bar{\Phi} := I - \hat{D}'_{11}\hat{D}'_{11} > 0. \quad (38)$$

Then, the state equations (36) can be rewritten as

$$\begin{aligned}\dot{x}(t) &= \check{A}x(t) + \check{B}_1\hat{w}(t) + \check{B}_2\tilde{u}(t); \\ \hat{z}(t) &= \check{C}_1x(t) + \check{D}_{12}\tilde{u}(t); \\ \bar{y}(t) &= \check{C}_2x(t) + \check{D}_{21}\hat{w}(t) + \check{D}_{22}\tilde{u}(t)\end{aligned}\quad (39)$$

where

$$\begin{aligned}\hat{w} &= \Phi^{\frac{1}{2}}\bar{w} - \Phi^{-\frac{1}{2}}\hat{D}'_{11}(\hat{C}_1x + \hat{D}_{12}\tilde{u}); \\ \hat{z} &= \bar{\Phi}^{-\frac{1}{2}}(\hat{C}_1x + \hat{D}_{12}\tilde{u}); \quad \check{A} = \bar{A} + \hat{B}_1\hat{D}'_{11}\bar{\Phi}^{-1}\hat{C}_1; \\ \check{B}_1 &= \hat{B}_1\Phi^{-\frac{1}{2}}; \quad \check{B}_2 = \hat{B}_2 + \hat{B}_1\hat{D}'_{11}\bar{\Phi}^{-1}\hat{D}_{12}; \\ \check{C}_1 &= \bar{\Phi}^{-\frac{1}{2}}\hat{C}_1; \quad \check{C}_2 = \tilde{C}_2 + \hat{D}_{21}\hat{D}'_{11}\bar{\Phi}^{-1}\hat{C}_1; \\ \check{D}_{12} &= \bar{\Phi}^{-\frac{1}{2}}\hat{D}_{12}; \quad \check{D}_{21} = \hat{D}_{21}\bar{\Phi}^{-\frac{1}{2}}; \quad \check{D}_{22} = \hat{D}_{21}\hat{D}'_{11}\bar{\Phi}^{-1}\hat{D}_{12}; \\ \check{J}_1 &= \check{D}'_{12}\check{D}_{12}; \quad \check{J}_2 = \check{D}'_{21}\check{D}_{21}.\end{aligned}$$

The \check{D}_{22} term in (39) will also be eliminated by first defining

$$\bar{y}(t) := \bar{y}(t) - \check{D}_{22}\tilde{u}(t). \quad (40)$$

Hence, the state equations (39) are rewritten as

$$\begin{aligned}\dot{x}(t) &= \check{A}x(t) + \check{B}_1\hat{w}(t) + \check{B}_2\tilde{u}(t); \\ \hat{z}(t) &= \check{C}_1x(t) + \check{D}_{12}\tilde{u}(t); \\ \bar{y}(t) &= \check{C}_2x(t) + \check{D}_{21}\hat{w}(t).\end{aligned}\quad (41)$$

Then, the output feedback controller for (41) is of the form

$$\begin{aligned}\dot{x}_c(t) &= \check{A}_cx_c(t) + \check{B}_c\bar{y}(t); \\ \tilde{u}(t) &= \check{C}_cx_c(t).\end{aligned}\quad (42)$$

and should lead to the H^∞ norm bound condition

$$\hat{\mathcal{J}} := \sup_{\hat{w}(\cdot) \in \mathbf{L}_2[0, \infty), x(0)=0, x_c(0)=0} \frac{\|\hat{z}(\cdot)\|_2^2}{\|\hat{w}(\cdot)\|_2^2} < 1. \quad (43)$$

The coefficient matrices of (42) involve the solutions of the Riccati equations, which are defined as follows: Let $\tau_1 > 0$ and $\tau_2 > 0$ be given constants. Also, suppose that $\check{J}_1 > 0$ and $\check{J}_2 > 0$. Then, $\check{X} > 0$ and $\check{Y} > 0$ are the stabilizing solutions of the following Riccati equations (see [19])

$$\begin{aligned}(\check{A} - \check{B}_2\check{J}_1^{-1}\check{D}'_{12}\check{C}_1)' \check{X} + \check{X} (\check{A} - \check{B}_2\check{J}_1^{-1}\check{D}'_{12}\check{C}_1) \\ + \check{X} (\check{B}_1\check{B}'_1 - \check{B}_2\check{J}_1^{-1}\check{B}'_2) \check{X} \\ + \check{C}'_1 (I - \check{D}_{12}\check{J}_1^{-1}\check{D}'_{12}) \check{C}_1 = 0;\end{aligned}\quad (44)$$

$$\begin{aligned}(\check{A} - \check{B}_1\check{D}'_{21}\check{J}_2^{-1}\check{C}_2)' \check{Y} + \check{Y} (\check{A} - \check{B}_1\check{D}'_{21}\check{J}_2^{-1}\check{C}_2) \\ + \check{Y} (\check{C}'_1\check{C}_1 - \check{C}'_2\check{J}_2^{-1}\check{C}_2) \check{Y} \\ + \check{B}_1 (I - \check{D}'_{21}\check{J}_2^{-1}\check{D}_{21}) \check{B}'_1 = 0\end{aligned}\quad (45)$$

such that the spectral radius of the product $\check{X}\check{Y}$ satisfies $\rho(\check{X}\check{Y}) < 1$. Thus, the desired controller matrices are given in the following theorem.

Theorem 1: Suppose that $\lambda \in \tilde{\Lambda}$, $J > 0$ and there exists a constant $\kappa > 0$ such that the Riccati equation (28) has a stabilizing solution $X > 0$ and hence

$$K = -J^{-1}(\check{B}'_2X + \check{D}'_{12}\check{C}_1).$$

Also, suppose that $\hat{D}_{11}\hat{D}'_{11} < I$, $\check{J}_1 > 0$, $\check{J}_2 > 0$ and there exist constants $\tau_1 > 0$ and $\tau_2 > 0$ such that both Riccati equations (44) and (45) have stabilizing solutions $\check{X} > 0$ and $\check{Y} > 0$, and the spectral radius of the product $\check{X}\check{Y}$ satisfies $\rho(\check{X}\check{Y}) < 1$. Then the nonlinear uncertain system (1), (2), (5) is absolutely stabilizable with disturbance attenuation γ via a stable nonlinear output feedback controller (6). Moreover, the controller matrices are given as follows

$$\begin{aligned}A_c &= \check{A}_c - \check{B}_c\check{D}_{22}\check{C}_c; \\ \check{A}_c &= \check{A} + \check{B}_2\check{C}_c - \check{B}_c\check{C}_2 + (\check{B}_1 - \check{B}_c\check{D}_{21})\check{B}'_1\check{X}; \\ \check{B}_c &= [B_c \quad B_c^\mu] = (I - \check{Y}\check{X})^{-1}(\check{Y}\check{C}'_2 + \check{B}_1\check{D}'_{21})\check{J}_2^{-1}; \\ \check{C}_c &= \begin{bmatrix} C_{c1} \\ C_{c\bar{v}} \end{bmatrix} = -\check{J}_1^{-1}(\check{B}'_2\check{X} + \check{D}'_{12}\check{C}_1).\end{aligned}\quad (46)$$

Proof: Following a similar argument as in the proof of Theorem 4.1 in [18], the nonlinear uncertain system (1), (2), (5) is absolutely stabilizable with disturbance attenuation level γ via a controller of the form (6) if and only if there exist constants $\tau_1 > 0$ and $\tau_2 > 0$ such that the controller (42) solves the H^∞ control problem defined by (41) and (43). Moreover, it follows from the standard results of H^∞ control theory (e.g., see [20]) that the H^∞ control problem

defined by (41) and (43) has a solution if and only if the Riccati equations (44) and (45) have stabilizing solutions $\check{X} \geq 0$ and $\check{Y} \geq 0$, respectively, such that the spectral radius of the product $\check{X}\check{Y}$ satisfies $\rho(\check{X}\check{Y}) < 1$.

If all the conditions of the theorem hold, then the controller (42), (46) is absolutely stabilizing with disturbance attenuation level γ for the uncertain system (29), (31). Then, from the arguments in the two special cases above, it follows that the controller (42), (46) absolutely stabilizes the nonlinear uncertain system (1), (2), (5) with disturbance attenuation level γ and it is indeed a stable controller. ■

Remark 1: In the case in which the dimension of the parameter vector λ is large, an optimization method may be required to choose the parameters λ , κ , τ_1 and τ_2 .

IV. CONCLUSIONS

A method to design a stable nonlinear output feedback controller has been presented in this paper. This method solves the nonlinear robust H^∞ control problem for a class of nonlinear uncertain systems described by Integral Quadratic Constraints (IQCs) and Global Lipschitz Condition (GLC). The main ideas are to include a copy of the plant nonlinearity in the controller and then to characterize the nonlinearity and its copy by extra IQCs derived from the GLC. This approach enables the nonlinear controller to exploit the nonlinearity in the system being controlled.

The desired controller is synthesized based on existing results of robust H^∞ control theory applied to an artificial uncertain system. This system is constructed by adding an artificial uncertainty, defined using a state feedback gain matrix, to the original nonlinear uncertain system. Then, the controller is constructed using the stabilizing solutions of H^∞ -type algebraic Riccati equations and solves the absolute stabilization problem with a disturbance attenuation level γ .

REFERENCES

- [1] M. Zeren and H. Özbay, "On the synthesis of stable H^∞ controllers," *IEEE Transactions on Automatic Control*, vol. 44, no. 2, pp. 431–435, 1999.
- [2] D. U. Campos-Delgado and K. Zhou, " H^∞ strong stabilization," *IEEE Transactions on Automatic Control*, vol. 46, no. 12, pp. 1968–1972, 2001.
- [3] A.-W. A. Saif, D.-W. Gu, and I. Postlethwaite, "Strong stabilization of MIMO systems via H^∞ optimization," *Systems and Control Letters*, vol. 32, no. 2, pp. 111–120, 1997.
- [4] D. C. Youla, J. J. Bongiorno, and C. N. Lu, "Single-loop feedback-stabilization of linear multivariable dynamical plants," *Automatica*, vol. 10, no. 2, pp. 159–173, 1974.
- [5] M. Vidyasagar, *Control System Synthesis: A Factorization Approach*. Cambridge, MA: MIT Press, 1985.
- [6] M. Zeren and H. Özbay, "On the strong stabilization and stable H^∞ -controller design problems for MIMO systems," *Automatica*, vol. 36, no. 11, pp. 1675–1684, 2000.
- [7] Y.-S. Chou, T.-Z. Wu, and J.-L. Leu, "On strong stabilization and H^∞ strong stabilization problems," in *Proceedings of the 42nd IEEE Conference on Decision and Control*, Maui, Hawaii, USA, December 2003, pp. 5155–5160.
- [8] J. W. Helton and M. R. James, *A General Framework for Extending H^∞ Control to Nonlinear Systems*. Philadelphia: SIAM, 1999.
- [9] R. Sepulchre, M. Janković, and P. Kokotović, *Constructive Nonlinear Control*. London: Springer, 1997.
- [10] P. Kokotović and M. Arcak, "Constructive nonlinear control: a historical perspective," *Automatica*, vol. 37, no. 5, pp. 637–662, 2001.
- [11] M. Arcak, M. Larsen, and P. Kokotović, "Circle and popov criteria as tools for nonlinear feedback design," *Automatica*, vol. 39, no. 4, pp. 643–650, 2003.
- [12] A. J. Shaiju and I. R. Petersen, "Discrete time robust H^∞ control of a class of nonlinear uncertain systems," in *Proceedings of 17th IFAC World Congress*, Seoul, South Korea, 6 - 11 July 2008.
- [13] I. R. Petersen, "Robust H^∞ control of an uncertain system via a stable output feedback controller," in *American Control Conference*, Minneapolis, Minnesota, USA, June 2006.
- [14] I. R. Petersen, V. A. Ugrinovskii, and A. V. Savkin, *Robust Control Design using H^∞ Methods*. Springer-Verlag London, 2000.
- [15] I. R. Petersen, "Robust output feedback guaranteed cost control of nonlinear stochastic uncertain systems via an IQC approach," in *American Control Conference*, Minneapolis, Minnesota, USA, June 2006.
- [16] M. Arcak and P. Kokotović, "Observer-based control of systems with slope-restricted nonlinearities," *IEEE Transactions on Automatic Control*, vol. 46, no. 7, pp. 1146–1150, 2001.
- [17] A. Packard, "Gain scheduling via linear fractional transformations," *Systems and Control Letters*, vol. 22, no. 2, pp. 79–92, 1994.
- [18] A. V. Savkin and I. R. Petersen, "Robust H^∞ control of uncertain systems with structured uncertainty," *Journal of Mathematical Systems, Estimation and Control*, vol. 6, no. 4, pp. 339–342, 1996.
- [19] I. R. Petersen, B. D. O. Anderson, and E. A. Jonckheere, "A first principles solution to the non-singular H^∞ control problem," *International Journal of Robust and Nonlinear Control*, vol. 1, no. 3, pp. 171–185, 1991.
- [20] K. Zhou, J. Doyle, and K. Glover, *Robust and Optimal Control*. Upper Saddle River, NJ, USA: Prentice-Hall, 1996.