

# Robust Optimization for Strategic Energy Planning

Stefano MORET<sup>1\*</sup>, Michel BIERLAIRE<sup>2</sup>, François MARÉCHAL<sup>1</sup>

<sup>1</sup>*Industrial Process and Energy Systems Engineering Group (IPESE)*

<sup>2</sup>*Transport and Mobility Laboratory*

*École Polytechnique Fédérale de Lausanne*

*1015 Lausanne, Switzerland*

*e-mail: stefano.moret@epfl.ch*

Received: November 2014; accepted: November 2015

**Abstract.** Long-term planning for energy systems is often based on deterministic economic optimization and forecasts of fuel prices. When fuel price evolution is underestimated, the consequence is a low penetration of renewables and more efficient technologies in favour of fossil alternatives. This work aims at overcoming this issue by assessing the impact of uncertainty on energy planning decisions.

A characterization of uncertainty in energy systems decision-making is performed. Robust optimization is then applied to a Mixed-Integer Linear Programming problem, representing the typical trade-offs in energy planning. It is shown that in the uncertain domain investing in more efficient and cleaner technologies can be economically optimal.

**Key words:** energy planning, robust optimization, uncertainty characterization, Mixed-Integer Linear Programming.

## 1. Introduction

Extrapolating current trends to 2050, global energy demand is expected to increase by 70% compared with 2011 mainly due to the growth of non-OECD countries. As a consequence, greenhouse gas emissions would be 60% higher compared with 2011, with catastrophic effects related to climate change. Policies to limit the expected increase in global temperatures to a 2 °C threshold show the need to reduce the increase in energy demand to 25% and to radically cut emissions by 50%. Reaching these ambitious goals implies strategic decisions to be made for energy systems, fostering energy efficiency while gradually replacing fossil technologies with renewables and more efficient alternatives (IEA, 2014).

### 1.1. Motivation

Long-term energy planning is a strategic decision-making process. In the context of this work, it involves the selection, sizing and operation of energy conversion technologies. Due to the typical lifetime of these technologies, the time horizon of energy planning is usually 20–50 years. The decision-making approach often involves modelling the evolution of the energy system over time. In most cases this requires forecasting modelling

---

\* Corresponding author.

efforts, justified by the principle that taking a decision would be immediate if the future was known.

Koomey *et al.* (2003) reviewed the available retrospectives on long-term energy models, underlining the often forgotten importance of model backcasting to learn from previous errors. Their conclusion is that long term energy models are inevitably inaccurate as they miss pivotal events. They recommend learning from the past in order to create better and more useful models for the future. Furthermore, adopting the classification by Hodges and Dewar (1992), they define energy models as “nonvalidatable”, i.e. doomed to inaccuracy. This is because energy systems are often not observable and measurable, do not exhibit constancy of structure in time, do not exhibit constancy across variations in conditions not specified in the model and do not permit the collection of ample data.

A particular subset within energy forecasting is the modelling of fossil fuels availability and price over time. Siddiqui and Marnay (2006) highlight how U.S. natural gas generation costs over the period 1975 to 2006 have been characterized by two clear regime switches, which are inherently unpredictable. They also compare the forecasts by the Annual Energy Outlook (AEO) of the Energy Information Administration (EIA) with the actual wellhead gas prices, exposing error factors in predictions as high as 3.6. Krugman (2013) has recently revisited the pioneering work by Nordhaus (1973) in the field of long-term econometric modelling of energy systems, finding that pivotal events have dramatically changed the course of history, and price forecasts are quite divergent from predictions.

Some important energy models (NEMS (NEMS, 2003), MARKAL-TIMES (Fishbone and Abilock, 1981), META\*Net (Lamont, 2008)) have been improved over time to include uncertainties. Nonetheless, Siddiqui and Marnay (2006) point out how sometimes the formalism of the resulting stochastic models hides a very poor knowledge of the distribution parameters. They also point out that in these models, which are very complex and based on economic optimization, the high uncertainty on key parameters (mainly economic) might be greater than the modelling resolution.

When forecasts underestimate the evolution of fuel prices, the consequence is a low penetration of renewables and more efficient technologies in favour of established fossil-based ones. Also, errors in forecasts often lead to overcapacity and sub-utilization of the installed technologies. This is the current case with natural gas fired Combined Cycle power plants overcapacity in Europe (COGEN Europe, 2014). As deterministic forecasting models have generally performed poorly, various authors now agree that taking uncertainty into account in energy systems planning and design, as well as in other disciplines, is a priority (de Neufville, 2013), and this represents the key motivation of this work.

## 1.2. Key Challenges

Soroudi and Amraee (2013) reviewed the various approaches to address the problem of energy planning under uncertainty. Zhou *et al.* (2006) performed a complementary review mostly focused on Decision Analysis types of methods. The key gaps identified in literature are:

- Uncertainty characterization: a methodology is needed to assess type and degree of uncertainty for each parameter. The output of the uncertainty characterization is the definition of ranges of variation or Probability Density Functions (PDFs) for each uncertain parameter.
- Methodology: various methods have been developed in literature for optimization under uncertainty. A general methodology needs to be defined.
- Energy system applications: most methods are only applied to small subsystems or to the operation of the electricity sector. It is central to focus on a system view of the problem, including heating and transportation.

### 1.3. Goals and Approach

The focus of this work is mainly on parameter uncertainty. Model uncertainty, dealing with the ability of the model to represent reality, is not treated due to the classification of energy models as “non-validatable”. The goals and innovative aspects of this work are based on the previously identified gaps:

- A set of criteria is applied to define ranges of variation for the uncertain parameters. This is a step towards the definition of a general uncertainty characterization methodology.
- The classical way of treating uncertainties in optimization uses probability distributions (Morgan, 2009), however in many cases it is difficult (and possibly misleading) to associate a PDF to a parameter when the PDF is unknown (Siddiqui and Marnay, 2006). Therefore, robust optimization is chosen as it only requires the definition of ranges of variation for the parameters. More specifically, the robust approach developed by Bertsimas and Sim (2004) is adopted. Compared to other robust optimization methods, this approach presents the advantage of linearity in the robust counterpart of a MILP problem. To the authors’ knowledge, it is applied here for the first time to a strategic energy system planning problem.
- Despite the importance of accounting for uncertainties, the impact of techniques for optimization under uncertainty at the level of applications in the energy field has been limited due to modelling and computational barriers (Grossmann *et al.*, 2015). The presented method is a step towards overcoming these barriers as it can be easily applied to already existing Mixed-Integer Linear Programming (MILP) models and it is not computationally expensive.

Cleaner and efficient technologies represent the optimal choice when the objective is emissions or resources consumption, while high investment cost is the key barrier to their wider diffusion. Thus, the interest of this work is understanding how uncertainty impacts energy planning problems having cost minimization as objective.

Firstly, a specific literature review covers previous efforts in uncertainty characterization and robust optimization applied to energy planning problems. An example MILP problem is developed, showing typical trade-offs in energy planning, easily adaptable to urban or national energy system cases. Ranges of variation for the uncertain parameters are identified and used as input for a Global Sensitivity Analysis (GSA). This allows for factor fixing, i.e. defining priorities for treating uncertainty in the optimization by separating

influential from non-influential parameters. Robust optimization is applied to the MILP problem and relevant results are discussed. The work is completed by a post-sensitivity analysis, conclusions and identification of the next steps.

## 2. Literature Review

The succinct literature review has the goal of covering previous efforts in uncertainty characterization and in robust optimization applied to energy planning problems.

### 2.1. Uncertainty Characterization

Soroudi and Amraee (2013) make a distinction between technical and economic uncertain parameters: technical parameters are mostly related to the electricity market and economic parameters are divided into micro- and macro-economic ones. Løken *et al.* (2006) differentiate between external and internal uncertainties. They focus on external uncertainties, dividing them into three categories: physical, economic and regulatory. Internal uncertainties are related to the decision-maker. They introduce the distinction between non-quantifiable and quantifiable uncertainties: the first can be treated with sensitivity or scenario analysis and can be ranked by non-stochastic decision criteria (dominance, maximax, maximin or minimax regret), while the second ones can be approached with stochastic criteria (expected value). Dubuis (2012) introduces a structured classification of uncertainties, mainly related to energy system design and operation.

These efforts are mainly focused on a classification of uncertainty by type. To date, a general methodology for uncertainty characterization, assessing parameter uncertainty by type and degree (in terms of range of variation or PDFs) is missing.

### 2.2. Robust Optimization

The theory and methodology of robust optimization are discussed in Section 5. Soroudi and Amraee (2013) have reviewed applications of robust optimization to energy decision-making under uncertainty. The key applications of interest are: Plug-in Hybrid Electric Vehicles (long-term planning), unit commitment problems for electricity generation, demand-side management and electricity market.

As highlighted in the review, most applications are focused on short-term unit commitment problems, while the present paper focuses on long-term energy planning.

## 3. Optimization Model

Long-term energy planning models are often formulated as MILP problems (Koltsaklis *et al.*, 2014). The methodology presented in this work applies to this class of optimization models. A MILP problem is developed accounting for typical trade-offs in energy planning in order to exemplify step-by-step the application of the proposed methodology. The conceptual structure of this example model is easily adaptable to more complex urban and national energy planning problems.

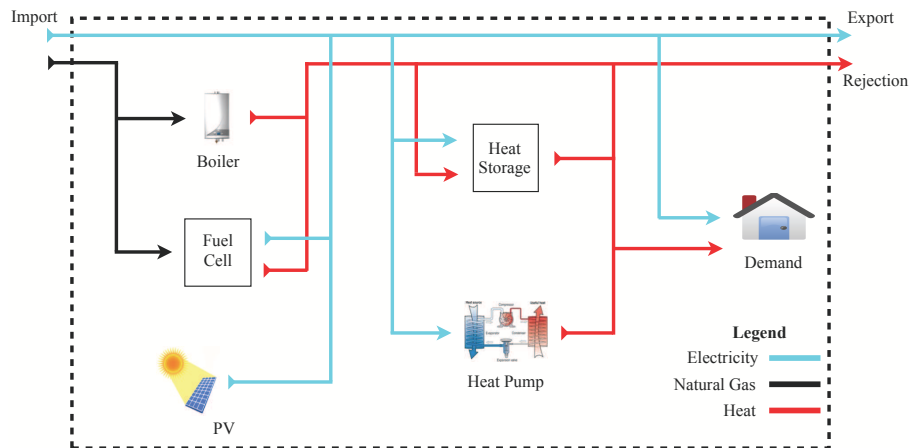

Fig. 1. Example optimization model: technology choice for household energy supply. Model superstructure showing input-output of the different technology options and the energy system configuration.

### 3.1. Example MILP Model Description

The example model, shown in Fig. 1, compares different technology options for supplying heat and electricity to a Single Family Household (SFH). The goal of the optimization is investment decision-making (technology choice and sizing). The key assumptions and characteristics of the model are the following:

- Multi-period problem: the year is split into 12 periods for the different months, and one additional peak period for design.
- Household demand: yearly data for heating and electricity demand are for a SIA 380/1 standard compliant SFH in Switzerland (Dorer *et al.*, 2005).
- Technology options: five technologies are available, with corresponding parameters detailed in Section 3.2.
- As monthly power averages are considered, it is assumed for photovoltaics that daily and weekly fluctuations are managed by the integration in the electricity grid.

The optimization problem is written in AMPL (Fourer *et al.*, 2002). The problem formulation is detailed in the following subsections defining sets, parameters, constraints and the objective function.

### 3.2. Sets, Parameters, Variables, Constraints

The following sets are defined:

- UNITS  $u = \{1, \dots, U\} = \{BOIL, FC, STO, PV, HP\}$ : natural gas Boiler, Fuel Cell, Heat Storage, Photovoltaic panel, Heat Pump, respectively.
- PERIODS  $t = \{1, \dots, T\} = \{1, \dots, 13\}$ .

Table 1 lists the parameters defined in the optimization model. The default values used for the parameters are detailed in the corresponding tables in Appendix A.

Table 1  
Parameter list with description.

Parameter	Units	Description	Value
$c_{ng}(t)$	[CHF/kWh]	Cost of natural gas (ng)	Table 6
$c_{el, buy}(t)$	[CHF/kWh]	Cost of importing electricity	Table 6
$c_{el, sell}(t)^a$	[CHF/kWh]	Price of selling electricity	Table 6
$f_{min}(u), f_{max}(u)$	[-]	Lower/upper bound for units size	Table 5
$C_{inv,1}(u), C_{inv,2}(u)$	[CHF]	Linear coefficients for investment cost	Table 5
$\dot{E}_{out,ref}(u)$	[kW]	Reference electrical power output	Table 5
$\dot{Q}_{out,ref}(u)$	[kW] <sup>b</sup>	Reference thermal power output	Table 5
$\dot{E}_{demand}(t)$	[kW]	Household electricity demand	Table 6
$\dot{Q}_{demand}(t)$	[kW]	Household heat demand	Table 6
$t_{op}(t)$	[h]	Period duration	Table 6
$i$	[-]	Interest rate	0.05
$n$	[years]	Lifetime	20
$c_p(u, t)$	[-]	Capacity factor	Table 7
$\varepsilon_{el}(u)$	[-]	Units electrical efficiency	Table 5
$\varepsilon_{th}(u)$	[-]	Units thermal efficiency	Table 5
$t_{STO, discharge}$	[h <sup>-1</sup> ]	Storage full discharge time constant	672 <sup>-1</sup>

<sup>a</sup> Assumed to be 40% of the nominal value of  $c_{el, buy}(t)$ .

<sup>b</sup> [kWh] of thermal energy for the storage unit.

Table 2  
Variable list with description. All variables are continuous and non-negative, unless otherwise indicated.

Variable	Units	Description
$y(u) \in \{0, 1\}$	[-]	Binary variable, investment decision for the unit
$f(u, t)$	[-]	Multiplication factor, operation of the unit
$f_{c_p}(u, t)$	[-]	Multiplication factor taking into account the $c_p$
$C_{inv}(u)$	[CHF]	Linearized unit investment cost
$\dot{E}_{in}(u, t), \dot{E}_{out}(u, t)$	[kW]	Electrical power in/out for each unit
$\dot{Q}_{in}(u, t), \dot{Q}_{out}(u, t)$	[kW]	Thermal power in/out for each unit
$\dot{E}_{buy}(t)$	[kW]	Electrical power imported
$\dot{E}_{sell}(t)$	[kW]	Electrical power sold
$\dot{Q}_{ng}(u, t)$	[kW]	Natural gas imported
$\dot{Q}_{rej}(t)$	[kW]	Thermal power rejected by the system
$f_{size}(u)$	[-]	Multiplication factor for unit installed capacity
$\tau$	[-]	Annualization factor for investment cost
$STO_{level}(t)$	[kWh]	Thermal energy level in the storage unit

Table 2 lists the variables of the optimization model.

The unit multiplication factor  $f(u, t)$  is related to the operation of the units and defines how much a unit is actually used in each period. The variable  $f_{size}$  defines the size of the unit (installed capacity). It is defined as the maximum value of the multiplication factor over the different periods:

$$f(u, t) \leq f_{size}(u) \quad \forall u \in \{BOIL, HP, PV, FC\}, \quad \forall t. \quad (1)$$

$y(u)$  is the binary variable related to the investment choice for each unit. If  $y(u) = 1$  the unit is purchased, if  $y(u) = 0$  the unit is not purchased. The size of each unit is limited by the parameters  $f_{\min}(u)$  and  $f_{\max}(u)$ , the lower and upper bound, respectively. The size of the unit is equal to zero if the unit is not purchased, i.e. if  $y(u) = 0$ :

$$f_{\min}(u) \cdot y(u) \leq f_{\text{size}}(u) \leq f_{\max}(u) \cdot y(u) \quad \forall u. \quad (2)$$

The investment cost  $C_{\text{inv}}(u)$  is linearized as the summation of two components: the fixed cost  $C_{\text{inv},1}$ , activated if the unit is purchased, and the variable cost  $C_{\text{inv},2}$ , associated to the size of the unit:

$$C_{\text{inv}}(u) = C_{\text{inv},1}(u) \cdot y(u) + f_{\text{size}}(u) \cdot C_{\text{inv},2}(u) \quad \forall u. \quad (3)$$

The unit multiplication factor is multiplied by the capacity factor  $c_p$ , defined as the ratio between the maximum feasible average power output for each month and the nominal unit size.  $f_{c_p}$  is the adjusted multiplication factor which takes into account the capacity factor of each unit:

$$f_{c_p}(u, t) = f(u, t) \cdot c_p(u, t) \quad \forall u, t. \quad (4)$$

$\dot{E}_{\text{out}}(u, t)$  and  $\dot{Q}_{\text{out}}(u, t)$  are respectively the electrical and thermal power outputs for each unit and each period. They are calculated by multiplying the respective reference values  $\dot{E}_{\text{out},\text{ref}}(u)$  and  $\dot{Q}_{\text{out},\text{ref}}(u)$  by the multiplication factor. Cogeneration units as the Fuel Cell, producing both heat and electricity, and storage units need the definition of specific equations (Section 3.2.1):

$$\begin{aligned} \dot{E}_{\text{out}}(u, t) &= \dot{E}_{\text{out},\text{ref}}(u) \cdot f_{c_p}(u, t) \quad \forall u, t, \\ \dot{Q}_{\text{out}}(u, t) &= \dot{Q}_{\text{out},\text{ref}}(u) \cdot f_{c_p}(u, t) \quad \forall u \in \{BOIL, HP, PV\}, \forall t. \end{aligned} \quad (5)$$

The following two constraints express respectively the energy balance for electricity and heat.

The household electricity demand  $\dot{E}_{\text{demand}}(t)$  and the units electricity demand  $\dot{E}_{\text{in}}(u, t)$  are satisfied by the production of electricity inside the system  $\dot{E}_{\text{out}}(u, t)$  and by the electricity imports  $\dot{E}_{\text{buy}}(t)$ .  $\dot{E}_{\text{sell}}(t)$  is the excess electricity production which is sold outside the system boundaries:

$$\dot{E}_{\text{buy}}(t) + \sum_u \dot{E}_{\text{out}}(u, t) - \sum_u \dot{E}_{\text{in}}(u, t) - \dot{E}_{\text{demand}}(t) - \dot{E}_{\text{sell}}(t) = 0 \quad \forall t. \quad (6)$$

In the same way, the household heat demand  $\dot{Q}_{\text{demand}}(t)$  and units heat demand  $\dot{Q}_{\text{in}}(u, t)$  are satisfied by the production of heat inside the system  $\dot{Q}_{\text{out}}(u, t)$ .  $\dot{Q}_{\text{rej}}(t)$  is the excess heat rejected from the system:

$$\sum_u \dot{Q}_{\text{out}}(u, t) - \sum_u \dot{Q}_{\text{in}}(u, t) - \dot{Q}_{\text{demand}}(t) - \dot{Q}_{\text{rej}}(t) = 0 \quad \forall t. \quad (7)$$

The investment cost annualization factor  $\tau$  is a function of the unit lifetime  $n$  (assumed equal for all units) and of the interest rate  $i$ :

$$\tau = \frac{i(i+1)^n}{(1+i)^n - 1}. \quad (8)$$

The possibility of importing electricity during the peak period is limited in order to avoid obtaining unrealistically small sizes for the various technologies.  $\dot{E}_{buy}(13)$  is limited to 6 kW, but this limit is reduced to 2 kW if other units producing electricity (PV and FC) are selected. If the HP is chosen, the limit is increased by 1 kW in order to satisfy the consequent additional electricity demand. Eq. (9) is expressed in a compact quadratic formulation but can easily be linearized.

$$E_{buy}(13) \leq 2 + y(HP) + 4(1 - y(PV))(1 - y(FC)). \quad (9)$$

### 3.2.1. Unit Specific Constraints

Additional equations are needed to calculate the consumption of natural gas  $\dot{Q}_{ng}(u, t)$  and electricity  $\dot{E}_{in}(u, t)$  for some units. The ratio between energy input and output for each unit is expressed by the electrical efficiency  $\varepsilon_{el}(u)$  and the thermal efficiency  $\varepsilon_{th}(u)$ .

$$\begin{aligned} \dot{Q}_{ng}(BOIL, t) &= \frac{\dot{Q}_{out}(BOIL, t)}{\varepsilon_{th}(BOIL)} \quad \forall t, \\ \dot{Q}_{ng}(FC, t) &= \frac{\dot{E}_{out}(FC, t)}{\varepsilon_{el}(FC)} \quad \forall t, \\ \dot{E}_{in}(HP, t) &= \frac{\dot{Q}_{out}(HP, t)}{\varepsilon_{th}(HP)} \quad \forall t. \end{aligned} \quad (10)$$

The thermal power output of the cogeneration unit (Fuel Cell) is calculated in the same way:

$$\dot{Q}_{out}(FC, t) = \dot{Q}_{ng}(FC, t) \cdot \varepsilon_{th}(FC) \quad \forall t. \quad (11)$$

The storage is modelled in a simplified way. The amount of heat stored in the unit is expressed by  $STO_{level}(t)$ . The level can be increased over the different periods by inputs of heat and electricity, and decreased by the heat outputs (Eq. (12)). For this unit, the size is calculated based on the maximum value of  $STO_{level}(t)$  over the different periods (Eq. (13)). An additional equation makes sure that the storage is not used to cover the peak period demand but has a seasonal behaviour. This is achieved with the definition of a time constant for the full discharge of the storage tank (Eq. (13)).

$$\begin{aligned} STO_{level}(t) &= STO_{level}(t-1) \\ &+ (\dot{E}_{in}(STO, t) + \dot{Q}_{in}(STO, t) - \dot{Q}_{out}(STO, t)) \cdot t_{op}(t) \quad \forall t, \end{aligned} \quad (12)$$



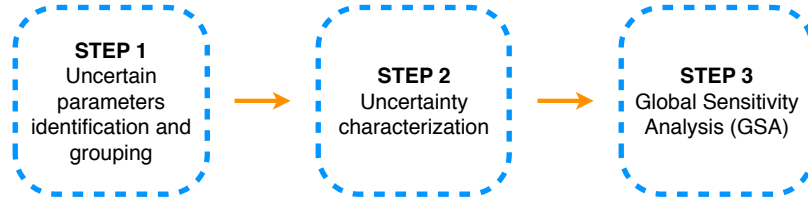

Fig. 2. Factor fixing steps.

$$STO_{level}(t) \leq \dot{Q}_{out,ref}(STO) \cdot f_{size}(STO) \quad \forall t, \quad (13)$$

$$\dot{Q}_{out}(STO, t) \leq \dot{Q}_{out,ref}(STO) \cdot f_{size}(STO) \cdot t_{STO,discharge} \quad \forall t. \quad (14)$$

### 3.3. Objective Function

The objective is the minimization of the total annual cost of the energy system, the sum of the annualized investment cost and the operating cost. The operating cost is the difference between the cost of purchasing natural gas and electricity at their respective costs  $c_{ng}(t)$  and  $c_{el,buy}(t)$ , and the profits generated by selling electricity at the price  $c_{el,sell}(t)$ . The multiplication by  $t_{op}(t)$ , the hours of duration of each period, allows the conversion from power to energy units.

$$\min \left( \tau \sum_u C_{inv}(u) + \sum_t \left( \sum_u c_{ng}(t) \dot{Q}_{ng}(u, t) + c_{el,buy}(t) \dot{E}_{buy}(t) - c_{el,sell}(t) \dot{E}_{sell}(t) \right) \cdot t_{op}(t) \right). \quad (15)$$

## 4. Factor Fixing

Various authors have used sensitivity analysis for ranking the influence of uncertain parameters in energy planning problems (Hajimiragha *et al.*, 2011; Pernet, 2014). Sensitivity analysis requires, as an input, the definition of PDFs or ranges of variation for the uncertain parameters. In the authors' view, uncertainty characterization should serve for this purpose.

Factor fixing has the goal of defining priorities for treating uncertain parameters in the optimization, allowing separation of influential and non-influential parameters. An application in three steps is proposed in this work, as illustrated in Fig. 2. Firstly, uncertain parameters are identified and grouped in order to reduce their number. The second step is the application of a set of criteria to characterize parameter uncertainty in terms of ranges of variation. The third step is the GSA, which ranks the parameters according to their effect on the outputs of interest. As an example, factor fixing is applied step-by-step to the MILP model defined in Section 3.

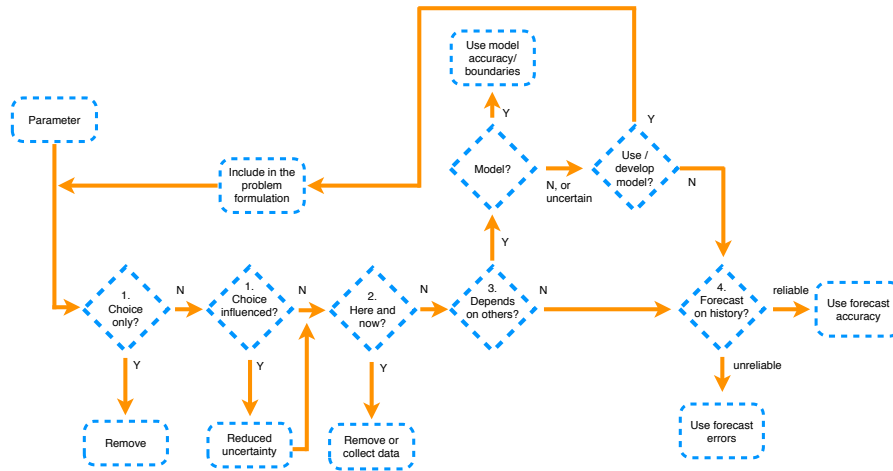

Fig. 3. Sequential application of criteria for uncertainty characterization (Step 2).

#### 4.1. Parameters Identification and Grouping

The first step is the identification of all the parameters in the model. According to the list in Table 1, the model has 186 parameters. Some of these parameters do not present any uncertainty, e.g. the period duration  $t_{op}(t)$ . Others can be assumptions made by the modeller, such as the  $c_p$  of all units except HP and PV. This is because the latter two depend respectively on the external temperature and on the solar irradiation.

The other parameters are grouped in order to reduce their number. For multi-period parameters an uncertain multiplication factor is defined. For example, the 13 parameters  $\dot{Q}_{demand}(t)$  are grouped by  $\dot{Q}_{demand,mult}$ . This reduces the number of uncertain parameters to 16, which are listed in Table 3.

#### 4.2. Uncertainty Characterization

The goal of the uncertainty characterization step is the definition of ranges of variation for the uncertain parameters. For each of the identified uncertain parameters a set of sequential criteria is applied. The idea behind this procedure is that parameter uncertainty can vary based on who the Decision-Maker (DM) is and the conditions in which the decisions are taken.

The sequential criteria, depicted in Fig. 3, are the following:

1. *Does the parameter depend only on a choice made by the Decision Maker (DM)?* A parameter can depend only on choices made by the decision-maker, e.g. fuel taxation when the DM is the government. In this case, it is not uncertain, and it can be defined as a decision variable instead. If the parameter partially depends on a choice made by the DM, e.g. the implementation of an energy policy by the government, information concerning the choice can reduce the parameter uncertainty.

2. *Is it a here-and-now parameter?* In some cases the uncertain parameter is known at the moment in which the decision is made. In this case the uncertainty is eliminated, or data can be collected to assess ranges of variation or PDFs.
3. *Does the parameter depend on other parameters?* If the uncertain parameter depends on other parameters, a model or mathematical relation might be available. If the additional parameters are not uncertain, the accuracy of this model can be used to define the ranges of variation or PDFs (e.g. a thermodynamic model for the energy efficiency). If the additional parameters are uncertain, the model can be embedded within the problem formulation. If the model is not available, a new model can be developed. In both cases, the additional parameters become the new uncertain parameters to be characterized.
4. *Can forecasts be made on historical data?* If there is no further dependency for the parameters, or the option of using or developing a model is not chosen, forecasts based on historical data might be available. Depending on the reliability of these forecasts, references on their accuracy can be used to define ranges of variation or PDFs.

#### 4.2.1. Application to the Example MILP Problem

Uncertainty characterization is applied to the example MILP model with the goal of defining ranges of variation for the uncertain parameters. Results of the analysis are summarized in Table 3, which shows which of the criteria are applied and the consequent range of variation for each parameter. The range of variation is taken from references when available. When references are not available, a  $\pm 5\%$  variation is assumed for parameters with a low degree of uncertainty,  $\pm 10\%$  for a medium degree of uncertainty. The choice of these values is based on the modeller's expert judgement and applies only to this specific example. For defining ranges of variations, values typical of a large scale energy system are considered.

The following considerations hold for the uncertain parameters:

- The interest rate  $i$  has low uncertainty as it depends on a choice and on the *here-and-now* financial conditions of the DM.
- The electrical efficiency of the Fuel Cell  $\varepsilon_{el}(FC)$  can vary substantially based on the Fuel Cell type. Once the type is chosen, thermodynamic models can be used to set the boundaries. As fuel cells are not a mature technology, a medium uncertainty is considered.
- The unit investment cost  $C_{inv}(u)$  is a typical *here-and-now* parameter. Thus, it has a low uncertainty, coinciding with the variability of prices from the different suppliers. A medium level of uncertainty is considered for innovative technologies, such as the Fuel Cell.
- The thermal efficiency of a boiler  $\varepsilon_{th}(BOIL)$  has a low uncertainty as boundaries are set by thermodynamics. The average thermal efficiency of a heat pump  $\varepsilon_{th}(HP)$  depends also on average external temperatures. Average temperature forecasts can be obtained from historical data. Low uncertainty is assumed for these forecasts, to be added to the uncertainty of the thermodynamic models.

Table 3  
Uncertainty characterization applied to the MILP problem.

#	Params	C1	C2	C3	C4	Range	Comment
1	$i$	✓	✓			±5%	Depends on DM choice and conditions. Low uncertainty
2	$\varepsilon_{el}(FC)$	✓		✓		±10%	Thermodynamics sets boundaries. Choice between various options
3	$C_{inv}(BOIL)^a$		✓			±5%	Here-and-now parameter
4	$C_{inv}(FC)$		✓			±10%	Here-and-now parameter. Choice between various options
5	$C_{inv}(STO)$		✓			±5%	Here-and-now parameter
6	$C_{inv}(PV)$		✓			±5%	Here-and-now parameter
7	$C_{inv}(HP)$		✓			±5%	Here-and-now parameter
8	$\varepsilon_{th}(BOIL)$			✓		±5%	Thermodynamics sets boundaries. Very low uncertainty
9	$\varepsilon_{th}(HP)$			✓	✓	±10%	Thermodynamics sets boundaries. Historical data on temperatures
10	$\dot{Q}_{demand,mult}$			✓	✓	±10%	Models and forecasts available. Accuracy of forecasts (Winebrake and Sakva, 2006)
11	$\dot{E}_{demand,mult}$			✓	✓	±10%	Models and forecasts available. Accuracy of forecasts (Winebrake and Sakva, 2006)
12	$c_{p,mult}(PV)$				✓	±10%	Depends on solar irradiation. Accuracy of forecasts
13	$c_{p,mult}(HP)$				✓	±5%	Historical data on temperatures
14	$n$				✓	±10%	For old tech. data in (Ecoinvent Centre). For new tech. (e.g. FC) higher uncertainty
15	$c_{el,buy,mult}$				✓	±50%	Forecast unreliable. Errors in forecasts (Siddiqui and Marnay, 2006)
16	$c_{ng,mult}$				✓	±50%	Forecast unreliable. Errors in forecasts (Siddiqui and Marnay, 2006)

<sup>a</sup>  $C_{inv}(u)$  groups  $C_{inv,1}(u)$  and  $C_{inv,2}(u)$ .

- Heating and electricity demand can be assessed by models or forecast based on historical data. Here the latter case is considered, and references on the forecast accuracy are used to define the ranges of variation.
- $c_p(PV, t)$  is modelled to be dependent only on average monthly solar irradiation. Solar irradiation forecasts can be obtained from historical data. Medium uncertainty is assumed for these forecasts.  $c_p(HP, t)$  uncertainty is related to the possibility of extreme external temperature values. As above, low uncertainty is assumed for temperature forecasts.
- The lifetime  $n$  of the technologies is referenced from historical data. Medium uncertainty is considered due to the impact of fuel cells, which are at an early stage of development.
- Cost parameters  $c_{el,buy}(t)$  and  $c_{ng}(t)$  are often forecast based on historical data. Based on the forecast inaccuracy discussed in Section 1.1, a very high uncertainty is considered for these parameters.

These ranges of variation are the input to the GSA.

#### 4.3. Global Sensitivity Analysis

The third step is the Global Sensitivity Analysis. The theoretical background is thoroughly presented in Saltelli *et al.* (2008) and Sin *et al.* (2009).

In general terms, given a model in the form  $Y = f(X_1, X_2, \dots, X_k)$ , the output  $Y$  depends on a set of  $k$  uncertain parameters  $X_i$ .  $S_{T_i}$ , the total sensitivity effect of the  $i$ -th input, is defined as the ratio between the expected value of the output variance  $V(Y)$  when only  $X_i$  is varying (all other parameters are fixed), and  $V(Y)$ :

$$S_{T_i} = \frac{E(V(Y|X_{\sim i}))}{V(Y)}. \quad (16)$$

At the numerator the expected value is calculated so that  $S_{T_i}$  does not depend on the chosen values for the fixed parameters, but instead interaction of  $X_i$  with the other parameters is taken into account.

Theoretical results show that  $S_{T_i} = 0$  is a necessary and sufficient condition to declare  $X_i$  as a non-influential parameter. Since  $S_{T_i}$  is often expensive to calculate even for relatively low  $k$  values, the Elementary Effects method (Morris screening) is chosen (Morris, 1991). The method is a One-at-a-Time Global Sensitivity Analysis which allows estimating a proxy of  $S_{T_i}$  in a computationally efficient way. It is a discrete sampling method:  $r$  trajectories are defined, each one of them consisting of  $(k + 1)$  steps. At each step of a trajectory the model is executed with one parameter varied of the quantity  $\pm\Delta$  across  $p$  levels. This way, for each trajectory all parameters are varied once, allowing the calculation of the elementary effect for each parameter. The Elementary Effect (EE) of the  $i$ -th parameter is defined as follows:

$$EE_i = \frac{[Y(X_1, X_2, \dots, X_{i-1}, X_i + \Delta, \dots, X_k) - Y(X_1, X_2, \dots, X_k)]}{\Delta}. \quad (17)$$

Once the Elementary Effects are calculated for each parameter and for each trajectory,  $\mu_i^*$  is calculated by averaging the Elementary Effect of the  $i$ -th parameter over the  $r$  trajectories. In order to compare the effect of each input variation on different model outputs,  $\mu_i^*$  is normalized as proposed in (Sin *et al.*, 2009).  $\mu_i^*$  is a proxy for  $S_{T_i}$ :

$$\mu_i^* = \frac{1}{r} \sum_{j=1}^r |EE_i^j|. \quad (18)$$

##### 4.3.1. Application to the Example MILP Problem

With reference to the methodology defined in Morris (1991), the method is run for  $k = 16$  parameters. Due to the high number of parameters, a value of  $r = 100$  trajectories is selected, along with  $p = 8$  levels and  $\Delta = p/[2(p - 1)]$ . Firstly, samples of parameters are generated. Then the Elementary Effects method is applied by changing the parameter values for each run, allowing the calculation of  $\mu_i^*$  as in Eq. (18).

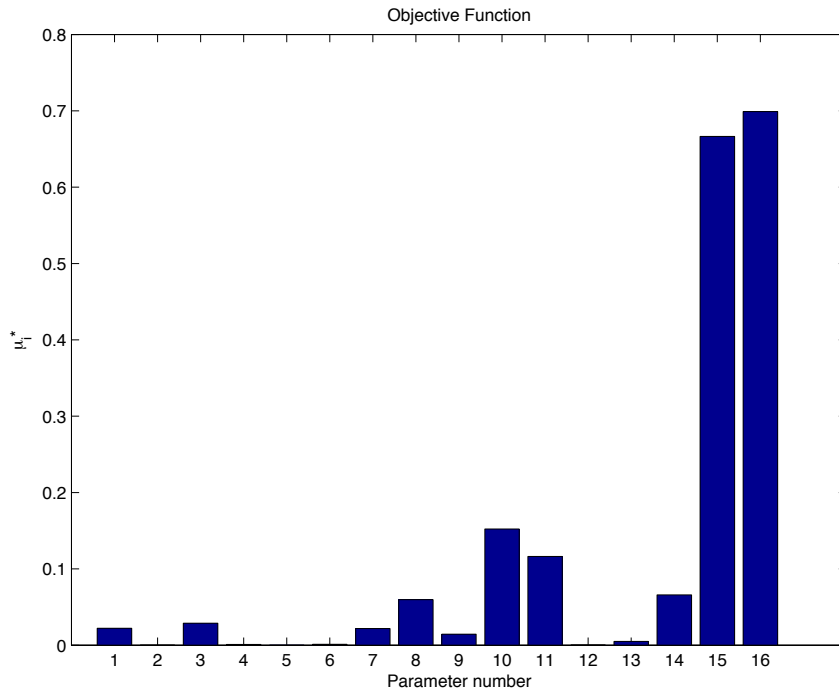

Fig. 4. Elementary effects method: objective function sensitivity to each parameter (parameters numbering as in Table 3).

The outputs of interest of the sensitivity analysis ( $Y$ ) are the value of the objective function and the installed capacity for each technology,  $f_{size}(u)$ . Figure 4 shows the calculation of  $\mu_i^*$  for the objective function, while Table 8 (Appendix B) reports the results for all the other outputs of interest. Non-influential parameters, with  $\mu_i^*$  close to zero, can be fixed at their nominal value without having an impact on the output. The two cost parameters,  $c_{el, buy, mult}$  and  $c_{ng, mult}$ , are the two most influential parameters on the objective function, the size of BOIL and HP. No parameter has a high influence on the size of the other units. For parameters with intermediate values of  $\mu_i^*$ , such as  $\dot{Q}_{demand, mult}$  and  $\dot{E}_{demand, mult}$  with respect to the objective function, the decision of fixing them or not depends on the modeller's goal for the analysis (Saltelli *et al.*, 2008). Since the goal of the factor fixing analysis is defining priorities for treating the uncertain parameters in the optimization,  $c_{el, buy, mult}$  and  $c_{ng, mult}$  are the two parameters selected for the application of robust optimization being the ones with the highest influence on the outputs of interest.

## 5. Robust Optimization

Robust optimization is applied to the MILP model for the most influential uncertain parameters identified in the previous section. The following subsections describe the methodology and its application to the example optimization problem, and highlight key results with specific focus on energy planning applications.

### 5.1. Methodology

Robust optimization in linear programming was first developed by Soyster (1973). In his formulation, ranges of variation need to be defined for the uncertain parameters, and the optimization problem is solved assuming that all parameters are at worst case. This produces indeed a robust solution, but this solution is highly suboptimal compared to the deterministic case.

This problem has been more recently addressed by Bertsimas and Sim, who have developed a probabilistic approach for robust MILP problems, with the idea that “nature will be restricted in its behaviour, in that only a subset of the coefficients will change in order to adversely affect the solution” (Bertsimas and Sim, 2004). An optimization problem with an uncertain cost parameter vector  $\mathbf{c}$  in the objective function is formulated as follows:

$$\begin{aligned} & \min \mathbf{c}^T \mathbf{x}, \\ & \text{s.t. } \mathbf{Ax} \leq \mathbf{b}, \\ & c_j = [c_j, c_j + d_j] \quad j \in J. \end{aligned} \quad (19)$$

$J$  is the uncertainty set, containing  $\lfloor J \rfloor$  uncertain parameters  $c_j$ , whose range of variation is delimited by the value  $d_j$ . An equivalent formulation applies if the uncertain parameters are in the constraints.

In this formulation of the robust problem, a protection parameter  $\Gamma_0 \in [0, \lfloor J \rfloor]$  is defined. This protection parameter controls the number of parameters at worst case. If  $\Gamma_0 = 0$ , then no parameter is at worst case, i.e. the deterministic solution with all parameters at their nominal values  $c_j$  is obtained. If  $\Gamma_0 = \lfloor J \rfloor$ , then all parameters are at worst case, i.e. Soyster’s solution is obtained. The interest is evaluating how the solution of the optimization problem changes with the variation of  $\Gamma_0$  between these two extreme cases. This allows for the generation of various robust configurations of the energy system, which could then be simulated in the uncertain domain.

### 5.2. Application to the Example MILP Problem

For the MILP problem described in Section 3,  $J = \{c_{el, buy}(t), c_{ng}(t)\}$ . Therefore,  $\lfloor J \rfloor = 26$  is the number of elements in the uncertainty set. Based on the methodology in Bertsimas and Sim (2004), some modifications are made to the optimization model.

The objective function is modified with respect to Eq. (15), with the addition of the protection parameter  $\Gamma_0$  and of the additional variables defined in the robust counterpart:  $z_0, p_{0, el}(t), p_{0, ng}(t)$ . The role of these positive variables is to increase the value of the objective function as more parameters are at worst case.

$$\begin{aligned} & \min \left( \sum_t \left( \sum_u c_{ng}(t) \dot{Q}_{ng}(u, t) + c_{el, buy}(t) \dot{E}_{buy}(t) - c_{el, sell} \dot{E}_{sell}(t) \right) \cdot t_{op}(t) \right. \\ & \quad \left. + \tau \sum_u C_{inv}(u) + z_0 \Gamma_0 + \sum_t p_{0, ng}(t) + \sum_t p_{0, el}(t) \right). \end{aligned} \quad (20)$$

For the cost of purchasing electricity  $c_{el,buy}(t)$  the maximum allowed variation at worst case is fixed by the parameter  $d_{el}$ . The positive variable  $y_{el}(t)$  assumes the value of  $x_j(t) = \dot{E}_{buy}(t) \cdot t_{op}(t)$  at optimality. The following constraints are defined in the robust counterpart to control the number of parameters at worst case:

$$\begin{aligned} z_0 + p_{0,el}(t) &\geq d_{el}y_{el}(t) \quad \forall t, \\ -y_{el}(t) &\leq \dot{E}_{buy}(t) \cdot t_{op}(t) \leq y_{el}(t) \quad \forall t. \end{aligned} \quad (21)$$

The same applies for the cost of natural gas. In this case, as the nominal cost of natural gas is roughly half of the nominal cost of electricity (Table 6), the maximum variation is set as  $d_{ng} = \frac{1}{2}d_{el}$ :

$$z_0 + p_{0,ng}(t) \geq d_{ng}y_{ng}(t) \quad \forall t, \quad (22)$$

$$-y_{ng}(t) \leq \sum_u \dot{Q}_{ng}(u, t) \cdot t_{op}(t) \leq y_{ng}(t) \quad \forall t. \quad (23)$$

### 5.2.1. Results

The robust counterpart of the MILP model is run with values of  $\Gamma_0 \in [0, 26]$  and  $d_{el} \in [0.05, 0.5]$  CHF/kWh, the latter subdivided into 10 discrete intervals. The interest of this analysis is the evaluation of the two outputs of interest, the value of the objective and the installed capacity of each selected technology [kW] at different values of  $\Gamma_0$  and  $d_{el}$ .

Figures 5 and 6 respectively show the obtained results for of  $d_{el} = 0.2$  CHF/kWh and  $d_{el} = 0.45$  CHF/kWh. The two figures display the values of the objective function (total cost) and the size of the different units for increasing values of the protection parameter. For representation purposes, the size of the storage unit is expressed in terms of average monthly power level. In both cases, as expected when  $\Gamma_0 = 0$  the deterministic solution is obtained: the heat for the household is provided by the natural gas Boiler and electricity is imported.

For  $d_{el} = 0.2$  CHF/kWh this solution is the optimum up to values of  $\Gamma_0 \leq 8$ , then the Boiler is replaced by the more efficient Heat Pump for heat production and imports are replaced by the PV panel for electricity production. After this threshold also the objective function value becomes stable.

For the higher range of variation  $d_{el} = 0.45$  CHF/kWh the deterministic solution is replaced for very low values of the protection parameter. For intermediate values of  $\Gamma_0$  the Fuel Cell is also selected. For higher values of the protection parameter the Fuel Cell is no longer selected due to the dependence on the cost of natural gas, and the solution for higher level uncertainty involves the installation of PV panels, Heat Pump and Storage units.

When analysing the choice and size of the different units for the various optimizations performed by varying  $\Gamma_0$  and  $d_{el}$ , the following behaviour is observed:

- **BOIL:** the natural gas Boiler is chosen in the deterministic solution for heat production. With increasing values of  $d_{ng}$ , it is not chosen anymore even at low values of the protection parameter  $\Gamma_0$ .



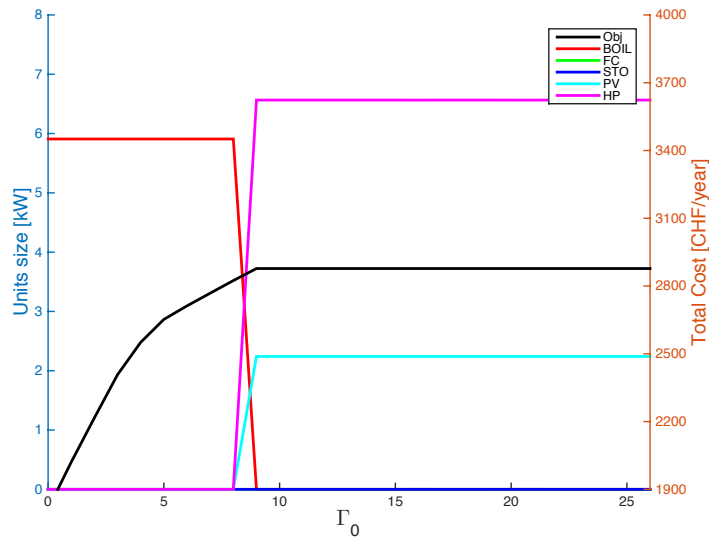

Fig. 5. Robust optimization results: size of the different units and objective value for  $d_{el} = 0.2$  CHF/kWh.

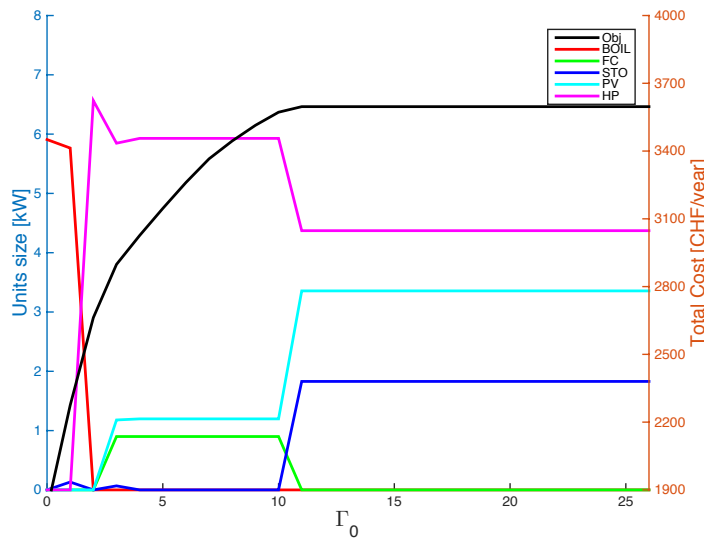

Fig. 6. Robust optimization results: size of the different units and objective value for  $d_{el} = 0.45$  CHF/kWh.

- FC: chosen only for values of  $d_{el} \geq 0.25$  CHF/kWh, the Fuel Cell is selected for intermediate values of the protection parameter, this due to the dependency on natural gas prices.
- STO: interesting for high values of both parameters. Also, low values of  $\Gamma_0$  produce variations in prices which make heat storage an interesting option.
- PV: replaces electricity imports for higher values of  $\Gamma_0$  and  $d_{el}$ .
- HP: replaces natural gas Boiler for higher values of  $\Gamma_0$  and  $d_{el}$ .

Table 4  
 $f_{size}$  value of the configurations chosen for the post sensitivity analysis.

Solution	BOIL	FC	STO	PV	HP
1	0.591	0	0	0	0
2	0.591	0	0	2.000	0
3	0.577	0	1.656	0	0
4	0.499	0	10.692	0	0
5	0.449	0	22.221	0	0
6	0	0	0	0	0.547
7	0	0	0	2.409	0.547
8	0	0	22.866	3.356	0.364
9	0	0	47.788	3.356	0.165
10	0	0.300	0	1.198	0.494
11	0	0.300	0	1.761	0.494
12	0	0.300	2.272	2.033	0.476

The analysis shows how uncertainty of cost parameters can influence strategic energy planning.

This conceptual example shows that, when uncertainty on cost parameters is taken into account, the deterministic solution is replaced by one using more efficient and renewable technologies even for very few parameters at worst case (low values of  $\Gamma_0$ ). This is mainly due to the fact that these technologies have a higher investment-to-operating cost ratio, thus reducing the dependence on the volatility of fuel prices.

## 6. Post-Sensitivity Analysis

By varying the values of the uncertain parameters, various configurations of an energy system are obtained. The idea of the post-sensitivity analysis is to see how these possible solutions would perform when subject to random variation of the uncertain parameters.

To do this, the optimization problem is modified such that the *here-and-now* decision variables, the investment choice for each technology  $y(u)$  and the relative installed capacity  $f_{size}(u)$ , become parameters.  $f(u, t)$ , defining the use of each technology, is left as a variable since operation of the units can be adapted as the future unfolds.

### 6.1. Application to the Example MILP Problem

Table 4 lists the 12 configurations of the energy system in Fig. 1 chosen for the post sensitivity analysis. They are mostly selected among the various outputs of the robust optimization runs. Additionally, other system configurations are evaluated in order to adequately cover the spectrum of possible solutions.

Each of these configurations is simulated 2000 times, with uncertain parameters drawn from uniform distributions defined as follows:  $c_{el, buy} \in [0.09, 0.68]$  CHF/kWh,  $c_{ng} \in [0.0485, 0.347]$  CHF/kWh. The upper limit is consistent with the limits fixed in the robust optimization section. The lower limit is set to half of the nominal price in order to verify how the chosen solutions would perform in the case of favourable uncertainty.

Figure 7 displays the simulation results. For each of the solutions, the value of the objective function over the 2000 simulation runs is displayed by the use of boxplots. In

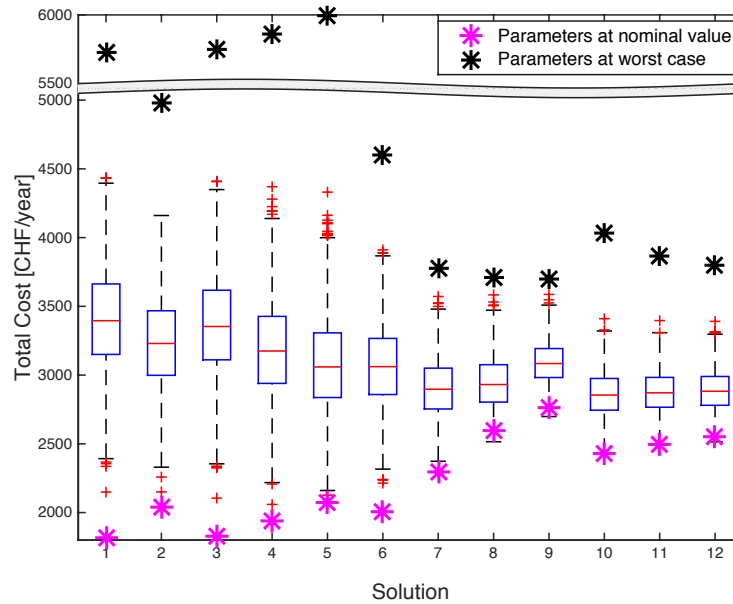

Fig. 7. Boxplot of the post-sensitivity analysis output. The different solutions are numbered according to Table 4.

addition, each solution is evaluated with all the uncertain parameters at their nominal values (purple mark), and at their worst case (black mark). The following observations can be made:

- Solution 1 is the deterministic solution, optimal when all the parameters are at their nominal value. As the natural gas Boiler is supplying the heat and electricity is imported, it is the solution with the highest range of variability.
- Solution 2 substitutes the imports with PV panels for electricity supply. This consistently reduces the effects of the uncertainty of electricity cost.
- In solutions 3, 4 and 5, the natural gas Boiler is coupled with a storage system of gradually increasing size. This has the effect of gradually reducing the Boiler size and the interquartile range, and of improving the median value of the objective function. The storage unit acts as a damper for the price fluctuations.
- In solution 6 the Boiler is replaced by a Heat Pump. The much higher efficiency of the latter allows for a remarkable reduction of the range of variation.
- The output variations due to uncertainty are further reduced in solution 7, in which PV panels are added to partly replace import for electricity supply.
- Solution 8 uses PV panels bigger than in Solution 7, and introduces a storage unit. This further allows for a reduction of the uncertainty oscillations.
- Solution 9 is the solution obtained from the robust optimization with  $\Gamma_0 = 26$  and  $d_{el} = 0.5$  CHF/kWh. As expected from the definition of robust optimization, this solution shows the lowest value when all the parameters are at worst case. It also has the lowest range, which implies the highest cost when all uncertain parameters are at nominal values.

- In solutions 10 and 11 a combination of Fuel Cell, PV and Heat Pump is selected. The combination of these three efficient technologies allows for the best median values, but the dependency on natural gas prices increases the value of the objective function when all parameters are at worst case.
- Solution 12 adds a Storage unit to the previous two solutions, allowing a reduction of the range.

The post-sensitivity analysis further highlights how the robust approach can lead to solutions protecting against worst case scenarios, and allowing for a reduction of the objective variations due to uncertainty. Efficiency and storage act, in this framework, work as uncertainty dampers. The interest of the probabilistic approach to robust optimization adopted in this work is that it allows the comparison of varying solutions for different values of the protection parameter. An example of this is found in the comparison of solution 9 and 10, respectively obtained with values of  $\Gamma_0 = 26$  and  $\Gamma_0 = 9$  ( $d_{el} = 0.5$  CHF/kWh). Solution 9, assuming all parameters at worst case (as in Soyster's formulation) is overconservative. Solution 10, at a risk of an extreme worst case unlikely to happen, shows instead better overall performances over the simulations.

## 7. Conclusions

Long-term energy planning models are often formulated as Mixed-Integer Linear Programming (MILP) problems. In this work, uncertainty characterization and robust optimization are presented and applied to an example conceptual MILP model, showing typical trade-offs in energy planning.

A set of criteria is applied to characterize the uncertain parameters of the MILP model. Uncertainty characterization defines boundaries of variation for the parameters, with the idea that uncertainty is heterogeneous between different model parameters. This is a first step towards the development of a methodology for uncertainty characterization. Uncertainty characterization serves as an input to a Global Sensitivity Analysis, allowing the definition of priorities between the parameters. In the example application, the cost parameters show the highest impact on the outputs of interest.

Robust optimization, following the approach in Bertsimas and Sim (2004), is presented and applied to the example MILP model checking how the optimal solution changes for different values of the protection parameter. Results show how the deterministic solution tends to be replaced by more efficient and cleaner technologies, even for a low number of parameters at worst case. For energy system strategic planning, this highlights the relevant conclusion that, in the uncertain domain, investing in more efficient and renewable technologies can be economically optimal. The linearity of this approach and the avoided need of defining PDFs for the uncertain parameters make it a promising tool for early-stage energy planning. This can have the impact of increasing the current low penetration of uncertainty analysis techniques in the energy field.

The post-sensitivity analysis stage compares the performance of various possible solutions of the MILP problem when simulated in the uncertain domain. This analysis highlights the interest of the adopted probabilistic formulation of robust optimization by com-

paring the performance of solutions obtained with different values of the protection parameter  $\Gamma_0$ . It also shows how renewable and efficient technologies can be dampers of uncertainty, as they reduce the exposure to future price fluctuations.

Future work will involve application of this methodology to realistic and more detailed energy system models at the urban and national level. The criteria used for the uncertainty characterization step could evolve into a methodology allowing a characterization of uncertainty by type and degree, defining a link between uncertainty and the available methods to embed it within optimization problems. Also, a general classification of uncertainty in the context of energy planning is envisioned.

As a next step, the authors see an interest in multi-stage energy planning problems, which could take into account that uncertainty can gradually unfold over time. This can be a relevant asset for decision-making. Within this context, particular attention will be given to the relationship between the concepts of robustness and flexibility, with the perspective that energy system design should not only protect against worst case, but possibly also take advantage of favourable values of the uncertain parameters.

## Appendix A. Parameters Definition

Default values for the parameters in the model.

Table 5  
Unit parameters.

Unit	$\dot{E}_{out,ref}$	$\dot{Q}_{out,ref}$	$\varepsilon_{el}$	$\varepsilon_{th}$	$C_{inv,1}$	$C_{inv,2}^a$	$f_{min}$	$f_{max}$
BOIL	0	10	–	0.9	4000	206	0	3.5
FC	3	0	0.55	0.35	0	20000	0.3	3
STO	0	0.08	–	–	0	150 <sup>b</sup>	0	360
PV	1	0	–	–	0	3500	1	6
HP	0	12	–	4	10000	5000	0	2

<sup>a</sup>Investment cost data from producer catalogs in Switzerland.

<sup>b</sup>Investment cost for large scale storage is assumed.

Table 6  
Multiperiod parameters.

Period	$c_{el,buy}^a$	$c_{ng}^b$	$c_{el,sell}$	$\dot{Q}_{demand}$	$\dot{E}_{demand}$	$t_{op}$
1	0.22	0.097	0.088	2.513	0.371	744
2	0.20	0.097	0.080	2.624	0.349	672
3	0.17	0.097	0.068	1.227	0.377	744
4	0.18	0.097	0.072	0.687	0.335	720
5	0.16	0.097	0.064	0.192	0.318	744
6	0.15	0.097	0.060	0	0.273	720
7	0.15	0.097	0.060	0	0.354	744
8	0.16	0.097	0.064	0	0.331	744
9	0.17	0.097	0.068	0.026	0.297	720
10	0.18	0.097	0.072	0.595	0.352	744
11	0.20	0.097	0.080	1.790	0.416	720
12	0.22	0.097	0.088	2.310	0.375	744
13	0.18	0.097	0.072	5.908	3.764	0.01

<sup>a</sup>Yearly price variation is assumed.

<sup>b</sup>Average values for Natural gas and electricity prices taken from <http://www.gaz-naturel.ch>.

Table 7  
 $c_p$  parameter definition.

	BOIL	FC	STO	PV <sup>a</sup>	HP
1	0.9	0.9	1	0.054	0.9
2	0.9	0.9	1	0.087	0.9
3	0.9	0.9	1	0.122	0.9
4	0.9	0.9	1	0.151	0.9
5	0.9	0.9	1	0.159	0.9
6	0.9	0.9	1	0.155	0.9
7	0.9	0.9	1	0.167	0.9
8	0.9	0.9	1	0.159	0.9
9	0.9	0.9	1	0.126	0.9
10	0.9	0.9	1	0.089	0.9
11	0.9	0.9	1	0.052	0.9
12	0.9	0.9	1	0.037	0.9
13	1	1	1	1	0.9

<sup>a</sup>Monthly variation of PV in Switzerland in 2011 <http://www.swiss-energyscope.ch>.

## Appendix B. Uncertainty Analysis

Detailed results of the GSA applied with the Elementary Effects method.

Table 8  
 $\mu_i^*$  for each parameter with respect to the size of each unit,  $f_{size}(u)$ .

#	Params	BOIL	FC	STO	PV	HP
1	$i$	0.00	0.00	0.05	0.11	0.00
2	$\varepsilon_{el}(FC)$	0.00	0.00	0.00	0.00	0.00
3	$C_{inv}(BOIL)$	0.01	0.00	0.00	0.00	0.01
4	$C_{inv}(FC)$	0.00	0.00	0.00	0.00	0.00
5	$C_{inv}(STO)$	0.00	0.00	0.00	0.00	0.00
6	$C_{inv}(PV)$	0.00	0.06	0.04	0.07	0.00
7	$C_{inv}(HP)$	0.13	0.00	0.04	0.00	0.13
8	$\varepsilon_{th}(BOIL)$	0.05	0.00	0.18	0.00	0.05
9	$\varepsilon_{th}(HP)$	0.08	0.00	0.00	0.00	0.07
10	$Q_{demand,mult}$	0.18	0.00	0.12	0.00	0.12
11	$E_{demand,mult}$	0.00	0.06	0.00	0.03	0.00
12	$c_{p,mult}(PV)$	0.00	0.00	0.00	0.04	0.00
13	$c_{p,mult}(HP)$	0.03	0.00	0.13	0.00	0.04
14	$n$	0.03	0.06	0.02	0.24	0.03
15	$c_{el,buy,mult}$	0.36	0.06	0.14	0.14	0.35
16	$c_{ng,mult}$	0.71	0.11	0.01	0.06	0.71

## References

- Bertsimas, D., Sim, M. (2004). The price of robustness. *Operations Research*, 52(1), 35–53.  
 COGEN Europe (2014). *IPCC confirms role of CHP in long-term CO<sub>2</sub> reduction*.

- de Neufville, R. (2013). *Flexibility in systems planning and design*. EPFL Lausanne, 2013. Presentation.
- Dorer, V., Weber, R., Weber, A. (November 2005). Performance assessment of fuel cell micro-cogeneration systems for residential buildings. *Energy and Buildings*, 37(11), 1132–1146.
- Dubuis, M. (2012). *Energy system design under uncertainty*. Doctoral thesis, EPFL Lausanne.
- Ecoinvent Centre. *Ecoinvent report No. 06 – heat pumps*. Technical report.
- Energy Information Administration, Office of Integrated Analysis and Forecasting NEMS (2003). *The national energy modeling system: an overview 2003*. Technical report, U.S. Department of Energy, Washington.
- Fishbone, L.G., Abilock, H. (1981). Markal, a linear-programming model for energy systems analysis: technical description of the bnl version. *International Journal of Energy Research*, 5(4), 353–375.
- Fourer, R., Gay, D., Kernighan, B. (2002). *AMPL: A Modeling Language for Mathematical Programming*. Duxbury Press.
- Grossmann, I.E., Apap, R.M., Calfa, B.A., Garcia-Herreros, P., Zhang, Q. (2015). Recent advances in mathematical programming techniques for the optimization of process systems under uncertainty. In: Huusom, J.K., Gani, R., Gernaey, K.V. (Eds.) *Computer Aided Chemical Engineering, 12th International Symposium on Process Systems Engineering and 25th European Symposium on Computer Aided Process Engineering*, Vol. 37. Elsevier, pp. 1–14.
- Hajimiragha, A.H., Canizares, C.A., Fowler, M.W., Moazeni, S., Elkamel, A. (2011). A robust optimization approach for planning the transition to plug-in hybrid electric vehicles. *IEEE Transactions on Power Systems*, 26(4), 2264–2274.
- Hodges, J.S., Dewar, J.A. (1992). *Is it you or your model talking? A framework for model validation*. Technical report, RAND Corporation.
- IEA – International Energy Agency (2014). *Energy technology perspectives 2014*. Technical report.
- Koltsaklis, N.E., Dagoumas, A.S., Kopanos, G.M., Pistikopoulos, E.N., Georgiadis, M.C. (2014). A spatial multi-period long-term energy planning model: a case study of the Greek power system. *Applied Energy*, 115, 456–482.
- Koomey, J., Craig, P., Gadgil, A., Lorenzetti, D. (2003). Improving long-range energy modeling: A plea for historical retrospectives. *The Energy Journal*, 24(4), 75–91.
- Krugman, P. (2013). Gambling with civilization. *The New York Review of Books*.
- Lamont, A.D. (2008). Assessing the long-term system value of intermittent electric generation technologies. *Energy Economics*, 30(3), 1208–1231.
- Løken, E., Botterud, A., Holen, A.T. (2006). Decision analysis and uncertainties in planning local energy systems. In: *International Conference on Probabilistic Methods Applied to Power Systems, 2006. PMAPS 2006*, pp. 1–8.
- Morgan, M.G. (2009). *CCSP, 2009: best practice approaches for characterizing, communicating and incorporating scientific uncertainty in climate decision making*. Technical Report SAP 5.2, National Oceanic and Atmospheric Administration, Washington.
- Morris, M.D. (1991). Factorial sampling plans for preliminary computational experiments. *Technometrics*, 33(2), 161–174.
- Nordhaus, W.D. (1973). The allocation of energy resources. *Brookings Papers on Economic Activity*, 4(3), 529–576.
- Pernet, M. (2014). *Smart heat design – urban energy system design under uncertainty*. Master thesis, EPFL Lausanne, 2014.
- Saltelli, A., Ratto, M., Andres, T., Campolongo, F., Cariboni, J., Gatelli, D., Saisana, M., Tarantola, S. (2008). *Global Sensitivity Analysis: The Primer*. John Wiley & Sons.
- Siddiqui, A.S., Marnay, C. (2006). *Addressing an uncertain future using scenario analysis*. Technical Report LBNL-62313, Ernest Orlando Berkeley National Laboratory.
- Sin, G., Gernaey, K.V., Lantz, A.E. (2009). Good modeling practice for PAT applications: propagation of input uncertainty and sensitivity analysis. *Biotechnology Progress*, 25(4), 1043–1053.
- Soroudi, A., Amraee, T. (2013). Decision making under uncertainty in energy systems: state of the art. *Renewable and Sustainable Energy Reviews*, 28, 376–384.
- Soyster, A.L. (1973). Convex programming with set-inclusive constraints and applications to inexact linear programming. *Operations Research*, 21(5), 1154–1157.
- Winebrake, J.J., Sakva, D. (2006). An evaluation of errors in US energy forecasts: 1982–2003. *Energy Policy*, 34(18), 3475–3483.
- Zhou, P., Ang, B.W., Poh, K.L. (2006). Decision analysis in energy and environmental modeling: an update. *Energy*, 31(14), 2604–2622.

**S. Moret** is a PhD candidate in the Energy doctoral program at École Polytechnique Fédérale de Lausanne (EPFL, Switzerland) where he is a member of the Industrial Process and Energy System Engineering (IPESE) research group led by Professor François Maréchal. He holds a Bachelor's degree in Industrial Engineering and a Master's degree in Mechanical Engineering from the University of Padova (Italy). His main research interest is strategic energy planning under uncertainty.

**M. Bierlaire** holds a PhD in Mathematical Sciences from the Facultés Universitaires Notre-Dame de la Paix, Namur, Belgium (University of Namur). He is currently a full-time professor at EPFL, where he is the head of the Transport and Mobility Laboratory. His main expertise is in the design, development and applications of models and algorithms for the design, analysis and management of transportation systems. Namely, he has been active in demand modelling (discrete choice models, estimation of origin-destination matrices), operations research (scheduling, assignment, etc.) and Dynamic Traffic Management Systems.

**F. Maréchal** holds a PhD in Engineering from the University of Liège. He is currently an adjunct professor at EPFL, where he is the head of the Industrial Process and Energy System Engineering (IPESE) research group. His major research topics are process integration techniques, energy analysis, process modelling and thermo-economic optimization. Main applications are rational use of water and energy in industrial processes and industrial production sites, energy conversion and process design, integrated energy systems in urban areas.

## **Robastinis optimizavimas strategiškai planuoti energiją**

Stefano MORET, Michel BIERLAIRE, François MARÉCHAL

Ilgalaikis energetinių sistemų planavimas dažnai remiasi deterministiniu ekonominiu optimizavimu ir siekia prognozuoti kuro kainas. Jei kuro kainos yra perversinamos, neatsižvelgiama į atsinaujinančias ir kitas efektyvesnio alternatyvaus kuro technologijas. Šiame darbe šios problemos nagrinėjamos atsižvelgiant į energetinio planavimo neapibrėžtis, kurių apžvalga darbe taip pat pateikiama. Robastinis optimizavimo metodas naudojamas mišraus sveikaskaičio tiesinio programavimo problemai, realizuojančiai tipinį energijos planavimo uždavinį. Yra parodyta, kad sprendimas daugiau investuoti į efektyvias ir ekologiškas technologijas gali būti optimalus.