

## RURAL ELECTRIFICATION IN ETHIOPIA WITH THE SHIELD WIRE SCHEME

F. ILICETO<sup>†</sup>, F. M. GATTA, S. LAURIA

University of Rome "La Sapienza"

Rome, Italy

<sup>†</sup> E-mail address: francesco.iliceto@uniroma1.it

M. DEBEBE, M. HUSSEN

Ethiopian Electric Power Corporation

Addis Ababa, Ethiopia

### SUMMARY

Firstly, the paper briefly describes the technique for 3-phase and single-phase power distribution along HV (115-330kV) transmission lines via the insulated shield wires, energized at MV (20-34.5kV) from the main HV/MV transformer stations, using the ground as a MV phase conductor.

A computer program based on phase coordinates is presented, expressly developed for the analysis of this unconventional low cost grid based rural electrification technique, referred to as the "Shield Wire Scheme" (SWS).

The paper then describes the SWSs in operation or under construction in Ethiopia. The design criteria and the commissioning results are reported for three "Single-Phase Earth-Return" SWSs, which have been put into operation in 2003. The planning and engineering criteria applied for four "3-Phase" SWSs under construction at the time of writing are then described. These SWSs will provide electricity to 50 villages and small town, to irrigation pumping stations, to two large state owned farms, and to tea, coffee and fruit processing plants employing 7000 workers.

Brief information is given on SWSs in operation, under construction and planned in other developing countries.

### 1. BRIEF DESCRIPTION OF THE INSULATED SHIELD WIRE DISTRIBUTION SCHEMES

In many cases, new HV lines built for the supply of power to major towns in developing countries, or for connecting remote power plants to the system, are routed not far from highways along which there are several minor towns, villages and farms without electricity supply. The distance of these communities from the closest HV/MV transformer station may exceed 100 km. Owing to the small amount of power to be supplied at long distances, conventional 3-phase MV lines and/or addition of HV/MV stations are not feasible from an economic point of view.

A very low cost solution is the Shield Wire Scheme (SWS) first conceived by one of the authors [1] and applied commercially firstly in Ghana [2] [3] [5]. The SWS consists of insulating the shield wire(s) (SW(s)) of the HV lines from the towers and energizing the SW(s) at MV (20-34.5 kV) from the HV/MV transformer station at one end of the HV line. MV/LV transformers are connected between the SW(s) and ground for power supply to the loads.

The applicable SWSs, presented in previous papers [2] [3] [4], are shown in Fig. 1: Scheme A – "Single-Phase Earth-Return"; Scheme B – "Single-Phase Metallic Return"; Scheme C – "V"; Scheme D – "3-Phase".

Scheme A is applicable on HV lines provided with one shield wire. Schemes B, C and D are feasible on HV lines provided with two shield wires. Schemes A and B perform single-phase

distribution with earth return and metallic return of current, respectively. Scheme C and D perform 3-phase distribution, the 3<sup>rd</sup> conductor being the earth path.

The "3-Phase" scheme is the most frequently used because it supplies all the loads as a conventional 3-phase distribution system, including large induction motors, without restrictions. The "V" scheme is simpler, but has limited application, because voltage symmetrization is less accurate than in the "3-Phase" Scheme, thus enabling the supply of only a small amount of 3-phase load (say, 10% of total) in addition to single-phase loads. The "Single-Phase Earth-Return" Scheme has been applied on HV lines already built or designed with one SW only.

Laboratory investigations [2], EMTP-ATP computer analysis [7] [9] and 15-years of extensive field experience [5] have proven that the insulation for MV of the SWs of HV lines ( $V \geq 115$  kV) and energization at MV (up to 34.5 kV) does not erode the lightning shielding efficiency of the SWs and has a negligible effect on the back-flashover rate of the HV circuit. When lightning strikes a SW insulated for MV or a tower peak, a flashover occurs across the arcing horns of the SW insulator. Then SW(s) are grounded via the arc and behave for the HV circuit as conventional SWs. The lightning current amplitude liable to cause the back-flashover is reduced by only 1 to 5 % depending on the ratio of lightning impulse insulation levels of line HV conductors and of SWs [7] [9].

The ground return of the current is a very economic concept also in regions with relatively high soil resistivity, because the cost of grounding electrodes is small in developing countries for the current flow of interest. The earth return path has a much lower resistance than usual distribution conductors. It is calculated at  $10^{-4} \pi^2 f$  ( $\Omega/\text{km}$ ), i.e.  $0.05 \Omega/\text{km}$  at 50 Hz, equivalent to a  $570 \text{ mm}^2$  aluminium cable.

In the "3-Phase" Scheme (Fig.1-D), the two insulated SWs and the ground return path form a 3-phase circuit which is supplied at MV from a HV/MV station by a transformer winding with one terminal permanently grounded. Consequently, the wire-to-ground ( $w_1\text{-Gr}$  and  $w_2\text{-Gr}$ ) rms voltages are equal to the wire-to-wire ( $w_1\text{-}w_2$ ) rms voltage. The shield wire line (SWL) is a 3-phase unsymmetrical circuit, with the ground return being used as the 3<sup>rd</sup> phase conductor.

As pointed out above, the resistance of the earth path is much smaller than the resistance of any practical SW cable; the reactance of the earth path is usually slightly smaller [2]. The capacitive leakage currents terminating to the SWs and earth path (3<sup>rd</sup> phase of SWL) are unbalanced owing to diversity of the partial capacitances and of the currents capacitively induced by the HV conductors.

The applied concept is to make symmetrical the "3-Phase" circuit formed by the two SWs and the earth path, with simple compensating components, which introduce complementary

asymmetries tailored to cancel out or drastically reduce the inherent asymmetries of the SWL. The target is to limit the negative sequence component of voltages generally within 1% (in no case to exceed 2%). This is achieved by:

- a series resistor-reactor in the earth path (R-L in Fig.1-D) in order to raise the earth path voltage drop to about the same value as the voltage drop on SWs;
- a p.f. correction capacitor branched between the two wires ( $C_{ww}$  in Fig.1-D), larger than the p.f. correction capacitors branched from each SW and ground ( $C_{w10}$  and  $C_{w20}$ ), so that the total capacitive currents flowing to the SWs and to the earth (leakage currents in the air from wires, earth and HV conductors plus the capacitors currents) have about the same amplitude and are phase shifted by 120° and 240°.

The supply of “Single-Phase Earth-Return” and of “V” SWLs [2] [3] [4] is usually made directly from the MV busbars of a

HV/MV substation, via a circuit breaker (CB).

The supply of “3-Phase” SWLs is feasible: i) from a dedicated MV winding of a HV/MV step-down transformer via a MV 2-pole CB as shown in Fig.1-D [11]; ii) alternatively, via a MV/MV interposing transformer providing galvanic insulation and the suitable voltage for SWL. The supply winding of SWL is in any case operated with one terminal grounded via the compensating R-L circuit. When a MV/MV interposing transformer is used, this is supplied via a standard MV 3-pole CB, for switching and protecting, as one block on primary side, the interposing transformer and the SWL [4], [5], [6].

The “3-Phase” SWS supplies MV/LV conventional distribution transformers operated with one MV terminal permanently grounded (Fig.1-D). This SWS can supply 100% 3-phase load, like a conventional 3-phase distribution feeder.

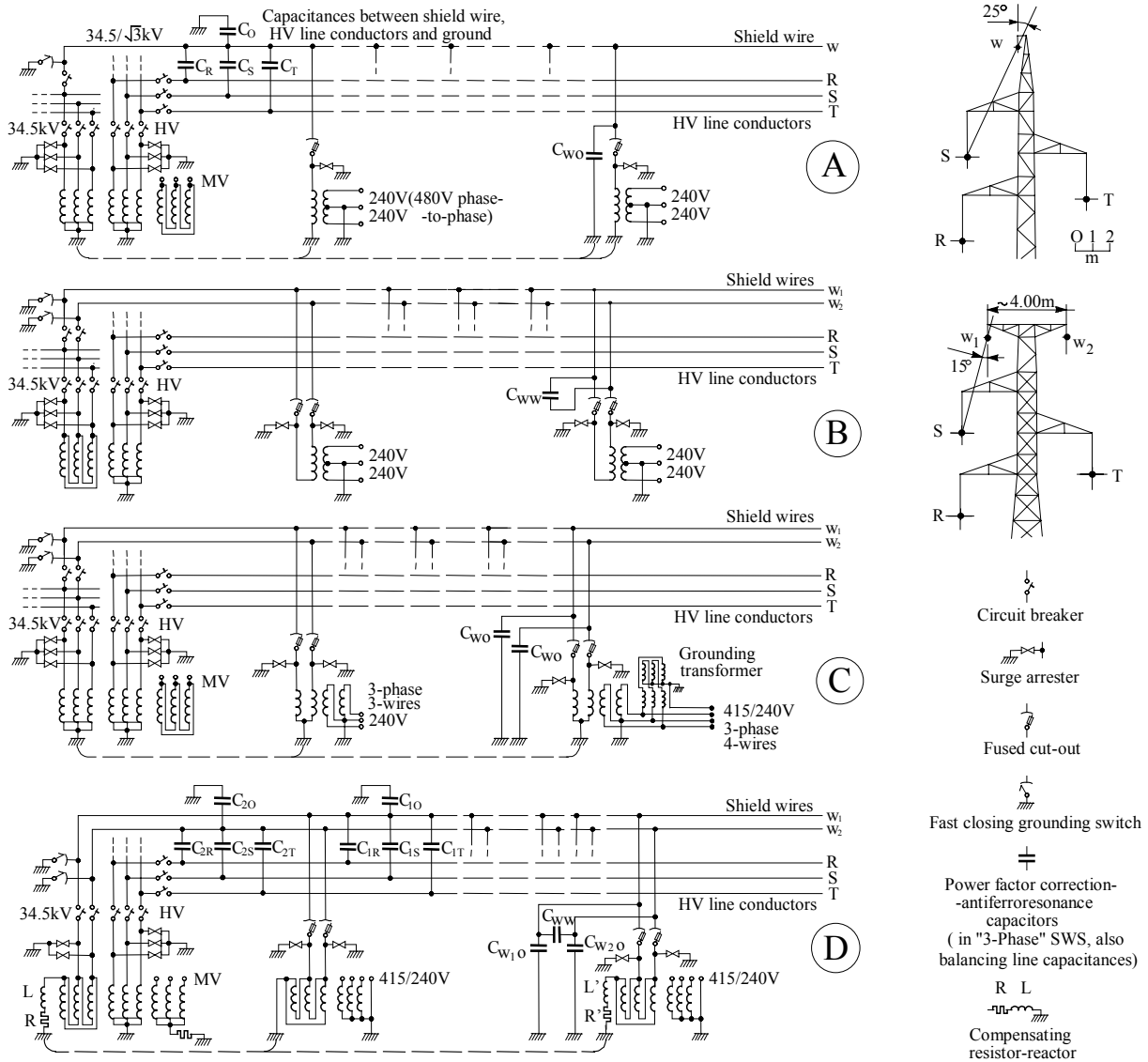

Fig. 1- SWSs applicable to a HV ( $V_n \geq 115$  kV) single-circuit line: A = Single-Phase Earth-Return (typical line tower is shown on top right); B = Single-Phase Metallic-Return; C = “V” SWS; D = “3-Phase” SWS (typical line tower for SWSs B, C and D is shown on middle right).

Where desired, it can also be used for single-phase distribution, via MV/LV transformers branched from one SW and ground and from the two SWs. The "3-Phase" SWS is a balanced load for the HV transmission system, if the consumers' load is balanced as in usual distribution.

Capacitors  $C_{ww}$ ,  $C_{w10}$  and  $C_{w20}$  perform three functions: p.f. correction, prevention of ferroresonance and circuit balancing in "3-Phase" SWS. These functions and the one of the fast closing grounding switch (Fig. 1) are described in ref. [2], [3]. In some cases, the communities or farms to be supplied are located at some distance from the HV line route. Supply is then made via lateral MV lines, equipped with one conductor for the "Single-Phase Earth-Return" SWS or with 2 conductors for the "3-Phase" SWS. The length of lateral lines built so far has been up to 25 km from take-off tower of HV line.

The grounding system for earth-return of current is described in [2] and operation experience is reported in [3] [4] [5] [11]. The largest current flows in the grounding system of the HV/MV substations supplying the SWL(s) (see Fig.1). This does not pose problems because the extensive meshed grounding system of HV stations generally has a resistance not exceeding 1 or 2  $\Omega$ . Field experience has shown that, with a current flow in the grounding system of HV/MV stations of up to 100 A (load of 6 MVA in a 34.5 kV "3-Phase" SWL), the step and touch voltages generally do not exceed 7 V.

The "3-Phase" SWL (Fig.1-D) has practically the same power distribution capability of a conventional MV long feeder of the same rated voltage, with conductors of the same ohmic resistance. A 34.5 kV, 50 Hz-100 km long SWL formed by two ACSR SWs of 76.9 mm<sup>2</sup> ( $S_{Al}=48.57$  mm<sup>2</sup>;  $S_{St}=28.33$  mm<sup>2</sup>;  $r_{40^\circ C}=0.646$   $\Omega$ /km) can supply up to 4 MVA of distributed load, including large induction motors (rated up to 200 kW).

The single-phase SWSs, A and B in Fig. 1, are seen by the HV supply network as single-phase loads. When two or more such SWSs are supplied from the same HV/MV substation, or from substations of the same region, the unbalance is minimized by connecting the SWLs to different couples of MV phases. Where this is impracticable or insufficient, a MV L-C circuit can be branched in parallel with the SWL, designed for compensating the negative sequence currents produced by the single-phase load [3].

The steady-state and transient analyses of SWSs are somewhat complex, owing to the electromagnetic coupling with the HV circuit, to the earth return of current and to the unbalanced nature of the "V" and "3-Phase" SWLs.

## 2. DESCRIPTION OF A PROGRAM FOR SWSs ANALYSIS

The unsymmetrical configuration of SWSs requires, for an accurate analysis of its operation, the simulation of all the electrostatic and electromagnetic couplings between the conductors of the HV circuit, the insulated SWs energized at MV and the earth path used for return of current.

Initially, the steady-state operation analysis of SWSs has been performed with the ATP-EMTP (Alternative Transients

Program–Electromagnetic Transients Program), a powerful and accurate tool, the use of which is however quite complex and time consuming. Moreover, the ATPs load-flow option is not very efficient when dealing with radial systems with low X/R ratios, both these features being typical of distribution systems.

As an alternative to the EMTP, special programs based on the 2-phase symmetrical components transformation were developed in 1989 [10] for the steady-state, temporary overvoltage and short circuit analyses of the "V" and "3-Phase" SWSs. These programs had the merit of simplicity of use, but were based on some simulation approximations of SWS symmetrization.

To overcome these limitations, a new program has been developed [8] that uses the phase coordinates, expressly implemented for the accurate analysis of any type of SWS.

The program firstly builds the nodal admittance matrix, in phase coordinates, of each system component (multiconductor line, transformers, induction motors, constant power and constant impedance loads, etc.).

The total nodal admittance system matrix,  $[Y]$ , is then assembled without any topological constraint, by mapping the individual "component" matrices into the global one. The network is described by the linear system  $[I]=[Y][E]$ , where  $[I]$  and  $[E]$  are the nodal currents and voltages, respectively. By partitioning the  $[Y]$  matrix into "known" and "unknown" voltage nodes (suffixed "k" and "u", respectively) the following system of equations is obtained:

$$\begin{bmatrix} I_k \\ I_u \end{bmatrix} = \begin{bmatrix} Y_{kk} & Y_{ku} \\ Y_{uk} & Y_{uu} \end{bmatrix} \begin{bmatrix} E_k \\ E_u \end{bmatrix} \quad (1)$$

System (1) yields the following expressions of the unknown voltages  $[E_u]$ :

$$[E_u] = [Y_{uu}]^{-1} \{ [I_u] - [Y_{uk}] [E_k] \} \quad (2)$$

Since the actual operation generally requires simulation of loads in steady-state conditions as constant active and reactive power, their equivalent current injection depends on the nodal voltage. The solution therefore requires an iterative method. An initial estimate of the nodal voltages is required in order to calculate the injected currents, based on equations:

$$I_i = - \left( \frac{N_i}{E_i} \right)^* \quad (3)$$

where  $N_i$  is the complex power at node 'i'. System (2) is then solved iteratively: the  $[I_u]$  vector estimated by equation (3) is substituted in (2) to obtain the unknown voltages  $[E_u]$ . By multiplying those voltages by the estimated currents, the powers absorbed by the (P,Q) loads are calculated. If the convergence condition is not fulfilled for all the constant-power nodes, i.e. the calculated power is not within the prescribed tolerance, the voltage vector is used to perform another iteration. The voltage initialization is simply performed by solving system (2) without injected currents, i.e. by neglecting the (P,Q) loads: this yields an initial voltage estimate which is an excellent starting point for the iterative process.

The described algorithm proved to be very efficient and robust. In fact, convergence is obtained with a few iterations, even in presence of large unbalanced conditions and unsymmetrical faults. The algorithm is specifically suited to the analysis of single-point supplied networks like SWSs and radial distribution systems, although it is not restricted to radial networks.

The analysis of three-phase induction motor loads and small three-phase generators operated at constant p.f. requires a hybrid approach combining the above described phase value modelling with sequence-value representation of the rotating devices. It should be pointed out that the Y-bus solution method is unaffected, neither by these changes nor by the limitation of the single point of supply.

The new program has the capacity to calculate the unsymmetrical shunt capacitors to be connected to the "3-Phase" SWS which, besides providing p.f. correction and preventing ferroresonance [2] [3], make the total capacitive currents flowing to the two SWs and to the earth almost equal in amplitude and phase shifted by 120° and 240°, thereby optimising the shunt symmetrization.

The program has been up-rated very recently at Rome University "La Sapienza" by including an algorithm for the automatic identification of the optimal values of the symmetrization capacitors and of the R-L circuit used for grounding one terminal of the transformer at sending end and, where applicable, at another location along the "3-Phase" SWL (R-L and R'-L' circuits in Fig. 1-D). The program minimizes the average value of the residual negative-sequence voltages at the LV terminals of MV/LV transformers along the SWL, the average being weighted on the basis of the load active powers.

### 3. RURAL ELECTRIFICATION IN ETHIOPIA USING THE SWSs

#### 3.1 General information

At the time of writing, only 13% of the 70 millions of Ethiopian people are served with electricity. The Government of Ethiopia and EEPKO, the Ethiopian Electric Power Corporation, are therefore engaged in an effort to expand rural electrification.

Among the means aimed at reducing the investment cost which, as well known, is a major obstacle to rural electrification in regions with low load density and low economic income, the World Bank has recommended to apply, where appropriate, the SWS including the "Single-Phase Earth-Return" scheme.

As regards conventional distribution, EEPKO has recently started MV distribution at 33 kV, because the 15 kV rated voltage in use in the past is recognized to be not economical in the rural, low load density areas where radial long reach MV lines are appropriate.

EEPKO has applied the SWSs for power supply to the villages, to some small towns, to a few large farms and to tea-coffee-fruit processing plants located along some 132 kV and 230 kV transmission lines or at a distance up to 27 kilometres from the HV line route.

The regions crossed by the 132kV and 230kV lines equipped with the SWSs are mostly mountainous, partly covered by tropical forest, with few access roads. Nature is intact and beautiful, but it is in many locations very difficult for construction and maintenance of transmission and distribution lines.

Construction of HV lines in the mountainous regions is less penalized than construction of MV lines. In fact, the tower spotting of HV lines supported by lattice galvanized steel towers can take advantage of the profile by crossing valleys with long spans. MV lines have the span length limited: on the one hand, by the loading capability of locally fabricated concrete poles; on the other hand, by the small separation between phase conductors. Transport and erection of concrete poles on the sides or tops of mountains is difficult. Contractors therefore prefer to build MV lines which closely follow the winding roads and end up being much longer than the point-to-point distance and expensive. Local wood poles in Ethiopia do not have mechanical strength adequate for MV lines with span length providing an economic design. The SWS overcomes these problems, because it provides a MV circuit along the HV circuit at very little cost. Other reasons justifying the use of the "3-Phase" SWSs are the following:

- The "3-Phase" SWLs operated at 34.5 kV (max. voltage in use for distribution) have a loading capability of some MW and reach can exceed 100 km [3] [4] [5] [11].
- Earth-return of current has been used many decades for single-phase rural electrification and 15 years in commercial SWSs. This technique does not pose problems even if the soil resistivity is relatively high. The earth is an ideal conductor in rural areas of developing countries because: (i) cost is very small (cost items are grounding rods and grounding conductors, installed for performing also other functions); (ii) power losses are very small; (iii) unlike a conventional line conductor, it is neither exposed to insulation failures nor to interruptions; (iv) maintenance has negligible cost.
- Although the analysis of SWSs is somewhat complex, operation is simple because only conventional distribution equipment is used, with ordinary operational methods and without electronic power devices.
- Although the phase-to-Ground operation voltage in the "3-Phase" SWS is higher by a factor of  $\sqrt{3} = 1.732$  in comparison with the conventional lines, the required increase of insulation is only 15-20 % above the standard for conventional MV lines and equipment (BIL of 200 kV instead of 170 kV for the 34.5 rated voltage) [3] [4] [5] [11].
- SWLs are part of the HV line. They are therefore inherently much more reliable than conventional MV lines and do not require specific maintenance, except for visual inspection of SW insulators during HV line patrolling. MV lines require frequent clearing of right-of-way (ROW) in tropical forests.
- Cost of making electricity available at MV with the SWSs to communities located along the HV lines is only 10-15% of cost of independent MV lines on the same ROW.
- If an optical ground wire (OPGW) is applied in the HV line for telecommunications, the SWS can be realized as well by insulating the OPGW for the operation voltage of

- the SWLs (application is under way in Togo and Benin).
- SWLs have practically no environmental impact. Independent MV lines on same ROW of an HV line require widening of ROW and cause more disturbances to forestry and farming.
- SWLs have proven to be a deterrent to vandalism and theft of HV lines, because the communities along the HV line must preserve the integrity of the line to ensure power supply to themselves from the SWL.
- Insulation of SW(s) for application of SWSs is compatible with power line carrier telecommunication, used in the HV lines in Ethiopia.
- The low values of short circuit currents in Ethiopia limit to well acceptable values the overvoltages induced in the SWLs during the asymmetrical phase-to-Gr faults in the associated HV circuit and the touch and step voltages near the grounding systems of HV towers with insulated SWs dispersing the short circuit currents.

The first SWS application in Ethiopia has been made in the Ghedo-Nekempte-Ghimbi 200 km long, 132kV line. The Single-Phase Earth-Return SWS (Fig. 1-A) was implemented and has been commissioned in 2003.

The second, more extensive, application of the SWSs is being performed along the following transmission lines: Gibel Gibe-Walkite 230 kV single-circuit line, 71 km long; Jimma-Bonga 132 kV double-circuit line, 103 km long; Bonga-Mizan 132 kV double-circuit line, 89 km long. The Jimma-Bonga-Mizan radial lines cross tropical regions, partly at high altitude (up to 2300 m), in areas of high keraunic level; they have therefore been effectively protected by two SWs with very low shielding angle. The "3-Phase" SWS (Fig. 1-D) has been applied in all these new lines. The "3-Phase" SWSs will be commissioned at the end of year 2005.

### 3.2 "Single-Phase Earth-Return" SWSs

The first application of the SWS in Ethiopia has been decided in 1998-99, for the Ghedo-Nekempte-Ghimbi 132 kV single-circuit line, which was under construction. The line had been designed with triangular configuration of phase conductors and lightning protection by one galvanized steel SW ( $d=10$  mm;  $S=60$  mm<sup>2</sup>). When the decision of implementing the SWS was made, towers had already been manufactured and partly erected; wire stringing had not yet started. The only practicable solution was therefore the application of the "Single-Phase Earth-Return" SWS, with the following minor changes of line design:

- i) Use of an ACSR SW, with cross-section of 76.9 mm<sup>2</sup> ( $S_{Al}=48.57$  mm<sup>2</sup>;  $S_{St}=28.33$  mm<sup>2</sup>; formation 12x2.27 mm wires of Al + 7x2.27 mm wires of galvanized steel; diameter  $d=11.35$  mm;  $r_{20^{\circ}C}=0.598$   $\Omega$ /km), instead of the galvanized steel SW.
- ii) Use in suspension towers of post-type fibreglass-silicone rubber composite insulators with arcing horns, to be bolted on the top plate of the tower SW peak by using the same four holes available for fitting the SW clamp (see Fig. 2a).

- iii) In tension towers, use two composite tension insulator strings and a light post-type composite insulator for supporting the jumper (Fig. 2b).
- iv) The down-lead from the insulated ACSR SW to the short lines supplying the villages, is made with an AAAC conductor supported by light post-type insulators fastened in the center line on one transversal face of the tower.

Check of tower structural design showed that modifications i) and ii) above were feasible without violating the specified safety factors of tower mechanical design. Use of composite insulators warrants mechanical withstand in case of broken SW. In suspension towers, the shielding angle of ACSR SW was slightly reduced due to 65 cm increase of height (Fig. 2a).

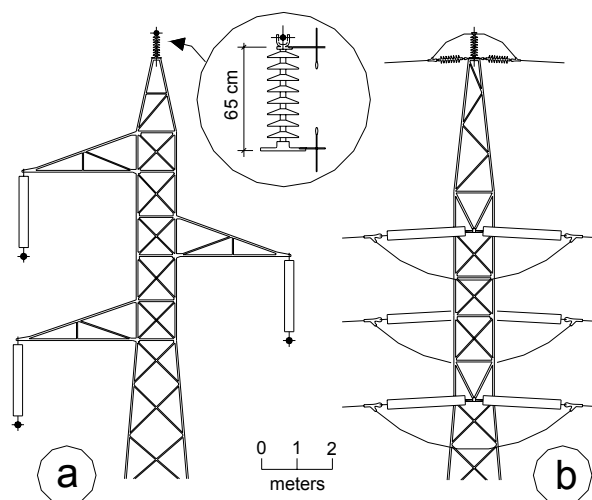

Fig. 2 – Addition of composite insulators for insulation of shield wire on Ghedo-Nekempte-Ghimbi 132 kV line

The tower grounding resistance and substation grounding mesh resistance, originally specified by EEPKO not to exceed 10 $\Omega$  and 1 $\Omega$ , respectively, are also satisfactory for line operation with insulated SW and for earth return of current. The three "Single-Phase Earth-Return" SWSs in operation in Ethiopia supply 15 villages and small towns via MV/LV single-phase transformers rated at 50, 100 and 200 kVA. Fig.3 shows some details of the single-phase SWSs.

Power supply in the villages is performed with the principles shown in Fig.7, however applied for single-phase distribution. The p.f. correction-antiferroresonance capacitors are pole mounted in the locations shown in Fig. 3.

Each SWL is supplied via an interposing transformer with ratio 15kV/34.5kV $\pm$ 2x3.75%, rated at 3 MVA.

The LV winding of MV/LV single-phase transformers is split in two series-connected sections (Fig. 1-A), providing 230 V between each energized terminal and the grounded mid-terminal, and 460 V between the two energized terminals. LV distribution lines are built with 3 conductors and customers are alternatively connected to the two 230 V circuits, to reasonably balance the loads.

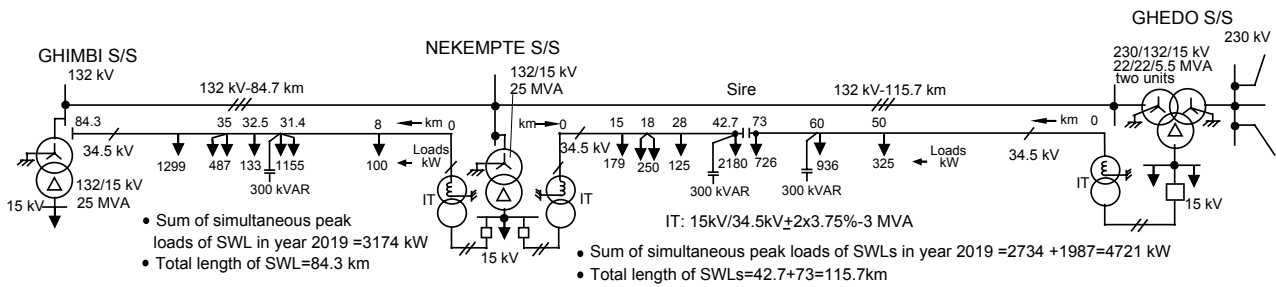

Fig. 3 - Single-Phase Earth-Return SWLs in operation on the Ghedo-Nekempte-Ghimbi 132 kV lines

Then current is very small in neutral wire and the reach of the 2x230 V line, that is controlled by voltage drop, is close to the reach of a 460 V line.

When the load of the single-phase SWLs will exceed 50% of final design load, a static L-C circuit may be connected to the 15kV busbars which supply the SWLs, to produce negative sequence currents in phase opposition with the negative sequence currents caused by the single-phase loads of SWLs, thereby minimizing the voltage unbalance on the supply network [3]. A typical circuit consists of two capacitors and one reactor, delta connected, performing also p.f. correction to unity; total kvar rating of capacitors and reactor will be about 50% of SWL load.

### 3.3 “3-Phase” SWSs

Details of the “3-Phase” 34.5 kV SWSs under construction in Ethiopia at the time of writing are provided in Fig. 4. The Walkite-Gibel Gibe SWS (Fig.4-a) is being implemented in a 230 kV single-circuit line, which is part of the 200 km long line connecting the Gibel Gibe hydroelectric power plant (HPP) to Addis Ababa. This line had been built with one galvanised steel SW, some years before the commissioning of the HPP. To allow supply by the SWL of several irrigation pumps rated each at about 100 kW in the Gibe state-owned farm, it has been deemed necessary to provide a 3-phase supply.

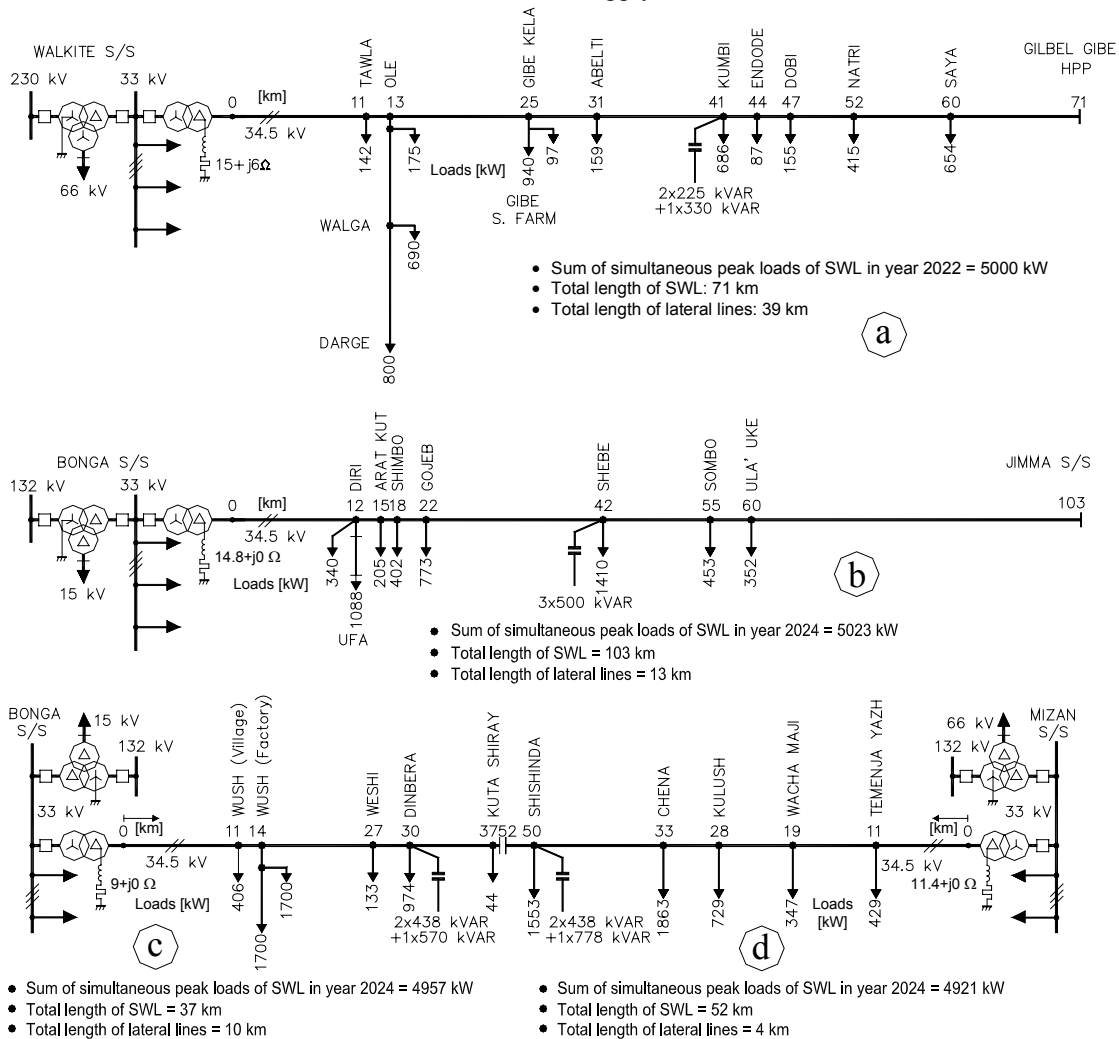

Fig. 4- Single-line diagrams of 34.5 kV “3-Phase” SWSs under construction in Ethiopia

Table I- Results of steady-state operation analysis of Walkite - Gibel Gibe SWS

Active power flow on 230 kV circuit				65 MW	130 MW	130 MW			
SWL load in % of year 2022 peak load of 5000 kW				10%	50%	100%			
Load power factor on LV side of MV/LV transformers				0.9	0.9	0.9			
Node	Village/Town	Year 2022 peak load [kW]	Distance from Walkite [km]	Phase-to-neutral positive sequence voltage, $V_1$ , and voltage unbalance $K_v=100V_2/V_1$ on LV side of MV/LV transformers					
				$V_1$ [V]	$K_v$ [%]	$V_1$ [V]	$K_v$ [%]	$V_1$ [V]	$K_v$ [%]
1	Tawla	142	11.2	235.1	0.20	229.3	0.28	231.7	0.74
2	Ole	175	13.2	235.3	0.20	231.9	0.17	231.3	0.52
3	Walga	690	13.2	229.2	0.24	230.4	0.11	234.2	0.31
4	Darge	800	13.2	229.0	0.27	229.4	0.21	232.2	0.40
5	Gibe Kela	97	24.8	230.2	0.28	231.4	0.19	234.8	0.12
6	Gibe S. Farm	940	24.8	230.0	0.28	230.3	0.20	232.6	0.19
7	Abelti	159	30.5	230.3	0.37	230.1	0.34	231.4	0.34
8	Kumbi	686	41.1	231.1	0.57	230.4	0.60	230.5	0.76
9	Endode	87	43.9	231.4	0.58	231.3	0.63	232.2	0.82
10	Dobi	155	46.7	231.1	0.59	229.9	0.66	229.2	0.91
11	Natri	415	52.0	231.3	0.62	230.1	0.72	229.3	0.97
12	Saya	654	60.1	231.3	0.65	230.0	0.79	228.6	0.99
Total peak load [kW]		5000							
Transformers' tap position: 230 kV±8x1.25%/66 kV/33 kV 33 kV/35.5 kV±2x3.75% MV/LV 34.5 kV±2x2.5%/400-231 V				+2x2.5% -1x3.75% +2.5%	0% 0% 0%	-1x2.5% +1x3.75% -1x2.5% or -2x2.5%			
Grounding impedance located at Walkite: $Z_c$				15 + J 6 Ω	15 + J 6 Ω	13 + J 5 Ω			
P.f. correction-antiferroresonance-balancing capacitors located at Kumbi:				$C_{w,gr} = 2x225 \text{ kvar}$ ; $C_{w,w} = 1x330 \text{ kvar}$					

Check of structural analysis of line towers has shown the possibility of replacing the single galvanised steel SW with two ACSR SWs of same type used in the Ghedo-Nekempe-Ghimbi line (see Par. 3.2), without violating the specified mechanical safety factors.

By taking advantage of the fact that the line was not yet energized, the tower shield wire peaks have been replaced with new ones having the design as shown in the middle-right design of Fig. 1. Then the two ACSR SWs have been strung, using rigid toughened glass insulator strings (Fig. 5), formed by 4 discs, with diameter of 254 mm, spacing of 120 mm, with the distance between the arcing horns set at 365 mm for altitude ≤ 2000m.

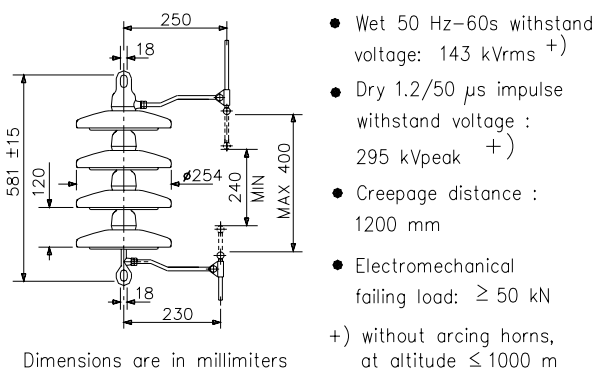

Fig. 5-Rigid toughened glass insulator string for 34.5 kV “3-Phase” SWS

The “3-Phase” SWSs of Fig. 4-b, c and d are being implemented in the 132kV double-circuit Jimma-Bonga and Bonga-Mizan lines, about 190 km long. These lines have been designed with two ACSR SWs of same type used in the other Ethiopian SWSs (see Par. 3.2), with shielding angle not

exceeding 10°. Initially, only one 132kV circuit has been strung, except in a stretch of 22km near Jimma. Lines are routed at altitudes between 1600m and 2300m.

At Wash-Wash, the SWS shall supply the largest tea processing plant of Ethiopia, employing 4000 workers, with an almost continuous load at full production of 2500 kW. At present the factory is supplied by two diesel stations with suppressed load.

The aggregate forecast peak load to be supplied by the four SWSs of Fig.4 is 21,000 kW in year 2024. After the year 2022 the Walkite-Gilbel Gibe SWL shall have to be split in two SWLs of about half length, to be independently supplied from the two terminal HV/MV substations. Splitting the SWLs in two parts shall be simply achieved by removing the jumpers of SWs in a tension tower.

Location and preliminary ratings of the L-R grounding circuits and of shunt capacitors, and forecast loads are shown in the single-line diagrams of Fig.4.

Table I summarizes the results of the steady-state operation analysis of the Walkite-Gilbel Gibe “3-Phase” SWS. It shows that the voltages at the LV terminals of the MV/LV transformers are well regulated in all locations and loading conditions. The negative-sequence component voltages, 100( $V_2/V_1$ ), have been calculated by assuming that the HV grid supply voltages are balanced. Table I shows that the calculated unbalance does not exceed 1 % at 10%, 50% and 100% of maximum load. A similar performance has been computed for the other “3-Phase” SWSs.

Short circuit and temporary overvoltage analyses have been performed with the program described in par. 2. Switching and lightning overvoltage analyses have been performed with the ATP-EMTP.

The HV/MV step-down transformers of the substations supplying the SWSs had already been procured when the

decision was made of applying the SWSs. It was thus not possible to use an ad-hoc tertiary winding of main transformers for supplying the SWLs. Standardized 3-phase interposing transformers (ITs) are therefore being installed, with no-load ratio  $33\text{kV}/35.5\text{kV} \pm 2 \times 3.75\%$  (off-load tap-changer), rated power of 5MVA, connection group star/delta with one terminal of delta winding permanently grounded via an L-R circuit.

Fig.6 shows the single-line diagram of the standard SWL supply bay. Each SWL is switched as one block with the relevant IT, by means of a 33kV CB installed on the primary supply side of IT, performing also the automatic reclosure.

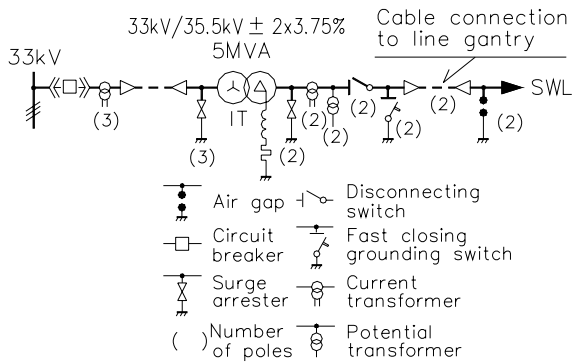

Fig. 6- Single-line diagram of the 34.5 kV supply bay of "3-Phase" SWLs

There is no CB on the 34.5kV SWL terminals. The IT is therefore specified to have the 33kV supply winding external (34.5kV winding close to core) and to withstand the

electro-dynamic forces caused by energization on 33kV side with the 34.5kV terminals accidentally short circuited.

Fig. 7 describes a typical distribution arrangement in a village. It shows how multiple grounding is realized for an economic and efficient limitation of grounding resistance and of touch/step voltages. Fig. 7 also shows that neutral of LV networks is grounded only in poles along the LV lines to realize separation with the grounding systems for earth return of current.

At take-off from the HV line, each lateral line to a village is sectionalized by a bipolar disconnecting switch and protected by two HRC type fuses with replaceable silver fuse link.

The MV/LV transformers are pole mounted (see Fig. 7), sectionalised and protected by two single-phase fused cut-outs. LV feeders are protected by fuses. Many of the initially installed MV/LV transformers are rated at 100 kVA; some are rated at 200 kVA and 315 kVA. In the tea-processing plant, pedestal mounted 630 kVA or 800 kVA transformers will be installed.

Long MV lateral lines are equipped with two conductors and are designed with longer spans than 3-wire MV lines. The 3rd ground conductor is installed only in 0.5-1 km of lateral line close to the MV/LV transformer stations, to perform the multiple grounding for earth return of current (a grounding rod every 3 poles, paralleled by the overhead ground conductor, see Fig.7).

Lateral lines are exposed to transient and permanent faults as conventional MV lines. In order to achieve a low outage rate of the SWL, it is necessary to ensure a good coordination of the protection relays supervising the 33 kV CB at sending end of SWL, of fuses at take off from SWL and of fuses protecting the MV/LV transformers.

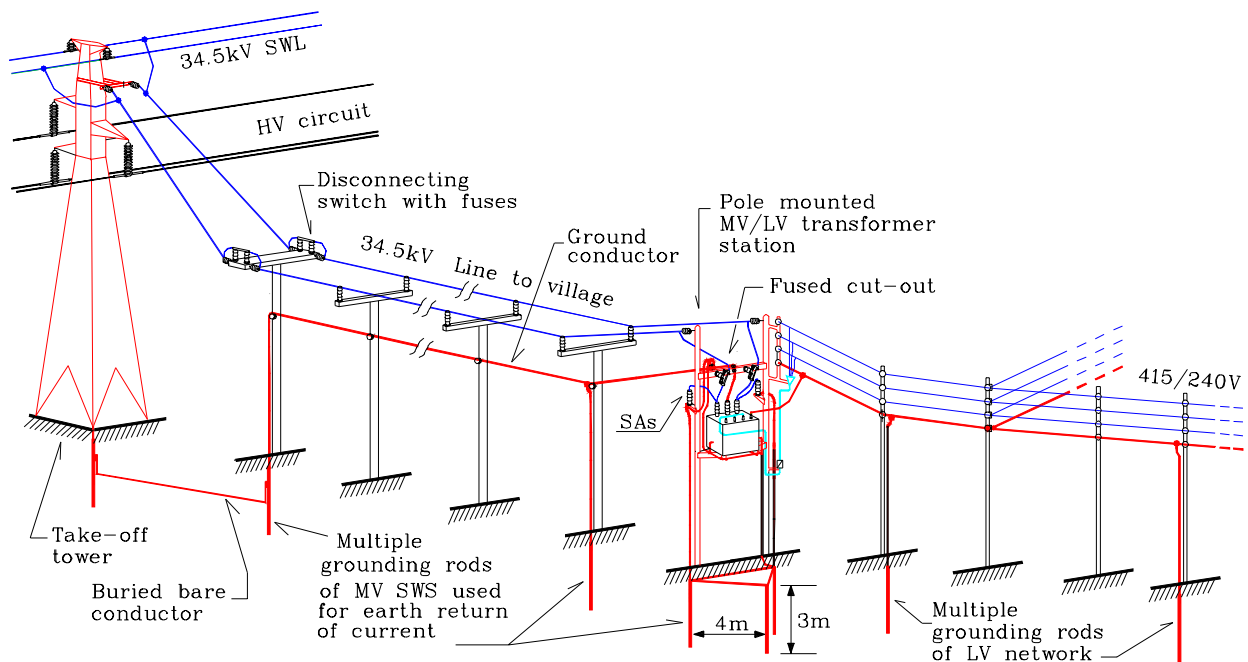

Fig. 7- Circuit schematic of "3-Phase" SWS distribution in the villages, showing independent earthing of MV and LV networks



#### 4. OPERATION EXPERIENCE

The "Single-Phase Earth-Return" SWSs have provided a well regulated and stable voltage (220-230 V) to consumers, also during start-up of the largest motors. However, customers using motor drives prefer the 3-phase supply, because single-phase motors are not available in the local market. According to the new expansion plan of rural electrification in Ethiopia, single-phase distribution systems will be widely applied for small rural load centers. It is thus believed that single-phase motors will become available in the market. On the other hand, as time goes by, the number of customers and load are increasing. Then the distribution capacity of the single-phase schemes, that is smaller than the capacity of "3-Phase" SWS, may become insufficient for semi-urban areas and large agricultural loads. EEPCO has decided to apply the "3-Phase" scheme in the 2<sup>nd</sup> SWS project, to enable supply of large agricultural loads and food processing plants.

The SWLs are switched on and off as conventional MV lines, with all the distribution transformers connected.

Checking of the adequacy of grounding systems for earth return of current is very simple in a SWS in service, because there is a continuous current injection to the ground,  $I_g$ . It is therefore sufficient to measure  $I_g$  with a clamp-on ammeter in the villages and substations, and the potential to remote earth,  $V_e$ , with a multimeter. The ratio  $R_g = V_e / I_g$  is the ground resistance. Touch and step voltages are measured with a multimeter and readily recalculated for the maximum design current,  $I_{g,max}$ , by multiplying by the ratio  $I_{g,max} / I_g$ .

No permanent faults have occurred so far in the SWLs.

Transient faults on SWLs can be caused almost solely by lightning. Owing to the location on top of towers, energized SWs cannot undergo arcing to vegetation; the wire-to-wire faults that are caused by wind, birds etc. in conventional MV lines, are not possible in the 2-wire earth-return SWLs, due to the large distance between the two SWs; bush fires, if any, affect HV conductors rather than SWs.

The recorded rate of faults per 100km×year is lower for the SWLs in operation than for conventional MV lines of same rated voltage, in spite of the higher exposure to lightning of SWLs. The automatic high-speed reclosure of SWLs has been successful following the vast majority of recorded faults.

#### 5. APPLICATIONS OF SWSs IN OTHER COUNTRIES

**Ghana.** The first pilot and commercial applications were made in Ghana in the late 1980s. About 1000 km of 161 kV-50 Hz transmission lines are provided with SWSs, half of which have been in operation for 15 years (30 kV "3-Phase" and 34.5 kV "V" SWSs). The good operational experience has justified the application in other countries, in most cases supported by the International Funding Agencies.

**Brazil.** "3-Phase" SWSs have been in operation since 1995 in a long 230 kV-60 Hz line. One of the SWSs supplies the town of Jaru (initial load was 4.3 MW in 1995) located at a distance

distance of 85 km from the supply substation of the SWL.

**Sierra Leone.** "3-Phase" 34.5 kV SWSs have been implemented in 150 km of the first 161 kV-50 Hz line of the country. One SWL will supply 4.5 MW to the town of Makeni and will be used for power line carrier communications. The 161 kV line and associated SWSs are not yet in service due to turmoil in the country.

**Laos.** Three "Single-Phase Earth-Return" 25 kV SWSs are in service since 1996 in 185 km of 115 kV-50 Hz lines. Five "3-Phase" 34.5 kV SWSs are in service since 2002-03 in 310 km of 115 kV-50 Hz lines. These SWSs supply about 150 villages and towns

**Togo.** "3-Phase" 34.5 kV SWSs are under construction in 265 km of new 161 kV-50 Hz lines. One of the SWs will be an insulated OPGW.

**Benin.** "3-Phase" 34.5 kV SWSs are under implementation in about 300 km of 161 kV-50 Hz lines. One of the SWs will be an insulated OPGW.

**Burkina Faso.** "3-Phase" 34.5 kV SWSs are planned for construction in a new 225kV-50Hz-330 km long line.

**Mozambique.** A feasibility study has been performed for the application of "3-Phase" 34.5 kV SWSs in about 550 km of existing 220 kV lines in the North of the country.

**Zimbabwe.** A prefeasibility study has been made for application of 34.5 kV "3-Phase" SWSs in about 400 km of 330 kV new lines.

**Cambodia and Malawi** have also expressed interest in the use of the SWSs.

#### 6. CONCLUSIONS

The unconventional grid based rural electrification technique dealt with in the paper, referred to as the SWS, allows electricity to be made available at MV to communities located along the HV transmission lines, with an installation cost that is only 10-15% of cost of independent MV lines on the same ROW. Environmental impact and maintenance costs of SWLs are negligible.

15 years of operational experience in Ghana and several years of experience in other developing countries have confirmed the viability of SWSs, which provide a quality of service to consumers not inferior to the one of equivalent conventional MV lines. On the basis of this field experience, the Ethiopian Electric Power Corporation has put in operation in 2003 three "Single-Phase Earth-Return" SWSs and will commission at the end of the 2005 four "3-Phase" SWSs serving a large rural population in very productive agricultural regions.

The "3-Phase" SWS provides a well regulated and balanced 3-phase supply in all locations. Earth return of current does not pose problems. Faults on SWLs are practically all of transient nature, generally caused by lightning. The use of the automatic reclosure is expected to eliminate the vast majority of faults.

No royalties are due for application of SWSs, which have been conceived for promoting rural electrification in developing countries.

## 7. REFERENCES

- [1] F. Iliceto - "*Lightly Loaded Long HV Transmission Lines. Guidelines prepared at the request of the World Bank*", Washington D.C., 1982-83.
- [2] F. Iliceto, E. Cinieri, L. Casely-Hayford, G. Dokyi, - "New Concepts on MV Distribution from Insulated Shield Wires of HV lines. Operation results of an experimental system and Applications in Ghana", *IEEE Transactions on Power Delivery*, Vol.4, N°4, October 1989, pp. 2130-44.
- [3] F. Iliceto, E. Cinieri, F.M. Gatta - "Rural Electrification of Developing Countries Using the Insulated Shield Wires of HV lines. New Design Criteria and Operation Experience", *CIGRE* paper 37/38-03, 1994 Session, Paris.
- [4] F. Iliceto, F.M. Gatta, S. Lauria, G. Dokyi - "Three-Phase and Single-Phase Electrification in Developing Countries Using the Insulated Shield Wires of HV Lines Energized at MV", *CIRED* paper N° 5/p10, 1999 Session, Nice (France).
- [5] F. Iliceto, F.M. Gatta, G. Dokyi - "Three-phase and single-phase electrification in developing countries using the insulated shield wires of HV lines energized at MV. Operation experience in Ghana", *IV International Conference on Power Systems Operation and Planning*, Accra (Ghana), July-August 2000, Paper N° 20-2E01.
- [6] A. D'Ajuz, A.M. Araiyo, E. Montalvao, G. Machado, E. Mendes, F. Iliceto, F.M. Gatta, E. Cinieri - "Linhas de transmissao com cabos para-raios energizados- Uma solucao economica para o suprimento a comunidades isoladas". *XII SNPTEE, the Power System Brazilian Conference*, Recife, Oct. 1993.
- [7] F.M. Gatta, F. Iliceto, S. Lauria - "Lightning performance of HV transmission lines with insulated shield wire(s) energized at MV. Analysis and field experience", *CIGRE Symposium*, Cairns (Australia), Sept. 2001, Paper 100-07.
- [8] F.M. Gatta, F. Iliceto, S. Lauria, P. Masato - "Analysis of unsymmetrical transmission-distribution systems. Applications to insulated Shield Wire Schemes", *L'Energia Elettrica*, Vol. 79, N° 5, September-October 2002.
- [9] F.M. Gatta, F. Iliceto, S. Lauria - "Lightning performance of HV transmission lines with grounded or insulated shield wires", *ICLP 2002 – 26th International Conference on Lightning Protection*, Cracow (Poland), September 2-6, 2002, Paper 6b.5.
- [10] E. Cinieri, F. Iliceto, G. Dokyi - "A New Method for the Analysis of Power Distribution Schemes at MV Using the Insulated Shield Wires of HV lines. Operation Results in Ghana". *Africon 1992*, Swaziland, Sept. 1992, paper A-054.
- [11] F. Iliceto, F.M. Gatta, P. Masato, H. Sysoulath - "Rural Electrification in Developing Countries with the Shield Wire Scheme. Applications in Laos", *CIGRE* paper C6-301, 2004 Session, Paris.