

Searching for biomarkers of acute rejection in renal transplant recipients – development and optimization of a urinary proteomic approach

Thesis for the degree of Philosophiae Doctor

by

Håvard Loftheim



Department of Pharmaceutical Chemistry and Department of Pharmaceutical
Biosciences

School of Pharmacy

Faculty of Mathematics and Natural Sciences

University of Oslo

Norway

© Håvard Loftheim, 2011

*Series of dissertations submitted to the
Faculty of Mathematics and Natural Sciences, University of Oslo
No. 1108*

ISSN 1501-7710

All rights reserved. No part of this publication may be
reproduced or transmitted, in any form or by any means, without permission.

Cover: Inger Sandved Anfinsen.
Printed in Norway: AIT Oslo AS.

Produced in co-operation with Unipub.
The thesis is produced by Unipub merely in connection with the
thesis defence. Kindly direct all inquiries regarding the thesis to the copyright
holder or the unit which grants the doctorate.

TABLE OF CONTENTS

ACKNOWLEDGEMENTS

LIST OF PAPERS

ABSTRACT

LIST OF ABBREVIATIONS

1	Introduction	1
1.1	Kidney transplantation	2
1.1.1	Kidney transplantation in general and the status in Norway	2
1.1.2	Acute rejections	3
1.2	Proteomics	4
1.2.1	Sample preparation in urinary proteomics.....	5
1.2.2	Proteolytic digestion of proteins	6
1.2.3	LC-MS/MS of proteins/peptides.....	7
1.2.4	Quantification in urinary proteomics.....	12
1.2.5	Data acquisition	15
2	Aim of the study	18
3	Results and discussion	19
3.1	Sample preparation and separation in urinary proteomics	19
3.1.1	Sample collection and storage	20
3.1.2	Sample preparation.....	20
3.1.3	Chromatographic separation of the peptides.....	23
3.1.4	Variability of the method: step by step evaluation of the workflow	27
3.2	Tryptic digestion & protein identification	28
3.2.1	Optimization of digestion conditions using immobilized trypsin beads.....	28
3.2.2	In-solution digestion vs. digestion on immobilized trypsin beads.....	29
3.2.3	Digestion efficiency in human urine	30
3.2.4	On-column reduction, alkylation and tryptic digestion	31

3.2.5	Protein identification by different analytical platforms	32
3.3	Accelerated quantification in urinary proteomics utilizing ¹⁸O-labeling.....	33
3.3.1	pH dependency and reaction time optimization	34
3.3.2	Integration of digestion and labeling using immobilized trypsin beads	36
3.3.3	Efficiency of the optimized procedure in urine samples.....	39
3.4	Differential expressed proteins following acute rejection in renal transplant recipients	42
3.4.1	Choice of patients and samples	42
3.4.2	Up-regulated proteins	43
3.4.3	Comparison with earlier published data.....	51
3.5	Future perspectives	51
4	Concluding remarks	53
5	References.....	55

ACKNOWLEDGEMENTS

The presented work was performed at the department of Pharmaceutical Chemistry and the department of Pharmaceutical Biosciences, School of Pharmacy, University of Oslo in cooperation with both the department of Transplant Medicine at Oslo University Hospital and the department of Chemistry, University of Oslo.

First of all I would like to thank my two supervisors Professor Léon Reubsaet and Professor Anders Åsberg. I am very grateful for the opportunity to work under your guidance in the borderline between two exciting research fields. Thank you for your great support and enthusiasm; during these four years I have always been at my most inspired after having meetings with you, seeing new opportunities and eager to test our new ideas in the laboratory.

I would like to thank my co-authors Thien Nguyen, Bjørn Winther, Bao Tran, Helle Malerød, Elsa Lundanes, Tyge Greibrokk, Jadranka Vukovic, Karsten Midtvedt, Anders Hartmann, Anna Varberg Reisæter, Pål Falck, Hallvard Holdaas and Trond Jenssen for your valuable contribution to the work. A special thanks to my master students Thien, Malin and Tam; you have made important contributions to my research.

I would also like to thank my colleagues for creating a great social working environment. Your company has been much appreciated whether it has been in the laboratory or at congresses and department trips.

Finally a warm thank you goes to my lovely wife Ragna for all the support you have given me during this work. Spending time with you and our wonderful children Mari and Sverre will always be the highlight of the day. You always make me smile when I come home regardless of how bad the mass spectrometer has treated me during the day.

Oslo, August 2011

Håvard Loftheim

LIST OF PAPERS

- I Loftheim H, Nguyen TD, Malerød H, Lundanes E, Åsberg A and Reubsæet L.
*2-D hydrophilic interaction liquid chromatography-RP separation in urinary proteomics
– Minimizing variability through improved downstream workflow compatibility*
Journal of Separation Science 2010, 33: 864-872
- II Vukovic J, Loftheim H, Winther B and Reubsæet JLE.
*Improving off-line accelerated tryptic digestion. Towards fast-lane proteolysis of complex
biological samples*
Journal of Chromatography A 2008, 1195: 34-43
- III Tran BQ, Loftheim H, Reubsæet L, Lundanes E and Greibrokk T.
*On-Line multitasking analytical proteomics: How to separate, reduce, alkylate and digest
whole proteins in an on-line multidimensional chromatography system coupled to MS*
Journal of Separation Science 2008, 31, 2913-2923
- IV Loftheim H, Åsberg A and Reubsæet L.
Accelerated ¹⁸O-labeling in urinary proteomics
Journal of Chromatography A 2010, 1217, 8241-8248
- V Loftheim H, Midtvedt K, Hartmann A, Reisæter AV, Falck P, Holdaas H, Jenssen T,
Reubsæet L and Åsberg A.
*The use of a urinary proteomic shotgun approach to search for potential biomarkers of
acute rejections in renal transplant recipients*
Manuscript submitted

ABSTRACT

In *Paper I* a method for sample preparation of urinary proteins was developed and optimized. The main steps were desalting/enrichment by cut-off centrifugation (5 kDa), albumin depletion and tryptic digestion followed by 2D-LC-MS. Emphasize was put on maximizing protein recovery and improving downstream compatibility. A 2D-separation approach combining ZIC-HILIC and RP was also tested and gave a separation system with a high degree of orthogonality. Finally, the suitability of the method was assessed in a comprehensive proteomic experiment using urine from renal transplants. A high number of urinary proteins were identified and the variability of the whole method was in the range of 11 to 30 % (RSD).

In *Paper II* enzymatic digestion using immobilized trypsin beads was investigated. Evaluation of different reactor formats and conditions like digestion temperature and reaction time were carried out to find the optimum setup. Larger proteins demanded longer digestion time and BSA was digested in 89 minutes at 37 °C. The optimized procedure was compared with digestion *in-solution* with respect to time consumption, sequence coverage and degree of unsuccessful cleaving. The final digestion set-up was carried out in urine samples yielding good signal intensities and reproducibility.

In *Paper III* a multidimensional on-line system including Strong Anion Exchange Chromatography (SAX) separation of native proteins, reduction, alkylation, C4 separation and tryptic digestion of the alkylated proteins followed by MS detection was tested as an alternative to the off-line method developed. Proof of concept was shown and the efficiency of the reduction and alkylation was equivalent with established methods. On-line tryptic digestion was satisfactory for several proteins but needs further optimization to cover the full proteome. The system was evaluated using both model proteins and human urine sample and has shown potential as a tool to identify biomarkers offering short analysis time and minimum manual sample handling.

In *Paper IV* proteolytic ¹⁸O-labeling of peptides was investigated and improved in order to optimize the labeling efficiency and accelerate the process. Optimization was carried out using BSA and cyt *c* as model proteins and the best efficiency was achieved at pH 6 yielding

complete labeling during 2 hours at 37 °C with immobilized trypsin beads. An approach integrating tryptic digestion developed in *Paper II* with ^{18}O -labeling, both using immobilized trypsin beads was also developed. This enabled tryptic digestion and ^{18}O -labeling by 3.5 hours, without any sample transfer steps. The procedure was evaluated in urine, first by spiking it with model proteins and then by analyzing the true human urinary proteome after implementation in the workflow developed in *Paper I*.

In *Paper V* the method developed in *Paper I, II* and *IV* was used to identify urinary proteins associated with acute rejection episodes in kidney transplanted patients. A large degree of regulation was found and 11 proteins were identified as up-regulated in the rejection group (n=6) compared with the control group (n=6) according to strict criteria. The up-regulated proteins could be grouped by biological function in 2 main groups; proteins involved in growth and proteins involved in immune response. The growth proteins were statistically significantly up-regulated ($P=0.03$) while the immune proteins only showed an overall trend towards up-regulation in the rejection group compared with the control group ($P=0.13$).

LIST OF ABBREVIATIONS

2-DE	Two-Dimensional Gel Electrophoresis
ABC	Ammonium Hydrogen Carbonate
AR	Acute Rejection
BPAR	Biopsy Proven Acute Rejection
BSA	Bovine Serum Albumin
CID	Collision Induced Dissociation
CsA	Cyclosporine A
CV	Coefficient of Variation
cyt <i>c</i>	Cytochrome C
DD	Deceased Donor
EGF	Epidermal Growth Factor
ELISA	Enzyme-Linked Immunosorbent Assay
EMBL	The European Molecular Biology Laboratory
ESI	Electrospray Ionization
HILIC	Hydrophilic Interaction Liquid Chromatography
HSA	Human Serum Albumin
ICAT	Isotope-Coded Affinity Tags
IGFBP7	Insulin-like Growth Factor-binding Protein 7
IL-6	Interleukin-6
IP-10	IFN- γ -inducible Protein 10
IPI	International Protein Index
iTRAQ	Isobaric Tags for Relative and Absolute Quantification
LC	Liquid Chromatography
LD	Living Donor
MALDI	Matrix-Assisted Laser Desorption Ionization
MASP2	Mannan-Binding Lectin Serin Protease 2
MeCN	Acetonitrile
MIF	Macrophage Migration Inhibitory Factor
MRM	Multiple Reaction Monitoring
MS	Mass Spectrometry
MS/MS	Tandem Mass Spectrometry

<i>m/z</i>	Mass-to-charge ratio
NCBI	National Center for Biotechnology Information
PMF	Peptide Mass Fingerprinting
RP	Reversed Phase Chromatography
RRT	Renal Replacement Therapy
RSD	Relative Standard Deviation
SAX	Strong Anion Exchange Chromatography
SCX	Strong Cation Exchange Chromatography
SEC	Size Exclusion Chromatography
TCA	Trichloroacetic Acid
TGF- β_1	Transforming Growth Factor-beta
TOF	Time of Flight
TMT	Tandem Mass Tags
UniProtKB	UniProt Knowledgebase
VEGF	Vascular Endothelial Growth Factor
ZIC	Zwitterionic

1 Introduction

Solid organ transplantation is a unique treatment option for organ failure where the failing organ function is replaced by organs obtained from either a living or deceased donor. The organs most frequently transplanted are; kidney, heart, lungs and liver. Most of the transplants are performed between genetically non-identical individuals, where the immune response of the recipient against the foreign graft is one of the principal obstacles to a successful transplantation. This immune response is generally referred to as a rejection. Acute rejection (AR), which is subcategory, predominately appears the first 3 months post-transplant, but can also emerge after several years. All patients are treated with a cocktail of immunosuppressive drugs to inhibit the immune reaction. This is usually a lifelong treatment. In order to control this immune response, serotyping is performed to determine the best donor/recipient (antigen) match possible.

Transplanted patients need to be continuously monitored for immune activation and acute rejections, especially during the early phase after transplantation. Currently, acute rejection episodes are suspected upon sudden decrease in renal function, without other plausible explanation, and verified by kidney biopsies. Raised plasma creatinine levels as an indicator of AR is neither specific nor sensitive and might as well reflect other diagnosis, e.g. drug toxicity (cyclosporine A, CsA). A molecular biomarker (in this case, a protein), which could be used to diagnose AR more selectively and ideally at an earlier stage, would be of great value to improve the monitoring of these patients. Relevant adjustments of the immunotherapy could then be introduced earlier enough to possibly reverse the initiating AR and potentially avoid the use of highly toxic anti-rejection therapy.

Urine is one of the most attractive sources for biomarker search due to the non-invasive sampling procedure. The protein concentration in urine of healthy subjects is low (less than 100 mg/L) compared to other body fluids. Despite this, urinary proteomics seems very promising in the search for biomarkers and is a rapid growing field [1]. About 30 % of the proteins in urine originate from plasma while the remaining 70 % originate from the kidney [1,2]. Urine may therefore provide specific advantages for detection of local effects within the kidney, but also other functions of the body can be monitored since a large part of the urinary proteome derive from plasma. Recent development in the field of mass spectrometry and bioinformatics along with the DNA sequencing elucidating the

human genome has offered great possibilities to analyze the proteome of different body fluids.

1.1 Kidney transplantation

1.1.1 Kidney transplantation in general and the status in Norway

Renal transplantation is the ultimate renal replacement therapy (RRT) for most patients with end-stage kidney disease [3]. Genetic similarity to the recipient makes living relatives favorable donors, but since 1984 unrelated living donors have also been used. If no acceptable living donors are available, a good alternative is deceased donors. In Norway, all transplantation is performed at Oslo University Hospital (Rikshospitalet) where each renal transplant recipient is followed closely for about 3 months before they are transferred to their respective local nephrology center. The patients in the current study were in the early post-transplant phase and thus followed clinically at Rikshospitalet.

The last few years there has been a slight increase in number of transplantations in Norway and in 2009 a total of 292 renal transplants were performed at Rikshospitalet, which was a new all-time high [4]. Among these, 38 % of the patients received grafts from a living donor and 62 % from a deceased donor and 248 (92 LD and 156 DD) of these transplantations were the first transplant for the recipients. The mean age of the recipients from living donors were 46.9 years (range 1-78) while for those receiving from deceased donors the mean age was 57 years (range 14-80). The primary renal diseases which most frequently resulted in need of RRT were the following; vascular/hypertensive nephropathy (32 %), diabetic nephropathy (18 %) and glomerulonephritis (17 %) [4]. The graft and also patient survival has increased markedly the last 30 years. This is related to major changes in immunosuppressive therapy where especially the introduction of CsA based immunotherapy in 1983 improved survival. The observed two-year patient survival was 84 % for patients transplanted in the period of 2000-2004 while the five-year survival was approximately 70 % for the same group [5].

The basis immunosuppressive protocol at the hospital has since 2007 been quadruple treatment. This treatment includes mycophenolate, steroids, low dose calcineurin inhibitor (CsA or tacrolimus depending on several criteria e.g. age) in addition to induction therapy with i.v. basiliximab at the time of transplantation.

1.1.2 Acute rejections

Cause

Acute rejection is a serious and relative frequent complication after renal transplantation affecting long-term graft outcome. The allograft rejection is caused by several elements of the immune system including antibody, complement, T-cells and other cell types [6]. Mechanisms believed to be responsible are thoroughly reviewed by Cornell et al. [7], see Figure 1 for cells and mediators involved. T-cell-mediated acute rejection is characterized by accumulation of mononuclear cells (mostly T-cells) in the interstitium, accompanied by inflammation of tubules and sometimes arteries. Another variant of acute rejection is antibody-mediated rejection, differentiated by the presence of alloantibodies [8]. The pathology has however a wide spectrum and could also include a component of acute cellular rejection. In contrast to T-cell-mediated rejection, the alloantibodies preferentially attack the peritubular and glomerular capillaries, where accumulation of neutrophils and monocytes occur [8].

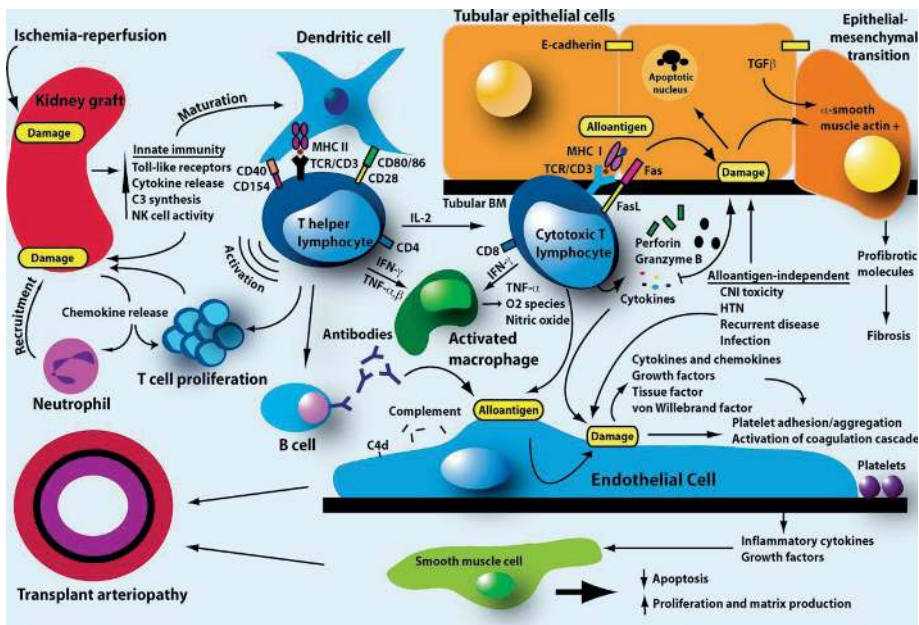

Figure 1. Overview of cells and mediators involved in acute rejection (from reference [6] with permission).

Diagnosis

Examination of immunological activity by histological analysis in renal biopsies is currently the gold standard for diagnosis of acute rejection episodes. This is carried out on suspicion of acute rejection, often made on basis of clinical symptoms of impaired renal function (elevated plasma creatinine levels). One of the challenges is that CsA and tacrolimus can give the same symptoms, but then as a result of high dosage. Paradoxically, increased plasma creatinine can thus be observed as a consequence of both over- and under-immunosuppression. The biopsies are classified according to the Banff criteria, which is a standardization of renal allograft biopsy interpretation based on international consensus. Classification is performed by using a scoring system determining type and severity of the AR and in the current study (*Paper V*), the Banff 97 criteria were used [9]. Antibody-mediated rejection type is identified by positive C4d staining in addition to other criteria [8].

Effect on outcome

The event of AR in renal transplants increases the risk of developing chronic allograft nephropathy and is also associated with reduced long-term survival [10-14]. Several factors including the timing and severity of the acute rejection episode and the post rejection recovery of renal function affects the chronic allograft injury [15-17]. Antibody-mediated rejections generally has worse prognosis and demands a different form of therapy than the usual T-cell-mediated rejection [8].

1.2 Proteomics

The proteome can be described as the protein complement of the expressed genome, including protein modifications occurring during and after translation [18]. Proteomics is the study of protein properties like expression levels, post-translational modifications, interactions etc. on a large scale to obtain a view of disease processes, cellular processes and networks at the protein level [19]. Detection of proteins using mass spectrometry (MS) can either be done by a top-down approach where intact proteins are analyzed or by a bottom-up approach where proteins are digested into smaller peptides prior to analysis. In this thesis, a bottom-up approach has been applied; the principal workflow is presented in Figure 2. As discussed more thoroughly in section 1.2.3, the bottom-up approach benefits from better mass detection and sensitivity of the resulting peptides compared with intact

proteins which are analyzed when using a top-down approach. The main steps, presented in the following sections, are sample preparation to isolate the proteins of interest from the matrix followed by digestion of the proteins into peptides using a specific protease with known digestion pattern. Further, the peptides are separated and detected by liquid chromatography coupled to MS. In addition, a quantification strategy has to be implemented somewhere in the workflow depending on the approach chosen. Finally, processing of the large amounts of data obtained is an essential part of the work in order to identify and quantify proteins.

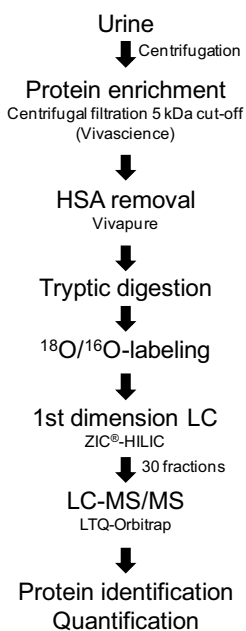

Figure 2. The main steps of the workflow developed in this thesis

1.2.1 Sample preparation in urinary proteomics

Urine is a less complex matrix than for instance plasma, especially with respect to protein content, but still requires sample preparation in order to obtain data of good quality from the LC-MS/MS analysis. Since the protein concentration in urine is relatively low, effective protein enrichment is advantageous in the sample preparation. Nevertheless, this should not be at the expense of high and repeatable protein recoveries to cover the whole

proteome and to ensure confident assessment of differential expressed proteins observed. In addition to this, the salt concentration in urine can be a challenge with regard to both LC-MS and gel electrophoresis, thus making effective desalting vital in the sample preparation. Several sample preparation methods have previously been described in the literature [20-23]. The methods evaluated include precipitation using different agents (e.g. organic solvents), lyophilization, ultracentrifugation and molecular weight cut-off centrifugation where both protein recoveries and the quality of the protein spots (gel electrophoresis) have been assessed. In this work, 5 kDa cut-off centrifugation and protein precipitation using ethanol and trichloroacetic acid (TCA) have been tested. Ethanol was chosen due to the high protein recoveries reported previously [20]. TCA and cut-off centrifugation were included to be able to compare different enrichment principles.

The dynamic range of protein concentrations in body fluids span several orders of magnitude, up to 10^{11} - 10^{12} in plasma [24,25]. The most valuable information, however, probably lies in the low abundant segment of the proteome and this is easily overshadowed by high abundant proteins like albumin and immunoglobulins [26]. Thus, depletion of proteins has become a standard approach for in-depth analysis of the proteome. Although depletion pretreatment could affect the recovery negatively and has shown to co-deplete other proteins, it has also been demonstrated to increase the total number of proteins identified [22,27]. In the case of urine some reports suggest that the problem with large dynamic range is not as severe as in plasma, and that protein concentrations are more evenly distributed [28]. Most depletion strategies are based on immuno-affinity, ranging from depletion of only human serum albumin (HSA) up to 20 of the most abundant proteins. There is a wide range of commercially available kits for such depletion.

1.2.2 Proteolytic digestion of proteins

After purification, isolation and enrichment of the proteins, the next step is digestion of proteins into peptides. This is an essential step of the bottom-up approach and is done by the use of enzymes cutting at specific sites on the protein generating predictable peptides of suitable length for the subsequent analysis by mass spectrometry [18,29]. Trypsin is the most widely used enzyme for this purpose, cleaving the proteins exclusively at the arginine and lysine residues, except when followed by proline [30,31]. This generally leads to shorter peptide sequences, which is favorable for MS detection compared with enzymes that only cleave at one amino acid residue. Tryptic digestion is usually preceded by

reduction and alkylation of the proteins to break the sulfide bridges that are present in most (large) proteins. This results in unfolding of the proteins to make the cleavage sites more accessible to trypsin, yielding a more efficient digestion. Tryptic digestion has traditionally been carried out *in-solution*, but lately much attention has been paid to digestion using immobilized trypsin using different carrier materials and formats [32-35]. There are several advantages offered by the use of immobilized trypsin: shorter reaction time, possible re-use of the enzyme and improved stability of the enzyme. In addition, the use of immobilized trypsin allows for automation as reviewed by Massolini and Calleri [36].

1.2.3 LC-MS/MS of proteins/peptides

Analysis of intact proteins demands high resolution MS equipment in order to achieve an acceptable mass accuracy in the high mass range where intact proteins are measured [37]. Since the mass accuracy is better in the low mass range, analysis of peptides allows for a better mass detection. Another drawback, particularly when electrospray ionization (ESI) is used, is that the intact proteins becomes multiple charged which reduces the sensitivity substantially as opposed to peptide ionization which have far less charge distribution. Furthermore, enzymatic cleavage of proteins into peptides increases the overall solubility of the sample, which is a clear advantage for the following analysis.

Separation by liquid chromatography

Separation of proteins has in proteomics routinely been done using two-dimensional gel electrophoresis (2-DE) followed by in-gel digestion prior to MS [2,38]. Although valuable information for protein identification is obtained (i.e. molecular weight, isoelectric point), the method suffers from poor recovery of hydrophobic and large proteins and labor-intensive operation. An alternative approach is the use of shotgun proteomics, where the sample is proteolytically digested in-solution prior to separation that is performed using liquid chromatography [39-41]. The challenge with this approach is the massively increased sample complexity due to all the peptides originating from a single protein after digestion. A reduction of the sample complexity prior to the mass spectrometric detection is usually necessary to secure good quality data and satisfying protein identification. To achieve this, several peptide separation strategies are often combined to increase the number of peptides possible to separate in the system.

Peak capacity is a theoretical term often used to describe the numbers of peaks (peptides) that can be separated in a separation system. The theoretical peak capacity in a 2D system is defined as the linear combination of the peak capacity in both dimensions [42]. The practical achievable peak capacity will however be limited by the orthogonality of the system, which means that if the two dimension of separation are not completely orthogonal (dissimilar), the achievable peak capacity is lower than theoretically expected. Several two-dimensional liquid chromatography (2D-LC) approaches have been developed including the most typical, strong cation exchange chromatography (SCX) coupled to RP, which also is used in urinary proteomics [43,44]. The most important strategy is referred to as multidimensional protein identification technology (MudPIT), where tryptic peptides are analyzed by multidimensional chromatography combined with mass spectrometry and search algorithms to identify proteins [45].

In the current work a 2D-LC approach using Hydrophilic Interaction Liquid Chromatography (HILIC)-RP has been applied. HILIC can be described as normal phase chromatography, but with aqueous-organic mobile phase where water is the strongest solvent. The mechanisms of retention are still debated, but present theories suggest a partitioning of the analyte between the mobile phase and a water-enriched layer in the hydrophilic HILIC stationary phase. In addition to this, other mechanisms involving ion exchange, electrostatic interactions, dipole-dipole interactions and hydrogen bonding are likely to be contributors to retention. Several HILIC stationary phases have been developed and can roughly be grouped as neutral (diol, amide), charged (plain silica, aminopropyl) and zwitterionic (sulfobetaine, silica- or polymerbound) phases. The zwitterionic (ZIC)-HILIC stationary phase was used in this thesis, where the active layer contains both strongly acidic sulphonate groups and strongly basic quaternary ammonium groups chemically bonded to silica as showed in Figure 3.

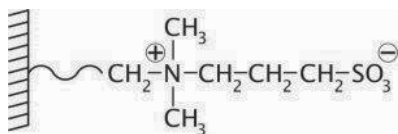

Figure 3. Structure of the ZIC-HILIC stationary phase

These groups strongly bind water by hydrogen bonding and make the bulk layer of water; which becomes a part of the stationary phase, the principal factor in controlling the

retention. Both ion exchange and electrostatics are weak compared to other HILIC phases and the main influence of retention is partitioning between the mobile phase and the adsorbed water layer for the ZIC-HILIC column. For an overview of different HILIC stationary phases and applications, see Hemström and Irgum [46] and also Jandera [47]. The use of a zwitterionic (ZIC)-HILIC column as the first dimension in multidimensional separation of proteins has shown promising results as an alternative to the more conventional methods [48]. Combination of HILIC and RP has shown to give a higher orthogonality and peak capacity compared with alternatives like SCX-RP and size exclusion chromatography (SEC)-RP [49]. Combination of high pH RP in the first dimension and low pH RP in the second dimension has also shown to give a relatively high orthogonality, but is limited by only affecting the retention time of peptides with basic or acidic groups [50].

Ionization and MS detection of peptides

An important feature of using MS detection is the ability to identify proteins. A requirement for peptide detection in a mass spectrometer is that the molecule is ionized before entering the mass analyzer. Several combinations of ionization techniques and MS type have been applied in proteomics, but the most prominent techniques are matrix-assisted laser desorption ionization-time of flight mass spectrometry (MALDI-TOF-MS) and ESI-MS/MS. MALDI-TOF-MS was not used for this work and will thus not be described further.

The most common ESI configuration is on-line coupling of the liquid flow from the LC system directly into the ESI interface. In the interface, the liquid phase is pumped through a capillary where high voltage is applied resulting in formation of charged droplets pushed into a heating chamber. In the presence of nebulizer gas (nitrogen) the droplets go through several divisions while moving through the electrical field. This process repeats itself until the solvent is completely evaporated and only charged molecules are left, which then enter the mass analyzer. When using ESI, several charge states are possible (in contrast to MALDI). Nanospray is a low flow ESI, used at flow rates in the range of nanoliters per minute. The process is essentially the same as with regular ESI but because of the low flow rate, droplet formation occurs more readily requiring only applied voltage to generate spray. This means that no additional gas or heat is needed in the interface, improving both the stability of the spray and hence the signal. In addition, the ionization

efficiency is improved at such low flow rates due to less volume of mobile phase passing through the spray tip, producing smaller droplets.

ESI can be coupled to several types of mass spectrometers often chosen based on application and information needed. Different types of mass analyzers were used in this work including ion trap, TOF, single quadrupole and linear ion trap-Orbitrap (LTQ-Orbitrap). Geometry and principle of mass separation is different in each type of mass analyzer resulting in different properties such as mass resolution, mass range and ability to perform MSⁿ. The latter is an important feature in order to gain structure information by fragmentation of the molecules. Several techniques are used to cause fragmentation, but collision induced dissociation (CID) is still the most prominent. CID causes backbone cleavage on the peptides following collision with Helium gas; yielding fragments which can reveal the amino acid sequence (see Figure 4). The most common fragments are y and b ions, where the y ions extend from the C-terminal while b ions extend from the N-terminal. Analysis and interpretation of these ions (in addition to several other ions produced by fragmentation) are then used to elucidate the amino acid sequence of the peptide.

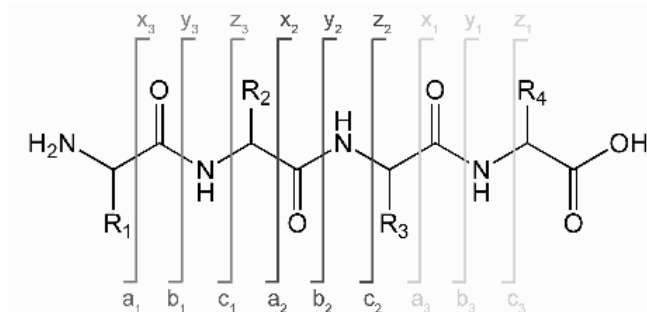

Figure 4. The most common cleavage sites following CID fragmentation. (This file is licensed under the Creative Commons Attribution-Share Alike 3.0 Unported license)

The Orbitrap mass analyzer

Several different types of mass analyzers were used in this work; most of them are established and have been used routinely for years. The Orbitrap (used in *Paper IV* and *V*), however, is a relatively new mass analyzer which already has made a large impact in the proteomics field; a short presentation of this mass analyzer will be given in the following

section. In 2000, Makarov described a new type of mass analyzer called the Orbitrap [51]. A model of this mass analyzer is shown in Figure 5.

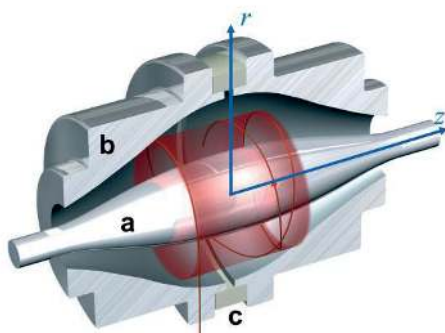

Figure 5. A model of the orbitrap mass analyzer (from reference [52] with permission)

The Orbitrap is actually an ion trap that uses orbital trapping of moving ions in an electrostatic field, but without the use of magnet or dynamic (RF) electrical field like a more conventional ion trap [53]. This technique offers high resolving power (up to 150000) and mass accuracy; mass deviations of sub-ppm has been reported in proteomics experiment [54]. Recently this was combined with a linear ion trap combining the mass spectrometric features of the ion trap with the high resolution and mass accuracy of the Orbitrap which resulted in the hybrid instrument named LTQ Orbitrap. This instrument consists of 3 main parts which are shown in Figure 6; the linear ion trap, a C-trap and the Orbitrap.

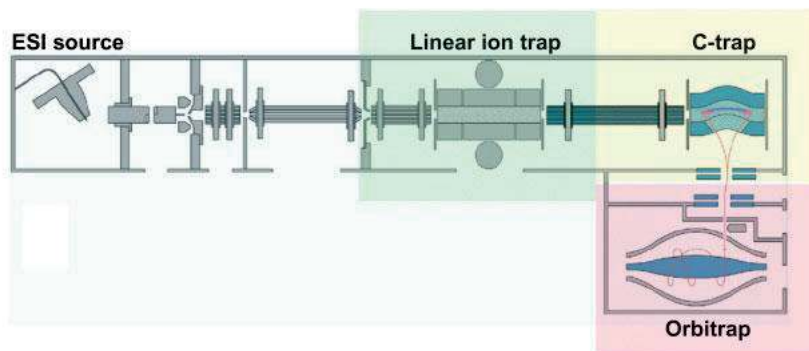

Figure 6. Schematic outline of the main components of the LTQ Orbitrap (from reference [52] with permission)

The linear ion trap (the first part) is capable of detecting MS and MSⁿ spectra at high speed and sensitivity but with low resolution and mass accuracy. Ions accumulated can then be transferred to the C-trap where they are accumulated and stored before sent into the Orbitrap in a pulse. The two mass analyzers can be used either separately or in combination depending on requirement of the analysis. In a typical proteomics experiment of an unknown sample both analyzers are normally used. The mass accuracy of the Orbitrap is used to obtain a very accurate mass of the precursor molecule, restraining the list of peptide candidates to a few sequences only. In parallel operation, the linear ion trap is used for fragmentation of wanted precursor molecules. This can theoretically also be done in the Orbitrap, but the linear ion trap is much faster and can deliver 3-5 spectra per second. The MS/MS spectra are usually detected in the linear ion trap but can also be sent to the Orbitrap for a more accurate mass detection. The high mass accuracy used for precursor detection is a clear advantage in peptide identification and largely decreases the problem with false positive peptide identifications which can be challenging when using low resolution mass spectrometers [55,56].

1.2.4 Quantification in urinary proteomics

To improve the ability to accurately monitor changes in the protein expression both relative quantification and absolute quantification methodologies have been developed for use in proteomics [57-61]. Quantification in urine can be a challenge due to large day-to-day variation in concentrations of proteins and peptides mostly related to varying fluid

intake [62]. Consequently, normalization of the proteome data is usually necessary. There are several approaches but none is perfect, although the use of normalization against total protein content is predominant in urinary proteomic studies [63].

Regarding relative quantification, most techniques are based on incorporating a stable isotope tag which results in a mass shift and enables comparison with an unlabeled sample [64]. One of the advantages of employing a relative quantification approach is the reduction of experimental variability. Hence, an early introduction of the labeling step in the proteomic workflow is beneficial to decrease the variability as much as possible.

Several strategies for stable isotope labeling are available including isotope-coded affinity tags (ICAT) [58], isobaric tag for relative and absolute quantification (iTRAQ) [59], tandem mass tags (TMT) [60] and ^{18}O -labeling [61,65]. In this work, ^{18}O -labeling was the method of choice. Some of the advantages with this approach are that all proteolytically generated peptides are labeled (except C-terminal peptides) and at low costs compared with e.g. iTRAQ. One major disadvantage is that the procedure is relatively time-consuming and labor-intensive to achieve complete labeling. [66] ^{18}O -labeling is performed enzymatically mostly using trypsin, but enzymes like Lys-C and Glu-C are also used [66,67]. Labeling is performed at peptide level, and an incorporation of two ^{18}O atoms results in a mass shift of +4 Da for the labeled peptides.

Incorporation of the ^{18}O atoms by trypsin can be done in 2 different chemical reactions as shown in Figure 7 [68]. If H_2^{18}O is present during tryptic digestion (amide bond cleavage), one ^{18}O atom will be incorporated in each peptide. For the next ^{18}O to be incorporated, a carboxyl oxygen exchange reaction must take place. This reaction is an equilibrium and hence required to occur multiple times to push the equilibrium towards two ^{18}O atom incorporated and achieve complete labeling. When ^{18}O -labeling is done separately from tryptic digestion, both ^{18}O atoms are exchanged by the carboxyl oxygen exchange reaction.

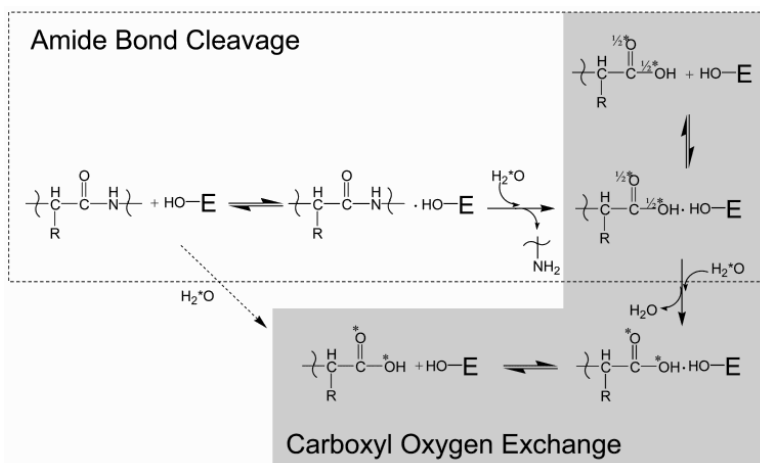

Figure 7. Illustration of ^{18}O -incorporation by two different mechanisms, amide bond cleavage and carboxyl oxygen exchange (From reference [68] with permission).

Incorporation of both ^{18}O atoms into the peptides is a very time consuming process [64,69], since it needs to be complete for reliable quantification. Several suggestions have been made to accelerate this process (ultrasound etc.) [70], but none has resulted in large improvement of the reaction time [66]. The carboxyl oxygen exchange reaction has fairly recently been reported to be pH dependent and far from ideal in the pH range of tryptic digestion, which has been the basis for many labeling protocols [69]. This has led to recommendations of optimizing tryptic digestion and labeling conditions separately and rather use a decoupled procedure [66,69].

Another challenge with ^{18}O -labeling is back exchange to ^{16}O when labeled samples are mixed with unlabeled samples before LC-MS analysis, a reaction which is likely as long as trypsin is present [71]. To reduce this effect, immobilized trypsin on solid supports can be used for labeling since the trypsin can be separated from the solution stopping the labeling reaction. Sevinsky et al. also applied immobilized trypsin for protein digestion prior to labeling, in order to reduce the risk of back exchange further [72]. Despite these efforts to improve labeling, the reaction time remains a bottleneck in many $^{18}\text{O}/^{16}\text{O}$ -labeling lasting up to 48 hours [72-74]. Accurate quantification can only be obtained with complete labeling.

1.2.5 Data acquisition

Protein identification by mass spectrometry can be done either by Peptide Mass Fingerprinting (PMF) or by the use of tandem MS, both based on data from enzymatically digested proteins. Figure 8 shows a schematic workflow of the process when tandem-MS data are used for identification. The workflow is similar for PMF, but protein identification is carried out without MS/MS data and by only comparing detected masses with theoretical peptide masses obtained by *in-silico* digests of an entire protein database [75-79]. The general approach is similar in both cases. Experimental data are compared with calculated theoretically mass values obtained by applying appropriate enzyme information to entries in a database containing protein sequences (see later for different databases). Corresponding mass values are then scored in a way that allows for identification of the peptides and the proteins that best matches the peptide composition in the sample.

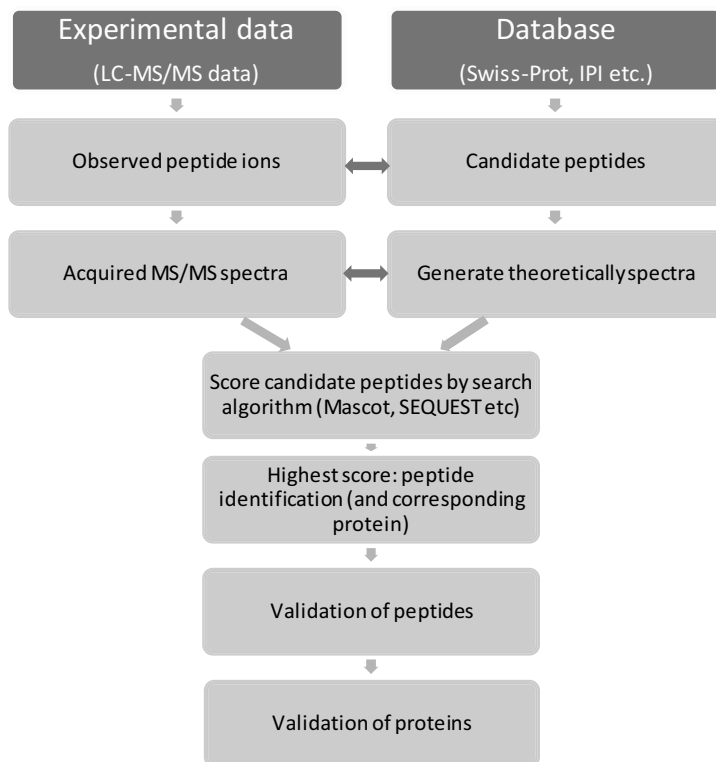

Figure 8. Schematic workflow for peptide/protein identification after LC-MS/MS

Several search engines with different scoring systems are used for this purpose and Mascot [80] and SEQUEST™ [81] are some of the most frequently applied. In the case of PMF, a fingerprint of molecular weights measured is used to match the theoretically peptides generated from proteins in the database of choice. A large number of identified peptides corresponding to a certain protein is a good fingerprint which yields a high score and hence a more confident identification. The use of PMF gives no sequence information for each peptide and is best suited for identification in relatively simple protein samples.

In complex protein samples, more sequence information is required to achieve unambiguous identification of peptides and hence proteins. This is achieved by tandem MS [82], where specific fragment ions are used to determine the amino acid sequence of the peptides (see section 1.2.3. for peptide fragmentation). In the process shown in Figure 8, the observed peptide ions are compared with theoretically peptides possible from the database based on similarity of molecular weight. This search is done within a certain mass tolerance window which is relative small for high accuracy instruments (e.g. Orbitrap) and large for low accuracy instruments (e.g. ion trap). In practice this means that the list of candidate peptides will be much smaller and more defined for high accuracy data. Further, the experimental MS/MS data from each peptide mass observed is compared with theoretically spectra from the database. The search algorithms then gives each candidate peptide a score based on how many fragment ions that are matched with the theoretical spectra. This scoring system is relatively complex and involves different parameters depending on the algorithm used. The peptide with the highest score is assigned as a positive identification. All hits are usually validated to decide if the identification is false or true, typically including search against reverse databases and score thresholds. The resulting peptide list is then linked to the corresponding proteins for protein identification. A long list of peptide with high identification scores linking to a certain protein will typically generate a high protein score. In this thesis, the Mascot search engine was used in *Paper I* and *III* while SEQUEST was used in *Paper IV* and *V*.

Proteome Discoverer, used in *Paper IV* and *V*, is a protein identification software platform for use with all mass spectrometers from Thermo Scientific (and some others). The platform works with both Mascot and SEQUEST™ search engines and supports several types of quantification methods (e.g. ¹⁸O labeling) where data can be obtained directly from .raw-files or other common spectrum data formats. There are several protein sequence databases, greatly varying in size and quality, available from different

consortiums to choose from for use in proteins searches. An example of this is the UniProt knowledgebase (UniProtKB) which consist of two sections. UniProtKB/Swiss-Prot contains only reviewed, manually annotated entries (525997, 8-Mar-11). The database is highly annotated including detailed information regarding protein structure, functions etc. and is updated at a regular basis. UniProtKB/TrEMBL is also based on high quality data, but is computer annotated and a supplement to Swiss-Prot containing all the translations from EMBL not yet integrated into Swiss-Prot (13897064 entries, 8-Mar-11). Other popular databases include NCBItr (largest and most frequently updated) and IPI, which contains single species databases from whose genome has been sequenced (includes combined protein entries from UniProtKB in addition to predicted protein sequences from Ensembl and RefSeq).

2 Aim of the study

The current gold standard for diagnosis of suspected acute rejection episodes in kidney transplants is done by histological examination of renal core biopsies. This is primarily done to verify a suspicion of acute rejection based on a sudden increase in plasma creatinine that cannot be explained by other causes. The use of plasma creatinine as an AR biomarker is flawed by both its low specificity and the relatively late reaction time. This necessitates both the use of biopsies for verification and the use of powerful anti rejection therapy, which is associated with adverse events per se. If an earlier and more specific biomarker of AR episodes was available it may be that a minor adjustment of the immunosuppressive therapy would be enough to silence the early activated immune process. The clinical implications of this could be better long-term outcome for renal transplant recipients. Analysis of urine is particularly useful as biomarker matrix since it contains both proteins originating from plasma as well as locally in the kidney. Another important advantage is the non-invasive sampling as opposed to biopsies.

To be able to analyze the urinary proteome, a method had to be developed and the specific aims were as follows:

- Develop a sample preparation with high protein recovery and effective desalting.
- Investigate different formats and technical solutions for tryptic digestion of proteins.
- Develop a multidimensional chromatographic separation strategy.
- Optimize and implement a relative quantification strategy based on stable isotope incorporation ($^{18}\text{O}/^{16}\text{O}$ -labeling).
- Optimize and streamline the complete procedure to achieve a high degree of downstream compatibility.
- Downscale analysis to nanoscale separation (nanoLC-MS/MS) to increase sensitivity.
- Investigate the variability of the method.
- Investigate on-line alternatives.
- Analyze urine samples from kidney transplants experiencing acute rejections to identify associated proteins.

3 Results and discussion

The methodology in bottom-up proteomics is complex, time demanding, labor intensive and there are several possible pitfalls. In this thesis the focus has been on developing a urinary proteomics method to be able to find differentially expressed proteins associated with acute rejection episodes in kidney transplants. The first three papers have been focused around the sample preparation, tryptic digestion and the chromatographic separation. First of all, the workflow was optimized and streamlined to reduce the variability and maximize proteome information (*Paper I*) followed by investigation of different approaches for tryptic digestion (*Paper II and III*). In *Paper IV*, a quantification method was modified and implemented in the workflow before the complete method was utilized in the patient study (*Paper V*). The idea was to provide a solid analytical fundament in order to be confident that possible differential expressed proteins associated with acute rejection episodes were based on pathological changes and not poor repeatability of the method. In addition, much effort has been put on developing a more time efficient methodology than current standard protocols.

3.1 Sample preparation and separation in urinary proteomics

A bottom-up proteomics experiment is a complex multi-step procedure typically including sample preparation, depletion and multidimensional separation followed by MS-detection. Each step in the procedure is a possible source of variability and/or protein loss. In addition, the chemicals used in each step are not always compatible with the next step making extra sample handling necessary. Simplification and streamlining was one of the main principles laid to ground in the method development in order to decrease variability and increase repeatability and time efficiency. In addition, other parameters like protein recovery and separation selectivity of the chromatography was assessed to maximize the information obtained from the urinary proteome. Figure 9 shows the workflow and the solvents used in each step to demonstrate the downstream compatibility achieved as specified in the next chapters.

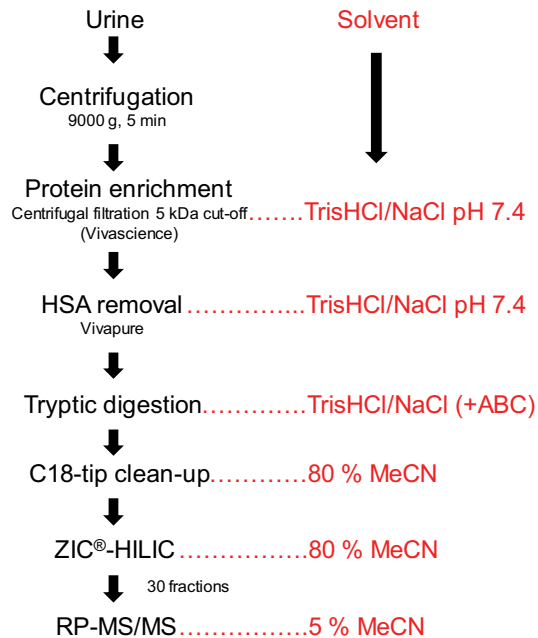

Figure 9. Schematic outline of the main steps of the method workflow and solvents used in the respective steps.

3.1.1 Sample collection and storage

For the study in *Paper V*, urine was collected as part of an at that time ongoing study at Oslo University Hospital (n=20) [83]. All patients were followed prospectively during the early post transplant phase after transfer from the surgical department: Urinary samples were collected three times weekly the first two weeks, twice weekly the next four weeks followed by 1-2 samples per week until approximately 10 weeks after transplantation. Patient samples used in *Paper I* and *IV* was collected from anonymous kidney transplant patients in a stable phase post-transplant. Other urine samples used were from healthy individuals. All samples were collected as follows: Midstream urine were collected, left at 4 °C for up to one hour, centrifuged at $800 \times g$ for 10 minutes and stored at -70 °C.

3.1.2 Sample preparation

Choice of method

For a successful urinary proteome analysis, isolation and purification of the proteins is necessary. In *Paper I*, several sample preparation approaches were tested. Criteria for

evaluation were high protein recovery, possibilities for enrichment and effective desalting of the sample. Table 1 (unpublished data) shows protein recoveries from commonly used protein enrichment methods like ethanol precipitation, centrifugal filtration and TCA precipitation followed by reconstitution in either 25 mM TrisHCl or 8 M Urea.

Table 1. Protein recoveries from urine using various sample preparation methods^a

Enrichment method	Resuspension	
	25 mM TrisHCl	8 M Urea
Ethanol	55 %	71 %
Centrifugal filtration (5 kDa cut-off)	58 %	92 %
10 % TCA (1:5)	<20 % ^b	<20 % ^b

^a The recoveries were obtained adding 1200 μ L TrisHCl or urea followed by 30 minutes on a rotary shaker at 600 rpm.

^b The values were below the arbitrary limit of 20 %.

Both ethanol precipitation and centrifugal filtration provided acceptable protein recoveries from urine in the range of 55 – 92 %. Precipitation using 10 % TCA had no effect in urine and only low protein recoveries (<20 %) were obtained. Since centrifugal filtration provided the best recovery in addition to low variability (RSD of 10 %, n = 4) it was chosen as the preferred sample preparation method in the further development of the strategy. The use of centrifugal filtration was also shown to be an effective desalting step, which is important for the further analysis of urine.

Optimization

In order to improve the recovery and thus covering a larger part of the proteome, different solutions with increasing volumes (600 μ L – 2400 μ L) were added to the remaining volume over the 5 kDa-filter of the device. Figure 10 shows that for all solvents tested the recovery increased with increasing volumes up to approximately 1800 μ L. The highest recovery was obtained using 8 M urea, but this was considered to be unsuitable due to the downstream incompatibility with HSA depletion and the requirement of an extra step to remove excess urea. High recoveries were achieved with 10 mM TrisHCl/150 mM NaCl

(pH 7.4), and more important, this solution was downstream compatible with the HSA depletion step that made it a better choice than urea.

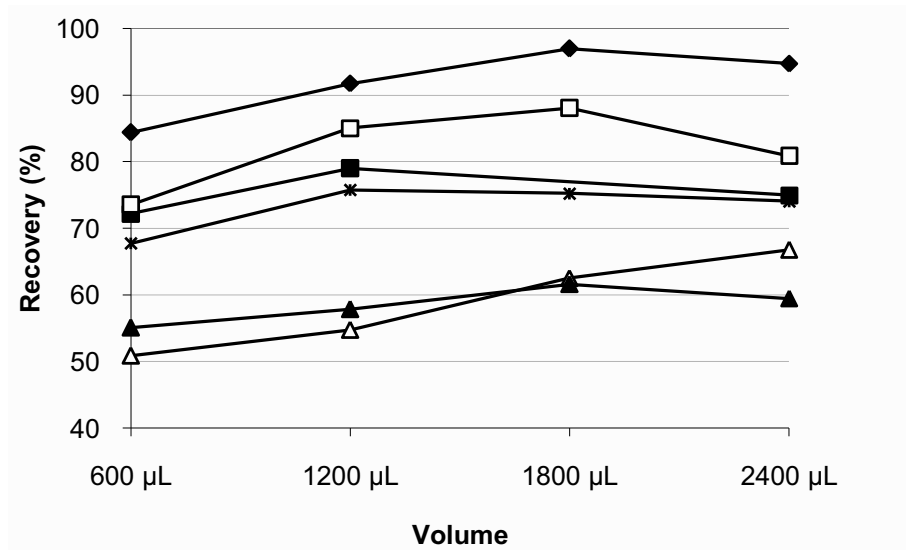

Figure 10. Protein recovery from centrifugal filters (5 kDa cut-off) using different volumes of water (×), 25 mM TrisHCl (▲), 25 mM TrisHCl + wash (Δ), 8 M Urea (◆), 10 mM TrisHCl/150 mM NaCl (■), 10 mM TrisHCl/150 mM NaCl + wash (◻) to redissolve the proteins after centrifugation

HSA depletion

In contrast to plasma, the concentration of the various proteins in urine seems to be more evenly distributed. Hence, the dynamic range is reduced and depletion of only HSA has been reported to be sufficient to be able to identify low abundant proteins in urine [28]. A combination of this and the risk of information loss after depletion (see chapter 1.2.1) lead to the choice of depleting only HSA. Gel electrophoresis of the samples (Figure 11, unpublished) showed efficient removal of HSA from urine using this kit. With only a minor pH adjustment, trypsin could be added directly to the depleted sample for protein digestion.

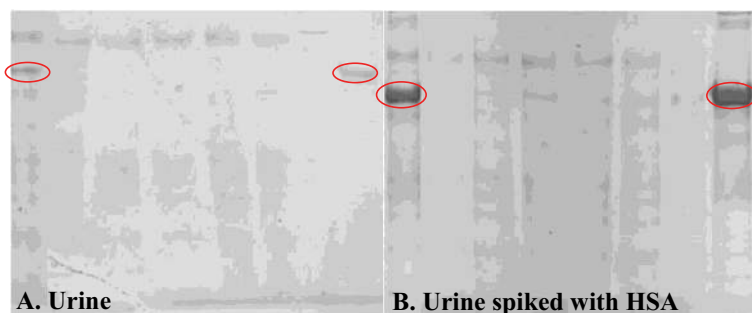

Figure 11. Gel electrophoresis of 2 urine samples depleted for HSA (red marking). Gel A was pure urine, gel B was spiked with HSA. Lane 1 in the gels shows crude urine prior to depletion. Lane 2-6 shows the flow-through fractions with depleted urine and lane 7 is a washing step. Lane 8 shows the fractions where trapped HSA from the samples is eluted.

3.1.3 Chromatographic separation of the peptides

A proteolytically digested protein sample usually yields highly complex peptide mixtures where the separation power offered by standard RP columns is far from sufficient to obtain quality data from the MS analysis. In order to improve this, the introduction of multiple chromatographic separations is often done to achieve a higher separation power and increased amount of information obtained. In *Paper III*, separation already at the protein level was investigated to decrease the sample complexity prior to tryptic digestion. The native proteins were separated by pH gradient strong anion exchange (SAX) chromatography. This was a component of an on-line multidimensional separation system that has partly been described previously [84]. In the earlier described system, the protein recoveries from the trap columns employed (C4 + C4) were relatively low. This was however greatly improved in this work by using a more acidic mobile phase (0.1 % formic acid) compared to the original mobile phase (0.1 % NH₄OAc, pH 7.5). The protein recoveries were improved from 42 % to 76 % and 0.1 % formic acid was thus chosen for the further work.

Advantages with this system was that valuable information from the native proteins, like e.g. pI, was obtained and the use of on-line coupling is potentially less prone to sample loss and contamination. It was however decided that the separation capability would be more advantageous using an approach with multidimensional peptide separation and protein separation on top of this would be too comprehensive and labor-intensive for each sample. Protein separation was thus not included in the final method used for the

patient study (*Paper V*). As described in section 1.2.3, the combination ZIC-HILIC-RP has shown promising results as separation system in proteomic analysis due to the high orthogonality of the two column types. The combination was investigated in *Paper I* and, based on the performance, made the preferred separation system for the further work (*Paper IV* and *V*).

First-dimension separation: ZIC-HILIC

In the development phase both 80 % MeCN and 95 % MeCN were investigated as starting conditions for the gradient elution and also sample solvent for the respective setups. Chromatograms separating a *cyt c* digest in both gradients are displayed in Figure 12, which shows a significant difference not only in peak height of the peptides, but also in total number of peaks detectable.

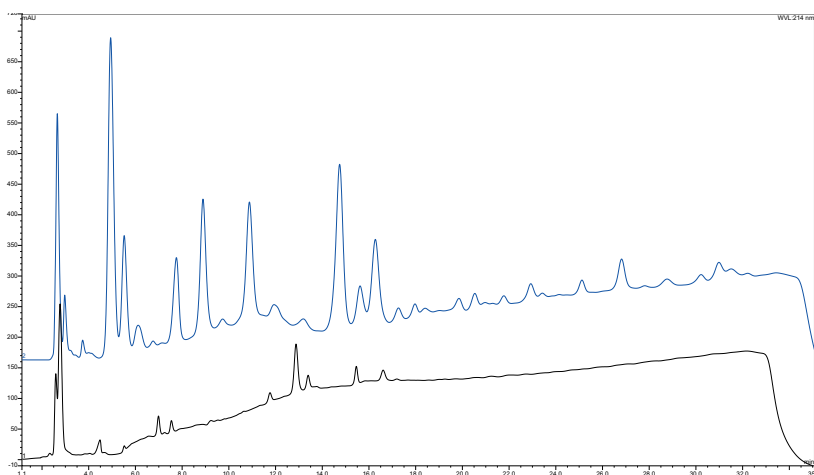

Figure 12. The upper chromatogram shows gradient elution separation of a tryptic digest of *cyt c* on a HILIC column starting at 80 % MeCN. The lower chromatogram shows separation with 95 % MeCN as gradient starting conditions. Both samples were dissolved in its respective starting mobile phase and equal concentrations of *cyt c* were used.

This may be due to decreased solubility of the peptides in the 95 % MeCN mobile phase, which particularly affects the hydrophilic peptides. As a consequence only the most hydrophobic peptides may be solubilized resulting in lower peak heights and fewer peaks.

Hence, it was decided that 80 % MeCN was used as gradient starting mobile phase and as sample solvent.

Second-dimension separation: Reversed Phase

Reversed phase (RP) chromatography was used as the separation technique in the second dimension when multidimensional separation was applied. This was due to the ideal combination when coupled to HILIC as pointed out in the previous section. Additionally, RP separation was carried out as only dimension when used as analytical tool in the development work. Initially, microscale columns (1 mm ID) were used for separation but downscaling was necessary particularly to increase the sensitivity for the analysis of the patient samples. In *Paper I*, capillary columns (0.32 mm ID) were used in combination with short trap columns of larger diameter (1 mm ID), enabling large injection volumes (50 μ L), to increase the sensitivity. As described later, in section 3.2.5, this increased the number of identified peptides/proteins substantially.

Further downscaling was done in *Paper V*, utilizing nano separation (75 μ m ID columns) in combination with nanospray ionization and trap columns (0.32 mm ID) that enabled the same injection volumes as in *Paper IV*. As expected from chromatography theory, the sensitivity of this approach was superior to the configurations using larger columns and a large number of peptides and proteins were identified with a high degree of confidence. This is effectively demonstrated in Figure 13 where corresponding fractions from two different experiments distinguished by the use of hence nano- and microscale columns are presented. The scales on both y-axes have been normalized against total protein concentration in the respective samples and are hence directly comparable. In the chromatogram where a micro column is used, few peaks are possible to separate from the baseline noise of the chromatogram. The other chromatogram, utilizing nano separation, is highly complex showing a large number of peaks. While the use of low flow chromatography offers superior sensitivity, there are several pitfalls and challenges by using such a system compared with normal flow. One of the challenges is that even small compartments of dead volume can have a large impact on the chromatography in a nano system while it would not even have affected a normal flow system. This makes the use of correct tubing and couplings of outmost importance to minimize these effects. Furthermore are mounting of columns and changing of other parts of the flow-line critical operations

where small details like for example an inadequate tightened coupling can lead to large changes of the chromatography. Identification of such problems could also be challenging since leakages are hard to discover due to the low flow in the system.

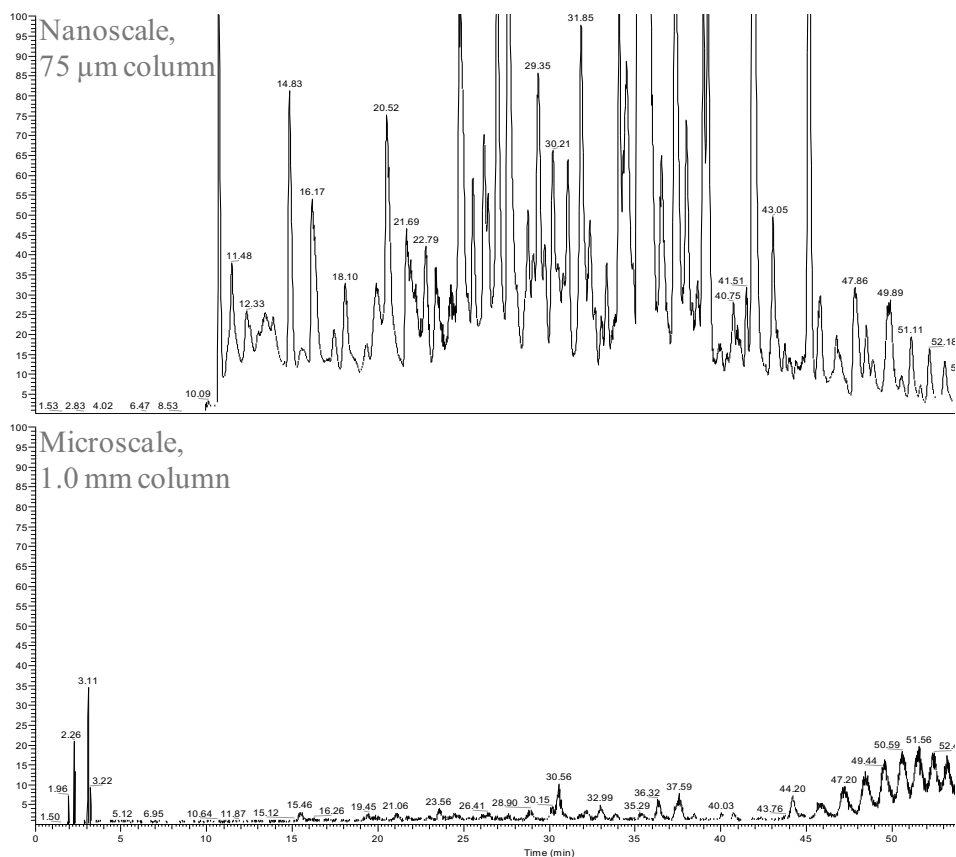

Figure 13. Chromatograms of corresponding fractions analyzed in the second dimension from two similar experiments distinguished by the use of nano and micro columns respectively. The samples contained comparable amounts of total protein.

Finally, the combination of the HILIC and RP was tested to gain information on the peak distribution and orthogonality with the chosen conditions. A tryptic digested urine sample from a renal transplant recipient was used to demonstrate the orthogonality of the system. The fraction number from the ZIC-HILIC separation was plotted against the retention time of the peaks in the 2nd dimension (RP) shown in Figure 14.

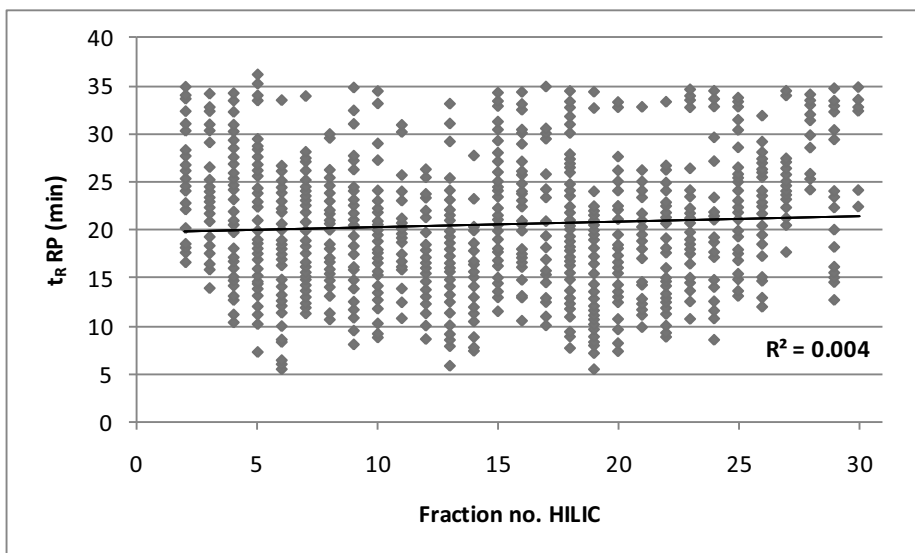

Figure 14. Plot of retention time (t_R) of peaks in the 2nd dimension (RP) vs. fraction number from the 1st dimension (HILIC). The sample used was from a kidney transplanted patient

The plot shows a rather even distribution of peaks throughout all fractions and gives a good overview of the peak distribution and the difference in selectivity between the two dimensions. Another observation is that the distribution on the second axis (retention time 2nd dimension) is comparable in all fractions suggesting that the system is quite orthogonal, something which is also supported by the regression factor ($R^2 = 0.004$) indicating little or no linear correlation between the two dimensions.

3.1.4 Variability of the method: step by step evaluation of the workflow

The many steps that make up a complete proteomic experiment are all possible sources of variability. Various precautions can be taken to reduce this to a minimum, where the ultimate aim is no methodological variability at all. This is however unrealistic and identification of the method related contribution to variability is hence useful for quantification purposes. In order to evaluate the variability of the current method, 6 replicates of a pooled urine sample from 3 renal transplant recipients were analyzed. These

were true replicates prepared separately through the whole workflow. Relevant parameters from each step were evaluated, summarized in Table 2.

Table 2. Overview of key variables and variability in different steps of the workflow

Workflow step	Variable	Value	RSD (%) ^a
Sample preparation	Protein recovery	5.6 mg/mL	9.2
HSA depletion	Protein recovery	1.7 mg/mL	6.7
1 st dimension LC (HILIC)	Retention time	5.8 – 27.4 min	0.35 ^b
2 nd dimension (RP-MS/MS)	Peak intensity	4e ⁵ – 7e ⁶ units	28 ^c

^a n=6 for all steps, pooled urine from kidney transplanted patients.

^b average of 8 peaks in the retention window specified

^c average of 30 peaks from 3 fractions

Protein recovery was the measured variable after both sample preparation and HSA depletion. This functions as a rough parameter of the total proteome isolated and RSD values of 9.2 % and 6.7 % were calculated for the respective steps. In the first dimension of the two-dimensional separation, the variability of the retention time ranged from 0.15 % - 0.82 %. Large variability of the retention time in the first separation dimension is unfavorable since it will have a large impact on the composition of the fractions analyzed in the second dimension. The last variable was peak intensity in the second dimension. Intraday RSD varied between 11 % and 30 % depending on the fraction. Besides variations in the last step itself, the peak intensity also reflects total variations through every step in the method. Both variations in protein recovery and retention times in the first dimension affect the signal variability in the last step in addition to sources directly related to that step (e.g. electrospray ionization).

3.2 Tryptic digestion & protein identification

3.2.1 Optimization of digestion conditions using immobilized trypsin beads

Tryptic digestion of proteins has traditionally been carried out *in-solution* [85,86], which also was the case in *Paper I*. The procedure is well established but suffers from long reaction time and is typically done overnight. As a strategy to reduce the total time frame of the workflow, enzymatic digestion using immobilized trypsin was tested as a replacement for *in-solution* digestion (*Paper II*). The digestion time is described to be

strongly reduced because of the high effective protease concentration on the solid support compared to *in-solution* digestion. Different digestion reactors were investigated (see Figure 15) using BSA as a model substrate for the optimization of the digestion.

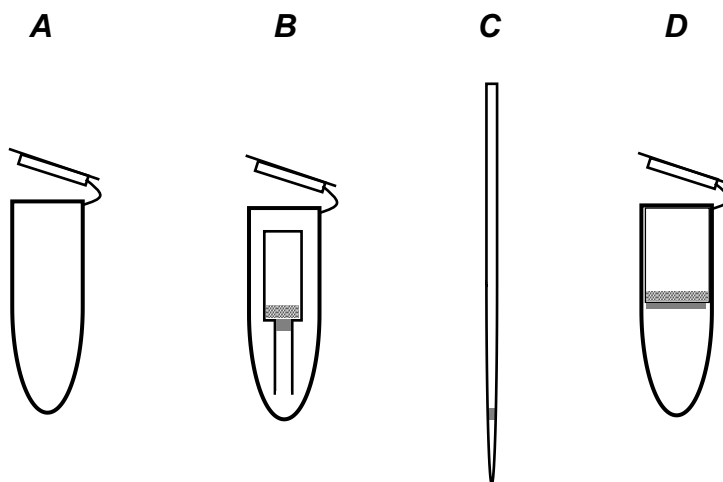

Figure 15. Different digestion reactors (A-D) which were investigated

Reactor D showed the best digestion efficiency and offered the possibility for effective wash-out of proteins/peptides from the beads promoting possible re-use. This format was thus chosen for the further optimization experiments. The optimal condition for BSA digestion was found to be a reaction time of 89 minutes at 37 °C using 800 rpm agitation. For the development of quantification method (*Paper IV*) and hence the optimized method used in chapter 3.4 (*Paper V*), reactor A was used instead of reactor D. Reactor A yielded almost equal digestion efficiency and the risk of sample loss was considered lower than in reactor D, an essential aspect in the method development in *Paper IV*. Additionally, the beads were not intended for re-use which was an important benefit of reactor D.

3.2.2 In-solution digestion vs. digestion on immobilized trypsin beads

Even though proof of concept was demonstrated in the early results, showing extensive protein digestion within minutes, benchmarking against the established method was necessary. The optimized digestion procedure using immobilized trypsin beads (BSA in reactor D) was compared with digestion *in-solution* by parameters like visual comparison of the resulting chromatograms, peak intensity of digestion products, sequence coverage,

masses matched and amount of uncleaved peptides. The qualitative information obtained from the two methods was comparable looking at signal intensity and sequence coverage, but differences in digestion kinetics are likely based on the results. However, the slightly lower number of peptides with missed cleavages identified using immobilized trypsin indicates a better completeness of the digest. Including the substantial reduction of reaction time from overnight to 1.5 hours, the benefits of using immobilized trypsin are conspicuous.

3.2.3 Digestion efficiency in human urine

Following the promising results in buffered solutions, testing of the procedure in a more complex matrix was necessary to assess the usefulness in a biological experiment. This was done by performing BSA digestion in a complex urine sample using immobilized trypsin beads and comparing with an equivalent experiment in a buffered sample. Signal intensity of 12 peptide products were monitored and the urine sample was depleted for HSA to ensure that a minimum of HSA peptide products would interfere with the peptide products from BSA. The results are summarized in Table 3, where peak intensities obtained in aqueous buffer and urine are compared. Similar intensities were found for many peptides, however, both higher and lower intensities of several peptides were observed after digestion in urine compared to in buffered solution. This could be due to different reaction kinetics in urine, possibly related to foreign components. Another factor contributing to the differences detected, could be presence of co-eluting compounds suppressing ionization of certain peptides in the MS-analysis. Noteworthy, Table 3 also shows that repeatability is good for the tryptic digestion in urine. RSD values below 10 % for all peptides (except one), are well within the limits of acceptance for determination of compounds like drugs in biological matrices.

Table 3. Identified peptides of BSA in urine and buffer

m/z peptide	Specificity ^a Present in BSA/HSA?	Missed Cleavages	BSA digest in urine (n=3)		BSA digest in buffer (n=3)	
			signal intensity (x10 ³)	RSD (%)	signal intensity (x10 ³)	RSD (%)
395.3 LVTDLTK	BSA and HSA	0	122.7	4.7	202	0.9
417.2 FKDLGEEHFK	Only BSA	1	8.3	6.9	76	3.5
461.7 AEFVEVTK	Only BSA	0	71.7	3.5	191	6.0
435.9 HLVDEPQNLIK	Only BSA	0	39	5.1	24.3	11.9
547.3 KVPQVSTPTLVEVSR	BSA and HSA	1	51	11.8	89.7	8.1
582.3 LVNELTEFAK	Only BSA	0	104	6.7	80.7	25.1
507.8 QTALVELLK	Only BSA	0	118.7	2.9	130	15.0
818.4 ATEEQLK	Only BSA	0	5	^b	<5	^a
634 LGEYGFQNALIVRYTR	Only BSA	1	<5	^a	5.5	^b
815.7 DDSPDLPKLKPDNPTLCDEFK	Only BSA	2	9	^b	5	^b
589.8 HLVDEPQNLIKQNCDFEK	Only BSA	1	11.3	5.1	25.3	13.9

^a signals were observed but below the arbitrary limit of 5x10³.

^b one of the signals observed was below the arbitrary limit of 5x10³.

^c From BLAST analysis: <http://www.ncbi.nlm.nih.gov/blast/Blast.cgi>

3.2.4 On-column reduction, alkylation and tryptic digestion

In order to look for other alternatives regarding tryptic digestion, an approach using integrating tryptic digestion on-line with multidimensional separation was investigated (*Paper III*). One of the benefits with on-line systems is the possibility for automation that in turn could increase sample throughput. The system consisted of pH gradient SAX chromatography of native proteins in the first dimension which then were fractionated and stored on trap columns (C4-C4) for subsequent on-column reduction and alkylation. The alkylated proteins were then transferred to an analytical C4 column for separation followed by on-column tryptic digestion coupled to ESI-MS detection (see Figure 16 for flowchart). Four proteins (lysozyme, β -lactoglobulin A, myoglobin and HSA) containing varying amounts of cystein groups (site of alkylation) were used to evaluate the performance of the reduction/alkylation step. Overall, the results showed a very efficient alkylation of both proteins with few cystein groups (e.g. β -lactoglobulin A) but also of the cystein-rich protein HSA.

To investigate the digestion efficiency of the TPCK-trypsin column in the system, a mixture of 5 proteins was analyzed. The mixture was digested in two modes; continuous-flow and stop-flow (flow stopped for 30 minutes). The results were satisfying for the majority of the proteins yielding sequence coverage in the range of 65 – 75 % in the continuous mode and 74 – 90 % in stop-flow mode. The procedure was not optimal for β -lactoglobulin A, where several peaks from the intact protein were observed. Digestion of

the largest protein in the mixture (HSA) was neither optimal, yielding few tryptic peptides even in stop-flow mode. In general, stop-flow mode produced a larger number of peptides and better sequence coverage but increased the total analysis time of one sample with 4.5 hours (9 fractions). Despite the benefits of automation, this approach was not chosen for the final setup (*Paper V*). This was mainly due to varying digestion quality (need for further optimization), complex setup and difficulties including ^{18}O -labeling (*Paper IV*) in the procedure.

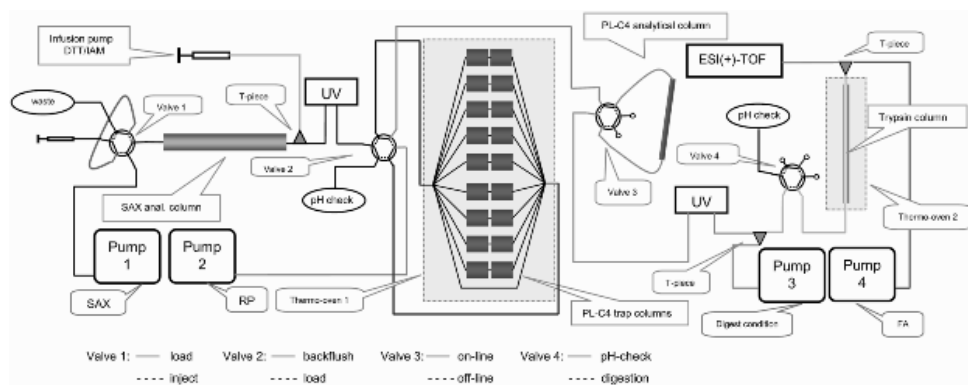

Figure 16. Scheme of the on-line coupled instrumentation system

3.2.5 Protein identification by different analytical platforms

In the method development, different LC-MS/(MS) equipment were utilized. The columns used ranged in size from micro (1 mm ID, *Paper II* and *IV*) to capillary (0.32 mm ID, *Paper I* and *III*) and nano (75 μm ID, *Paper V*). In addition, trap columns were used in the capillary and nano setup to increase the injection volume and hence sensitivity. Both low resolution MS equipment like ion traps (*Paper I* and *II*), and high-resolution MS instruments like TOF (*Paper III*) and LTQ-Orbitrap (*Paper IV* and *V*) was used for detection. The ion traps and LTQ-Orbitrap also provides MS/MS capabilities. Choice of equipment was partly based on availability but also according to certain specifications depending on use. In Table 4 the different platforms are compared with respect to number of peptides and proteins identified. The combination of miniaturized chromatography including trap columns and MS/MS identification resulted in a significant higher amount of identified proteins compared with the other platforms. Not surprisingly, the highest number of identified proteins was achieved using nanoscale chromatography coupled to

the LTQ-Orbitrap where up to 1022 proteins were identified in one single sample (the average was 670 proteins).

Table 4. *Different platforms used for peptide/protein identification*

Paper	LC	MS	ID	Peptides	Proteins
I	Cap.	Ion trap (Bruker Esquire 3000 ^{plus})	MS/MS	1668	438
III	Cap.	Time of Flight (LCT Micromass)	PMF	46	4
IV	Micro	LTQ-Orbitrap (Thermo)	MS/MS	88	56
V	Nano	LTQ-Orbitrap (Thermo)	MS/MS	2710	670

In addition to the many proteins identified, the amount of false positive identified peptides/proteins is probably lower than compared with results obtained using ion trap MS/MS. This is related to the high mass accuracy of the Orbitrap, which reduces the number of possible peptide hits from a certain m/z -value considerably. In *Paper V*, the identified proteins were also validated by searching against the reversed database in order to eliminate false positive identifications. This was not done in *Paper I*. Even though a complex peak profile was seen in the chromatographic separation in *Paper III*, few proteins were identified in the fractions analyzed. This is probably strongly correlated to the use of PMF, which has considerable limitations in complex protein samples. If MS/MS had been used for identification, the list of identified proteins would probably be larger. Another striking observation is the large difference in identified proteins when going from microscale (*Paper IV*) to nanoscale chromatography (*Paper V*), even though the sensitive LTQ-Orbitrap is used as MS-detection in both cases. This is closely related to the increased sensitivity as pointed out in section 3.1.3.2 and showed in Figure 13.

3.3 Accelerated quantification in urinary proteomics utilizing ¹⁸O-labeling

As described in section 1.2.4; ¹⁸O-labeling was chosen as the preferred quantification strategy for the current work. There was however a potential for, and need to optimize the weak points of the existing procedures. Focus of the experiments was not to study each reaction in detail but a more practical approach, optimizing a method best fit for the application. The first area of focus was to improve the rate of the labeling reaction in order to achieve complete labeling and within a reasonable time frame. Secondly, one of the

biggest challenges of ^{18}O -labeling has been back exchange of ^{16}O after labeling making the quantification result less reliable. Immobilized trypsin beads were used in effort to decrease this effect. Moreover, other precautions as for example addition of 8 M urea to stop the trypsin effect after labeling was implemented to avoid back exchange. Finally, the knowledge on shorter tryptic digestion using immobilized trypsin beads (*Paper II*) was used to establish a common platform for both digestion and labeling. The incentive was to get a more time- and work-efficient procedure. In every experiment, equal amounts of digested protein after ^{18}O - and ^{16}O -labeling were mixed. The $^{18}\text{O}/^{16}\text{O}$ -ratio should then, under ideal conditions, be 1:1.

3.3.1 pH dependency and reaction time optimization

As previously mentioned, the rate of the carboxyl oxygen exchange reaction can be greatly accelerated by optimizing pH for the labeling step independently from the conditions used for tryptic digestion [69]. The reported optimum labeling conditions were at pH 6 when trypsin was used. To investigate this further, an experiment assessing both pH and reaction time was carried out to identify the conditions where complete labeling could be achieved in the shortest possible time. The anticipated optimum of pH 6 was used as the starting point and different length of reaction time at this pH was investigated as presented in Figure 17.

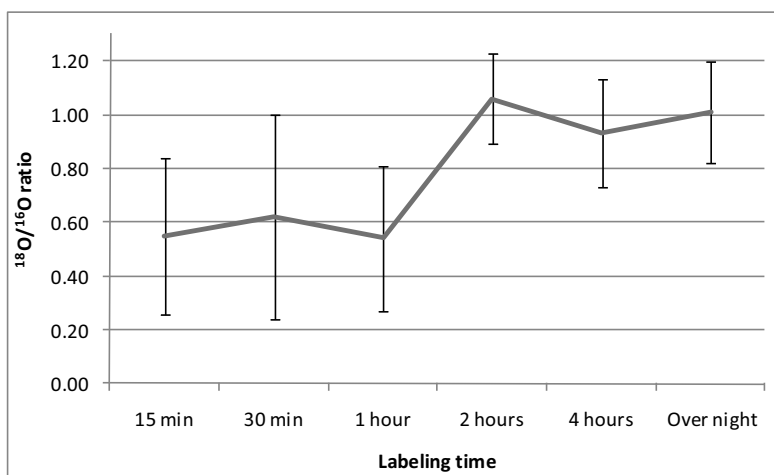

Figure 17. Average $^{18}\text{O}/^{16}\text{O}$ -ratios ($\pm\text{SD}$) of 12 BSA / cyt c peptides at different time points ($n = 3$). Labeling was done at pH 6

The results showed that extensive labeling was accomplished already after 15 minutes, but complete labeling was not achieved before 2 hours reaction time. Increasing the reaction length further produced the same $^{18}\text{O}/^{16}\text{O}$ -ratios and no reduction in variability was observed. In order to confirm the pH optimum reported by Hajkova et al. [69], the labeling reaction was carried out at different pH levels ranging from pH 5 to pH 9. The reaction time was set to 2 hours, which was shown to be sufficient for complete labeling at pH 6. The results presented in Figure 18 confirmed pH 6 as the optimum pH in the chosen pH range and also that the efficiency was rapidly declining moving up or down the pH scale.

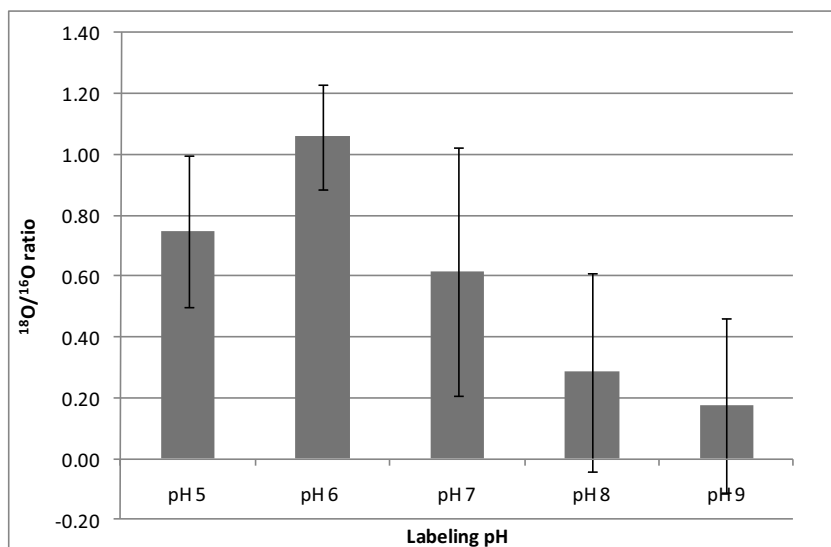

Figure 18. Average $^{18}\text{O}/^{16}\text{O}$ -ratios (\pm SD) of 12 BSA / cyt c peptides using labeling buffer of pH 5, 6, 7, 8 or 9 ($n = 3$). Reaction time was 2 hours for all samples

In both the pH and reaction time experiments, differences between lysine- and arginine-terminated peptides were observed. At pH 6 there was a clear tendency of faster labeling of peptides with arginine at the C-terminal, 3 out of 4 peptides monitored were actually completely labeled already after 15 minutes. This corresponds well with previously published work reporting problems with incorporating two oxygen atoms efficiently into lysine terminated peptides. [87]. The ratio of the lysine terminated peptides increased at a much slower rate than arginine terminated peptides. In addition the variability in efficiency between the lysine terminated peptides was large, obviously dependent on peptide

properties. The pH experiment also showed a tendency of different reaction kinetics between arginine and lysine terminated peptides. All of the peptides were completely labeled after 2 hours at pH 6. But while the lysine terminated peptides were poorly labeled at pH 7 (2 hours), the majority of the arginine terminated peptides were completely labeled at this pH as well. Arginine and lysine are quite similar amino acids but the pK_a -value of both the N-terminal and particularly the side chain is lower for lysine than for arginine. This could be a plausible explanation for the different labeling kinetics, suggesting that degree of protonation could play a role in the labeling process. Nevertheless, the optimum labeling conditions for all the peptides were at pH 6 which was used in the further work combined with a reaction time of 2 hours.

3.3.2 Integration of digestion and labeling using immobilized trypsin beads

The increased digestion efficiency observed after implementation of immobilized trypsin beads (section 3.2.1) combined with the fact that both the digestion and labeling steps were carried out using trypsin beads, lead to the idea of a closer integration of the two steps. The idea of tryptic digestion using immobilized trypsin prior to the labeling step has been described earlier, but not integrated in one sample reactor and done without optimized conditions in each step [72]. A more time efficient and less labor intensive procedure was the main motivation behind the idea of integration, encouraged by the experiments in section 3.2.1 and 3.3.1 proving the potential in optimizing the established procedures. Challenges like different reaction pH for the two reactions and introduction of $H_2^{18}O$ in appropriate amount to keep the cost at a reasonable level had to be solved. Figure 19 shows the complete optimized approach integrating tryptic digestion and ^{18}O -labeling in one procedure.

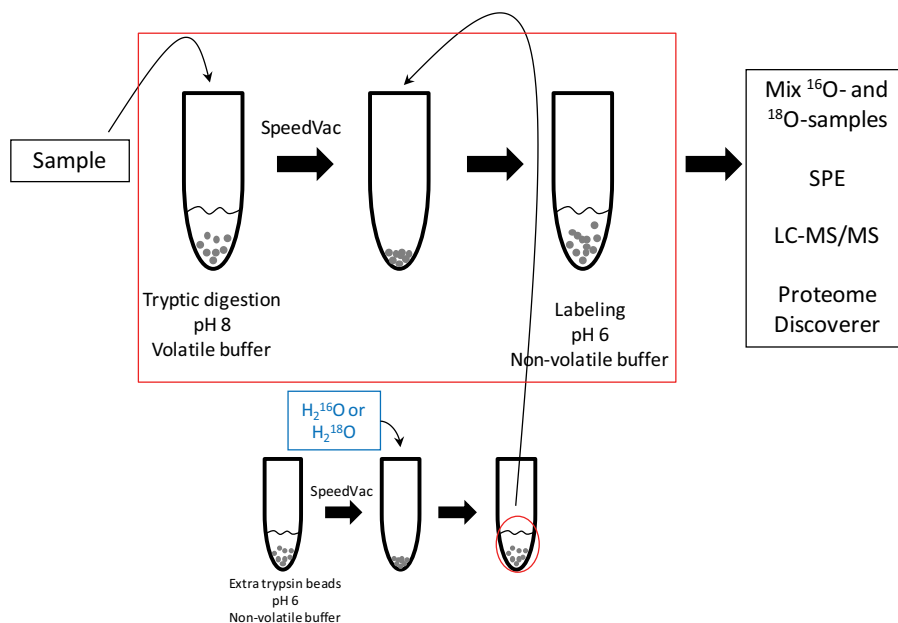

Figure 19. Overview of the integrated digestion and labeling procedure on immobilized trypsin beads. The sample is first digested in ammonium hydrogen carbonate buffer (in $H_2^{16}O$) followed by evaporation. The sample is then reconstituted in $H_2^{18}O$ containing buffer (pH 6) and extra trypsin beads (separate vial). Labeling is then carried out in the same vial as the digestion, and is stopped by removing trypsin beads and adding 8 M urea. Corresponding ^{16}O - and ^{18}O -labeled samples are mixed in a 1:1 ratio before LC-MS/MS analysis

The use of the volatile buffer ammonium hydrogen carbonate (pH 8) in the digestion step enabled buffer exchange by a simple evaporation step, followed by reconstitution in the labeling buffer (pH 6). In addition, the whole procedure was carried out without any transfer steps, greatly reducing possible sources of sample loss. The initial results yielded acceptable average ratios (Figure 20, result b), but the variation observed was noteworthy larger than compared with overnight in-solution digestion combined with labeling on immobilized trypsin (result a). The solution was to add an aliquot of fresh trypsin beads to the reaction vial between the digestion and labeling step, which reduced the standard deviation to a level below what was observed in the original setup.

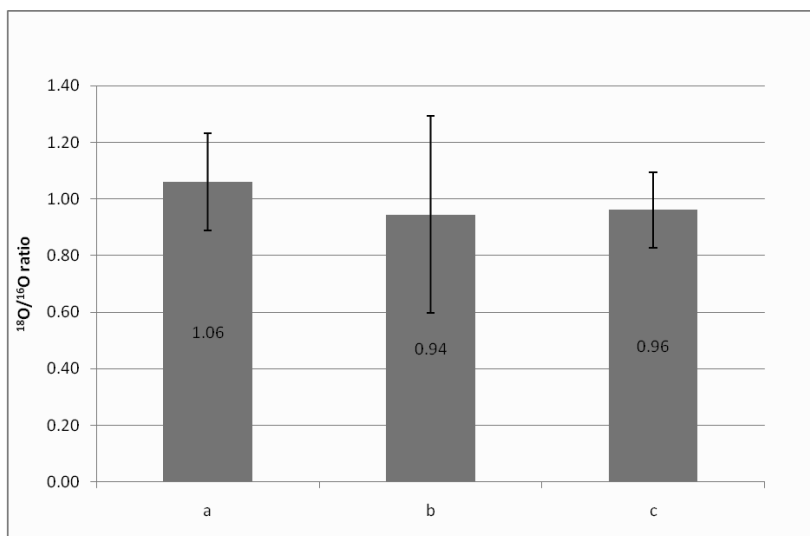

Figure 20. Average $^{18}\text{O}/^{16}\text{O}$ -ratios ($\pm\text{SD}$) for 12 BSA/cyt *c* peptides ($n = 3$). (a) Tryptic digestion in-solution/labeling on immobilized trypsin. (b) Both tryptic digestion and labeling on immobilized trypsin beads. (c) Both tryptic digestion and labeling on immobilized trypsin beads, extra beads added between the steps

Introduction of immobilized trypsin beads in the labeling and digestion steps introduces a risk of unspecific binding of peptides to the beads that could lead to lower recoveries. On the other hand the integrated approach has no sample transfer steps, an improvement that could prevent peptide loss compared to the original procedure. To evaluate how the replacement of *in-solution* digestion with the integrated approach using immobilized trypsin digestion affected the final peptide concentrations, peak intensities of selected peptide products from BSA and cyt *c* were compared for the different setups. The results are displayed in Table 5, showing the relative intensity change of the peptides going from in-solution to immobilized trypsin. All of the peptides evaluated, except LVTDLTK and LVNELTEFAK, increased in signal intensity when using immobilized trypsin beads. The peak intensity of some of the peptides increased dramatically, especially EDLIAYLK and EETLMLEYLENPK, which increased by 1704 % and 3794 % respectively. In conclusion, most of the peptides increased in peak intensity with the integrated approach, most likely because of the reduced need for sample transfer. All these results indicate that digestion and labeling can be performed in a satisfying manner using immobilized trypsin in both steps. An important aspect is the time-efficiency of this procedure, enabling reduction of

total reaction time of tryptic digestion and labeling from approximately 32 hours to a total of 3.5 hours.

Table 5. Intensity change of tryptic peptides from BSA and cyt *c* after replacing tryptic digestion in-solution with digestion using immobilized trypsin beads

Protein	Peptide sequence	<i>m/z</i>	Intensity change
BSA	LVTDLTK	395.24 ⁺²	-27.7 %
	AEFVEVTK	461.75 ⁺²	23.5 %
	YLYEIAR	464.25 ⁺²	11.3 %
	HLVDEPQNLIK	653.36 ⁺²	12.7 %
	KVPQVSTPTLVEVSR	547.32 ⁺³	240.2 %
	LVNELTEFAK	582.32 ⁺²	-3.8 %
	LGEYGFQNALIVR	740.40 ⁺²	71.2 %
	QTALVELLK	507.81 ⁺²	366.9 %
Cytochrome <i>c</i>	MIFAGIK	390.23 ⁺²	269.9 %
	TGPNLHGLFGR	390.21 ⁺³	231.8 %
	EDLIAYLK	482.77 ⁺²	1704.5 %
	EETLMEYLENPK	748.35 ⁺²	3794.3 %

3.3.3 Efficiency of the optimized procedure in urine samples

The developed integrated method was also tested in true urine samples to see the applicability in a complex and more protein rich matrix. Evaluation of the performance was done in urine samples spiked with a mixture of BSA and cyt *c* prior to tryptic digestion using the optimized procedure from section 3.3.2. The average ¹⁸O/¹⁶O-ratios of the 5 replicates ranged from 0.73 to 1.05 with an average of 0.88. RSD values below 16 % were observed in 4 out 5 samples, which is comparable to work published using iTRAQ where standard deviations less than 23 % were reported [59]. Another group investigating the variation of iTRAQ labeling has previously reported a coefficient of variation (CV) = 24 % [88], while Gan and coworkers classified the variation into different sources: technical (±11%), experimental (±23%) and biological (±25%) variation [89]. The variability of the integrated ¹⁸O/¹⁶O labeling approach was hence comparable or even

better than in the earlier reported works. Average $^{18}\text{O}/^{16}\text{O}$ ratios obtained in urine suggested complete labeling and low degree of back exchange. In order to confirm this, a sample of ^{18}O -labeled BSA in urine was analyzed *before* mixing with unlabeled peptides. Prospective peaks showing ^{16}O -labeled (not labeled) peptides could then only be caused by incomplete labeling or back exchange. The mass spectra of six of the ^{18}O -labeled BSA peptides are shown in Figure 21.

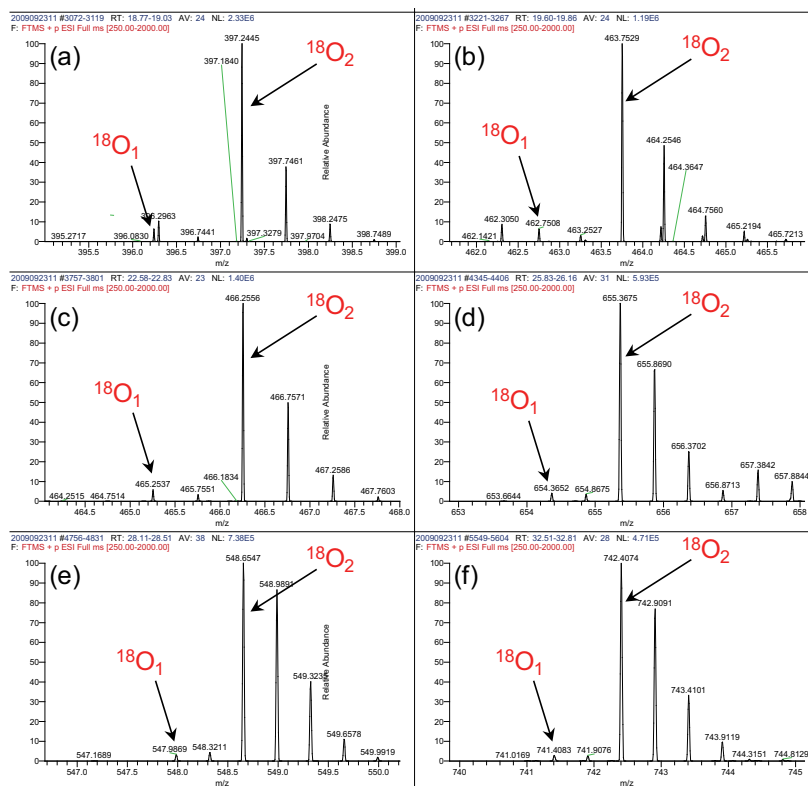

Figure 21. Orbitrap mass spectra of six ^{18}O -labeled BSA peptides before mixing with unlabeled peptides. (a) LVTDLTK, (b) AEFVEVTK, (c) YLYEIAR, (d) HLVDEPQNLIK, (e) KVPQVSTPTLVEVSR, (f) LGEYGFQNALIVR. Spectra were obtained from urine spiked with BSA, digested and labeled by immobilized trypsin

Traces of ^{16}O -peptides and singly ^{18}O -labeled peptides are visible in the mass spectra, but in low amounts relative to doubly ^{18}O -labeled (<3%). This is explained by the use of 97 % pure H_2^{18}O (thus having 3 % H_2^{16}O present). In other words, these results also support that

the labeling is complete and a very low degree of back exchange takes place. Application of the method on a realistic patient sample (kidney transplant) was the final test to evaluate the labeling efficiency in a broad range of peptides originating from urinary proteins. Another aspect was to see how the integrated digestion/labeling approach would function as part of a comprehensive proteomic experiment and how the results and variability would be affected. Figure 22 shows the ratio distribution of identified peptides in 2 replicate samples.

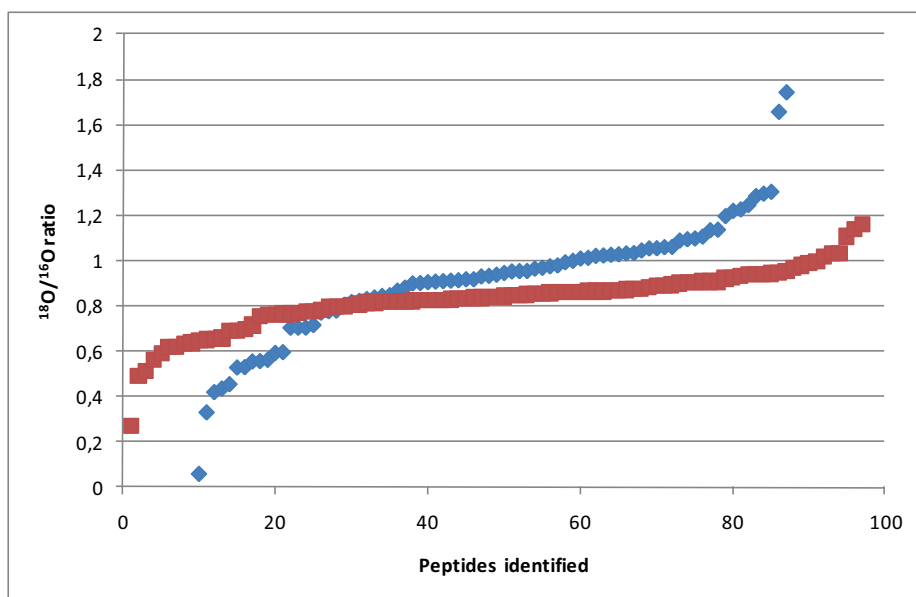

Figure 22. Ratio distribution of all $^{18}\text{O}/^{16}\text{O}$ -labeled peptides identified (x-axis) in urine from a kidney transplanted patient ($n = 2$). Both tryptic digestion and $^{18}\text{O}/^{16}\text{O}$ -labeling were done using immobilized trypsin

Average peptide ratios of 0.83 ± 0.13 and 0.91 ± 0.27 (no statistical significant difference) suggest that a high degree of labeling is achieved and the standard deviation also shows a relatively low degree of variation between the peptides. The respective median ratios were 0.84 and 0.94, indicating symmetric distribution. Based on these results, the integrated digestion/labeling approach was chosen for the further studies enabling rapid digestion and labeling without compromising on the quality.

3.4 Differential expressed proteins following acute rejection in renal transplant recipients

As pointed out in the introduction of this thesis, a better tool to diagnose acute rejection episodes is desired. To improve current methods, a specific and more sensitive biomarker that could be obtained non-invasively (urine) and detect initiating rejection episodes at an earlier time would have been of great value. Several attempts have been made to identify possible urinary markers predicting AR [90-101], but so far none of them are routinely used in a clinical setting [102,103]. Most of the studies done are hypothesis based and performed by analysis of a few specific targets. However, Sigdel et al. recently applied shotgun proteomics to identify possible AR markers in pediatric kidney transplants [100]. This is a less biased approach based on screening of all proteins that are possible to identify in a sample. A similar approach was chosen in this thesis using the LTQ-Orbitrap that benefits from a high mass resolution to identify proteins with a high degree of confidence. In the work of Sigdel et al., a label free quantification approach based on spectral counting was used. This is a semi-quantitative approach, which especially for low intensity peaks is less precise than quantification by stable isotopic labeling (e.g. $^{18}\text{O}/^{16}\text{O}$ -labeling) used in this thesis. The analyses were based on individual samples, not of pooled samples from many patients, avoiding bias from extreme individual changes in the proteome. In addition, analysis of individual samples also provides information on inter-individual variation. Detection of up-regulation of certain protein biomarkers in urine could provide a non-invasive and effective way to diagnose acute rejection episodes following renal transplantation.

3.4.1 Choice of patients and samples

In *Paper V*, urine were collected from renal transplant recipients as part of an ongoing clinical study (n=20) [83]. The patients were followed prospectively from the time they were transferred from the surgical department (typically five days after operation) and urine samples were collected until approximately 10 weeks after transplantation. The urine samples were collected several days each week and clinical data collected for the whole period. All suspected acute rejections were verified with a biopsy and classified according to Banff 97 [9]. In order to find proteins associated with AR, urine samples from the day a biopsy was taken to investigate if there was a true acute rejection episode were compared with the first urine sample available after transplantation (baseline) by the proteomic

method described and developed in this thesis. An overview of the samples compared is displayed in Figure 23. This approach, as compared to the more commonly used pooled sample strategy, also gives a more informative picture since inter-individual variability can be assessed. The AR sample was also compared with a sample obtained in a clinically stable phase 7-11 days prior to acute rejection (before increased plasma creatinine) in order to get information on protein levels close up to verified AR. Samples from 6 AR patients were analyzed and compared with a control group consisting of 6 subjects not experiencing AR in the same clinical trial. In the control group, baseline samples were compared with samples from a clinically stable phase post-transplant from the same patient matched in time against the AR-group.

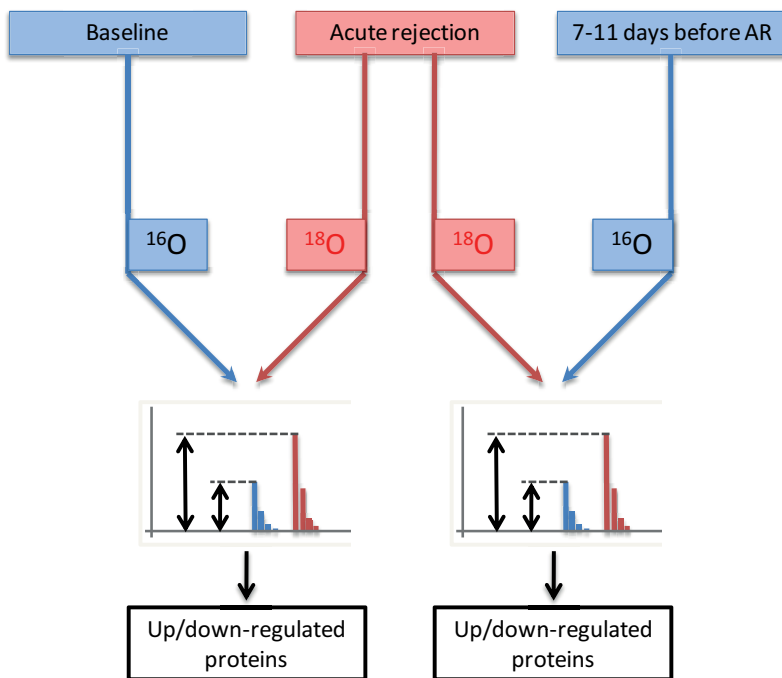

Figure 23. Scheme of the samples analyzed and compared from each patient

3.4.2 Up-regulated proteins

It was decided to focus on up-regulated proteins since these probably are the most relevant and interesting proteins in a clinical setting. Furthermore would an opposite labeling probably be more suitable to quantify down-regulated proteins. In particular for the highly down-regulated proteins where the isotope pattern from the unlabeled peptide peak would

interfere with the low signals from the labeled peptide giving uncertain quantification results. Hence would labeling of the baseline sample with the heavy tag (^{18}O) be more appropriate to avoid this effect. In order to identify proteins associated with AR, changes in protein levels from baseline to AR was investigated. Up-regulation of a certain protein was defined as a ≥ 1 fold log 2 change of the $^{18}\text{O}/^{16}\text{O}$ -ratios from baseline to AR. In other words; a doubling of the protein levels from baseline to AR would define a protein as up-regulated in a single patient. This high threshold minimizes the impact of methodological variability, which was substantially lower (calculated in section 3.1.4). The list of the most up-regulated proteins in this study was selected based on several criteria where the first was an up-regulation (fold change of ≥ 1 , log 2) in at least three patients in the rejection group. Further, proteins with higher average ratio in the control group and proteins more frequently up-regulated in the control group were excluded to remove proteins that increased in all patients after transplantation, thus probably unrelated to AR.

This resulted in a list of 11 proteins, which could be grouped by biological function in two main groups; proteins involved in regulation of growth and proteins involved in immune response. One protein, MEP1A, did not fit any of these groups and is presented individually. The list of grouped proteins and ratios in each patient of both the rejection and control group are showed in Table 6. Only the Mannan-binding lectin serin protease 2 (MASP2) was up regulated in all rejection patients. Grouping the proteins by biological functions substantiated however a potentially relevant regulation within these systems in the rejection group as compared with the control group. This was done by combining all proteins within each group of proteins into one score based on the log 2 changes from baseline. Figure 24 shows the change in protein levels for specified protein groups in the six patients experiencing AR.

A very interesting and important finding is the up-regulation detected several days prior to the acute rejection was clinically suspected as illustrated in Figure 24. Any rejection is an on-going process and it is well known that it takes time before creatinine increases enough ($>20\%$) so that a rejection is suspected. If the altered urine proteome turns out to be an earlier responding and more specific biomarker of acute rejection it could have dramatic implications on long term outcome of renal transplant recipients. It is possible that a minor adjustment of the immunosuppressive therapy would be enough to “silence” the early activated immune process and actually avoid full activation of the immune system. Sequential urine proteomic analysis could possibly serve as an

“immunometer” also during tapering of the initial high immunosuppressive load after engraftment. In this way it may hence serve as a tool to improve the individualization of the long term immunosuppression regime.

Table 6. Up-regulated proteins¹ in AR compared to baseline shown for individual patients

IPI ID	Gene ID	Protein name	Rejection group										No-rejection group					
			AR1 I ₃ T ₁ V ₀ C4d-	AR2 I ₂ T ₂ V ₀ C4d-	AR3 I ₂ T ₃ V ₀ C4d-	AR4 I ₂ T ₃ V ₀ C4d-	AR5 I ₂ T ₃ V ₀ C4d-	AR6 I ₃ T ₁ V ₂ C4d-	C1 NA	C2 NA	C3 NA	C4 NA	C5 NA	C6 NA				
			Log 2 change					Log 2 change										
Immune proteins																		
IP100217775.1	CD74	Isoform 2 of HLA class II histocompatibility antigen gamma chain	ND ¹	0.47	2.57	4.06	1.81	1.23	0.39	1.03	0.81	0.99	2.10	0.58				
IP100004573.2	PIGR	Polymorphic immunoglobulin receptor	-0.04	0.66	2.27	1.31	0.36	2.20	0.29	0.63	0.71	1.65	0.19	0.14				
IP100783987.2	C3	Complement C3 (Fragment)	-0.17	3.17	-0.48	1.25	-5.32	2.64	-3.49	ND	1.14	-4.80	-1.54	-3.63				
IP100017601.1	CP	Ceruloplasmin	0.42	4.40	0.34	1.15	ND	4.79	-1.87	-1.25	0.22	-1.02	0.53	-2.02				
IP100306378.5	MASP2	Isoform 2 of Mannan-binding lectin serine protease 2	1.10	1.88	1.36	2.30	1.26	4.06	0.57	-3.94	1.94	1.19	2.44	0.43				
IP100011302.1	CD59	CD59 glycoprotein	-2.65	1.16	1.30	1.74	0.40	3.62	-1.52	2.68	-1.90	1.73	1.31	0.19				
Growth factors																		
IP100016915.1	IGFBP7	Insulin-like growth factor-binding protein 7	0.11	-0.43	2.40	1.01	-0.91	2.84	0.71	1.42	0.05	0.58	-0.02	ND				
IP100966866.1	EGF	Epidermal growth factor	1.71	3.49	2.15	0.75	0.97	ND	0.79	ND	ND	1.51	0.51	0.13				
IP100395488.2	VASN	Vasorin	1.27	1.11	ND	0.61	0.05	2.10	0.96	-2.27	2.00	0.66	1.69	-0.81				
IP100023673.1	LGALS3BP	Galactin-3-binding protein	1.01	0.20	2.62	1.76	0.61	3.59	0.26	1.21	0.03	1.15	0.32	0.30				
Other																		
IP100004372.3	MEP1A	MEP1A protein (Meprin A subunit alpha)	ND	ND	1.87	2.87	1.31	1.02	ND	ND	ND	ND	ND	ND				

¹ Criteria for up-regulation: up-regulation (log 2 change ≥1) from baseline to AR in at least three patients in the AR group. Proteins with higher average ratio in the control group and proteins more frequently up-regulated in the control group were excluded.

² ND: Not detected

It was difficult to see a clear pattern related to Banff classification based on these data. There might, however, be a connection between severity of the rejection and the grade of up-regulation of the proteins. In the only patient with arterial changes (Banff 2 A) in the biopsy, the urine proteins were highly up-regulated with 10 of the 11 identified proteins elevated at the time of AR (the last was not detected). This is also supported by analysis of the samples from AR patient 1 (Table 6) which only experienced a borderline rejection. The analysis showed a relatively low degree of regulation, where only 4 of the 11 proteins were up-regulated.

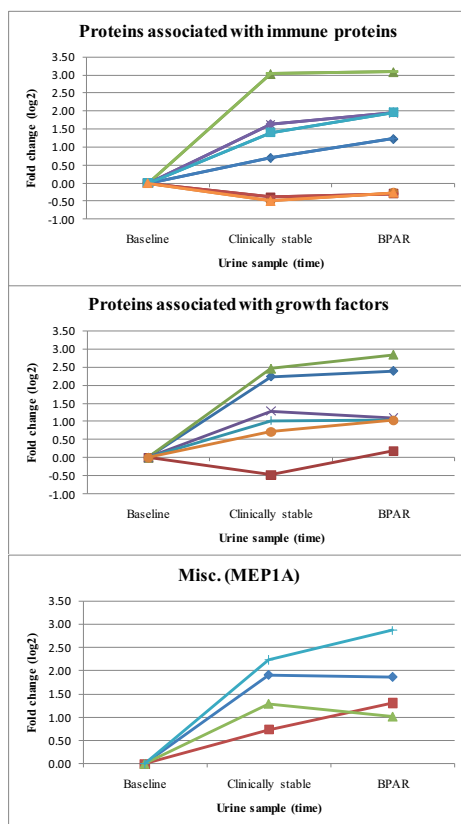

Figure 24. Fold change (\log_2) of immune proteins, growth factors and MEPIA in the rejection group, AR1 (●) AR2 (×) AR3 (◆) AR4 (+) AR5 (■) AR6 (▲), from baseline to Biopsy Proven Acute Rejection (BPAR). The center point (Clinically stable) is 7-11 days before BPAR, at stable serum creatinine levels.

All patients in the rejection group were regulated above the predefined threshold in at least one of the proteins groups of which no significant regulation was observed in the control group. Figure 25 shows a boxplot of the regulated proteins in both groups. The results show that the growth factors were statistically significant up-regulated in the rejection group compared with the control group ($P=0.03$).

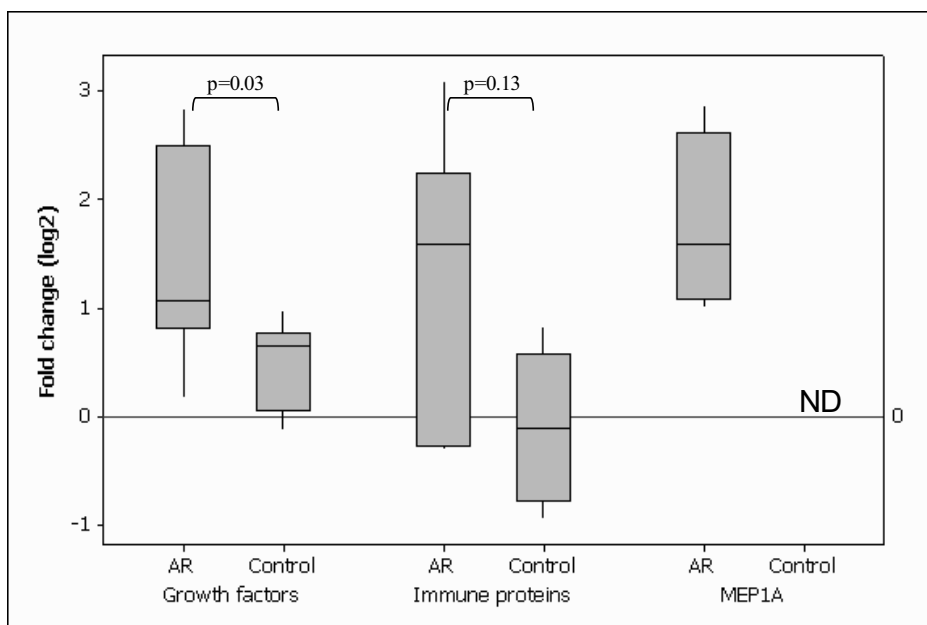

Figure 25. Boxplot showing fold change (\log_2) of immune proteins, growth factors and MEP1A from baseline to AR in the AR-group compared with the control group

The up-regulated proteins coupled to cell growth are involved in several biological processes. Insulin-like growth factor-binding protein 7 (IGFBP7) has shown to modulate effects of vascular endothelial growth factor (VEGF) [104] and is reported to interact with chemokines of, and act as a marker for activated endothelial cells [105,106]. One of the chemokines, IFN- γ -inducible protein 10 (IP-10; CXCL10), has also been reported to be elevated in urine during AR in kidney transplants [93,97]. Vasorin binds directly to transforming growth factor-beta ($TGF-\beta_1$) [107], previously reported to be involved in the pathogenesis of chronic renal allograft dysfunction [108,109]. The encoding gene of galectin-3-binding protein, LGALS3BP, is a broadly active immune stimulator associated with several types of immune cells [110]. Recently, the protein has been identified as a stimulant of Interleukin-6 (IL-6) expression in bone marrow stromal cells [111]. Interestingly, increased urinary levels of IL-6

have earlier been reported in association with acute rejection episodes in kidney transplants [95,112]. Epidermal growth factor (EGF), or pro-epidermal growth factor, is a large protein highly expressed in the kidney and has been reported to be reduced during AR in rats (gene expression) and humans (urinary excretion) [112,113].

For the immune proteins, up-regulation was observed in 4 out of 6 patients during AR showing a relatively strong increase of protein levels in the up-regulated patients. The immune proteins showed an overall trend of up-regulation in the rejection group, but not statistically significant ($P=0.13$) The 2 remaining patients in the rejection group actually showed a slight decrease during AR compared to baseline, mostly because of a strong down-regulation of acute phase proteins Complement C3 and CD59 glycoprotein in each of the patients respectively. CD59 exerts an inhibitory effect on the complement system and inclusion in the immune protein group can be discussed since it counteracts the effect of several of the other proteins. Interestingly, exclusion of CD59 from this group gives a significant difference between the AR and control group ($P=0.045$). In the control group most of the patients showed decreased levels of immune proteins compared to baseline, especially for the acute phase proteins where a strong down-regulation was observed in several patients. This is a somewhat different picture than from the proteins involved in growth, where the levels were relatively stable.

The proteins categorized in the immune related protein group are mainly acute phase proteins, but also proteins involved in antigen and immunoglobulin binding. HLA class II histo-compatibility antigen gamma chain (invariant chain or CD74) perform several activities affecting T-cells, B-cells and antigen presenting cells within the immune system [114]. The pro-inflammatory cytokine Macrophage migration inhibitory factor (MIF), which has a number of important immune functions like activation of macrophages and T-cells, is an extracellular ligand for CD74 in complex with CD44 [115,116]. MIF plays an important role in kidney disease and has been associated with AR in kidney transplants [90]. Mannan-binding lectin serin protease 2 (MASP2) is a protease that activates complement via the lectin pathway [117] and another protein identified as up-regulated, polymeric immunoglobulin receptor, has been linked to activation of the lectin pathway in patients with IgA nephropathy [118]. Moreover, both complement C3 and CD59 glycoprotein from the complement system was elevated during AR. Although the majority of C3 is produced in the liver, various cells of the kidney are capable of production and a pathogenic role of C3 during rejection episodes

has previously been suggested [119,120]. Ceruloplasmin is also a protein produced by the liver during the acute phase of an inflammatory response [121], and was reported to be quantitatively up-regulated during AR (pediatric kidney transplants) in the study performed by Sigdel et al. [100].

MEP1A protein levels were elevated during AR in all patients. The protein was however not detected in any of the patients in the control group. Meprins are highly expressed in the brush-border membranes of both kidney and intestine and has been associated with acute kidney injury in mice [122]. The absence of identified MEP1A in the control group is an interesting observation and could potentially be useful in a diagnostic setting. This needs however to be investigated more thoroughly to ensure that the observation is not due to methodological issues. The peptides related to MEP1A were however identified by the proteomic method with a high degree of confidence and all peptides were specific for the protein.

One major strength of the analysis is that each patient was his or her own control, comparing the protein levels during AR with the levels at baseline and individual samples were analyzed, not pooled urine. This provides a more detailed pattern of the protein regulation activated in association with an acute rejection. All identified proteins are physiological plausible to be involved in an acute rejection episode. Since we investigated sequential samples it was possible to identify that the activation of these proteins were present already more than a week prior to the clinical identification of the acute rejection. A limitation of this study is the lack of urine analysis after treatment of acute rejection episodes. Logically, a urinary biomarker of potential diagnostic value should return to baseline level as the acute rejection episode is successfully treated. Unfortunately these urines were not collected in the present trial and it was not possible to show this for the identified proteins in the present analysis. It should also be kept in mind that the control group patients were not verified non-rejectors by protocol biopsies. Previous studies where biopsies of stable patients treated with CsA were analyzed showed an incidence of almost 30 % subclinical rejections [123,124]. It is hence possible that subclinical rejections could be present in the control group, which in turn could affect the protein regulation in these patient group making the interpretation somewhat biased.

3.4.3 Comparison with earlier published data

Regarding earlier reported regulated proteins in urine associated to AR, several of these were also detected, but not significantly regulated, in the current study. Sigdel et al. used pooled samples and found a list of up- and down-regulated proteins, of which uromodulin, CD44 and SERPINF1 was investigated further [100]. The results showed down-regulation of uromodulin and CD44 and up-regulation of SERPINF1. Data from the present study of individual samples suggest a high degree of between patient variability in the regulation of uromodulin in the rejection group, showing highly elevated protein levels in 3 patients and a decrease in concentration in 2 of the patients. SERPINF1 did not show any clear regulation pattern while CD44 was increased during AR in 4 patients, but only in 1 of the patients was the up-regulation more than two-fold. Another study identified β -defensin-1 and α -1-antichymotrypsin as regulated in AR [125]. The data from *Paper V* also supports this to some extent. No obvious increase was observed during AR in the rejection group, but a distinct decrease was seen in the control group indicating a potential regulation of α -1-antichymotrypsin, even though it did not fulfill the present predefined criteria for regulation in the current study. In addition, other proteins have been investigated using a more targeted approach (e.g. ELISA) but these could not be supported by the current investigation [90-99,101]. However, several of these proteins (e.g. MIF, IP-10 and IL-6) are physiologically associated with the up-regulated proteins identified in our study as pointed out in section 3.4.2.

3.5 Future perspectives

The developed method has shown proof of concept in biomarker discovery of the present set-up by identifying several urinary proteins associated with acute rejection episodes in kidney transplants in this pilot study. Before this can be used in a clinical setting, validation must be carried out in a larger population. There are several paths that can be used, but a more targeted method monitoring only the proteins of interest is probably necessary to be able to analyze the large number of urine samples that such a study would demand. One possible approach is antibody mediated clean-up of the proteins using e.g. ELISA perhaps in combination with LC-MS/MS. Another technique which could be used is Multiple Reaction Monitoring (MRM) of unique peptide products from the proteins of interest. Both of these techniques can be carried out without the extensive sample preparation and without the need

of multidimensional chromatography, reducing both the workload and time used for each sample.

In order to remove doubt over possible sub-clinical rejections not discovered in the no-rejection group, the control group should preferably consist of kidney transplanted that are confirmed non-rejectors. This could be done by analysis of urine samples at the time of protocol biopsies.

The kinetics of the identified proteins has not been investigated in the present study. This would demand analysis of sequential samples from each patient to find the exact timing of the increase in protein concentration. Such information could be very valuable from a clinical point of view. This would however also demand a large amount of samples and a more targeted approach would hence be more appropriate as mentioned above.

4 Concluding remarks

In the presented work a proteomic method has been developed and optimized in order to analyze urine from kidney transplanted patients. By applying the developed method several proteins potentially associated with acute rejection episodes were successfully identified. The biological functions of the identified proteins were mainly related to immune response and growth functions. The group of proteins related to growth was significantly up-regulated and included the proteins IGFBP7, Vasorin, EGF and Galectin-3-binding protein. For the proteins related to immune response, MASP2, C3, CD59, Ceruloplasmin, PiGR and CD74, there was a strong tendency towards up-regulation. Up-regulation of both groups tended to appear before current diagnostic tools were able to set the diagnosis in the patient group. This could make the proteins useful in a clinical setting enabling earlier recognition of acute rejection episodes in a non-invasive manner. There is however a need for validation of the proteins in a larger population and development of a less labor- and time-demanding method.

In the development phase of the method, downstream compatibility was one of the key words. The result was a method with a minimal amount of sample handling between each step to eliminate possible sources of variability. Several approaches to tryptic digestion of proteins were also tested, introducing immobilized trypsin and different technical solutions. The format of choice was immobilized trypsin beads which enabled tryptic digestion of proteins with the same quality as the standard *in-solution* digestion, but within a substantially shorter timeframe.

A complete on-line method including all steps in a proteomic workflow was also evaluated. The results were promising and the potential for automation is very interesting, but the method was too premature and not ready for use in biomarker discovery yet.

A significant improvement of the standard tryptic digestion and $^{18}\text{O}/^{16}\text{O}$ -labeling procedures were accomplished by making an integrated approach utilizing immobilized trypsin beads for both steps. The developed method is a time efficient alternative for quantification in urinary proteomics by stable isotope labeling. By integrating all procedures keeping the sample in one sample reactor, the recovery was improved and the variability reduced.

Two-dimensional chromatographic separation of the complex urinary tryptic digest was successfully carried out combining HILIC and RP. This yielded a relative orthogonal separation of the tryptic peptides increasing greatly the number of peptides detectable. After implementation of nanoscale RP separation in the final optimized method, over 1000 proteins were identified in one single sample.

5 References

- [1] V. Thongboonkerd. Recent progress in urinary proteomics. *Proteomics - Clinical Applications*. 2007; **1**: 780-791.
- [2] R. Pieper, C.L. Gatlin, A.M. McGrath, A.J. Makusky, M. Mondal, M. Seonarain, E. Field, C.R. Schatz, M.A. Estock, N. Ahmed, N.G. Anderson, S. Steiner. Characterization of the human urinary proteome: A method for high-resolution display of urinary proteins on two-dimensional electrophoresis gels with a yield of nearly 1400 distinct protein spots. *Proteomics*. 2004; **4**: 1159-1174.
- [3] J.W. Groothoff. Long-term outcomes of children with end-stage renal disease. *Pediatric Nephrology*. 2005; **20**: 849-853.
- [4] T. Leivestad. Annual report 2009 - The Norwegian Renal Registry. 2009.
- [5] T. Leivestad. Annual report 2004 - The Norwegian Renal Registry. 2004.
- [6] K.L. Womer, B. Kaplan. Recent Developments in Kidney Transplantation—A Critical Assessment. *American Journal of Transplantation*. 2009; **9**: 1265-1271.
- [7] L.D. Cornell, R.N. Smith, R.B. Colvin. Kidney Transplantation: Mechanisms of Rejection and Acceptance. *Annual Review of Pathology: Mechanisms of Disease*. 2008; **3**: 189-220.
- [8] R.B. Colvin. Antibody-Mediated Renal Allograft Rejection: Diagnosis and Pathogenesis. *Journal of the American Society of Nephrology*. 2007; **18**: 1046-1056.
- [9] L.C. Racusen, K. Solez, R.B. Colvin, S.M. Bonsib, M.C. Castro, T. Cavallo, B.P. Croker, A.J. Demetris, C.B. Drachenberg, A.B. Fogo, P. Furness, L.W. Gaber, I.W. Gibson, D. Glotz, J.C. Goldberg, J. Grande, P.F. Halloran, H.E. Hansen, B. Hartley, P.J. Hayry, C.M. Hill, E.O. Hoffman, L.G. Hunsicker, A.S. Lindblad, N. Marcussen, M.J. Mihatsch, T. Nadasdy, P. Nickerson, T.S. Olsen, J.C. Papadimitriou, P.S. Randhawa, D.C. Rayner, I. Roberts, S. Rose, D. Rush, L. Salinas-Madrigal, D.R. Salomon, S. Sund, E. Taskinen, K. Trpkov, Y. Yamaguchi. The Banff 97 working classification of renal allograft pathology. *Kidney Int*. 1999; **55**: 713-723.
- [10] P.S. Almond, A. Matas, K. Gillingham, D.L. Dunn, W.D. Payne, P. Gores, R. Gruessner, J.S. Najarian, Ferguson, Paul, Schaffer. Risk-Factors for Chronic Rejection in Renal-Allograft Recipients. *Transplantation*. 1993; **55**: 752-757.
- [11] S. Hariharan, C.P. Johnson, B.A. Bresnahan, S.E. Taranto, M.J. McIntosh, D. Stablein. Improved Graft Survival after Renal Transplantation in the United States, 1988 to 1996. *New England Journal of Medicine*. 2000; **342**: 605-612.
- [12] B. Kaplan. Overcoming barriers to long-term graft survival. *American Journal of Kidney Diseases*. 2006; **47**: S52-S64.
- [13] H.U. Meier-Kriesche, A.O. Ojo, J.A. Hanson, D.M. Cibrik, J.D. Pusch, A.B. Leichtman, B. Kaplan. Increased impact of acute rejection on chronic allograft failure in recent era. *Transplantation*. 2000; **70**: 1098-1100.
- [14] B.J. Nankivell, J.R. Chapman. Chronic allograft nephropathy: current concepts and future directions. *Transplantation*. 2006; **81**: 643-654.
- [15] R.P. Pelletier, F. Cosio, M.L. Henry, G.L. Bumgardner, E.A. Davies, E.A. Elkhammas, R.M. Ferguson. Acute rejection following renal transplantation. Evidence that severity is the best predictor of subsequent graft survival time. *Clinical Transplantation*. 1998; **12**: 543-552.
- [16] A. Humar, S. Kerr, K.J. Gillingham, A.J. Matas. Features of acute rejection that increase risk for chronic rejection. *Transplantation*. 1999; **68**: 1200-1203.
- [17] A. Ishikawa, S.M. Flechner, D.A. Goldfarb, J.L. Myles, C.S. Modlin, N. Boparai, D. Papajcik, B. Mastroianni, A.C. Novick. Quantitative assessment of the first acute

- rejection as a predictor of renal transplant outcome. *Transplantation*. 1999; **68**: 1318-1324.
- [18] E. O'Riordan, S.S. Gross, M.S. Goligorsky. Technology Insight: renal proteomics - at the crossroads between promise and problems. *Nature Clinical Practice Nephrology*. 2006; **2**: 445-458.
- [19] W.P. Blackstock, M.P. Weir. Proteomics: quantitative and physical mapping of cellular proteins. *Trends in Biotechnology*. 1999; **17**: 121-127.
- [20] V. Thongboonkerd, S. Chutipongtanate, R. Kanlaya. Systematic evaluation of sample preparation methods for gel-based human urinary proteomics: Quantity, quality, and variability. *Journal of Proteome Research*. 2006; **5**: 183-191.
- [21] A. Khan, N.H. Packer. Simple urinary sample preparation for proteomic analysis. *Journal of Proteome Research*. 2006; **5**: 2824-2838.
- [22] T.K. Sigdel, K. Lau, J. Schilling, M. Sarwal. Optimizing protein recovery for urinary proteomics, a tool to monitor renal transplantation. *Clinical Transplantation*. 2008; **22**: 617-623.
- [23] R.S. Lee, F. Monigatti, A.C. Briscoe, Z. Waldon, M.R. Freeman, H. Steen. Optimizing Sample Handling for Urinary Proteomics. *Journal of Proteome Research*. 2008; **7**: 4022-4030.
- [24] J.W. Zolg, H. Langen. How industry is approaching the search for new diagnostic markers and biomarkers. *Molecular & Cellular Proteomics*. 2004; **3**: 345-354.
- [25] N. Rifai, M.A. Gillette, S.A. Carr. Protein biomarker discovery and validation: the long and uncertain path to clinical utility. *Nature Biotechnology*. 2006; **24**: 971-983.
- [26] M. Fountoulakis, J.F. Juranville, L. Jiang, D. Avila, D. Roder, P. Jakob, P. Berndt, S. Evers, H. Langen. Depletion of the high-abundance plasma proteins. *Amino Acids*. 2004; **27**: 249-259.
- [27] Y.F. Shen, J. Kim, E.F. Strittmatter, J.M. Jacobs, D.G. Camp, R.H. Fang, N. Tolie, R.J. Moore, R.D. Smith. Characterization of the human blood plasma proteome. *Proteomics*. 2005; **5**: 4034-4045.
- [28] J. Adachi, C. Kumar, Y.L. Zhang, J.V. Olsen, M. Mann. The human urinary proteome contains more than 1500 proteins, including a large proportion of membrane proteins. *Genome Biology*. 2006; **7**: R80.
- [29] R. Aebersold, M. Mann. Mass spectrometry-based proteomics. *Nature*. 2003; **422**: 198-207.
- [30] J.V. Olsen, S.-E. Ong, M. Mann. Trypsin Cleaves Exclusively C-terminal to Arginine and Lysine Residues. *Molecular & Cellular Proteomics*. 2004; **3**: 608-614.
- [31] T.D. Lee, J.E. Shively, in A.M. James (Editor), *Methods in Enzymology*, Academic Press, 1990, p. 361-374.
- [32] Y. Li, X. Xu, C. Deng, P. Yang, X. Zhang. Immobilization of Trypsin on Superparamagnetic Nanoparticles for Rapid and Effective Proteolysis. *Journal of Proteome Research*. 2007; **6**: 3849-3855.
- [33] J.R. Freije, P. Mulder, W. Werkman, L. Rieux, H.A.G. Niederlander, E. Verpoorte, R. Bischoff. Chemically modified, immobilized trypsin reactor with improved digestion efficiency. *Journal of Proteome Research*. 2005; **4**: 1805-1813.
- [34] S. Ota, S. Miyazaki, H. Matsuoka, K. Morisato, Y. Shintani, K. Nakanishi. High-throughput protein digestion by trypsin-immobilized monolithic silica with pipette-tip formula. *Journal of Biochemical and Biophysical Methods*. 2007; **70**: 57-62.
- [35] J. Ma, L. Zhang, Z. Liang, W. Zhang, Y. Zhang. Recent advances in immobilized enzymatic reactors and their applications in proteome analysis. *Analytica Chimica Acta*. 2009; **632**: 1-8.

- [36] G. Massolini, E. Calleri. Immobilized trypsin systems coupled on-line to separation methods: Recent developments and analytical applications. *Journal of Separation Science*. 2005; **28**: 7-21.
- [37] I. Neverova, J.E. Van Eyk. Role of chromatographic techniques in proteomic analysis. *Journal of Chromatography B-Analytical Technologies in the Biomedical and Life Sciences*. 2005; **815**: 51-63.
- [38] V. Thongboonkerd, K.R. McLeish, J.M. Arthur, J.B. Klein. Proteomic analysis of normal human urinary proteins isolated by acetone precipitation or ultracentrifugation. *Kidney International*. 2002; **62**: 1461-1469.
- [39] G.D. Chen, B.N. Pramanik. LC-MS for protein characterization: current capabilities and future trends. *Expert Review of Proteomics*. 2008; **5**: 435-444.
- [40] W.H. McDonald, J.R. Yates. Shotgun proteomics and biomarker discovery. *Disease Markers*. 2002; **18**: 99-105.
- [41] W.S. Hancock, S.L. Wu, P. Shieh. The challenges of developing a sound proteomics strategy. *Proteomics*. 2002; **2**: 352-359.
- [42] J.C. Giddings. CONCEPTS AND COMPARISONS IN MULTIDIMENSIONAL SEPARATION. *Journal of High Resolution Chromatography & Chromatography Communications*. 1987; **10**: 319-323.
- [43] W. Sun, F.X. Li, S.Z. Wu, X.R. Wang, D.X. Zheng, J. Wang, Y.H. Gao. Human urine proteome analysis by three separation approaches. *Proteomics*. 2005; **5**: 4994-5001.
- [44] Q.C. Ru, R.A. Katenhusen, L.A. Zhu, J. Silberman, S. Yang, T.J. Orchard, H. Brzeski, M. Liebman, D.L. Ellsworth. Proteomic profiling of human urine using multi-dimensional protein identification technology. *Journal of Chromatography A*. 2006; **1111**: 166-174.
- [45] M.P. Washburn, D. Wolters, J.R. Yates. Large-scale analysis of the yeast proteome by multidimensional protein identification technology. *Nature Biotechnology*. 2001; **19**: 242-247.
- [46] P. Hemstrom, K. Irgum. Hydrophilic interaction chromatography. *Journal of Separation Science*. 2006; **29**: 1784-1821.
- [47] P. Jandera. Stationary phases for hydrophilic interaction chromatography, their characterization and implementation into multidimensional chromatography concepts. *Journal of Separation Science*. 2008; **31**: 1421-1437.
- [48] P.J. Boersema, N.N. Divecha, A.J.R. Heck, S.S. Mohammed. Evaluation and optimization of ZIC-HILIC-RP as an alternative MudPIT strategy. *Journal of proteome research*. 2007; **6**: 937-946.
- [49] M. Gilar, P. Olivova, A.E. Daly, J.C. Gebler. Orthogonality of separation in two-dimensional liquid chromatography. *Analytical Chemistry*. 2005; **77**: 6426-6434.
- [50] M. Gilar, P. Olivova, A.E. Daly, J.C. Gebler. Two-dimensional separation of peptides using RP-RP-HPLC system with different pH in first and second separation dimensions. *Journal of Separation Science*. 2005; **28**: 1694-1703.
- [51] A. Makarov. Electrostatic axially harmonic orbital trapping: A high-performance technique of mass analysis. *Analytical Chemistry*. 2000; **72**: 1156-1162.
- [52] M. Scigelova, A. Makarov. Orbitrap Mass Analyzer – Overview and Applications in Proteomics. *PROTEOMICS*. 2006; **6**: 16-21.
- [53] Q. Hu, R.J. Noll, H. Li, A. Makarov, M. Hardman, R. Graham Cooks. The Orbitrap: a new mass spectrometer. *Journal of Mass Spectrometry*. 2005; **40**: 430-443.
- [54] J.V. Olsen, L.M.F. de Godoy, G. Li, B. Macek, P. Mortensen, R. Pesch, A. Makarov, O. Lange, S. Horning, M. Mann. Parts per Million Mass Accuracy on an Orbitrap

- Mass Spectrometer via Lock Mass Injection into a C-trap. *Molecular & Cellular Proteomics*. 2005; **4**: 2010-2021.
- [55] R.A. Zubarev, P. Hakansson, B. Sundqvist. Accuracy requirements for peptide characterization by monoisotopic molecular mass measurements. *Analytical Chemistry*. 1996; **68**: 4060-4063.
- [56] J.R. Yates, D. Cociorva, L. Liao, V. Zabrouskov. Performance of a Linear Ion Trap-Orbitrap Hybrid for Peptide Analysis. *Analytical Chemistry*. 2005; **78**: 493-500.
- [57] M.H. Elliott, D.S. Smith, C.E. Parker, C. Borchers. Current trends in quantitative proteomics. *Journal of Mass Spectrometry*. 2009; **44**: 1637-1660.
- [58] S.P. Gygi, B. Rist, S.A. Gerber, F. Turecek, M.H. Gelb, R. Aebersold. Quantitative analysis of complex protein mixtures using isotope-coded affinity tags. *Nature Biotechnology*. 1999; **17**: 994-999.
- [59] P.L. Ross, Y.L.N. Huang, J.N. Marchese, B. Williamson, K. Parker, S. Hattan, N. Khainovski, S. Pillai, S. Dey, S. Daniels, S. Purkayastha, P. Juhasz, S. Martin, M. Bartlet-Jones, F. He, A. Jacobson, D.J. Pappin. Multiplexed protein quantitation in *Saccharomyces cerevisiae* using amine-reactive isobaric tagging reagents. *Molecular & Cellular Proteomics*. 2004; **3**: 1154-1169.
- [60] A. Thompson, J. Schafer, K. Kuhn, S. Kienle, J. Schwarz, G. Schmidt, T. Neumann, C. Hamon. Tandem mass tags: A novel quantification strategy for comparative analysis of complex protein mixtures by MS/MS. *Analytical Chemistry*. 2003; **75**: 1895-1904.
- [61] X. Yao, A. Freas, J. Ramirez, P.A. Demirev, C. Fenselau. Proteolytic ¹⁸O Labeling for Comparative Proteomics: Model Studies with Two Serotypes of Adenovirus. *Analytical Chemistry*. 2001; **73**: 2836-2842.
- [62] S. Decramer, A.G. de Peredo, B. Breuil, H. Mischak, B. Monsarrat, J.L. Bascands, J.P. Schanstra. Urine in Clinical Proteomics. *Molecular & Cellular Proteomics*. 2008; **7**: 1850-1862.
- [63] V. Thongboonkerd. Practical Points in Urinary Proteomics. *Journal of Proteome Research*. 2007; **6**: 3881-3890.
- [64] S. Julka, F. Regnier. Quantification in Proteomics through Stable Isotope Coding: A Review. *Journal of Proteome Research*. 2004; **3**: 350-363.
- [65] Y.K. Wang, Z. Ma, D.F. Quinn, E.W. Fu. Inverse ¹⁸O Labeling Mass Spectrometry for the Rapid Identification of Marker/Target Proteins. *Analytical Chemistry*. 2001; **73**: 3742-3750.
- [66] J.L. Capelo, R.J. Carreira, L. Fernandes, C. Lodeiro, H.M. Santos, J. Simal-Gandara. Latest developments in sample treatment for O-¹⁸-isotopic labeling for proteomics mass spectrometry-based approaches: A critical review. *Talanta*. 2010; **80**: 1476-1486.
- [67] M. Bantscheff, M. Schirle, G. Sweetman, J. Rick, B. Kuster. Quantitative mass spectrometry in proteomics: a critical review. *Analytical and Bioanalytical Chemistry*. 2007; **389**: 1017-1031.
- [68] X. Yao, C. Afonso, C. Fenselau. Dissection of Proteolytic ¹⁸O Labeling: Endoprotease-Catalyzed ¹⁶O-to-¹⁸O Exchange of Truncated Peptide Substrates. *Journal of Proteome Research*. 2003; **2**: 147-152.
- [69] D. Hajkova, K.C.S. Rao, M. Miyagi. pH dependency of the carboxyl oxygen exchange reaction catalyzed by lysyl endopeptidase and trypsin. *Journal of Proteome Research*. 2006; **5**: 1667-1673.
- [70] D. López-Ferrer, T.H. Heibeck, K. Petritis, K.K. Hixson, W. Qian, M.E. Monroe, A. Mayampurath, R.J. Moore, M.E. Belov, D.G. Camp, R.D. Smith. Rapid Sample

- Processing for LC-MS-Based Quantitative Proteomics Using High Intensity Focused Ultrasound. *Journal of Proteome Research*. 2008; **7**: 3860-3867.
- [71] G. Kris, I. Francis, G. Bart, D. Petra Van, L. Anja, V. Joël. Stable isotopic labeling in proteomics. *Proteomics*. 2008; **8**: 4873-4885.
- [72] J.R. Sevinsky, K.J. Brown, B.J. Cargile, J.L. Bundy, J.L. Stephenson. Minimizing back exchange in O-18/O-16 quantitative proteomics experiments by incorporation of immobilized trypsin into the initial digestion step. *Analytical Chemistry*. 2007; **79**: 2158-2162.
- [73] A. Ramos-Fernandez, D. Lopez-Ferrer, J. Vazquez. Improved method for differential expression proteomics using trypsin-catalyzed O-18 labeling with a correction for labeling efficiency. *Molecular & Cellular Proteomics*. 2007; **6**: 1274-1286.
- [74] K.J. Brown, C. Fenselau. Investigation of Doxorubicin Resistance in MCF-7 Breast Cancer Cells Using Shot-Gun Comparative Proteomics with Proteolytic 18O Labeling. *Journal of Proteome Research*. 2004; **3**: 455-462.
- [75] M. Mann, P. Højrup, P. Roepstorff. Use of mass spectrometric molecular weight information to identify proteins in sequence databases. *Biological Mass Spectrometry*. 1993; **22**: 338-345.
- [76] P. James, M. Quadroni, E. Carafoli, G. Gonnet. Protein Identification by Mass Profile Fingerprinting. *Biochemical and Biophysical Research Communications*. 1993; **195**: 58-64.
- [77] J.R. Yates, S. Speicher, P.R. Griffin, T. Hunkapiller. Peptide Mass Maps: A Highly Informative Approach to Protein Identification. *Analytical Biochemistry*. 1993; **214**: 397-408.
- [78] D.J.C. Pappin, P. Hojrup, A.J. Bleasby. Rapid identification of proteins by peptide-mass fingerprinting. *Current Biology*. 1993; **3**: 327-332.
- [79] W.J. Henzel, T.M. Billeci, J.T. Stults, S.C. Wong, C. Grimley, C. Watanabe. Identifying proteins from two-dimensional gels by molecular mass searching of peptide fragments in protein sequence databases. *Proceedings of the National Academy of Sciences of the United States of America*. 1993; **90**: 5011-5015.
- [80] D.N. Perkins, D.J.C. Pappin, D.M. Creasy, J.S. Cottrell. Probability-based protein identification by searching sequence databases using mass spectrometry data. *Electrophoresis*. 1999; **20**: 3551-3567.
- [81] J.K. Eng, A.L. McCormack, J.R. Yates. An Approach to Correlate Tandem Mass-Spectral Data of Peptides with Amino-Acid-Sequences in a Protein Database. *Journal of the American Society for Mass Spectrometry*. 1994; **5**: 976-989.
- [82] A. Shevchenko, O.N. Jensen, A.V. Podtelejnikov, F. Sagliocco, M. Wilm, O. Vorm, P. Mortensen, A. Shevchenko, H. Boucherie, M. Mann. Linking genome and proteome by mass spectrometry: Large-scale identification of yeast proteins from two dimensional gels. *Proceedings of the National Academy of Sciences of the United States of America*. 1996; **93**: 14440-14445.
- [83] P. Falck, A. Asberg, H. Guldseth, S. Bremer, F. Akhlaghi, J.L.E. Reubsæet, P. Pfeffer, A. Hartmann, K. Midtvedt. Declining intracellular T-lymphocyte concentration of cyclosporine a precedes acute rejection in kidney transplant recipients. *Transplantation*. 2008; **85**: 179-184.
- [84] B.Q. Tran, M. Pepaj, E. Lundanes, T. Greibrokk. On-line method for identification of native proteins using pH-gradient SAX chromatography and reversed phase chromatography-mass spectrometry of tryptic peptides. *Journal of Liquid Chromatography & Related Technologies*. 2008; **31**: 1387-1411.

- [85] Q.C. Ru, L.A. Zhu, R.A. Katenhusen, J. Silberman, H. Brzeski, M. Liebman, C.D. Shriver. Exploring human plasma proteome strategies: High efficiency in-solution digestion protocol for multi-dimensional protein identification technology. *Journal of Chromatography A*. 2006; **1111**: 175-191.
- [86] Hervey, M.B. Strader, G.B. Hurst. Comparison of Digestion Protocols for Microgram Quantities of Enriched Protein Samples. *Journal of Proteome Research*. 2007; **6**: 3054-3061.
- [87] A. Shevchenko, A. Shevchenko. Evaluation of the efficiency of in-gel digestion of proteins by peptide isotopic labeling and MALDI mass spectrometry. *Analytical Biochemistry*. 2001; **296**: 279-283.
- [88] H.C. Leila, A. Kunal, F. Zsofia, H.L. Kelvin. A comparison of the consistency of proteome quantitation using two-dimensional electrophoresis and shotgun isobaric tagging in *Escherichia coli* cells. *Electrophoresis*. 2005; **26**: 2437-2449.
- [89] C.S. Gan, P.K. Chong, T.K. Pham, P.C. Wright. Technical, Experimental, and Biological Variations in Isobaric Tags for Relative and Absolute Quantitation (iTRAQ). *Journal of Proteome Research*. 2007; **6**: 821-827.
- [90] F.G. Brown, D.J. Nikolich-Paterson, S.J. Chadban, J. Dowling, M. Jose, C.N. Metz, R. Bucala, R.C. Atkins. Urine macrophage migration inhibitory factor concentrations as a diagnostic tool in human renal allograft rejection. *Transplantation*. 2001; **71**: 1777-1783.
- [91] C. Donadio, R. Puccini, A. Lucchesi, R. Giordani, G. Rizzo. Urinary excretion of proteins and tubular enzymes in renal transplant patients. *Renal Failure*. 1998; **20**: 707-715.
- [92] R.K. Gupta, M. Jain, R.K. Sharma. Serum & urinary interleukin-2 levels as predictors in acute renal allograft rejection. *Indian Journal of Medical Research*. 2004; **119**: 24-27.
- [93] I.A. Hauser, S. Spiegler, E. Kiss, S. Gauer, O. Sichler, E.H. Scheuermann, H. Ackermann, J.M. Pfeilschifter, H. Geiger, H.-J. Gröne, H.H. Radeke. Prediction of Acute Renal Allograft Rejection by Urinary Monokine Induced by IFN- γ (MIG). *Journal of the American Society of Nephrology*. 2005; **16**: 1849-1858.
- [94] H. Hu, B.D. Aizenstein, A. Puchalski, J.A. Burmania, M.M. Hamawy, S.J. Knechtle. Elevation of CXCR3-Binding Chemokines in Urine Indicates Acute Renal-Allograft Dysfunction. *American Journal of Transplantation*. 2004; **4**: 432-437.
- [95] J. Kaden, R. Priesterjahn. Increasing urinary IL-6 levels announce kidney graft rejection. *Transplant International*. 2000; **13**: S34-S41.
- [96] S.R. Lederer, N. Friedrich, C. Regenbogen, R. Getto, M. Toepfer, T. Sitter. Non-Invasive Monitoring of Renal Transplant Recipients: Urinary Excretion of Soluble Adhesion Molecules and of the Complement-Split Product C4d. *Nephron Clinical Practice*. 2003; **94**: c19-c26.
- [97] M. Matz, J. Beyer, D. Wunsch, M.F. Mashreghi, M. Seiler, J. Pratschke, N. Babel, H.D. Volk, P. Reinke, K. Kotsch. Early post-transplant urinary IP-10 expression after kidney transplantation is predictive of short- and long-term graft function. *Kidney Int*. 2006; **69**: 1683-1690.
- [98] W.S. Oetting, T.B. Rogers, T.P. Krick, A.J. Matas, H.N. Ibrahim. Urinary beta(2)-microglobulin is associated with acute renal allograft rejection. *American Journal of Kidney Diseases*. 2006; **47**: 898-904.
- [99] J.J.T.H. Roelofs, A.T. Rowshani, J.G. Van Den Berg, N. Claessen, J. Aten, I.J.M. Ten Berge, J.J. Weening, S. Florquin. Expression of urokinase plasminogen activator and its receptor during acute renal allograft rejection. *Kidney Int*. 2003; **64**: 1845-1853.

- [100] T.K. Sigdel, A. Kaushal, M. Gritsenko, A.D. Norbeck, W.-J. Qian, W. Xiao, D.G.C. II, R.D. Smith, M.M. Sarwal. Shotgun proteomics identifies proteins specific for acute renal transplant rejection. *Proteomics - Clinical Applications*. 2010; **4**: 32-47.
- [101] A.M. Teppo, E. von Willebrand, E. Honkanen, J. Ahonen, C. Gronhagen-Riska. Soluble intercellular adhesion molecule-1 (sICAM-1) after kidney transplantation: The origin and role of urinary sICAM-1? *Transplantation*. 2001; **71**: 1113-1119.
- [102] W. Gwinner. Renal transplant rejection markers. *World Journal of Urology*. 2007; **25**: 445-455.
- [103] V. Thongboonkerd, P. Malasit. Renal and urinary proteomics: Current applications and challenges. *Proteomics*. 2005; **5**: 1033-1042.
- [104] K. Tamura, K. Hashimoto, K. Suzuki, M. Yoshie, M. Kutsukake, T. Sakurai. Insulin-like growth factor binding protein-7 (IGFBP7) blocks vascular endothelial cell growth factor (VEGF)-induced angiogenesis in human vascular endothelial cells. *European Journal of Pharmacology*. 2009; **610**: 61-67.
- [105] D. Nagakubo, T. Murai, T. Tanaka, T. Usui, M. Matsumoto, K. Sekiguchi, M. Miyasaka. A High Endothelial Venule Secretory Protein, Mac25/Angiomodulin, Interacts with Multiple High Endothelial Venule-Associated Molecules Including Chemokines. *The Journal of Immunology*. 2003; **171**: 553-561.
- [106] T. Usui, T. Murai, T. Tanaka, K. Yamaguchi, D. Nagakubo, C.M. Lee, M. Kiyomi, S. Tamura, Y. Matsuzawa, M. Miyasaka. Characterization of mac25/angiomodulin expression by high endothelial venule cells in lymphoid tissues and its identification as an inducible marker for activated endothelial cells. *International Immunology*. 2002; **14**: 1273-1282.
- [107] Y. Ikeda, Y. Imai, H. Kumagai, T. Nosaka, Y. Morikawa, T. Hisaoka, I. Manabe, K. Maemura, T. Nakaoka, T. Imamura, K. Miyazono, I. Komuro, R. Nagai, T. Kitamura. Vasorin, a transforming growth factor β -binding protein expressed in vascular smooth muscle cells, modulates the arterial response to injury in vivo. *Proceedings of the National Academy of Sciences of the United States of America*. 2004; **101**: 10732-10737.
- [108] J.M. Campistol, P. Iñigo, S. Larios, M. Bescos, F. Oppenheimer. Role of transforming growth factor- β 1 in the progression of chronic allograft nephropathy. *Nephrology Dialysis Transplantation*. 2001; **16**: 114-116.
- [109] F.S. Shihab, A.M. Tanner, Y. Shao, M.I. Weffer. Expression of TGF- β 1 and matrix proteins is elevated in rats with chronic rejection. *Kidney Int*. 1996; **50**: 1904-1913.
- [110] A. Ullrich, I. Sures, M. D'Egidio, B. Jallal, T.J. Powell, R. Herbst, A. Dreps, M. Azam, M. Rubinstein, C. Natoli. The secreted tumor-associated antigen 90K is a potent immune stimulator. *Journal of Biological Chemistry*. 1994; **269**: 18401-18407.
- [111] Y. Fukaya, H. Shimada, L.-C. Wang, E. Zandi, Y.A. DeClerck. Identification of Galectin-3-binding Protein as a Factor Secreted by Tumor Cells That Stimulates Interleukin-6 Expression in the Bone Marrow Stroma. *Journal of Biological Chemistry*. 2008; **283**: 18573-18581.
- [112] S. Di Paolo, L. Gesualdo, G. Stallone, E. Ranieri, F.P. Schena. Renal expression and urinary concentration of EGF and IL-6 in acutely dysfunctioning kidney transplanted patients. *Nephrology Dialysis Transplantation*. 1997; **12**: 2687-2693.
- [113] A.N. Stein-Oakley, A. Tzanidis, P.J. Fuller, P. Jablonski, N.M. Thomson. Expression and distribution of epidermal growth factor in acute and chronic renal allograft rejection. *Kidney Int*. 1994; **46**: 1207-1215.

- [114] F. Borghese, F.I. Clanchy. CD74: an emerging opportunity as a therapeutic target in cancer and autoimmune disease. *Expert Opinion on Therapeutic Targets*. 2011; **15**: 237-251.
- [115] H.Y. Lan. Role of Macrophage Migration Inhibition Factor in Kidney Disease. *Nephron Experimental Nephrology*. 2008; **109**: e79-e83.
- [116] L. Leng, C.N. Metz, Y. Fang, J. Xu, S. Donnelly, J. Baugh, T. Delohery, Y. Chen, R.A. Mitchell, R. Bucala. MIF Signal Transduction Initiated by Binding to CD74. *The Journal of Experimental Medicine*. 2003; **197**: 1467-1476.
- [117] M. Matsushita, S. Thiel, J.C. Jensenius, I. Terai, T. Fujita. Proteolytic Activities of Two Types of Mannose-Binding Lectin-Associated Serine Protease. *The Journal of Immunology*. 2000; **165**: 2637-2642.
- [118] A. Segarra. Progress in understanding the pathogenesis of IgA nephropathy: New perspectives for the near future? *Nefrologia*. 2010; **30**: 501-507.
- [119] P. Kumar, D. Kodlin, C. Marks, S.H. Leech. Predictive value of serum complement (C3) in renal allograft rejection. *British Journal of Surgery*. 1980; **67**: 500-502.
- [120] S. Tang, W. Zhou, N.S. Sheerin, R.W. Vaughan, S.H. Sacks. Contribution of Renal Secreted Complement C3 to the Circulating Pool in Humans. *The Journal of Immunology*. 1999; **162**: 4336-4341.
- [121] V. Panichi, M. Migliori, S. De Pietro, D. Taccola, B. Andreini, M.R. Metelli, L. Giovannini, R. Palla. The link of biocompatibility to cytokine production. *Kidney Int*. 2000; **58**: S96-S103.
- [122] C. Herzog, R. Seth, S.V. Shah, G.P. Kaushal. Role of mepripin A in renal tubular epithelial cell injury. *Kidney Int*. 2007; **71**: 1009-1018.
- [123] P. Nickerson, J. Jeffery, J. Gough, P. Grimm, R. McKenna, P. Birk, D. Rush. Effect of Increasing Baseline Immunosuppression on the Prevalence of Clinical and Subclinical Rejection: A Pilot Study. *Journal of the American Society of Nephrology*. 1999; **10**: 1801-1805.
- [124] D.N. Rush, S.F. Henry, J.R. Jeffery, T.J. Schroeder, J. Gough. Histological-findings in early routine biopsies of stable renal-allograft recipients. *Transplantation*. 1994; **57**: 208-211.
- [125] E. O'Riordan, T.N. Orlova, V.N. Podust, P.N. Chander, S. Yanagi, M. Nakazato, R. Hu, K. Butt, V. Delaney, M.S. Goligorsky. Characterization of urinary peptide biomarkers of acute rejection in renal allografts. *American Journal of Transplantation*. 2007; **7**: 930-940.

The use of a urinary proteomic shotgun approach to search for potential biomarkers of acute rejections in renal transplant recipients

Loftheim H^{1,2}, Midtvedt K³, Hartmann A³, Reisæter AV³, Falck P², Holdaas H³, Jenssen T³, Reubsaet L¹ and Åsberg A^{2,*}

1: Department of Pharmaceutical Chemistry, School of Pharmacy, University of Oslo, P.O. Box 1068 Blindern, NO-0316 Oslo, Norway.

2: Department of Pharmaceutical Biosciences, School of Pharmacy, University of Oslo, Oslo, Norway

3: Department of Transplant Medicine, Oslo University Hospital-Rikshospitalet, NO-0027 Oslo, Norway.

*Corresponding author:

Professor Anders Åsberg

School of Pharmacy, University of Oslo

P.O.Box. 1068, Blindern

NO-0316 Oslo, NORWAY

E-mail: anders.asberg@farmasi.uio.no

Phone: +47 918 13 624

Fax: +47 22 85 44 02

Running title: Urinary proteomic biomarkers for acute rejection

Key words: Renal transplantation, acute rejection, urinary proteomics, biomarker

Funding sources: The study was entirely funded by internal budgets at the University of Oslo. The authors of this manuscript have no conflicts of interest to disclose as described by the American Journal of Transplantation.

Word count: 200 (abstract), 3904 (abstract and main body), 2 figures and 2 tables.

Abstract

Acute rejection (AR) impairs renal transplant outcome. Currently acute rejections are suspected by a rise in plasma creatinine, and verified by graft biopsy. Identification of non-invasive biomarkers for AR is an unmet clinical need. The urinary proteome is a promising source of relevant biomarkers. From a prospective study, collecting at least weekly urines, we extracted samples from twelve renal transplant recipients to be analyzed. Shotgun proteomics were used to analyze urine from patients experiencing acute rejections (n=6) in a clinical stable phase and at the time of biopsy verified acute rejection. In age-matched control patients not experiencing acute rejection (n=6), analyses were performed at comparable time-points. Eleven up-regulated proteins were associated with AR and they increased several days before biopsy proven AR. These proteins could be grouped by biological function in 2 main groups: Proteins related to growth (IGFBP7, Vasorin, EGF and Galectin-3-binding protein) were significantly up-regulated in the AR-group ($P=0.03$) and proteins related to immune response (MASP2, C3, CD59, Ceruloplasmin, PiGR and CD74) tended to be up-regulated ($P=0.13$). Urinary proteomics provides a robust and sensitive method for identification of predictive biomarkers of AR. Further research is needed to establish the clinical role of this non-invasive method of AR diagnosis.

Introduction

Patients whom experience an acute rejection (AR) after renal transplantation have reduced long-term graft survival and an increased risk of developing chronic allograft nephropathy (1-5). In a clinical setting an AR is typically suspected upon an increase in plasma creatinine that cannot be explained by other plausible causes. Histological examination of renal transplant core biopsies is the current gold standard for diagnosis of a suspected rejection (6). It suffers from sampling heterogeneity and correlates poorly with treatment response and prognosis. The use of plasma creatinine as an indication of acute rejection episodes is flawed by both its relatively late response and low specificity.

Even though renal biopsy *per se* is considered a relatively safe procedure it is time-consuming and invasive (7). In the general follow-up of transplanted patients a non-invasive method with high sensitivity and specificity for diagnosing AR would be a desirable tool. The urinary proteome can be assessed non-invasively and consists of both proteins excreted from plasma (30 %) and locally produced in the kidney (70 %) (8, 9). Inflammation associated with an AR would change the proteome produced in the transplanted kidney and alter the excretion of the proteome from plasma. This makes urine particularly interesting when it comes to identification of potential diagnostic biomarkers for kidney transplant dysfunction. Several attempts have been made to identify possible urinary biomarkers for AR (10-21), but none are used clinically (22, 23). Most of the studies done are hypothesis based and only focus on a few specific target proteins. The development in the field of mass spectrometry has, however, made screening analysis of the full proteome technically possible. This opens for new strategies of biomarker identification in this patient population. Recently, Sigdel et al. used shotgun proteomics to identify proteins in *pooled* urine samples from pediatric kidney transplants with acute rejection (20).

We performed a small prospective pilot study in order to try to identify urinary proteins associated with AR episodes in the early phase following kidney transplantation. Shotgun proteomic analysis of prospectively collected urine samples from each individual utilizing the LTQ-Orbitrap technology was used. In shotgun proteomics proteins are enzymatically digested into peptides which are separated by liquid chromatography coupled to a mass spectrometer. The use of tandem mass spectrometry allows for peptide sequencing which is then used for protein identification by searching against protein databases. Analysis of individual samples gives information on inter-individual variation. Quantification was carried out using stable isotope labeling ($^{18}\text{O}/^{16}\text{O}$) comparing AR and baseline samples.

Materials and methods

Study design and samples

We used urine samples from 6 renal transplant patients with biopsy proven acute rejection (BPAR) and from 6 renal transplant patients with stable graft function, matched for age, immunosuppression and time after transplantation. All urine samples were collected prospectively as part of an at that time ongoing study at Oslo University Hospital (n=20) (24). On average urine samples were available from 4.7 ± 2.7 days after transplantation and the patients were followed for 8-10 weeks. All patients' received induction with i.v. basiliximab on day 0 and 4, cyclosporine A (CsA), mycophenolate mofetil 1 g BID, steroids, sulfacotrimoxazole and proton pump inhibitor. Clinical information, blood and urine samples were collected during the whole period. Urinary samples were collected three times weekly the first two weeks, twice weekly the next four weeks followed by 1-2 samples per week until approximately 10 weeks after transplantation. Acute rejections were suspected in patients based on an increased plasma creatinine of $\geq 20\%$, without other plausible causes, and were verified with a renal core biopsy according to the Banff 97 criteria (6). Urine samples from the day of BPAR were compared with the first available urine sample after transplantation (baseline) and with a sample from a clinically stable phase, approximately one week prior to rejection. Urine samples from the control group were attained at similar time points after transplantation.

The study was performed in accordance with the Declaration of Helsinki and the signed informed consent for the main study covered these urinary proteomics analyses. The study was evaluated by the Regional Committee for Medical Research Ethics, approved by the Norwegian Medicines Agency and registered on www.clinicaltrials.gov (NCT00139009).

Urine sample preparation

Midstream urine were collected several times from each recipient, left at 4 °C for up to one hour, centrifuged at 800 × g for 10 minutes and stored at -70 °C. Further sample preparation of urine was performed as previously described (25). In brief: 5 mL of stored urine was centrifuged at 9000 × g for 10 minutes and applied to Vivaspin 5 kDa cut-off centrifugal filter (Vivascience Sartorius Group, Stonehouse, UK) for desalting and up-concentration of urinary proteins, followed by washing and reconstitution (1200 µL) using 10 mM TrisHCl/150 mM NaCl (pH 7.4). Total protein concentrations in each sample was measured using Bradford's method (26) and the samples from each patient was normalized with respect to total protein content. A volume of 300 µL was transferred to Vivapure Anti-HSA kit (Vivascience Sartorius Group) for albumin depletion. Reduction of the proteins was done using DTT (1 µg per 50 µg protein) at 95 °C for 15 minutes, followed by alkylation with iodoacetic acid (5 µg per 50 µg protein) in the dark at room temperature for 15 min. Tryptic digestion and ¹⁸O/¹⁶O-labeling of the samples was done as described earlier (27). The key parameters were as follows: A sample volume of 50 µL was applied to immobilized trypsin beads and digested using a pH 8.0 buffer at 37 °C for 90 minutes under shaking (1200 rpm). Subsequently, the samples were subjected to ¹⁸O/¹⁶O-labeling using the same beads, but with a different buffer (pH 6.0) at 37 °C for 3 hours under shaking (1200 rpm). Finally, the samples were purified and desalted by using in-house produced C18-tips prior to 2D LC-MS/MS analysis. The AR samples were labeled with ¹⁸O and mixed with both unlabeled baseline samples and unlabeled stable samples (7-11 days prior to rejection) in the AR-group. In the control group, the time matched samples after transplantation was labeled and mixed with unlabeled baseline samples.

2D LC-MS/MS

Two-dimensional LC-MS/MS was used for separation and detection of the tryptic digested peptide mixture. Hydrophilic Interaction Liquid Chromatography (HILIC) was used as the first dimension of separation and was done exactly as described previously (25, 27). Fractions were collected every minute, in total 30 fractions per sample. All fractions were evaporated on a SpeedVac (Thermo) and reconstituted in 60 μ L of 2 % MeCN in 20 mM formic acid.

The nanoLC-MS/MS analysis was done using 20 μ L of reconstituted fractions as primarily as described earlier using an Ultimate 3000 HPLC system (Dionex) coupled to a LTQ-Orbitrap-MS (Thermo, San Jose, CA, USA) (27). The modified HPLC setup in brief: The reconstituted fractions were trapped on a C18 5 mm x 300 μ m id Acclaim PepMap 100 (5 μ m) enrichment column (Dionex). The loading mobile phase was 20 mM formic acid and MeCN (98/2, v/v) delivered at a flow rate of 10 μ L/min for 4 minutes. The sample was transferred to a 150 \times 0.075 mm id Acclaim PepMap 100 (pore size 100 \AA and particle diameter 3 μ m; Dionex) at a flow rate of 300 nL/min (pump flow: 300 μ L/mL, split 1:1000 in flow manager). The mobile phases consisted of A: 20 mM formic acid and MeCN (95/5, v/v) and B: 20 mM formic acid and MeCN (5/95, v/v). A linear gradient was run from 0 % to 50 % B in 60 minutes.

Subsequently, the elution strength was increased to 100 %.

The nanospray ionization (NSI) source was operated in the positive ionization mode using a 360 μ m od \times 20 μ m id distal coated fused silica emitter with a 10 μ m id tip (New Objective, Woburn, MA, USA). Experiments were performed in two scan events: Scan event 1: scan from m/z 300 to m/z 2000 in the FT-Orbitrap with resolution $R = 30000$. Scan event 2: data dependent MS/MS with wide band activation carried out on the highest m/z value for a maximum of one spectrum in the linear ion-trap. The m/z values fragmented were dynamically excluded for 15 sec in order to fragment lower intensity m/z values. Helium gas was used to cause collision-induced fragmentation at 35 % relative collision energy.

Identification and selection of proteins

The acquired mass spectrometric data were analyzed and processed using Proteome Discoverer 1.2 (Thermo) software. The raw files were analyzed in 2 search nodes, where the first search node was a SEQUEST™ (28) search against the FASTA file ipi.HUMAN.v3.76. Carboxymethyl (C) was set as constant modification while oxidation (M) and ¹⁸O (2) on the C-terminal were chosen as variable modifications. The peptide tolerance was set to 10 ppm while MS/MS tolerance was ± 0.8 Da and 2 “missed cleavages” were allowed using trypsin as enzyme. A decoy database search was performed by searching against a database containing the reversed protein sequences with a strict target false discovery rate (FDR) of 0.01 and a relaxed FDR of 0.05. Grouping of proteins were enabled and only the top ranked peptide hits below the FDR threshold (< 0.05) were accepted. In the second search node precursor ions were detected for quantification. The heavy label was set to ¹⁸O (2) on the C-terminal, while the light channel contained no modifications. Only unique peptides were used for quantification and the ratios were normalized against the protein median of the quantified proteins in each patient. The results of the 2 search nodes were merged after processing the data.

For all protein and protein groups: up-regulation was defined as a fold change of ≥ 1 (\log_2) in protein level observed between baseline and AR. This was calculated by \log_2 transforming the actual ¹⁸O/¹⁶O protein ratios (AR/baseline). The list of up-regulated proteins from the study (listed in Table 2) was selected based on several criteria where the first was up-regulation (\log_2 change ≥ 1) from baseline to AR in at least three patients in the rejection group. Further, proteins with higher average ratio in the control group and proteins more frequently up-regulated in the control group were excluded.

Statistics

For the evaluation of the demographic data and comparison of the groups, the Mann-Whitney *U* test was used. A *P*-value of <0.05 was considered statistical significant and all analyses were performed by Minitab version 16.1 (Minitab Inc., Coventry, UK).

Results

Patient demographics

Demographic data of the twelve patients, six with acute rejection and six controls, included in the present analysis are shown in Table 1. The patients in the AR-group experienced biopsy-proven acute rejection episodes on average 42 ± 27 days after transplantation. No significant differences were present between the AR-group and the non-rejection group with respect to recipient age, HLA mismatch or donor age.

Three urine samples from each patient in the AR-group were analyzed; the first available urine sample after transplantation (5.0 ± 3.6 days post transplant, baseline), one sample obtained in a clinically stable phase (7-11 days prior to BPAR) and one at the day of BPAR, obtained prior to biopsying. Two samples from each patient in the control group were analyzed; the first available urine samples post transplant (4.3 ± 1.8 days) and urine from time-points matched to the time of BPAR in the AR-group.

Up-regulated proteins during AR episodes

A total of eleven proteins fulfilled the criteria of a regulated protein (Table 2). Ten of the proteins could be grouped in two main groups by their biological function; proteins involved in regulation of growth and proteins involved in immune responses. One protein, MEP1A, did not fit any of these groups and is presented separately. Figure 1 shows a box plot of the regulated protein groups in the rejection group and in the controls. At the time of BPAR the growth factor proteins were statistically significant up-regulated in the AR-group compared with the control group ($P=0.03$). All patients (except one) in the AR-group were regulated above the predefined threshold. During the same time-interval i.e. at time of BPAR there was

a clear trend towards up-regulation of the immune response proteins in the AR-group as compared with control patients ($P=0.13$). For the immune response protein group, up-regulation was observed in 4 out of 6 patients in the AR-group and in none of the control patients. MEP1A was not detected in any of the control patients but significantly up-regulated in four of the six patients in the AR-group (not detected in the last two patients). Figure 2 shows the log 2 changes in protein levels for the specified protein groups between baseline and the time of BPAR in the AR-group. The trend is that these regulated proteins are up-regulated already in a clinically stable phase, 7-11 days prior to the time of BPAR, when plasma creatinine still is not elevated.

Discussion

The present analysis identifies several up-regulated urinary proteins in association with acute rejection episodes in the early post transplant phase after kidney transplantation. The results demonstrate the applicability of combining shotgun proteomics with quantification by $^{18}\text{O}/^{16}\text{O}$ -labeling in biomarker discovery using sequential samples from several patients. By comparing baseline and event samples in the two groups each patient serve as its own control. This approach, as compared to the more commonly used pooled sample strategy, gives a more informative picture since inter-individual variability can be assessed. The present finding of specific up-regulation of several protein biomarkers in urine may provide a non-invasive and effective way to diagnose acute rejection episodes following renal transplantation.

A very interesting and important finding of this sequential analysis is that the up-regulation was detected already several days prior to the acute rejection was clinically suspected based

on the currently used methods. Any rejection is an on-going process and it is well known that it may take time before a substantial increase in plasma creatinine (>20%) evolves, and an acute rejection is suspected. If the altered urine proteome turns out to be an earlier responding and more specific biomarker of acute rejection it could have dramatic implications on long term outcome of renal transplant recipients. It is possible that only a minor adjustment of the immunosuppressive therapy would be enough to “silence” the early activated immune process, and with this avoid full activation of the immune system. Sequential urine proteomic analysis could possibly also serve as an “*immunometer*” during tapering of the initial high immunosuppressive load after engraftment. In this way it may hence serve as a complimentary tool to standard therapeutic drug monitoring and further improve the individualization of the long-term immunosuppressive regime.

Only the Mannan-binding lectin serin protease 2 (MASP2) was up-regulated in all patients with AR. The extent of regulation of each protein differed individually as showed in Table 2, without any obvious pattern. Grouping the proteins by biological functions substantiated a potentially relevant regulation in the rejection group of the other identified proteins as compared with the control group. There might however be a connection between severity of the acute rejection and the grade of up-regulation of the proteins. In the only patient with arterial changes (Banff 2 A) in the biopsy the regulated urine proteins were almost universally up- regulated, with 10 of the 11 identified proteins elevated at the time of AR (the last was not detected). Analysis of the samples from AR patient 1 (Table 2) which only experienced a borderline rejection further supports this hypothesis as only a relatively low degree of regulation was seen; only 4 of the 11 proteins were up-regulated.

For the proteins related to immune response, a strong up-regulation was observed at the time of rejection in 4 of the patients in the AR-group. The 2 remaining patients, one of the patients

with only a borderline rejection, as mentioned above, actually showed a slight down regulation of these proteins during AR compared to baseline. This was mostly because of a strong down-regulation of acute phase proteins Complement C3 and CD59 glycoprotein in each of these two patients, respectively. CD59 exerts an inhibitory effect on the complement system and inclusion in the immune protein group can be discussed since it counteracts the effect of several of the other proteins. Interestingly, exclusion of CD59 from this protein group results in a significant difference between the AR and control group ($P=0.045$). In the control group most of the patients showed decreased levels of immune proteins compared to baseline, especially for the acute phase proteins where a strong down-regulation was observed in several patients. This is a somewhat different picture than from the proteins involved in growth, where the levels were relatively stable. The proteins categorized in this group are mainly acute phase proteins, but also proteins involved in antigen and immunoglobulin binding.

Earlier studies have shown data which may support a relevant contribution of many of these proteins in acute rejection episodes. For example, the pro-inflammatory cytokine Macrophage migration inhibitory factor (MIF) which is an extracellular ligand for CD74 (29, 30), has been associated with AR in kidney transplants (10). MASP2, polymeric immunoglobulin receptor, Ceruloplasmin and participants in the complement system have also been shown to be regulated in association with acute rejection (20, 31-36).

The proteins involved in cell growth were up-regulated in 5 of 6 patients in the AR-group and are involved in several biological processes relevant to acute rejection episodes. Insulin-like growth factor-binding protein 7 (IGFBP7) modulate effects of vascular endothelial growth factor (VEGF) (37) and is reported to interact with chemokines in high endothelial venules including IFN- γ -inducible protein 10 (IP-10; CXCL10) (38, 39), which has previously been

reported to be elevated in urine in connection with AR (13, 17). Vasorin and Galectin-3-binding protein are closely associated to transforming growth factor-beta (TGF- β_1) and IL-6, both previously linked to acute rejection in this patient population (15, 40-45).

Meprin A subunit alpha (MEP1A protein) did not fit to either of the two protein groups and was only detected in the AR-group. In AR patients the protein levels were significantly higher at the time of AR compared to baseline. Meprins are highly expressed in the brush-border membranes of both kidney and intestine and has been associated with acute kidney injury in mice (46). The absence of identified MEP1A in the control group is an interesting observation and could potentially be very useful in a diagnostic setting. This should however be investigated thoroughly to ensure that the observation is not due to unspecific renal injury or methodological issues. The peptides related to MEP1A were however identified by the proteomic method with a high degree of confidence and all peptides were specific for this protein.

Regarding earlier reports of proteins regulated in urine in association with acute rejections; several of these were also detected in our study but not significantly regulated. When comparing results from pooled samples taken from patients with acute rejection and samples taken from stable patients Sigdel et al. found several up- and down-regulated proteins. They performed further investigations and found a down-regulation of uromodulin and CD44 and up-regulation of SERPINF1 (20). Data from the present study of individual samples suggest a high degree of between patient variability in the regulation of uromodulin in the rejection group, showing highly elevated protein levels in 3 patients and a decrease in concentration in 2 of the patients. SERPINF1 did not show any clear regulation pattern while CD44 was slightly increased during AR in 4 patients, but the increase was less than twofold in all except one patient i.e. not enough to serve as a reliable rejection marker according to our criteria.

Another study identified β -defensin-1 and α -1-antichymotrypsin as regulated during acute rejection (47). Our data also supports this to some extent. No obvious increase was, however, observed during rejection in the AR-group, but a distinct decrease was seen in the control group indicating a potential regulation of α -1-antichymotrypsin, even though it did not fulfill our predefined criteria for regulation. In addition, other proteins have been investigated using a more targeted approach (e.g. ELISA) but these were not confirmed by our investigation (10-19, 21). However, several of these proteins (e.g. MIF, IP-10 and IL-6) are physiologically associated with the up-regulated proteins identified in the present study.

A major strength of our analysis is that each patient was his or her own control, comparing the protein levels during AR with the levels at periods without rejection. In addition individual samples were analyzed in the present study, not pooled urine. This provides more detailed information of the protein regulation in association with an acute rejection. All identified proteins are also physiological plausible to be involved in an acute rejection episode, further substantiating our findings. Since we investigated sequential samples it was possible to identify that the activation of these proteins were present already several days before clinical suspicion of the acute rejections were present. A limitation of the present study is the lack of urine analysis after treatment of the acute rejection episodes. Logically, a urinary biomarker of potential diagnostic value should return to baseline level as the acute rejection episode is successfully reversed. Unfortunately, relevant urines for such analyses were not collected in the present trial. It should also be pointed out that the control group patients were not verified non-rejectors by protocol biopsies. Previous studies have shown an incidence of almost 30 % subclinical rejections in apparently stable patients treated with CsA (48, 49). It is hence possible that sub-clinical rejections could be present in some of the control patients. This would affect the protein regulation in this patient group, making the

interpretation somewhat biased. In addition, the present analysis only includes a very restricted number of patients. Further prospective studies are therefore needed in larger populations, where biopsies also are performed in the control patients, in order to elucidate on the involvement of these proteins in acute rejection and their potential usability as diagnostic biomarkers.

In conclusion, this study shows the applicability of shotgun proteomics in combination with quantification by $^{18}\text{O}/^{16}\text{O}$ -labeling in biomarker discovery in sequential urine samples. Two groups of physiological related proteins with relevance to immunological processes during acute rejection episodes were found to be elevated in patients with BPAR compared to controls. The use of urine and a trend towards an increase of proteins levels prior to deterioration of graft function potentially opens for early, specific and non-invasive detection of acute rejection episodes. Prevention of acute rejections, rather than cure, could dramatically improve long term graft survival.

Disclosure

The study was entirely funded by internal budgets at the University of Oslo. The authors of this manuscript have no conflicts of interest to disclose as described by the American Journal of Transplantation.

Tables

	All	No-rejection group	Rejection group	<i>P</i> value
Gender (male/female)	7/5	3/3	4/2	
Weight (kg)	75.7±10.2	80.2±11.1	71.3±7.7	0.09
Age (years)	55.0±12.2	59.5±5.4	50.5±15.8	0.26
HLA mismatch (A + B)	1.2±0.9	1.0±1.1	1.3±0.8	0.47
HLA mismatch (DR)	1.2±0.7	1.2±0.8	1.2±0.8	1.00
HLA mismatch (DQ)	0.5±0.5	0.4±0.5	0.5±0.5	0.86
Serum creatinine*	143±48	119±55	168±24	0.07
Age donor (years)	51.5±10.8	49.0±14.8	54.0±4.6	0.52
Deceased donor (n)	11/12	6/6	5/6	

Data are means±SD

*at time of BPAR and matched time-points, respectively

Table 2. Up-regulated proteins¹ in AR/control urine samples compared to baseline shown for individual patients.

IPI ID	Gene ID	Protein name	Rejection group						No-rejection group					
			AR1	AR2	AR3	AR4	AR5	AR6	C1	C2	C3	C4	C5	C6
Immune proteins														
IP100217775.1	CD74	Isoform 2 of HLA class II histocompatibility antigen gamma chain	ND ¹	0.47	2.57	4.06	1.81	1.23	0.39	1.03	0.81	0.99	2.10	0.58
IP100004573.2	PIGR	Polymeric immunoglobulin receptor	-0.04	0.66	2.27	1.31	0.36	2.20	0.29	0.63	0.71	1.65	0.19	0.14
IP100783987.2	C3	Complement C3 (Fragment)	-0.17	3.17	-0.48	1.25	-5.32	2.64	-3.49	ND	1.14	-4.80	-1.54	-3.63
IP100017601.1	CP	Ceruloplasmin	0.42	4.40	0.34	1.15	ND	4.79	-1.87	-1.25	0.22	-1.02	0.53	-2.02
IP100306378.5	MASP2	Isoform 2 of Mannan-binding lectin serine protease 2	1.10	1.88	1.36	2.30	1.26	4.06	0.57	-3.94	1.94	1.19	2.44	0.43
IP100011302.1	CD59	CD59 glycoprotein	-2.65	1.16	1.30	1.74	0.40	3.62	-1.52	2.68	-1.90	1.73	1.31	0.19
Growth factors														
IP100016915.1	IGFBP7	Insulin-like growth factor-binding protein 7	0.11	-0.43	2.40	1.01	-0.91	2.84	0.71	1.42	0.05	0.58	-0.02	ND
IP100966866.1	EGF	Epidermal growth factor	1.71	3.49	2.15	0.75	0.97	ND	0.79	ND	ND	1.51	0.51	0.13
IP100395488.2	VASN	Vasorin	1.27	1.11	ND	0.61	0.05	2.10	0.96	-2.27	2.00	0.66	1.69	-0.81
IP100023673.1	LGALS3BP	Galectin-3-binding protein	1.01	0.20	2.62	1.76	0.61	3.59	0.26	1.21	0.03	1.15	0.32	0.30
Other														
IP100004372.3	MEP1A	MEP1A protein (Meprin A subunit alpha)	ND	ND	1.87	2.87	1.31	1.02	ND	ND	ND	ND	ND	ND

¹ Criteria for up-regulation: up-regulation (log₂ change ≥ 1) from baseline to AR in at least three patients in the AR-group. Proteins with higher average ratio in the control group and proteins more frequently up-regulated in the control group were excluded.

² ND: Not detected

Legend to figures

Figure 1. Box plot showing fold change (\log_2) of immune proteins, growth factors and MEP1A from baseline to acute rejection in the AR-group compared with the control group.

Figure 2. Fold change (\log_2) of immune proteins, growth factors and MEP1A in the rejection group, AR1 (●) AR2 (×) AR3 (◆) AR4 (+) AR5 (■) AR6 (▲), from baseline to Biopsy Proven Acute Rejection (BPAR). The center point (Clinically stable) is 7-11 days before BPAR, at stable serum creatinine levels.

Figures

Figure 1

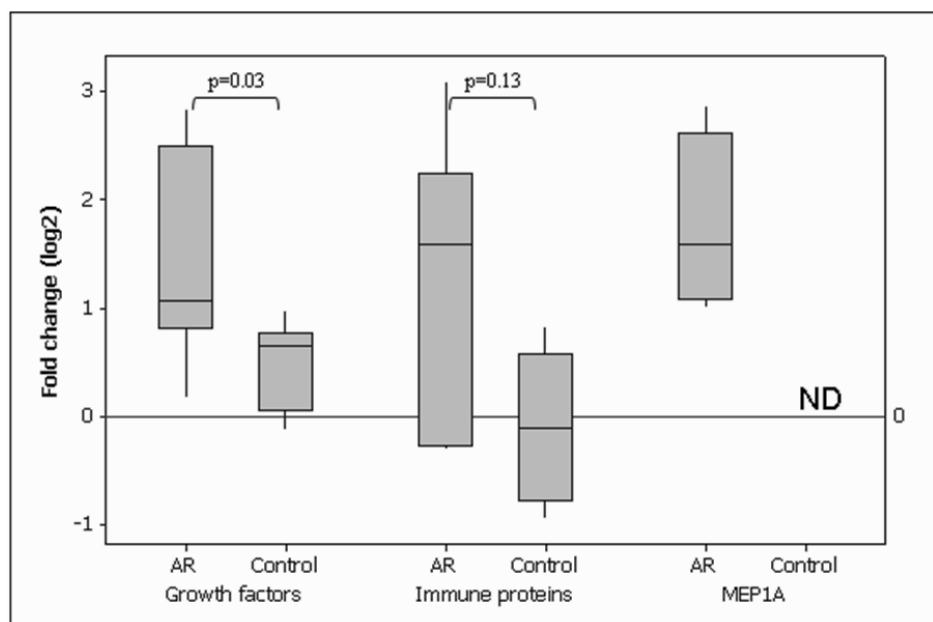
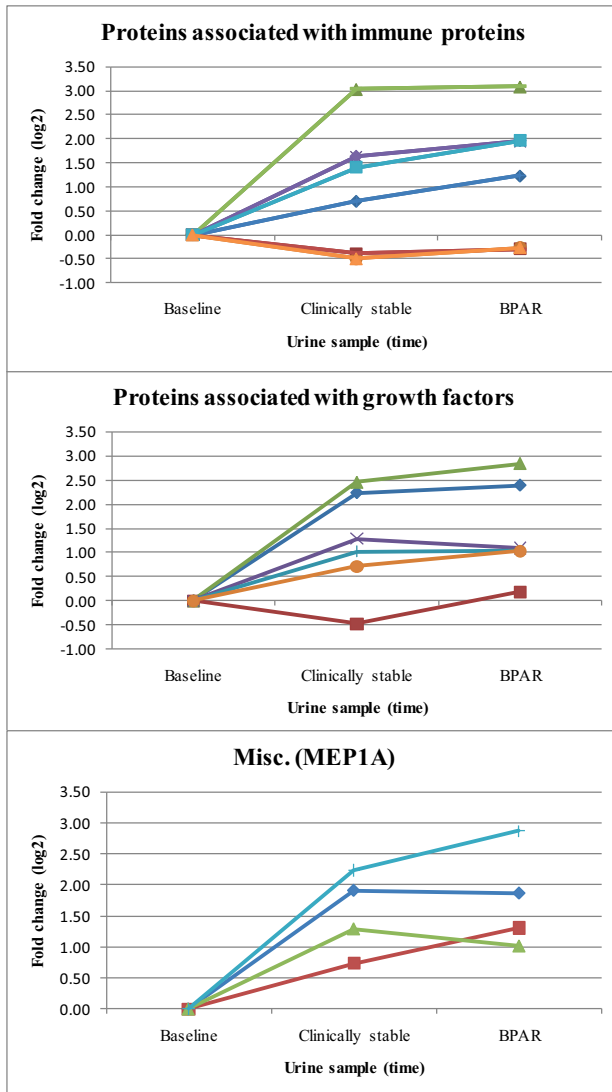

Figure 2



References

1. Almond PS, Matas A, Gillingham K, Dunn DL, Payne WD, Gores P, et al. Risk-Factors for Chronic Rejection in Renal-Allograft Recipients. *Transplantation* 1993;55(4):752-757.
2. Hariharan S, Johnson CP, Bresnahan BA, Taranto SE, McIntosh MJ, Stablein D. Improved Graft Survival after Renal Transplantation in the United States, 1988 to 1996. *N Engl J Med* 2000;342(9):605-612.
3. Kaplan B. Overcoming barriers to long-term graft survival. *Am J Kidney Dis* 2006;47(4):S52-S64.
4. Meier-Kriesche HU, Ojo AO, Hanson JA, Cibrik DM, Pugh JD, Leichtman AB, et al. Increased impact of acute rejection on chronic allograft failure in recent era. *Transplantation* 2000;70(7):1098-1100.
5. Nankivell BJ, Chapman JR. Chronic allograft nephropathy: current concepts and future directions. *Transplantation* 2006;81(5):643-654.
6. Racusen LC, Solez K, Colvin RB, Bonsib SM, Castro MC, Cavallo T, et al. The Banff 97 working classification of renal allograft pathology. *Kidney Int* 1999;55(2):713-723.
7. Reichelt O, Müller J, von Eggeling F, Driesch D, Wunderlich H, Schubert J, et al. Prediction of renal allograft rejection by urinary protein analysis using ProteinChip Arrays (surface-enhanced laser desorption/ionization time-of-flight mass spectrometry). *Urology* 2006;67(3):472-475.
8. Pieper R, Gatlin CL, McGrath AM, Makusky AJ, Mondal M, Seonarain M, et al. Characterization of the human urinary proteome: A method for high-resolution

- display of urinary proteins on two-dimensional electrophoresis gels with a yield of nearly 1400 distinct protein spots. *Proteomics* 2004;4(4):1159-1174.
9. Thongboonkerd V. Recent progress in urinary proteomics. *Proteomics: Clin Appl* 2007;1(8):780-791.
 10. Brown FG, Nikolic-Paterson DJ, Chadban SJ, Dowling J, Jose M, Metz CN, et al. Urine macrophage migration inhibitory factor concentrations as a diagnostic tool in human renal allograft rejection. *Transplantation* 2001;71(12):1777-1783.
 11. Donadio C, Puccini R, Lucchesi A, Giordani R, Rizzo G. Urinary excretion of proteins and tubular enzymes in renal transplant patients. *Ren Fail* 1998;20(5):707-715.
 12. Gupta RK, Jain M, Sharma RK. Serum & urinary interleukin-2 levels as predictors in acute renal allograft rejection. *Indian J Med Res* 2004;119:24-27.
 13. Hauser IA, Spiegler S, Kiss E, Gauer S, Sichler O, Scheuermann EH, et al. Prediction of Acute Renal Allograft Rejection by Urinary Monokine Induced by IFN- γ (MIG). *J Am Soc Nephrol* 2005;16(6):1849-1858.
 14. Hu H, Aizenstein BD, Puchalski A, Burmania JA, Hamawy MM, Knechtle SJ. Elevation of CXCR3-Binding Chemokines in Urine Indicates Acute Renal-Allograft Dysfunction. *Am J Transplant* 2004;4(3):432-437.
 15. Kaden J, Priesterjahn R. Increasing urinary IL-6 levels announce kidney graft rejection. *Transpl Int* 2000;13(0):S34-S41.
 16. Lederer SR, Friedrich N, Regenbogen C, Getto R, Toepfer M, Sitter T. Non-Invasive Monitoring of Renal Transplant Recipients: Urinary Excretion of Soluble Adhesion Molecules and of the Complement-Split Product C4d. *Nephron Clin Pract* 2003;94(1):c19-c26.

17. Matz M, Beyer J, Wunsch D, Mashreghi MF, Seiler M, Pratschke J, et al. Early post-transplant urinary IP-10 expression after kidney transplantation is predictive of short- and long-term graft function. *Kidney Int* 2006;69(9):1683-1690.
18. Oetting WS, Rogers TB, Krick TP, Matas AJ, Ibrahim HN. Urinary beta(2)-microglobulin is associated with acute renal allograft rejection. *Am J Kidney Dis* 2006;47(5):898-904.
19. Roelofs JJTH, Rowshani AT, Van Den Berg JG, Claessen N, Aten J, Ten Berge IJM, et al. Expression of urokinase plasminogen activator and its receptor during acute renal allograft rejection. *Kidney Int* 2003;64(5):1845-1853.
20. Sigdel TK, Kaushal A, Gritsenko M, Norbeck AD, Qian W-J, Xiao W, et al. Shotgun proteomics identifies proteins specific for acute renal transplant rejection. *Proteomics: Clin Appl* 2010;4(1):32-47.
21. Teppo AM, von Willebrand E, Honkanen E, Ahonen J, Gronhagen-Riska C. Soluble intercellular adhesion molecule-1 (sICAM-1) after kidney transplantation: The origin and role of urinary sICAM-1? *Transplantation* 2001;71(8):1113-1119.
22. Gwinner W. Renal transplant rejection markers. *World J Urol* 2007;25(5):445-455.
23. Thongboonkerd V, Malasit P. Renal and urinary proteomics: Current applications and challenges. *Proteomics* 2005;5(4):1033-1042.
24. Falck P, Asberg A, Guldseth H, Bremer S, Akhlaghi F, Reubsæet JLE, et al. Declining intracellular T-lymphocyte concentration of cyclosporine precedes acute rejection in kidney transplant recipients. *Transplantation* 2008;85(2):179-184.
25. Loftheim H, Nguyen TD, Malerød H, Lundanes E, Åsberg A, Reubsæet L. 2-D hydrophilic interaction liquid chromatography-RP separation in urinary proteomics - Minimizing variability through improved downstream workflow compatibility. *J Sep Sci* 2010;33(6-7):864-872.

26. Bradford MM. Rapid and Sensitive Method for Quantitation of Microgram Quantities of Protein Utilizing Principle of Protein-Dye Binding. *Anal Biochem* 1976;72(1-2):248-254.
27. Loftheim H, Åsberg A, Reubsaet L. Accelerated 18O-labeling in urinary proteomics. *J Chromatogr A* 2010;1217(52):8241-8248.
28. Eng JK, McCormack AL, Yates JR. An Approach to Correlate Tandem Mass-Spectral Data of Peptides with Amino-Acid-Sequences in a Protein Database. *J Am Soc Mass Spectrom* 1994;5(11):976-989.
29. Leng L, Metz CN, Fang Y, Xu J, Donnelly S, Baugh J, et al. MIF Signal Transduction Initiated by Binding to CD74. *J Exp Med* 2003;197(11):1467-1476.
30. Lan HY. Role of Macrophage Migration Inhibition Factor in Kidney Disease. *Nephron Exp Nephrol* 2008;109(3):e79-e83.
31. Borghese F, Clanchy FI. CD74: an emerging opportunity as a therapeutic target in cancer and autoimmune disease. *Expert Opin Ther Targets* 2011;15(3):237-251.
32. Kumar P, Kodlin D, Marks C, Leech SH. Predictive value of serum complement (C3) in renal allograft rejection. *Br J Surg* 1980;67(7):500-502.
33. Tang S, Zhou W, Sheerin NS, Vaughan RW, Sacks SH. Contribution of Renal Secreted Complement C3 to the Circulating Pool in Humans. *J Immunol* 1999;162(7):4336-4341.
34. Segarra A. Progress in understanding the pathogenesis of IgA nephropathy: New perspectives for the near future? *Nefrologia* 2010;30(5):501-507.
35. Panichi V, Migliori M, De Pietro S, Taccola D, Andreini B, Metelli MR, et al. The link of biocompatibility to cytokine production. *Kidney Int* 2000;58(S76):S96-S103.

36. Matsushita M, Thiel S, Jensenius JC, Terai I, Fujita T. Proteolytic Activities of Two Types of Mannose-Binding Lectin-Associated Serine Protease. *J Immunol* 2000;165(5):2637-2642.
37. Tamura K, Hashimoto K, Suzuki K, Yoshie M, Kutsukake M, Sakurai T. Insulin-like growth factor binding protein-7 (IGFBP7) blocks vascular endothelial cell growth factor (VEGF)-induced angiogenesis in human vascular endothelial cells. *Eur J Pharmacol* 2009;610(1-3):61-67.
38. Nagakubo D, Murai T, Tanaka T, Usui T, Matsumoto M, Sekiguchi K, et al. A High Endothelial Venule Secretory Protein, Mac25/Angiomodulin, Interacts with Multiple High Endothelial Venule-Associated Molecules Including Chemokines. *J Immunol* 2003;171(2):553-561.
39. Usui T, Murai T, Tanaka T, Yamaguchi K, Nagakubo D, Lee CM, et al. Characterization of mac25/angiomodulin expression by high endothelial venule cells in lymphoid tissues and its identification as an inducible marker for activated endothelial cells. *Int Immunol* 2002;14(11):1273-1282.
40. Campistol JM, Iñigo P, Larios S, Bescos M, Oppenheimer F. Role of transforming growth factor- β 1 in the progression of chronic allograft nephropathy. *Nephrol Dial Transplant* 2001;16(suppl 1):114-116.
41. Ikeda Y, Imai Y, Kumagai H, Nosaka T, Morikawa Y, Hisaoka T, et al. Vasin, a transforming growth factor β -binding protein expressed in vascular smooth muscle cells, modulates the arterial response to injury in vivo. *Proc Natl Acad Sci U S A* 2004;101(29):10732-10737.
42. Shihab FS, Tanner AM, Shao Y, Weffer MI. Expression of TGF- β 1 and matrix proteins is elevated in rats with chronic rejection. *Kidney Int* 1996;50(6):1904-1913.

43. Fukaya Y, Shimada H, Wang L-C, Zandi E, DeClerck YA. Identification of Galectin-3-binding Protein as a Factor Secreted by Tumor Cells That Stimulates Interleukin-6 Expression in the Bone Marrow Stroma. *J Biol Chem* 2008;283(27):18573-18581.
44. Ullrich A, Sures I, D'Egidio M, Jallal B, Powell TJ, Herbst R, et al. The secreted tumor-associated antigen 90K is a potent immune stimulator. *J Biol Chem* 1994;269(28):18401-18407.
45. Di Paolo S, Gesualdo L, Stallone G, Ranieri E, Schena FP. Renal expression and urinary concentration of EGF and IL-6 in acutely dysfunctioning kidney transplanted patients. *Nephrol Dial Transplant* 1997;12(12):2687-2693.
46. Herzog C, Seth R, Shah SV, Kaushal GP. Role of meprin A in renal tubular epithelial cell injury. *Kidney Int* 2007;71(10):1009-1018.
47. O'Riordan E, Orlova TN, Podust VN, Chander PN, Yanagi S, Nakazato M, et al. Characterization of urinary peptide biomarkers of acute rejection in renal allografts. *Am J Transplant* 2007;7(4):930-940.
48. Nickerson P, Jeffery J, Gough J, Grimm P, Mckenna R, Birk P, et al. Effect of Increasing Baseline Immunosuppression on the Prevalence of Clinical and Subclinical Rejection: A Pilot Study. *J Am Soc Nephrol* 1999;10(8):1801-1805.
49. Rush DN, Henry SF, Jeffery JR, Schroeder TJ, Gough J. Histological-findings in early routine biopsies of stable renal-allograft recipients. *Transplantation* 1994;57(2):208-211.

