

Secure Communication and Implementation for a Chaotic Autonomous System

Li Feng Zhang

Faculty of Geomatics, Lanzhou Jiaotong University
Lanzhou, 730070, Gansu Province, China
e-mail: zhanglf@mail.lzjtu.cn

Abstract

In this paper, a three-dimensional chaotic autonomous system is presented. The stability of the equilibrium and the conditions of the Hopf bifurcation are studied by means of nonlinear dynamics theory. Then, the circuit of chaotic system is structured out in Multisim platform by the unit circuit. The chaotic system is applied to secure communications by linear feedback synchronization control. All simulations results performed on three-dimensional chaotic autonomous system are verified the applicable of secure communication.

Keywords: chaotic system, Hopf bifurcation, linear feedback synchronization, secure communication

Copyright © 2014 Institute of Advanced Engineering and Science. All rights reserved.

1. Introduction

Since Lorenz find the first chaotic systems-Lorenz system in 1963, many new chaotic systems have been presented and studied widely, and these attractors of systems have been also verified by the experimental circuit [1-5]. There are many example, such as Chen, and Liu systems that have been widely studied. Literature [6] report a new Lorenz-like chaotic system that there are six terms on the right-hand side but only relies on two quadratic nonlinearities xz and xy . Its nonlinear characteristic and basic dynamic properties are studied, and nonlinear circuit is also structured out. Stouboulos study a chaotic dynamics of a fourth-order autonomous nonlinear electric circuit that consists of one linear negative conductance and one symmetrical piecewiselinear $v-i$ characteristic and two capacitances C_1 and C_2 [7]. Mada designed and simulate a non-autonomous fourth order chaotic oscillator circuit that is addressed suitable for chaotic masking communication circuit using Matlab and Multisim programs [8].

Literature [9-12] achieves the effective control of different nonlinear circuit through adding electronic components and external incentive. In recent years, secure communication that base on chaos and chaotic synchronization has always been a hot spot of the study, however, information effective masking that is realized by physical method is a difficulty.

The stability of the equilibrium and the conditions of the Hopf bifurcation are studied by means of nonlinear dynamics theory. Then, the new system is controlled through linear feedback synchronization control, and secure communication circuit based on chaotic system is structured out.

2. Mathematical Model of the Chaotic Attractor

The chaotic system is given by:

$$\begin{cases} \dot{x} = a(y - x) \\ \dot{y} = abx - axz \\ \dot{z} = xy - (a + c)z \end{cases} \quad (1)$$

where $x = (x, y, z)^T \in \mathbf{R}^3$ is the state variables of the system, $a, b, c \in \mathbf{R}$ are constants. There are six terms on the right-hand side but only relies on two quadratic nonlinearities xz and xy .

The system exits a chaotic attractor for the parameter value $a = 5, b = 4, c = -4$, as shown in Figure 1. Figure 1 (a) shows the trajectory of the system plotted in \mathbb{R}^3 , and Figure 1(b)-(d) show the projections of the phase space orbit onto the x-y plane, the x-z plane and the y-z plane, respectively. Figure 1 (e) shows three Lyapunov exponents of the chaotic attractor for the parameter value $a = 5, b = 4, c = -4$. It is hard to fully appreciate the intricacy of this three-dimensional trajectory from Figure 1. A movie of these figures would be much better.

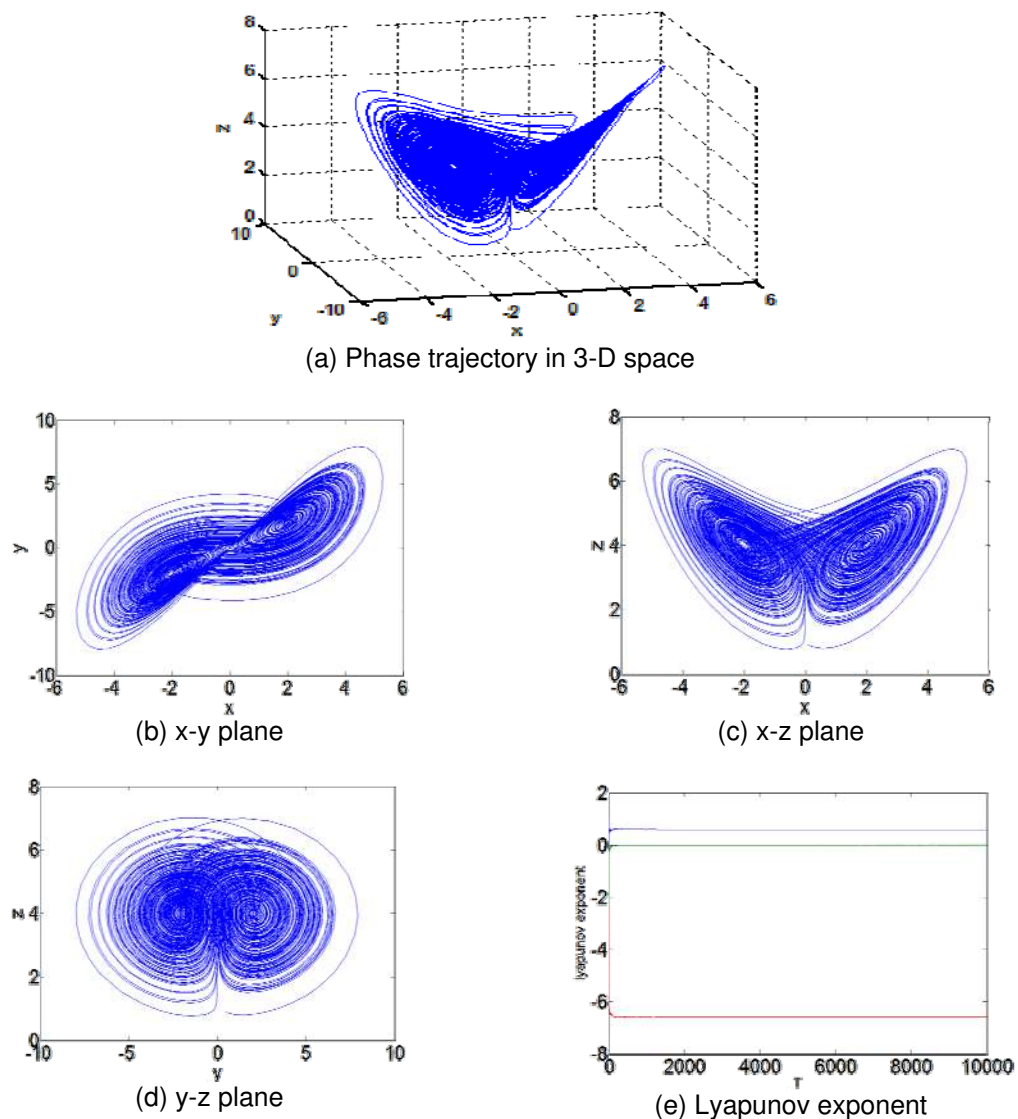

Figure 1. Numerical simulation for a chaotic attractor of system (1)

3. The Stability and the Bifurcation of the Equilibrium

We now turn to analyzing the fixed points of the new system. The equilibrium satisfy

$$\begin{cases} a(y - x) = 0 \\ abx - axz = 0 \\ xy - (a + c)z = 0 \end{cases} .$$

Therefore, system (1) has three equilibrium if $b(a+c) > 0$:

$$S_1(0,0,0), S_2(\sqrt{b(a+c)}, \sqrt{b(a+c)}, b), S_3(-\sqrt{b(a+c)}, -\sqrt{b(a+c)}, b).$$

Proposition 1 If $2a+c > 0, a^2+ac-a^2b < 0$ or $-ba^2(a+c) < 0$, then the equilibrium S_1 is unstable.

Proof The Jacobian matrix of system (1) at S_1 is

$$A = \begin{bmatrix} -a & a & 0 \\ ab & 0 & 0 \\ 0 & 0 & -(a+c) \end{bmatrix} \quad (2)$$

and the characteristic equation is

$$p(\lambda) = \lambda^3 + (2a+c)\lambda^2 + (a^2 - a^2b + ac)\lambda - ba^2(a+c) \quad (3)$$

According to Routh-Hurwitz criterion, if and only if

$$2a+c > 0, a^2+ac-a^2b < 0 \text{ or } -ba^2(a+c) < 0. \quad (4)$$

Then the equilibrium S_1 is unstable.

Proposition 2 Eq.(3) has a negative real $\lambda_3 = -(2a+c)$ together with a pair of conjugate purely

imaginary roots $\lambda_{1,2} = \pm i \sqrt{a^2 - (\frac{2}{3}a - \frac{1}{3}c)(a+c) + ac}$, and $\left. \frac{d \operatorname{Re} \lambda}{db} \right|_{b=b_0} \neq 0$, therefore system

(1) displays a Hopf bifurcation at the point S_1 if $a \neq 0, 2a+c > 0, a^2 - (\frac{2}{3}a - \frac{1}{3}c)(a+c) + ac > 0$.

Proof Let $\lambda = i\omega_0$ ($\omega_0 > 0$) be a root of (3), we have

$$\omega_0 = \sqrt{a^2 - (\frac{2}{3}a - \frac{1}{3}c)(a+c) + ac}, \quad b_0 = \frac{2a-c}{3a^2(a+c)} \quad (5)$$

and the three characteristic roots are as follows

$$\lambda_{1,2} = \pm i\omega_0, \quad \lambda_3 = -(2a+c) \quad (6)$$

Differentiating both sides of Eq. (3) with respect to b , we obtain

$$\left. \frac{d \operatorname{Re} \lambda}{db} \right|_{b=b_0} = \frac{3a^3}{26a^2 + 28ac + 8c^2} \neq 0. \quad (7)$$

4. Bifurcation and Chaotic Analysis of the System

For this system, bifurcation can easily be detected by examining graphs of z versus each of the control parameters a, b, c respectively if we fix the other two.

When the parameters $b = 4, c = -4$, while a is varied on the closed interval $[4.1, 4.5]$. Fig.2 shows the bifurcation diagram of state y and the Lyapunov-exponent spectrum versus increasing a , respectively. It can be observed that the bifurcation diagram well coincides with the Lyapunov-exponent spectrum. Along with the increase of parameters a , the system (1) comes into chaos after the period-doubling bifurcation has occurred many times, and the periodic windows also contain the period-doubling bifurcation in chaotic areas.

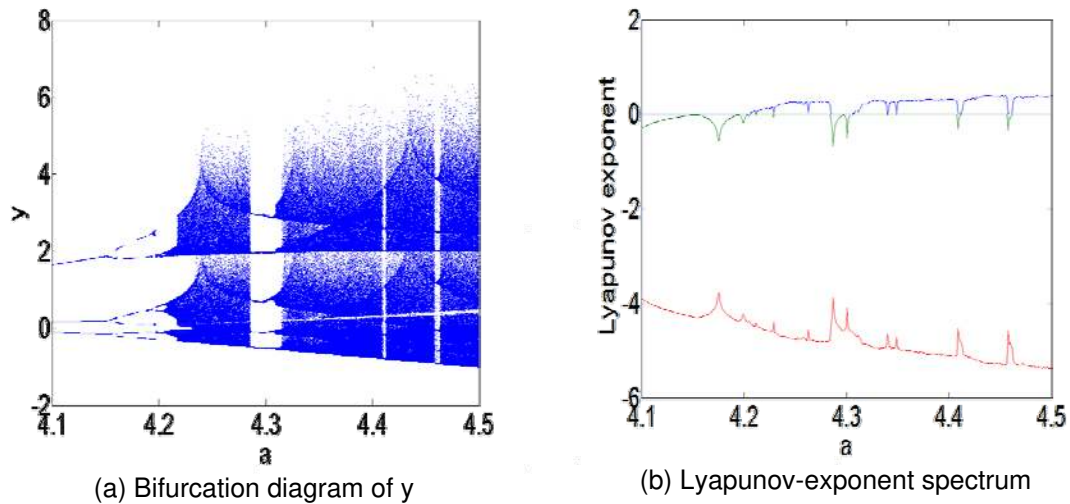

Figure 2. Bifurcation diagram and Lyapunov-exponent spectrum for specific values set ($b = 4, c = -4$) vs the control parameter a .

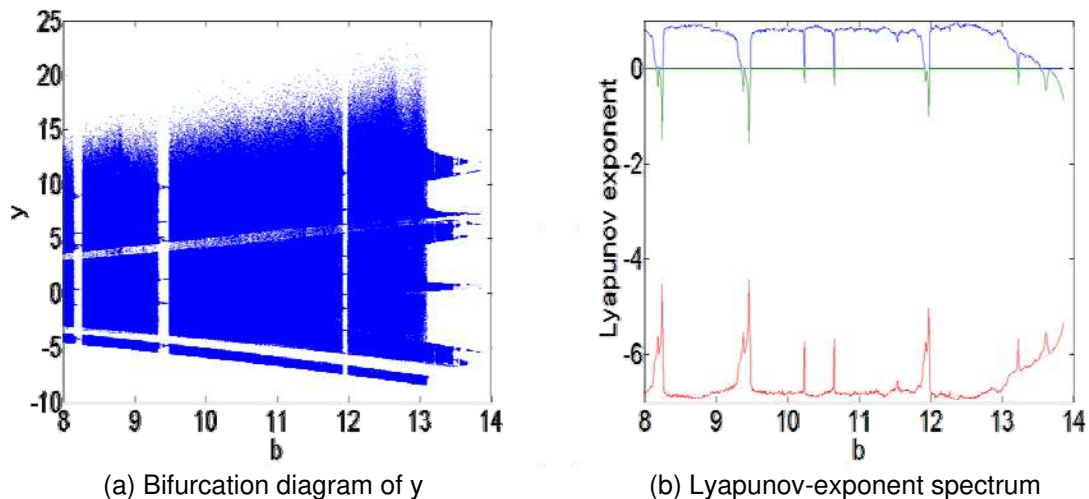

Figure 3. Bifurcation diagram and Lyapunov-exponent spectrum for specific values set ($a = 5, c = -4$) vs. the control parameter b .

When the parameters $a = 5, c = -4$ are fixed, while b is varied on the closed interval $[8, 14]$. Figure 3 shows the bifurcation diagram of the state y and the corresponding Lyapunov-exponent spectrum versus increasing b , respectively. While b increasing, the system is undergoing some representative dynamical routes. The system (1) come into chaos that contain

multiple periodic windows versus increasing b , and inverse period-doubling bifurcation phenomenon emerge from every periodic window.

5. Circuit Simulation of System (1)

Through the above analysis, system (1) has abundant dynamic behavior, which has great application value in the information transmission, detection and treatment. In order to get the chaotic signal, electronic circuit of system (1) is designed by the principle of electronic circuit design for the parameter value $a = 5, b = 4, c = -4$, as shown in Figure 4. Figure 5 also shows Multisim simulation results of this circuit. The operational amplifiers and associated circuitry perform the basic operations of addition, subtraction, and integration. The nonlinear terms in the equation are implemented with the analog multipliers AD633. The occurrence of the chaotic attractor can be clearly seen from Figure 5(a)-(c). By compared with Figure 1(b)-(d), it can be concluded that a good qualitative agreement between the numerical simulation and the experimental realization is obtained.

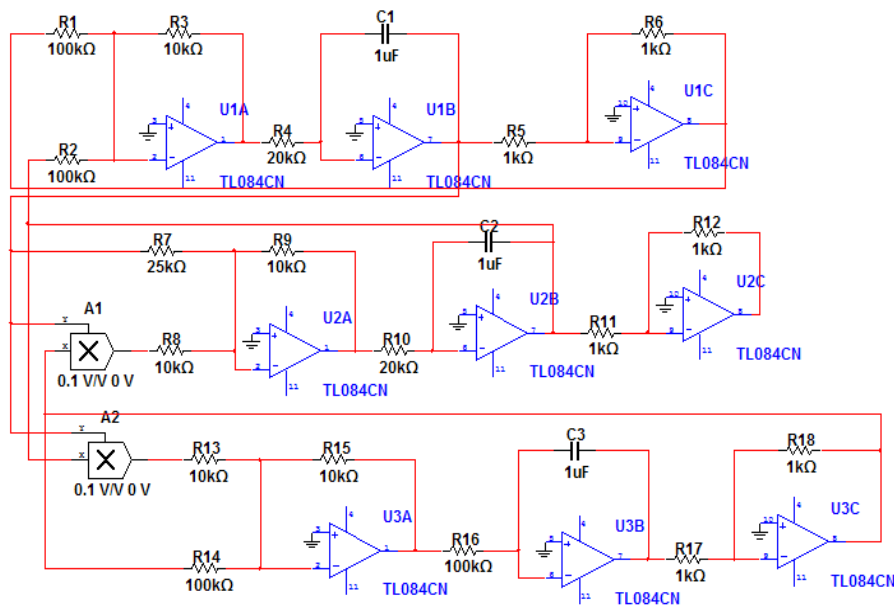

Figure 4. Circuit diagram for realizing the chaotic attractor of system and the values of electronic elements

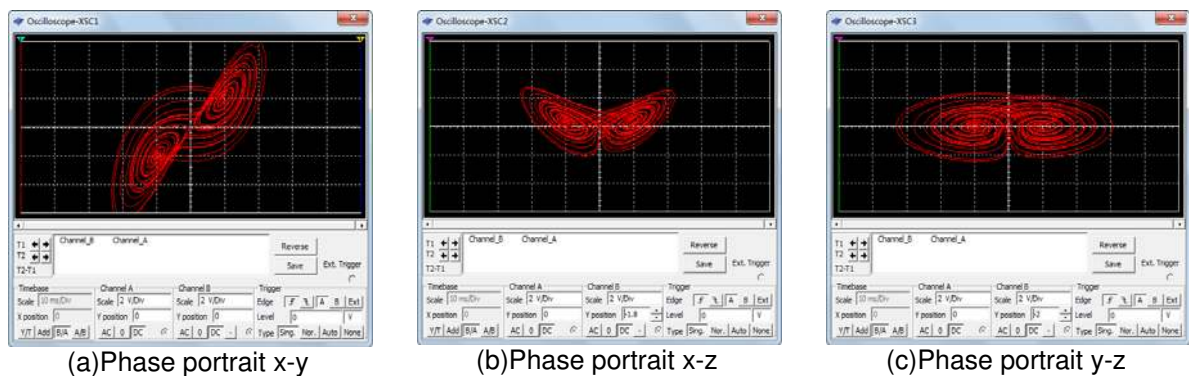

Figure 5. Experimental observations of the chaotic attractor in different planes

6. Linear Feedback Synchronization and Application for Secure Communication

Synchronization between chaotic systems has received considerable attention and led to communication applications. Synchronization of chaotic motions among coupled dynamical systems is an important generalization from the phenomenon of the synchronization of linear system, which is useful and indispensable in communications. However, some other important factors need to be considered in order to build secure communications system.

The new system is controlled through linear feedback synchronization control, and linear coupling constant $k=1.5$. The controlled system that base on linear feedback synchronization can be described by:

$$\begin{cases} \dot{x}_1 = a(y_1 - x_1) \\ \dot{y}_1 = abx_1 - ax_1z_1 \\ \dot{z}_1 = x_1y_1 - (a+c)z_1 \\ \dot{x}_2 = a(y_2 - x_2) + k(x_1 - x_2) \\ \dot{y}_2 = abx_2 - ax_2z_2 + k(y_1 - y_2) \\ \dot{z}_2 = x_2y_2 - (a+c)z_2 + k(z_1 - z_2) \end{cases} \quad (8)$$

where k is linear coupling constant.

The corresponding circuit equation can be described by

$$\begin{cases} \dot{x}_1 = \frac{R_3}{R_1R_4C_1}(y_1 - x_1) \\ \dot{y}_1 = \frac{R_9}{R_7R_{10}C_2}x_1 - \frac{R_9}{10R_8R_{10}C_2}x_1z_1 \\ \dot{z}_1 = \frac{R_{15}}{10R_{13}R_{16}C_3}x_1y_1 - \frac{R_{15}}{R_{14}R_{16}C_3}z_1 \\ \dot{x}_2 = \frac{R_{21}}{R_{19}R_{22}C_4}(y_2 - x_2) + \frac{R_{21}}{R_{22}R_{40}C_4}(x_1 - x_2) \\ \dot{y}_2 = \frac{R_{27}}{R_{25}R_{28}C_5}x_2 - \frac{R_{27}}{10R_{26}R_{28}C_5}x_2z_2 + \frac{R_{27}}{R_{28}R_{44}C_5}(y_1 - y_2) \\ \dot{z}_2 = \frac{R_{31}}{10R_{29}R_{32}C_6}x_2y_2 - \frac{R_{31}}{R_{30}R_{32}C_6}z_2 + \frac{R_{31}}{R_{32}R_{48}C_6}(z_1 - z_2) \end{cases} \quad (9)$$

The circuit parameters of system (8) are

$$\begin{aligned} R_1 = R_2 = R_{14} = R_{16} = R_{19} = R_{20} = R_{30} = R_{32} = 100k\Omega, R_3 = R_8 = R_9 = R_{13} = R_{15} = R_{21} = R_{26} = \\ R_{27} = R_{29} = R_{31} = 10k\Omega, R_4 = R_{10} = R_{22} = R_{28} = 20k\Omega, R_7 = R_{25} = 25k\Omega, R_5 = R_6 = R_{11} = R_{12} = \\ R_{17} = R_{18} = R_{23} = R_{24} = R_{33} = R_{34} = R_{35} = R_{36} = R_{37} = R_{38} = R_{39} = R_{41} = R_{42} = R_{43} = R_{45} = R_{46} = \\ R_{47} = 1k\Omega, R_{40} = R_{44} = 333.33k\Omega, R_{48} = 66.67k\Omega, C_1 = C_2 = C_3 = C_4 = C_5 = C_6 = 1\mu F. \end{aligned}$$

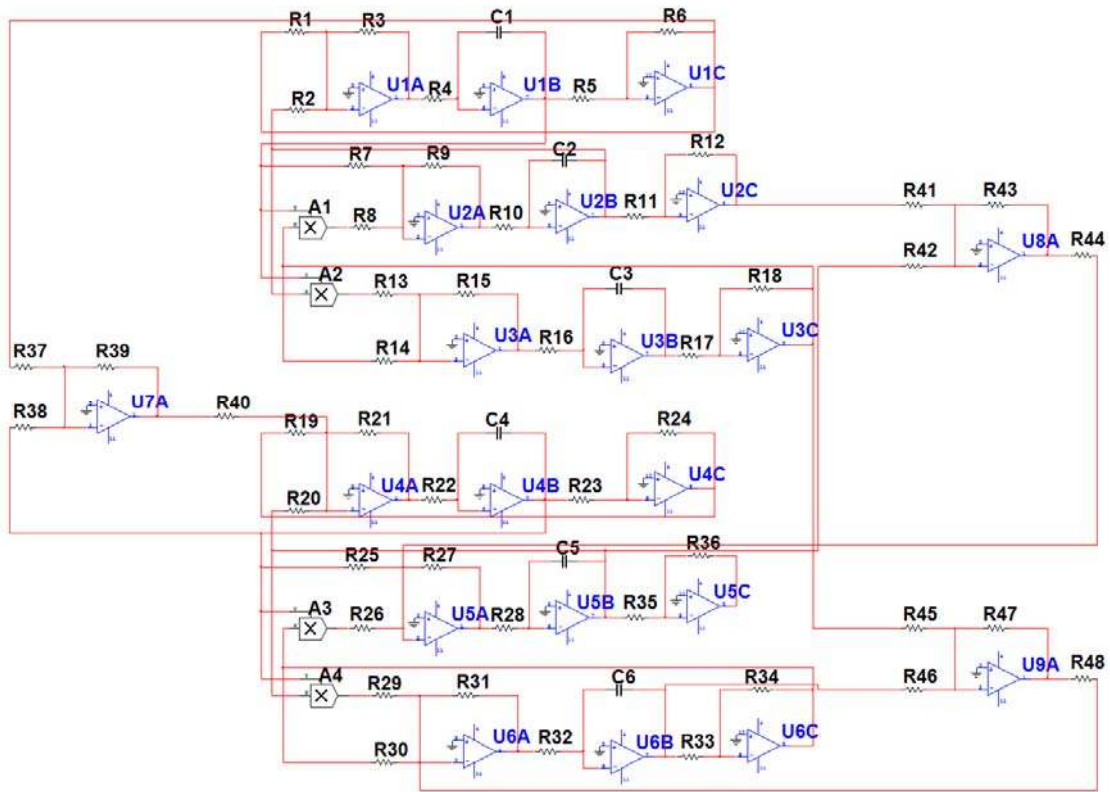
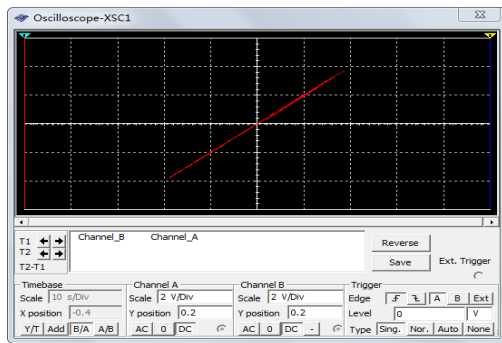
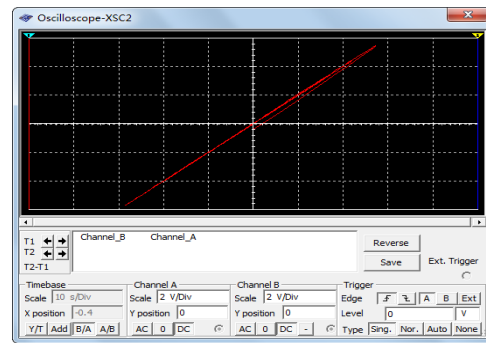

Figure 6. Synchronization of chaotic attractor circuit



$$x_1 - x_2$$



$$y_1 - y_2$$

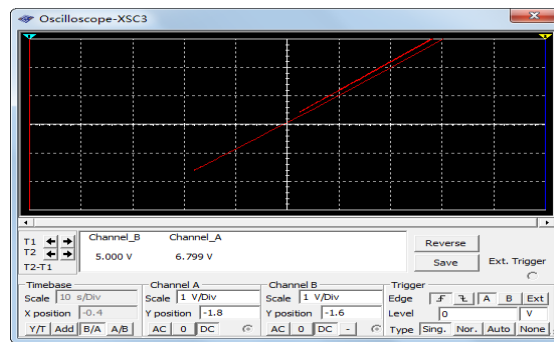

$$z_1 - z_2$$

Figure 7. Output trajectories of the circuit simulation for synchronization of system (8)

Due to the fact that output signal can recover input signal, it indicates that it is possible to create secure communication for a chaotic system. It is necessary to make sure the parameters of transmitter and receiver are identical for implementing the chaotic masking communication. In this paper, secure communication circuit based on chaotic system is structured out, as shown in Fig 8. We use TL084CN operational amplifiers, appropriate valued resistors, inductor and capacitors for Multisim simulations. Useful signal is sinusoidal signal that is added to the synchronizing driving chaotic signal in order to regenerate a clean driving signal at the receiver. Thus, the message has been perfectly recovered by using the signal masking approach through synchronization in the chaotic autonomous attractor.

The sinusoidal signal is added to the generated chaotic x signal, and $s(t) = m(t) - x_1$ is feed into the receiver. The chaotic x signal is regenerated allowing a single addition to retrieve the transmitted signal, $m'(t) = s(t) + x_2 = m(t) - x_1 + x_2 \approx m(t)$, if $x_1 \approx x_2$. Fig. 9 shows Multisim simulation results of this chaotic masking circuit.

The launch system can be described by:

$$\begin{cases} \dot{x}_1 = a(y_1 - x_1) + km(t) \\ \dot{y}_1 = abx_1 - ax_1z_1 \\ \dot{z}_1 = x_1y_1 - (a + c)z_1 \end{cases} \quad (10)$$

The receiving system can be described by:

$$\begin{cases} \dot{x}_2 = a(y_2 - x_2) + k(s(t) - x_2) \\ \dot{y}_2 = abx_2 - ax_2z_2 + k(y_1 - y_2) \\ \dot{z}_2 = x_2y_2 - (a + c)z_2 + k(z_1 - z_2) \end{cases} \quad (11)$$

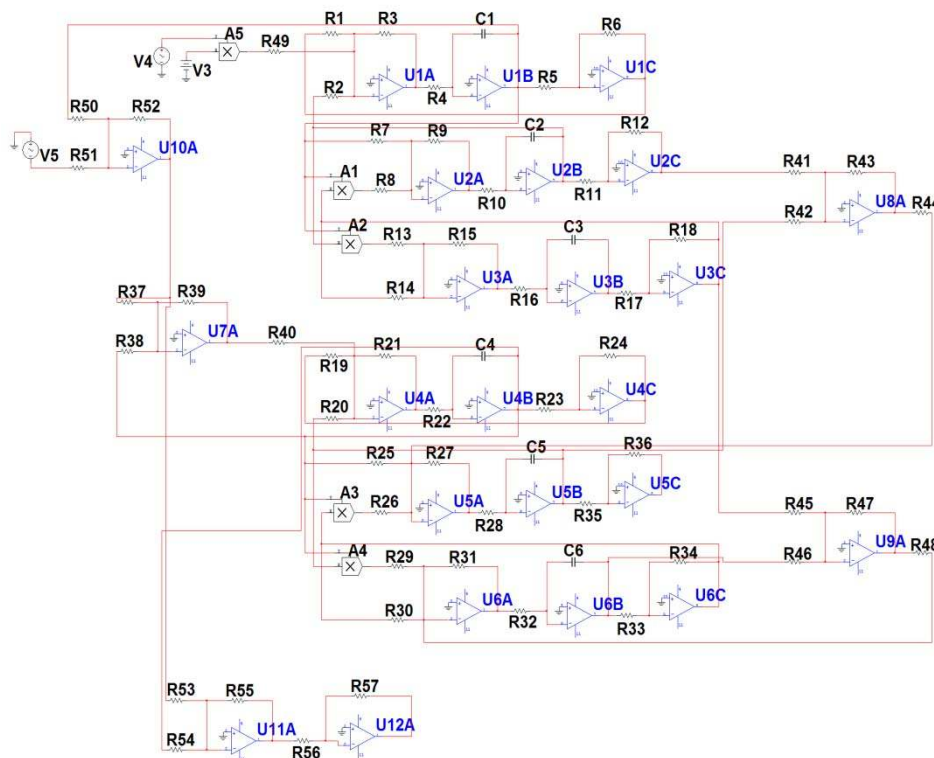
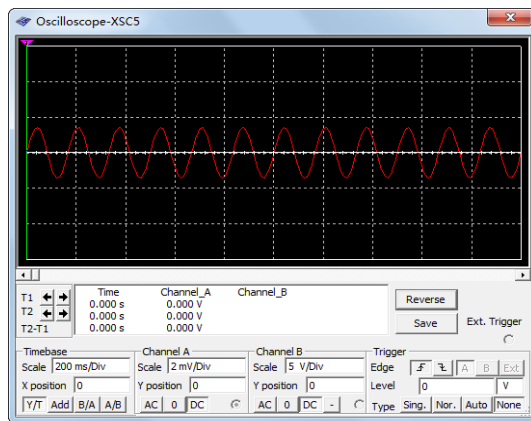

Figure 8. Circuit diagram for realizing secure communication

The circuit parameters of Figure 8 are

$$R_1 = R_2 = R_{14} = R_{16} = R_{19} = R_{20} = R_{30} = R_{32} = 100k\Omega, R_3 = R_8 = R_9 = R_{13} = R_{15} = R_{21} = R_{26} = R_{27} = R_{29} = R_{31} = 10k\Omega, R_4 = R_{10} = R_{22} = R_{28} = 20k\Omega, R_7 = R_{25} = 25k\Omega, \\ R_5 = R_6 = R_{11} = R_{12} \\ = R_{17} = R_{18} = R_{23} = R_{24} = R_{33} = R_{34} = R_{35} = R_{36} = R_{37} = R_{38} = R_{39} = R_{41} = R_{42} = R_{43} = R_{45} = R_{46} = R_{47} = R_{50} = R_{51} = R_{52} = R_{53} = R_{54} = R_{55} = R_{56} = R_{57} = 1k\Omega, R_{40} = R_{44} = 333.33k\Omega, \\ R_{48} = 66.67k\Omega, C_1 = C_2 = C_3 = C_4 = C_5 = C_6 = 1\mu F.$$



Information signal $m(t)$

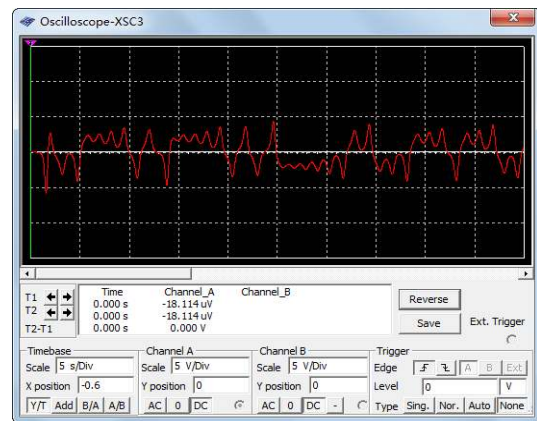

chaotic signal x

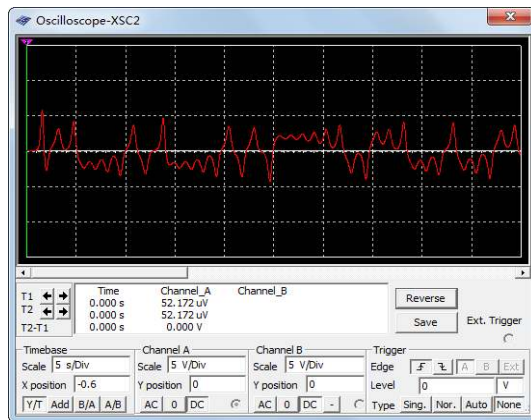

chaotic masking transmitted signal $S(t)$

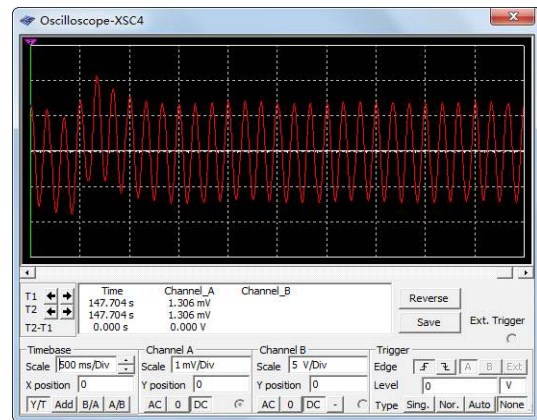

retrieved signal $m'(t)$

Figure 9. Transmission of a sinusoidal signal through chaotic secure communication systems

7. Conclusion

In this paper, a new chaotic system is proposed and studied. Dynamical behaviors of the new system are analyzed, both theoretically and numerically. The system has rich chaotic dynamics behaviors. We have demonstrated in simulations that chaos can be synchronized and applied to secure communications. Chaos synchronization and chaos masking were realized using Multisim programs.

References

- [1] Liu CX, Liu T, Liu L. A new chaotic attractor. *Chaos Solitons and Fractals*. 2004; 22(5): 1031-1038.

-
- [2] Chu YD, Li XF, Zhang JG. Computer simulation and circuit implementation for a new autonomous chaotic system. *Journal of Sichuan University: Natural Science Edition*. 2007; 44(3): 596-602.
- [3] Zhou P, Wei LJ, Chen XF. A hyperchaos system with only one nonlinear term. *Acta physica sinica*. 2009; 58(8): 5201-5208.
- [4] Gang Feng Yan, Xian He Huang. Chaos on Phase Noise of Van Der Pol Oscillator. *TELKOMNIKA Indonesian Journal of Electrical Engineering*. 2010; 8(3): 301-308.
- [5] Jianming Liu. High-Dimensional Chaotic System and Its Circuit Simulation. *TELKOMNIKA Indonesian Journal of Electrical Engineering*. 2013; 11(8): 4530-4538.
- [6] Li XF, Chu YD, Zhang JG. Nonlinear dynamics and circuit implementation for a new Lorenz-like attractor. *Chaos Solitons and Fractals*. 2009; 41: 2360-2370.
- [7] Stouboulos IN, Miliou AN, Valaristos AP. Crisis induced intermittency in a fourth-order autonomous electric circuit. *Chaos Solitons and Fractals*. 2006; 33: 1256-1262.
- [8] Mada S, Halimatussadiyah, Dian SM. Bidirectional chaotic synchronization of nonautonomous circuit and its application for secure communication. *World Academy of Science, Engineering and Technology*. 2011; 80: 1067-1072.
- [9] Miliou AN, Stavrinos SG, Valaristos AP. Nonlinear electronic circuit. Part I: Multiple routes to chaos. *Nonlinear Anal*. 2009; 71: 3-20.
- [10] Haniyas MP, Tombras GS. Time series cross prediction in a single transistor chaotic circuit. *Chaos Solitons and Fractals*. 2009; 41:1167-1173.
- [11] Kuntanapreeda S. Chaos synchronization of unified chaotic systems via LMI. *Phys. Lett. A*. 2009; 373: 2837-2840.
- [12] Njah AN, Ojo KS, Adebayo GA. Generalized control and synchronization of chaos in RCL-shunted Josephson junction using backstepping design. *Physica C, Supercond*. 2010; 470: 558-564.