Selective Mode Excitation: A Technique for Advanced Fiber Systems

Dmitry V. Svistunov

Additional information is available at the end of the chapter

<http://dx.doi.org/10.5772/intechopen.68409>

Abstract

Actual problems arising in development of fiber optical systems are increasing the information capacity and enhancing data security. Different encoding methods and data compression techniques have been developed to meet these requirements. The presented materials emphasize advantages of application of selective mode excitation in fiber systems that lead to both increasing the system information capacity and enhancing data security. Three-stage hierarchical scheme of data compression [where time division multiplexing (TDM) method is the content of the first stage, the second stage utilizes wavelength division multiplexing, and mode division multiplexing (MDM) is applied at the last stage] is discussed. Furthermore, it is highlighted that selective mode excitation is able to embarrass eavesdropping. It is shown that just application of the mentioned technique allows enhancing data security, while designing of special system architectures provides additional increase of data protection level. The examples of such system schemes are presented. Thus, application of selective mode excitation could improve the performances of fiber systems significantly, at least the ones such as short- and middle-haul communication lines and local area networks (LANs).

Keywords: selective mode excitation, information capacity, data compression, mode division multiplexing, data security

1. Introduction

The demands on increasing the information capacity of fiber systems and also on higher secrecy are declared the whole time since optical communication came to the practical stage of commercial systems, and intensive investigations have been performed in order to meet the mentioned requirements.

Regarding improvement of data security, conducted research resulted in a number of developed encoding algorithms and the specific methods as quantum cryptography that can embarrass decoding of eavesdropped information significantly.

As for information capacity, substantial progress has been achieved by employment of data compression methods. Various developed techniques can be combined in several groups by operating functions. The first group—time division multiplexing (TDM) method—had been developed for wire and radio communications and then was implemented also in optical fiber communication on appearance of fiber systems. That method bases on managing the launch of different input signal streams in turn to the same trunk line. In TDM method, time domains (frames) are defined, and each one is divided into several time slots which are filled with the data blocks of transmitted signal streams. While former applications of the method use managing the electric signals (ETDM), the latter application employs also extra techniques performing switching of optical signal streams (OTDM). Whereas a number of variants of TDM method have been developed, further works on TDM techniques and algorithms are still performed actively.

The next group—wavelength division multiplexing (WDM) method, was implemented later upon achieving appropriate performances and lower costs of required fiber system units. The method uses single optical fiber for parallel independent transmission of various light signals of different wavelengths. Performed standardization resulted in defining several wavelength windows and also wavelength channel spacing into the window. Maximal system information capacity can be reached under employment of dense WDM (DWDM) technique capable of providing minimal channel spacing defined by the standardized spectral grid for 12.5 and 25 GHz separations. Presently, WDM techniques have wide application in current fiber systems.

Evident way to get further increase of system information capacity is cooperative employment of different data compression techniques in advanced systems. Conducted research resulted in application of WDM method in combinations with ETDM or OTDM techniques mainly in single-mode fiber (SMF) systems and also in short-haul multimode systems. Developments of the latter systems have led to elaborating a promising approach to significant increasing the bandwidth-distant products of those systems: selective excitation of sole mode within multimode fiber that allows obtaining a regime of quasi-single-mode data transmission. The way to get further substantial rise of information capacity of those systems is employment of the specific data compression method named mode division multiplexing (MDM). Selective mode excitation is a crucial technique of that method, and the interest to research on that theme rises year-by-year.

Here, our subject is to consider possibility of complex employment of noted data compression methods. Furthermore, we shall show that application of selective mode excitation in the form of MDM technique allows enhancing data security due to just application of the method, while designing of special system architectures provides additional increase of data protection level.

2. Hierarchic scheme of data compression

The essence of MDM technique is the use of different fiber modes or mode groups of the same multimode fiber as independent information channels. High level of intermodal coupling in

former commercial fibers delayed implementation of this method for a long time. However, achieved progress in fabrication technology reduced drastically the intermodal coupling (as for example, the average level of intermodal coupling coefficient as 0.007 km^{-1} for the case of neighbor-order modes had been reached already in the past decade [1]). Due to that progress, propagation of sole modes has been obtained in multimode commercial fibers, and further investigations concentrated just on realization of MDM technique. First of all, different selective mode couplers had been developed, and designing of experimental systems started. One group of developments was directed to application of MDM to coherent systems in order to reach long-haul trunk lines. However, these systems are complicated and high cost. On the other hand, a number of short- and middle-haul current fiber systems are based on multimode fibers. Bearing in mind, the possibility to reconstruct those systems by application of MDM technique; further, we consider low-cost direct detection systems that are quite appropriate for mentioned trunk lengths. By present, experimental MDM-based systems are developed demonstrating the available distances being sufficient for fiber systems such as metropolitan or toll lines and local area networks (LANs) (for example, [2, 3]). As feasibility of MDM systems is proven practically, the goal of the next stage is complex combination of this technique with other data compression methods.

Cascade scheme of data compression is shown in **Figure 1**. The scheme is capable of providing hierarchical three-level compression of data streams. Primary stage of data processing in the scheme bases on TDM techniques issuing the set of compressed data streams each intended for separate spectral channel. The second stage uses WDM method that joins a number of spectral channels in the same fiber. Application of MDM technique is the content of the third stage. At this stage, each compressed optical signal resulting from previous stages launches certain separate mode of multimode trunk fiber. The scheme has a symmetric structure, and reverse sequence of those stages at the receiver part provides recovering the initial data streams.

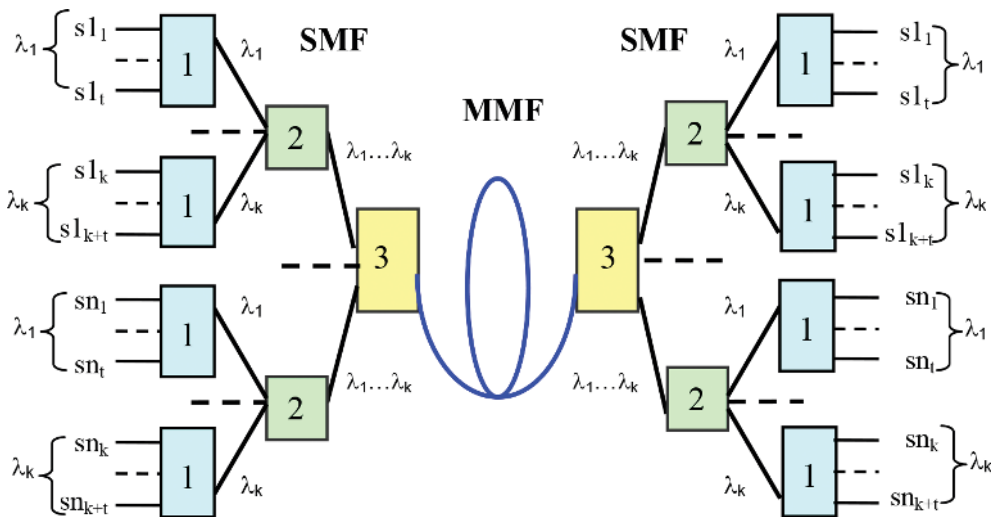

Figure 1. Hierarchical cascade scheme of data compression in multimode fiber systems. The blocks denote the devices of following types: 1 is TDM; 2 is WDM; 3 is MDM.

Multimode fiber (MMF) is utilized as a trunk fiber, while single-mode fibers (SMFs) required for optimal operating of mode multiplexers are employed in other optical interconnections into the scheme.

Every mode channel in multimode fiber can be considered as an analogue to separate single-mode fiber for which cooperative implementation of TDM and WDM techniques is already proven. So, the question concerning the proposed scheme is whether mutual compatibility of developed WDM and MDM operating units is limited restricting common application of the techniques.

Feasibility of the considered scheme depends on ability of mode multiplexers/demultiplexers to operate effectively in some spectral range. Those units are based on selective mode couplers which excite/detect independently fiber modes of different orders. A set of such elements basing on different operating principles have been developed (for example, [4–16]). In most cases, selective excitation of fiber modes is performed with external units that are built as waveguide (fiber or integrated optical) elements or bulk devices based on traditional optical elements. Optical matching of those units with the fibers is performed by traditional or GRIN lenses, and also butt joining is used for waveguide elements. Waveguide selective mode couplers require special consideration. Particularly, the attention should be paid to selective units whose operating principles lead to dependence of directions of intrinsic light propagation on the light wavelength. Waveguide mode multiplexer/demultiplexer described in Refs. [17, 18] is just the unit of this kind, and experimental samples of the unit were examined to determine the noted dependence.

Scheme of the considered unit is shown in **Figure 2**. Planar selective element operates as known input/output prism coupler and matches optically each mode of the multimode channel waveguide with the corresponding waveguide beam in single-mode planar region joined with the set of single-mode channel guides by horn transition structures. The angle α between the axis of certain planar beam and multimode channel guide depends on the ratio of mode indices of that beam and corresponding channel mode. As planar selective coupler is the key element of the unit, experimental samples of this element have been studied by measurement of directional diagrams of planar beams [19] in order to estimate whether those beams become superimposed if the channel waveguide is excited with light of certain spectral bandwidth.

Reliable accurate measurement of beam directivity diagram into planar waveguide could be difficult; therefore, extra prism input/output coupler having cylindrical base was applied, and directional diagrams of output beams were measured. **Figure 3** presents the results of examinations of the trial sample. Numerical angular values at the diagram axis correspond to goniometric readouts under arbitrary benchmark position. Obtained patterns are typical for all couplers of this kind. Every peak corresponds to the separate planar beam associated with the certain channel mode.

Study of the sample intended for operating at light wavelength as $1.3 \mu\text{m}$ and simulation of coupler excitation with light of whole standard O bandwidth showed that angular widths of three neighbor planar beams become as 22, 20, and 16 arcmin, while the angles between the

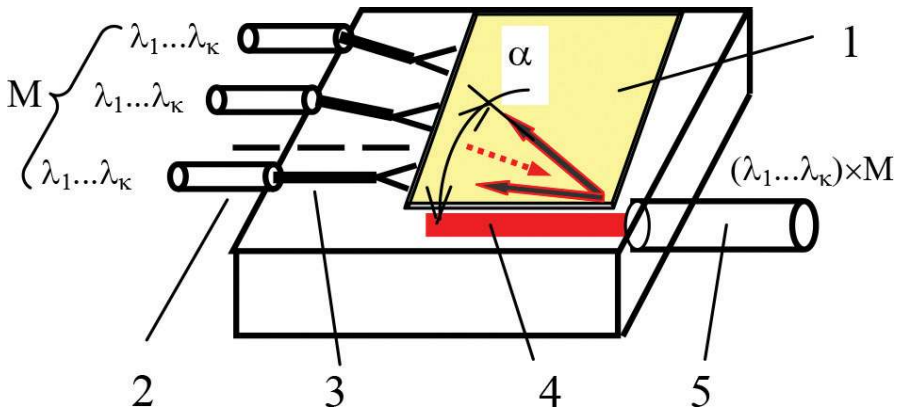

Figure 2. Scheme of waveguide unit for selective mode excitation/detection. 1 is single-mode planar section; 2 is SMF; 3 is single-mode channel waveguides with horn transitions; 4 is multimode channel waveguide; 5 is MMF.

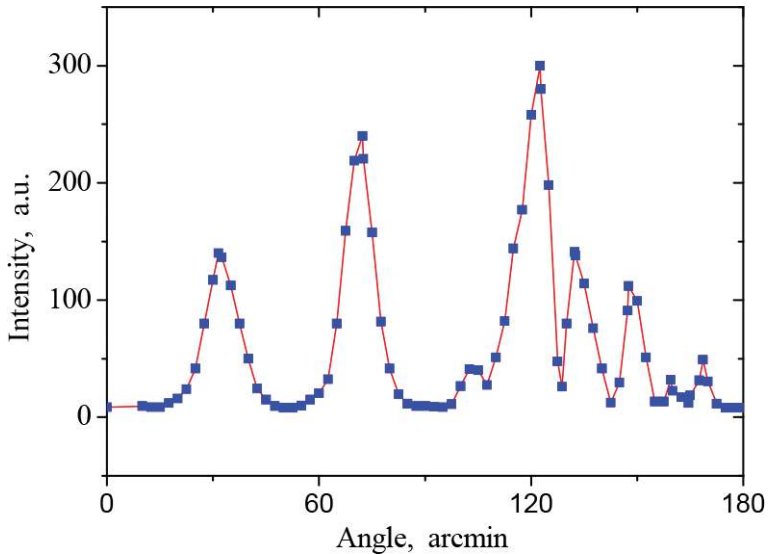

Figure 3. Angular distribution of light beams associated with the set of excited channel modes.

axes of adjacent beams are 64 and 33 arcmin [19]. These results indicate that the beams are spatially separated and can be directed to corresponding horn structures without appearance of significant crosstalk. So, the experimental results confirm that this mode multiplexer is capable of operating with optical signals compressed by WDM.

Considering that the mentioned mode multiplexer is assumed to be among the ones having perceptible spectral sensitivity, we can note compatibility of MDM and WDM units and

conclude that the obtained results prove feasibility of cooperative application of MDM and WDM techniques. Thus, the mentioned hierarchic scheme of data compression can be realized.

3. Enhancement of data security

Nowadays, protection of transmitted data from eavesdropping is considered as a crucial problem, and intensive investigations are aimed to development of new approaches leading to effective solutions. One branch of developments is counteracting to eavesdropping under intrusion to the trunk fiber line. In order to understand the challenge, let us estimate what techniques could be applied for illegal data reading from the fiber bearing in mind that the essence of eavesdropping means that only minor part or optical power is spit off, otherwise alarm signals are issued by the control system blocks. Therefore, partial mode extraction to lateral direction is to be performed in some intrusion procedure, while the main part of optical power propagates further into the fiber. Some possible variants of the mentioned impact on the fiber are shown in **Figure 4**.

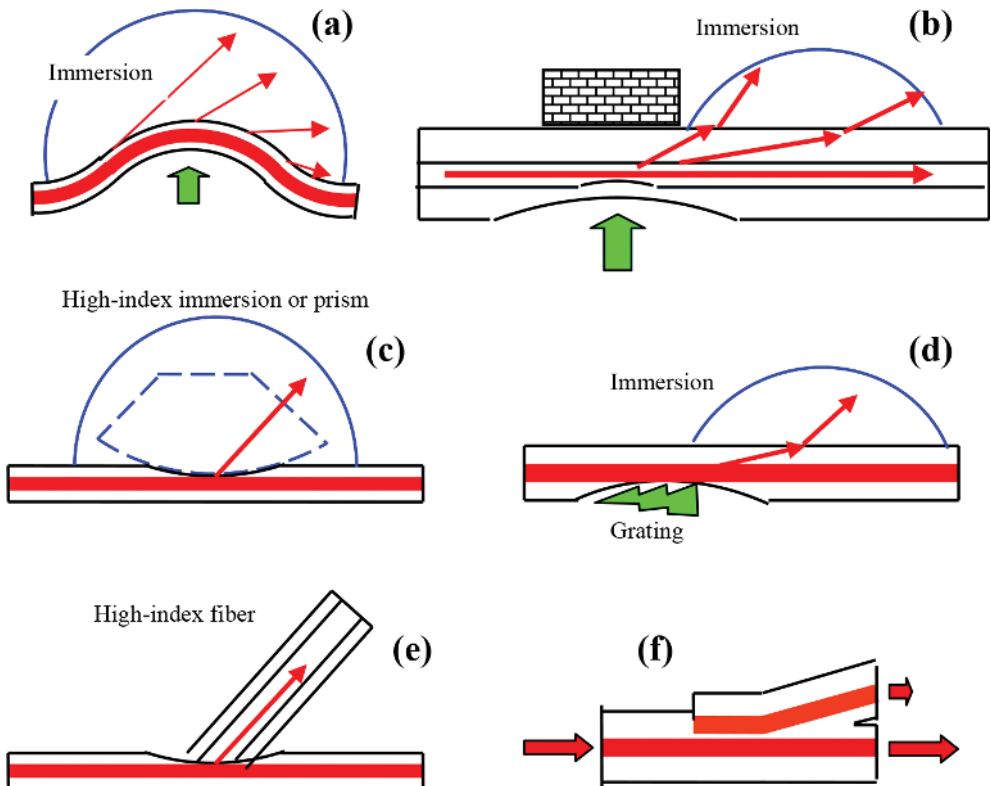

Figure 4. Variants of impact on the fiber resulting in partial extraction of the optical power from the fiber modes: fiber bending (a), local pressing (b), prism-like (c), and diffractive (d) couplers, higher-index fiber (e) and as all-fiber coupler (f).

Rather simple way to perform mentioned eavesdropping is to bend the fiber. Then, bent losses occur because the part of the tail of mode field cross distribution is cut off due to fiber bending and launches separate light beam (namely cladding mode) propagating into the fiber cladding. Those cladding modes form light beams in the adjacent medium due to scattering on cladding imperfections or refraction if the medium is higher index. Mode leakage increases as the bend radius decreases. As the leakage reasons remain the same along the bend, mode transformation occurs at every point of bent fiber, and the whole radiated beam is high-divergent as it is shown in **Figure 4a**. Similar technique uses microbendings (obtained with pressed special tools as it is performed in some pressure sensors) and/or deviations of the core radius caused by local impact to the fiber (see **Figure 4b**). In those cases, a part of fiber mode power is also split off being proportional to the pressure strength and forms cladding beams that can be outcoupled with immersion drop and registered.

The noted splitting techniques do not require preliminary treatment of fiber inner cladding, only outer protective jackets must be removed. The next variants exploit optical tunneling effect so they need affecting the cladding adjacent to fiber core. Appropriate gap between the applied tool and the fiber core can be obtained by partial remove of cladding layer, for example with etching by dropped chemical reagent or pressing under heating. Upon preparing the gap, higher index immersion is placed to the formed contact region or a bulk prism is pressed, and one obtain splitting tool operating as known longitudinal input/output prism couplers where the level of extracted optical power depends on combination of refractive indices and also on the gap length and thickness. Spatial extracted beams are formed directly with such tool drawn in **Figure 4c**. That variant of impact on the trunk fiber under illegal data reading seems more difficult in use but more dangerous with relation to the mentioned manner of data protection because longitudinal couplers can spatially separate output light beams associated with the modes of different orders. Similar tool can use external diffraction grating placed to the contact area with grating strokes normal to the fiber axis as shown in **Figure 4d**. The effective regime of that diffractive tool is realized when a long-period grating transfers the mode power to cladding modes. A higher index extra fiber can also replace the bulk prism as shown in **Figure 4e**. End face of the extra fiber is placed to the contact region, while its axis forms a certain angle with the trunk fiber. If inclination of the extra fiber provides meeting the condition of phase matching of the modes in both fibers, mode launching occurs in the extra fiber due to optical tunneling through the cladding gap. And of course, optical tunneling can be performed by exciting the extra fiber located along the trunk fiber as in all-fiber directional couplers (see **Figure 4f**). Treatment of fiber claddings is also necessary in this case in order to provide appropriate coupler structure.

It is shown in Ref. [20] that selective mode excitation has a valuable advantageous feature: being simply employed in the form of MDM technique, selective mode launching can resist seriously to eavesdropping performed with noted intrusion techniques. Indeed, fiber bending results in light irradiation in all points along the formed fiber curve. So, every fiber mode is associated with the certain highly divergent output beam having angular width equal to the central angle of the fiber bend arc. Evidently, these output beams superimpose when different fiber modes propagate simultaneously. Then, the information in the registered eavesdropped signal becomes mixed.

Similar situation occurs in cases of microbendings and core radius variations where every core mode excites a group of cladding modes of adjacent orders, and information carried by neighbor fiber modes becomes mixed just at this stage because the same cladding mode groups appear from different fiber modes. When these cladding mode groups are split off with placed immersion or fiber macrobending, or if scattering at cladding imperfections is registered, a degree of information mixing rises.

As for the scheme employing optical tunneling to high-index immersion drop or pressed bulk prism, consideration performed in Ref. [20] for commercial MMF showed that one can also expect a superposition of output space beams accompanied with information mixing if neighbor fiber mode groups are used for data transmission according to the MDM scheme. Similar assumption concerns the external grating tool because of likeness between performances of space beams formed by prism and grating directional couplers operating as longitudinal directional input/output units. Mixed information can also be expected in case of application of extra higher index fiber. Difference between mode spectra of trunk and mentioned fibers does not allow choosing the fiber inclination angle that could provide meeting the matching conditions for the set of modes simultaneously, and parasitic mode launching occurs in the extra fiber leading to cross-talk and mixing the data read from different mode channels.

The last noted splitting scheme is tunneling to the extra fiber along with the fiber length. In this case, particularly if both fibers are of the same type, simple application of MDM technique can fail in data protecting, and special system schemes should be built to counteract eavesdropping.

First of all, the fiber system must be capable of detecting the intrusion attempt and issue the alarm signal. This important feature is already realized in some fiber systems, for example, in the experimental system described in Ref. [21]. That system exploits selectively excited fundamental mode of graded-index MMF for high-bit-rate data transmission, and that mode is launched with external strip waveguide by on-axis butt joint. Another strip waveguide of that external chip excite several higher order fiber modes by off-axis butt joint, and these modes form together the monitor channel. Due to the character of mode field cross distributions, higher order modes are more sensitive to fiber bending and other variants of impact on the fiber than the fundamental mode. Therefore, monitor signal decreases immediately at the beginning of intrusion, and the control block issues the alarm signal timely. Because of the used mode coupler, only selectively excited lowest order fiber mode can be exploited for high-bit-rate data transmission in the built system. However, application of the mode coupler of another type could enable employing the MDM technique and providing parallel transmission of additional data streams and/or random signals, while the monitor channel still controls intrusion attempts. Besides the increase of the system information capacity that could allow achieving additional enhancement of data security in the system due to the reasons noted above. Data transmission part of the system of that kind is shown schematically in **Figure 5**.

Of course, the presented scheme can be reorganized to bidirectional transmission by adding the appropriate system blocks. The features to be remained in the scheme revisions are application of MDM technique for low-order modes and building the monitor channel for higher order modes.

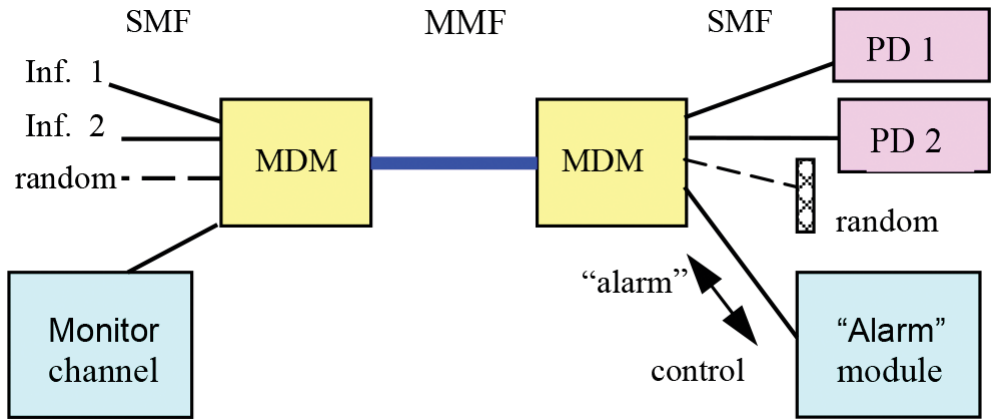

Figure 5. Scheme of transmission part of MDM system with monitor/alarm line. PD is photodetector.

Another possible system scheme could use a specific technique of data transmission. As in TDM technique, the data stream can be divided in time periods each containing data blocks. Each block of the same data period is directed individually to the certain optical delay line. The kit of delay lines provides time synchronization of blocks at the line outputs. Then, the optical signal from each line is transmitted over the certain mode of the trunk fiber. So, we obtain simultaneous transmission of originally sequential data blocks. At the end of trunk fiber, outcoupled mode signals pass via the output kit of delay lines performing reversal time shifts of data blocks and thus providing restoration of their original sequence. **Figure 6** shows the

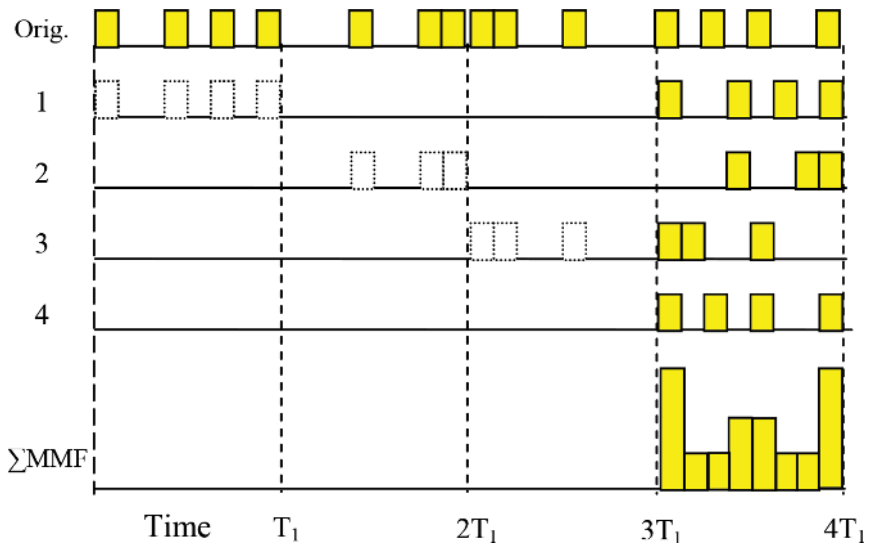

Figure 6. Time distribution of data bit blocks by the modes of the trunk fiber.

example of distribution of data stream by four trunk fiber modes. Here, one data time period is demonstrated as a bit stream in NRZ format.

In order to simplify the diagram, the period length is extremely shortened, and only 8 bits are included into each data block. T_1 denotes the time duration of one data block, while the numbers at the lines correspond to different operating trunk fiber modes. Four fiber modes having different principal mode numbers can be really excited independently (it follows, for example, from **Figure 3** where experimental characteristics of the selective mode coupler are presented). One can see that individually delayed data blocks come to the trunk fiber input simultaneously as they are shown within the time range $3T_1 \dots 4T_1$.

The signal denoted as Σ MMF represents the superposed data resulted from eavesdropping by fiber bending or similar nonselective technique. However, even if different fiber modes are distinguished in some intrusion procedure, decoding of the read data is massively impeded because the eavesdropper must determine right sequence of registered data blocks.

Figure 7 presents the scheme capable of performing the proposed technique for the noted case of four mode channels into the trunk fiber. The circles at SMF lines denote optical delay lines which can be represented by fiber loops of certain lengths. The extra line is reserved for random signal that could be transmitted over fifth selectively excited fiber mode filling the “empty” time windows $0 \dots 3T_1$ appeared in the trunk fiber.

The data distributor can be built as the integrated optical chip combining known waveguide switches as it is shown in **Figure 8** together with the time diagram of tuning electric signals. For simplicity of the pattern, only one of every pair of switch electrodes is plotted.

Distributor provides division of data period to data blocks and individual directing each block to corresponding output channel. The input signal is the original data bit sequence. Every switch is activated with tuning electric impulse whose duration equals to the chosen duration of the data block. Consecutive turning on the switches performs directing the consecutive data blocks to different outputs of the distributor, and time distribution of those data blocks by device outputs is depicted in **Figure 6** as dotted bit images. According to the scheme shown in **Figure 7**, each output of the distributor is joined with the corresponding SMF delay line. Performing individual delaying, those lines synchronize data bit blocks at the input of the MDM unit as it is seen in **Figure 6** in the time range $3T_1 \dots 4T_1$. The MDM unit matches each

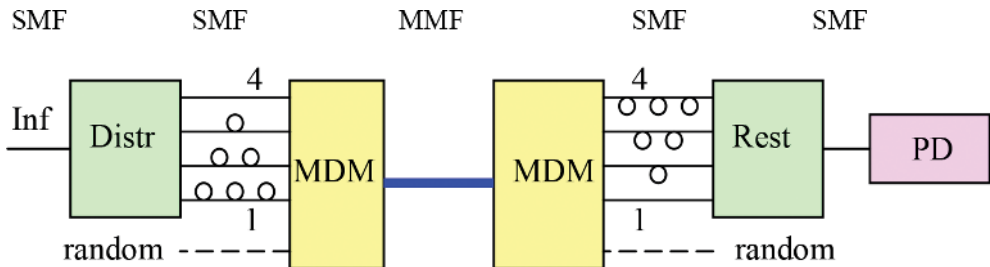

Figure 7. Scheme of transmission part of MDM system performing distribution of information data sequence by trunk modes.

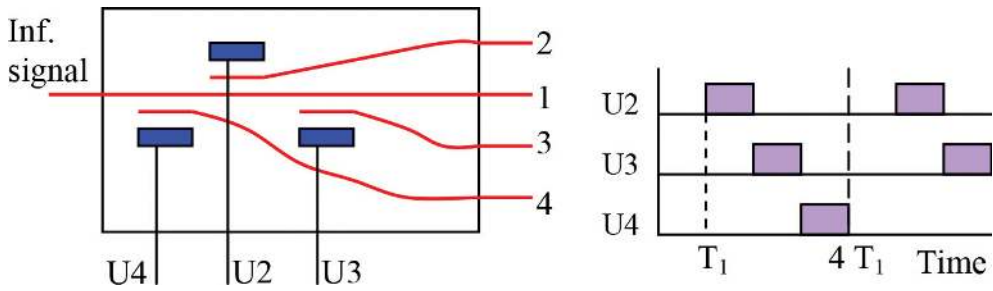

Figure 8. Scheme of data distributor/restorer together with the diagram of tuning voltage.

delay line with the certain trunk mode, and shown distribution of delayed data bit blocks represents time distribution of light pulses by different trunk fiber mode channels at the entire end of trunk line.

Let us evaluate the required lengths of SMF delay loops at the transmitter for the scheme with four mode information channels into the trunk fiber. The length of the certain SMF at the input of the MDM unit can be written as

$$L_i^{inp} = L_4^{inp} + (4 - i) \cdot \delta L_i \tag{1}$$

where i is the number of SMF (let us define that the signal from the first SMF is to be coupled to the trunk fiber of lower order); $\delta L_i = cT_1/N_{ms} = cK_b/fN_{ms}$ is the difference between the lengths of two neighbor SMFs; c is the light speed in vacuum; K_b is the amount of bits in the data block; N_{ms} is the mode index of SMF; f is the data stream frequency. L_4^{inp} corresponds to the SMF line whose signals are not delayed specially, and this length is minimal among four SMFs being defined by constructive reasons only. For $K_b = 8, f = 800$ MHz, $N_{ms} \approx 1.47$ (for $\lambda = 1.3 \mu\text{m}$), we obtain from Eq. (1) $\delta L_i \approx 2$ m. Although the used data block length is too small for practice, this rough evaluation resulted in the reasonable meaning of δL_i which could be still appropriate for block lengths of more than ten times longer. The frequency of tuning electrical signal applied to data distributor is $f_{el} = f/K_bK_{ic}$, where K_{ic} is the amount of mode informational channels. In the considered example $K_{ic} = 4$, and then $f_{el} = 25$ MHz that is also the reasonable value which will decrease inversely to the rise of data block length.

Regarding SMF loops in the receiver system part, corresponding SMF lengths should be in reversal relation in order to compensate data block delays performed in the transmitter and to recover original data sequence. Furthermore, here the differences in propagation times of different trunk fiber modes must be considered additionally. So, the length of the certain SMF in the receiver becomes as

$$L_i^{out} = L_1^{out} + (i - 1) \cdot \delta L_i + \delta L_i^{dmd} \tag{2}$$

where L_1^{out} is the length of shortest output SMF whose optical signal is not delayed specially in processing at the receiver. δL_i^{dmd} is the increment of SMF length defined by intermodal dispersion in the trunk MMF. That increment can be determined as

$$\delta L_i^{dmd} = c\delta t_i/N_{ms} \quad (3)$$

where δt_i is the differential delay time of the corresponding trunk mode. Depending on the types of employed trunk fibers, this delay time can vary in a wide range having significantly larger values in step-index fibers than the ones in graded-index fibers.

Maximal delay time caused by intermodal dispersion can be determined from optical pulse broadening when the whole mode spectrum is launched. Then, the specific delay related to the trunk fiber length is

$$\delta t_{sf}/L_{tr} = n_1\Delta/c \quad (4)$$

where $\Delta = (n_1 - n_2)/n_1$, L_{tr} is the fiber length; n_1 is the maximal index in the core cross-section (uniform value in a step-index fiber); n_2 is the cladding index [22]. Substituting to Eq. (4), the values $n_1 = 1.48$ and $\Delta = 0.01$ for the case of step-index fiber, we obtain $\delta t_{sf}/L_{tr} \approx 50$ ns/km that seems too big despite delay times for several low-order neighbor modes are evidently less. The first scheme with control/alarm line and independent data channels seems more appropriate for step-index fiber systems.

Unlike that fiber type, graded-index fibers demonstrate much less intermodal delay due to the nature of mode propagation via the fiber with radial refractive index cross distribution. The intermodal dispersion reaches minimal values when the index cross profile is close to a parabolic form. Optimization of profile decrement parameters for the chosen wavelength allows reaching the values of maximal delay less than 100 ps/km for $\Delta = 0.01$, but then, the real index profile must correspond precisely to the theoretical one. In practice, the value as about $\delta t_{gf}/L_{tr} \approx 1$ ns/km can be chosen in approximate estimations as a maximal delay time in commercial graded-index fibers. Now, let us evaluate a differential delay time in such fibers. Considering the performances of MMFs having parabolic-like index profile in circular cross-section, one finds equidistant dependence of mode propagation constant β in terms of β^2 on the principal number M (the value characterizing separate mode groups each containing the set of degenerate fiber modes; just those groups can be exploited as information channels), and group mode indices can also be assumed approximately equidistant. Total amount of mode groups is evaluated as

$$M_0 = kn_1a(\Delta/2)^{1/2} \quad (5)$$

where a is the core radius; $k = 2\pi/\lambda$; λ is the light wavelength in vacuum [23]. Equidistant mode indices mean equidistant distribution of mode group velocities that in turn lead to equal increments of delay time counted between adjacent mode groups. Therefore, for our case of four mode channels, we obtain following term that determines the specific delay time with respect to propagation of the fastest mode:

$$\delta t_i/L_{tr} \approx \delta t_{gf}(4 - i)/M_0L_{tr} \quad (6)$$

Then, the desired SMF length increment for the case of graded-index trunk fiber is

$$\delta L_i^{dm} \approx c(i - 1) \cdot \delta t_{gf} / M_0 N_{ms} \quad (7)$$

(the higher-order mode propagates faster and must be delayed in more degree). Substituting to Eqs. (5) and (7), the values $a = 25 \mu\text{m}$, $\Delta = 0.01$, $n_1 = 1.486$, $N_{ms} = 1.47$, $\lambda = 1.33 \mu\text{m}$, we obtain (for trunk line as $L_{tr} = 1 \text{ km}$) the following set of SMF elongations δL_i^{dm} : 0, 16.5, 33, and 49.5 mm placed here in priority according to the rise of the channel number. For longer trunk lines, one must multiply these values by the factor of the distance in km. Regarding the reasonable trunk distances (no more than 100 km), the SMF lengths required for recovering the original data sequence evidently dominate over these additional elongations in case of graded-index trunk fiber. Additional precise tuning of data block time shifting can be achieved if active fibers with longitudinal electrodes exploiting an electrooptical effect are employed as SMFs in the receiver. Appropriate levels of uniform voltage biases are to be determined in set-up procedures when installing the system.

The functions of restorer and distributor are reversal, and their constructions are symmetric. The restorer has four inputs (in our four-channel example) and one output. Input signals are the data blocks issued from delay lines at the receiver part where they have got individual time shifts that provide right time sequence of these blocks, whereas they propagate in parallel lines yet. These four fiber lines are joined with restorer inputs, and time distribution of the input blocks corresponds to location of dotted data bit images in **Figure 6**. Sequential turning on the restorer electrooptical switches by the tuning voltages (whose diagram is shown in **Figure 8**) enables transferring light pulses of all data blocks to one waveguide (one can imagine reversal light tracing in the scheme plotted in **Figure 8**). Then, the output restorer signal becomes as the original data bit sequence shown in **Figure 6**.

Simple filling the “empty” time windows by random signals in the fifth trunk mode can be replaced with different random bit streams (whose frequencies equal to the data stream frequency) each filling the certain local “empty” window in different trunk fiber mode. Then, the scheme transforms into the variant shown in **Figure 9**.

Every random sequence is divided to random bit blocks by the same manner as described above for the data sequence, and SMF loops are also employed to synchronize random blocks at the input of the MDM unit (those loops are plotted as corresponding circles at the scheme lines). That random blocks are directed from distributors to multiplexing connectors where the channel signals are formed containing each a continuous sequence of one data block and three different random blocks as it is depicted in **Figure 10**.

These signals are multiplexed by the MDM unit providing here filling each trunk mode channel with continuous bit sequences. That circumstance impedes significantly separation of random and data blocks in eavesdropped signal even if trunk modes are distinguished in intrusion procedure.

Upon passage the distance and executing a mode demultiplexing, bit sequences come to the extractor where random signals are omitted, while extracted data blocks are directed further to the restorer and processed there as described above for recovering the original data sequence. **Figure 11** demonstrates the schemes of the multiplexing connector and the extractor together

with the diagram of tuning voltage. The devices are built on widespread elements—known 3dB-splitters and electrooptical switches.

Extractor includes four (for our example) switches each having one output joined with further system scheme line, while another output is empty. The signals that come to every extractor input are the sequences of data and random blocks shown in **Figure 10**. Corresponding blocks come to parallel extractor inputs simultaneously. Therefore, extractor switches are tuned with the same voltage signal (for simplicity, only one electrode of every pair is plotted at all switches). Activating the switches during the time range $T_1 \dots T_4$ every data period, we direct

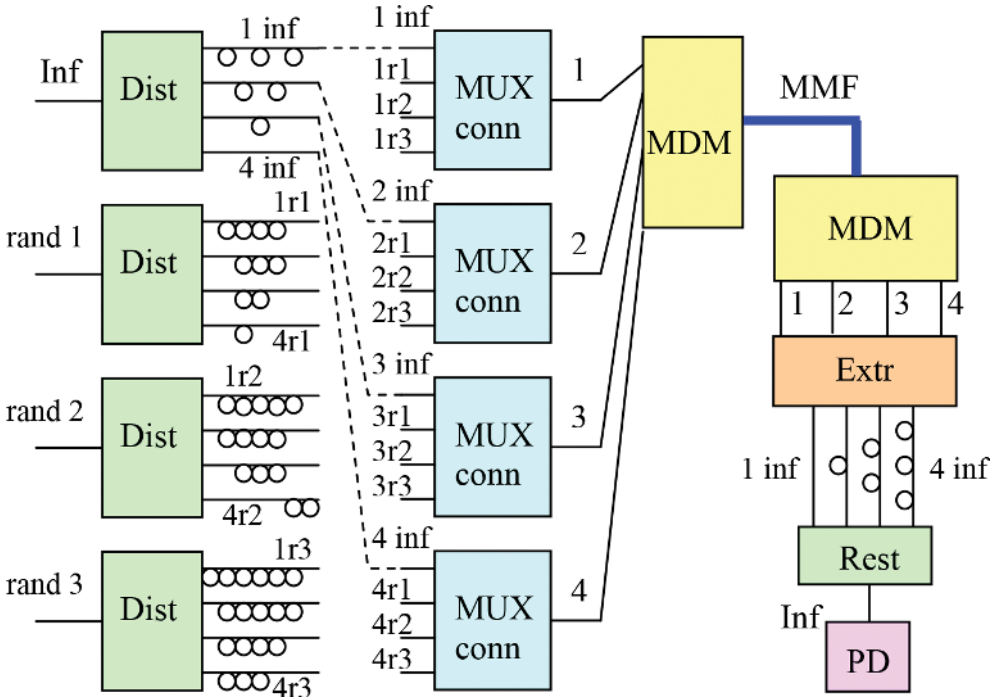

Figure 9. Scheme of transmission part of MDM system performing distribution of information data sequence by trunk modes and filling the empty time windows with random signals.

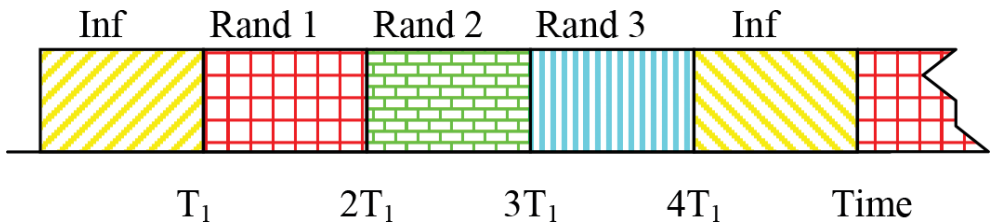

Figure 10. Sequence of data and random bit blocks in each mode of the trunk fiber.

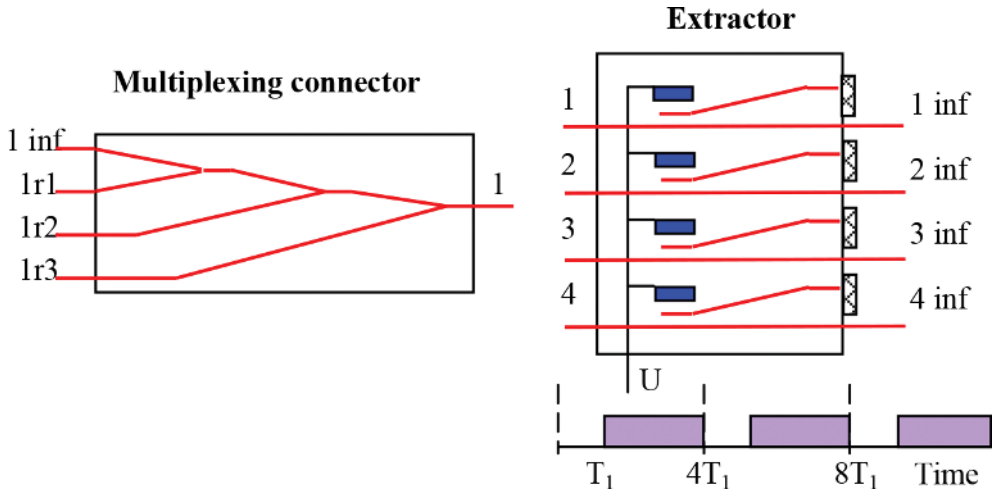

Figure 11. Schemes of the connector and the extractor depicted in Figure 9 together with the diagram of tuning voltage.

the random bit blocks to empty outputs, while the data bit blocks pass through the extractor during times $0 \dots T_1$. Then, the signal at the extractor output is represented by data bit blocks issued simultaneously from four parallel channels, and their distribution by those channels is the same as the one plotted in Figure 6 within time limits $3T_1 \dots 4T_1$. Synchronization of tuning voltages with data blocks can be executed with repeated timely service signals transmitted instead of data bit blocks.

To provide simultaneous coming of the data blocks to extractor inputs, differential mode delay in the trunk fiber must be considered preliminary. Therefore, in this scheme, the lengths of delaying SMFs at the input of MDM unit in the transmitter are determined as

$$l_i^{inp} = l_4^{inp} + (4 - i) \cdot \delta L_i + \delta L_i^{dm} \quad (8)$$

where l_4^{inp} is the length of shortest SMF line, and other values are determined as above using Eqs. (1) and (7). The lengths of SMF delay lines that follow the extractor become as

$$l_i^{out} = l_1^{out} + (i - 1) \cdot \delta L_i \quad (9)$$

where l_1^{out} is the length of shortest SMF corresponding to the lowest order operating trunk mode. Elongation of delaying SMFs for random bit blocks is conducted by the same manner except that the required amount of SMF sections (each of δL_i length) for certain line can be determined from the scheme in Figure 9 as a number of circles plotted at the corresponding line. The delayed signals are directed to the restorer where they are processed as described above. As the result, original data bit sequence becomes recovered.

Considering all above, one can conclude that application of selective mode excitation could really lead to substantial improvement of system data security.

4. Conclusion

The presented materials emphasize advantages of application of selective mode excitation that lead to both increasing the system information capacity and enhancing data security. Realizability of three-stage hierarchical scheme of data compression is shown, and also ability of the mentioned technique to embarrass eavesdropping is highlighted. Application of selective mode excitation in the form of MDM technique could improve significantly performances of fiber systems, at least the ones like short- and middle-haul communication lines and LANs.

Author details

Dmitry V. Svistunov

Address all correspondence to: svistunov@mail.ru

Peter-the-Great St.-Petersburg Polytechnic University, St.-Petersburg, Russia

References

- [1] Tur M, Menashe D, Japha Y, Danziger Y. High-order mode based dispersion compensating modules using spatial mode conversion. *Journal of Optical Fiber Communications Reports*. 2007;**4**(2):110-172. DOI: 10.1007/s10297-007-0081-0
- [2] Salsi M, Koebele C, Sperti D, Tran P, Mardoyan H, Brindel P, Bigo S, Boutin A, Verluise F, Sillard P, Bigot-Astruc M, Provost L, Charlet G. Mode-division multiplexing of 2×100 Gb/s channels using an LCOS based spatial modulator. *Journal of Lighthwave Technology*. 2012;**30**(4):618-623. DOI: 10.1109/JLT.2011.2178394
- [3] Hu T, Li J, Ren F, Tang R, Yu J, Mo Q, Ke Y, Du C, Liu Z, He Y, Li Z, Chen Z. Demonstration of bidirectional PON based on mode division multiplexing. *IEEE Photonics Technology Letters*. 2016;**28**(11):1201-1204. DOI: 10.1109/LPT.2016.2530663
- [4] Kawaguchi Y, Tsutsumi K. Mode multiplexing and demultiplexing devices using multimode interference couplers. *Electronic Letters*. 2002;**38**(25):1701-1702. DOI: 10.1049/el:20021154
- [5] Lee BT, Shin SY. Mode-order converter in a multimode waveguide. *Optical Letters*. 2003;**28**(18):1660-1662. DOI: 10.1364/OL.28.001660
- [6] Karpeev SV, Paveleyev VS, Khonina SN, Kazanskiy NL, Gavrilov AV, Eroolov VA. Fibre sensors based on transverse mode selection. *Journal of Modern Optics*. 2007;**54**(6):833-844. DOI: 10.1080/09500340601066125

- [7] Carpenter J, Thomsen BC, Wilkinson TD. Degenerate mode-group division multiplexing. *Journal of Lightwave Technology*. 2012;**30**(24):3946-3952. DOI: 10.1109/JLT.2012.2206562
- [8] Koonen AMJ, Chen H, Boom HPA, Raz O. Silicon photonic integrated mode multiplexer and demultiplexer. *IEEE Photonics Technology Letters*. 2012;**24**(21):1961-1964. DOI: 10.1109/LPT.2012.2219304
- [9] Love JD, Riesen N. Mode-selective couplers for few-mode optical fiber networks. *Optical Letters*. 2012;**37**(19):3990-3992. DOI: 10.1364/OL.37.003990
- [10] Li A, Chen X, Al Almin A, Shieh W. Fused fiber mode couplers for few-mode transmission. *Photonics Technology Letters*. 2012;**24**(21):1953-1956. DOI: 10.1109/LPT.2012.2218803
- [11] Vaissie L, Johnson EG. Selective mode excitation by non-axial evanescent coupling for bandwidth enhancement of multimode fiber links. *Optical Engineering*. 2002;**41**(8):1821-1828. DOI: 10.1117/1.1488607
- [12] Hoyningen-Huene J, Ryf R, Winzer P. LCoS-based mode shaper for few-mode fiber. *Optics Express*. 2013;**21**(15):18097-18110. DOI: 10.1364/OE.21.018097
- [13] Chen W, Wang W, Yang J. Mode multi/demultiplexer based on cascaded asymmetric Y junctions. *Optics Express*. 2013;**21**(21):25113-25119. DOI: 10.1364/OE.21.025113
- [14] Tsekrekos CP, Syvridis D. Symmetric few-mode fiber couplers as the key component for broadband mode multiplexing. *Journal of Lightwave Technology*. 2014;**32**(14):2461-2467. DOI: 10.1109/JLT.2014.2327479
- [15] Igarashi K, Souma D, Tsuritani T, Morita I. Selective mode multiplexer based on phase plates and Mach-Zehnder interferometer with image inversion function. *Optics Express*. 2015;**23**(1):183-194. DOI: 10.1364/OE.23.000183
- [16] Dong J, Chiang KS, Jin W. Compact three-dimensional polymer waveguide mode multiplexer. *Journal of Lightwave Technology*. 2015;**33**(22):4580-4588. DOI: 10.1109/JLT.2015.2478961
- [17] Svistunov DV. A planar prism for detection and selective excitation of modes in a multimode channel waveguide. *Technical Physics Letters*. 2004;**30**(4):332-334. DOI: 10.1134/1.1748616
- [18] Svistunov DV. Selective mode launching in a multimode channel waveguide by planar coupler. *Journal of Optics A Pure Applied Optics*. 2004;**6**(9):859-861. DOI: 10.1088/1464-4258/6/9/007
- [19] Svistunov DV. Evaluating the possibility of using mode compression in a cascade system for data compression in multimode fiber-optic communication lines. *Journal of Optics Technology*. 2012;**79**(1):29-35. DOI: 10.1364/JOT.79.000029
- [20] Svistunov DV. Cascade scheme of data compression in multimode fiber systems. In: Simmons M, editor. *Network Coding and Data Compression: Theory, Applications and Challenges*. New York: Nova Science; 2015. pp. 151-161. ISBN: 978-1-63483-185-7

- [21] Asawa CK. Intrusion-alarmed fiber optic communication link using a planar waveguide bimodal launcher. *Journal of Lightwave Technology*. 2002;**20**(1):10-18. DOI: 10.1109/50.974813
- [22] Lecoy P. *Fiber-Optic Communications*. London-Hoboken: ISTE-Wiley; 2008. p. 333. ISBN: 978-1-84821-049-3
- [23] Olshansky R, Keck DB. Pulse broadening in graded-index optical fibers. *Applied Optics*. 1976;**15**(2):483-491. DOI: 10.1364/AO.15.000483