

 Open access • Journal Article • DOI:10.1080/05698196608972150

Self-lubricating composites of porous nickel and nickel-chromium alloy impregnated with barium fluoride - calcium fluoride eutectic — [Source link](#)

Harold E. Sliney

Institutions: Glenn Research Center

Published on: 01 Jan 1966 - Tribology Transactions (Taylor & Francis Group)

Topics: Fluoride, Barium fluoride, Eutectic system, Chromium Alloys and Barium

Related papers:

- [Fluoride Solid Lubricants for Extreme Temperatures and Corrosive Environments](#)
- [Solid lubricant materials for high temperatures—a review](#)
- [Tribological Properties of PM212: A High-Temperature, Self-Lubricating, Powder Metallurgy Composite](#)
- [Lubricating Properties of Ceramic-Bonded Calcium Fluoride Coatings on Nickel-Base Alloys from 75 to 1900 deg F](#)
- [Effect of Sliding Velocity on Friction Properties and Endurance Life of Bonded Lead Monoxide Coatings at Temperatures up to 1250 Deg F](#)

Share this paper:    

View more about this paper here: <https://typeset.io/papers/self-lubricating-composites-of-porous-nickel-and-nickel-4910v58nz6>

NASA TECHNICAL NOTE



NASA TN D-3484

c 1

NASA TN D-3484

LOAN COPY: RETURN
AFWL (WLIL-2)
KIRTLAND AFB, N M

0130394



TECH LIBRARY KAFB, NM

SELF-LUBRICATING COMPOSITES OF
POROUS NICKEL AND NICKEL-CHROMIUM
ALLOY IMPREGNATED WITH BARIUM
FLUORIDE - CALCIUM FLUORIDE EUTECTIC

by Harold E. Sliney
Lewis Research Center
Cleveland, Ohio

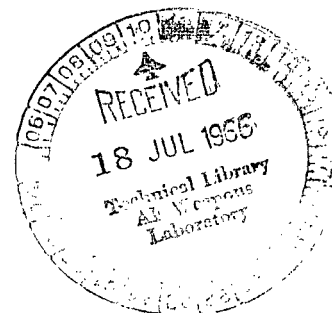



SELF-LUBRICATING COMPOSITES OF POROUS NICKEL AND NICKEL-
CHROMIUM ALLOY IMPREGNATED WITH BARIUM FLUORIDE - CALCIUM
FLUORIDE EUTECTIC

By Harold E. Sliney

Lewis Research Center
Cleveland, Ohio

NATIONAL AERONAUTICS AND SPACE ADMINISTRATION

For sale by the Clearinghouse for Federal Scientific and Technical Information
Springfield, Virginia 22151 - Price \$1.00

SELF-LUBRICATING COMPOSITES OF POROUS NICKEL AND NICKEL-CHROMIUM ALLOY IMPREGNATED WITH BARIUM FLUORIDE - CALCIUM FLUORIDE EUTECTIC*

by Harold E. Sliney
Lewis Research Center

SUMMARY

Self-lubricating composites were prepared by vacuum-impregnating porous nickel or Inconel X-750 (nickel-chromium alloy) with a barium fluoride - calcium fluoride eutectic composition. Density measurements and photomicrographs of the resulting composite structures demonstrated that this process completely filled the voids of the porous metals with the fluoride eutectic.

The compressive yield strength of the nickel composites was quite low (about 30 000 psi); therefore, in order to avoid severe plastic deformation during the friction and wear experiments, it was necessary to employ moderate contact stresses. However, alloy composites were comparatively resistant to plastic deformation; the compressive yield strength was 78 000 pounds per square inch or about 75 percent of the strength of the age-hardened alloy in the dense, wrought form.

In air at moderate contact stresses, the friction and wear properties of nickel composites were only slightly inferior to those of the alloy composites. Oxidation of nickel composites becomes serious at 1200⁰ F, however, and limits the usefulness of this material in air to a maximum temperature of about 1100⁰ F. The corresponding temperature limitation of the alloy composites in air was about 1350⁰ F. In a hydrogen atmosphere, the alloy composites performed satisfactorily to 1500⁰ F and may be suitable to somewhat higher temperatures.

The frictional properties of the composites were significantly improved by the application of a thin, sintered coating of the eutectic fluoride to the bearing surfaces of the composites.

* Presented at the Annual Meeting of the American Society of Lubrication Engineers, Pittsburgh (Pa), May 2-5, 1966.

INTRODUCTION

In recent years, solid lubricants have become widely accepted for use in many lubrication problem areas. They can be used at extreme temperatures (refs. 1 and 2), at very high loads (ref. 3), or in chemically reactive environments (ref. 2) where conventional fluid lubricants may not be suitable.

Solid lubricants are most frequently used as coatings or dry films bonded to suitably pretreated metal substrates. Very low wear rates and friction coefficients, within a range of 0.05 to 0.20, are commonly observed for sliding surfaces lubricated with dry film lubricants. Solid lubricant coatings that have adequate durability to be acceptable for many applications are available; because of the sliding contact, however, some coating wear is unavoidable. When the coating wears through, metal-to-metal contact occurs, and severe damage to the unprotected bearing surfaces can rapidly occur.

One way to increase wear life is to incorporate the solid lubricant into a composite bearing material. In composites, the solid lubricant is dispersed throughout a supporting material, such as a sintered metal structure. As wear takes place, more solid lubricant is exposed and becomes available to the sliding surfaces.

Composite bearing materials are commonly prepared by powder metallurgy techniques such as hot pressing. Self-lubricating composites prepared by hot pressing include molybdenum disulfide (MoS_2) and silver (ref. 4), PTFE, molybdenum diselenide (MoSe_2) with silver or copper (ref. 5), and MoS_2 with a metal matrix of iron and platinum (ref. 6).

A disadvantage of composites prepared entirely by hot pressing or sintering of pre-mixed powders of the lubricant and the metal is their somewhat limited mechanical strength. When metal and solid lubricant powders are mixed prior to compaction, particles of lubricant will occupy (and thus interfere with) some of the potential sites for bonding between metal particles. Furthermore, it is difficult to prepare a nonporous body by hot pressing or sintering. One method of obtaining dense, strong composites is to prepare a porous, sintered metal structure, which is subsequently impregnated with a molten material (ref. 7). As an example, seal materials for application temperatures above the limits of elastomers ($\sim 450^\circ \text{F}$) have been prepared by sintering of stainless-steel fibers in hydrogen, followed by vacuum impregnation of the sintered steel skeleton with molten silver (ref. 8).

The objective of the research described in this report was to prepare and to investigate the lubricating properties of composite materials that could be used for high-temperature sliding applications in either air or reducing environments such as hydrogen. The composites consisted of a porous metal matrix impregnated with a barium fluoride - calcium fluoride eutectic composition. In previous studies (refs. 1 and 2) bonded coatings of this eutectic had shown promise for lubrication in severe environments such as

liquid sodium, liquid fluorine, air (to 1200° F), and hydrogen (to 1500° F).

Porous nickel and sintered Inconel X-750 (nickel-chromium alloy) were vacuum-impregnated with the molten fluoride. Friction and wear of the composites were determined in air and in dry hydrogen at temperatures from 80° to 1500° F at a sliding velocity of 2000 feet per minute. The influence of sliding velocity on friction was also determined. Approximate elastic moduli and compressive yield strength of the filled and unfilled specimens were determined.

APPARATUS AND PROCEDURE

Mechanical Strength Determinations

The compressive stress-strain properties of the composite materials were determined with a standard table model universal testing instrument. The specimens were cylindrical pins, 1/2-inch long by 1/8-inch diameter. The ends were carefully machined flat and square with the cylindrical axis to minimize errors due to nonuniform end loading. Before the specimens were compressed, calibration runs to determine the deflection characteristics of the instrument were made. This was done by bringing the flat, compression platens of the instrument into contact and recording a load-deflection curve for the instrument. (The platens are equipped with a self-aligning device to ensure uniform stress over the entire area of the contacting surfaces.) The stress-strain curves for the specimens were then determined. The true compression of the specimen at any given load was obtained by subtracting the previously determined instrument deflection from the total indicated deflection at that load. The stress-strain curve for the specimen could then be constructed from the corrected values. The modulus of elasticity was obtained from the slope of the corrected stress-strain curve below the elastic limit. The yield strengths reported are at the standard 0.2 percent offset. These yield strengths were obtained in the customary manner; a line was drawn parallel to the linear portion of the stress-strain curve and offset from it by a displacement equivalent to 0.2 percent of the specimen length (0.001 in. in this case). The stress value at which the constructed line intersected the stress-strain curve beyond the elastic limit was then taken as the yield strength. A strain rate of 0.002 inch per minute was used for determination of elastic modulus and yield strength. Fracture strengths were determined at a strain rate of 0.020 inch per minute.

Preparation of Composite Materials

Porous nickel specimens of 50 and 60 percent density were obtained from a commer-

cial source. This material has a foam-like structure. Porous nickel-chromium-alloy disks were prepared by a standard powder metallurgy technique from -100 mesh powders of Inconel X-750. The powder was hydrostatically pressed at 20 000 pounds per square inch and sintered in hydrogen for 1 hour at 2150⁰ F. This treatment resulted in a powder metallurgy body of about 65 percent density with typical pore diameters of 25 to 35 microns.

Both metals were infiltrated with barium fluoride - calcium fluoride (BaF₂-CaF₂) eutectic by vacuum impregnation at 2000⁰ F. The procedure was as follows: the porous metal specimen was placed in a metal container with an amount of powdered fluoride salt in excess of that required to fill completely the voids in the porous metal and sufficient to keep the specimen completely submerged after the salt melts. The container was placed in a metal chamber, which was sealed and then evacuated to a pressure of about 1 micron. The chamber was induction-heated to 2000⁰ F to melt the fluoride, which then infiltrated into the porous metal by capillary action. In order to minimize evaporation of the molten fluoride, chamber pressures below 1 micron were avoided. As a precautionary measure, in case capillary forces were not sufficient to ensure complete impregnation of the metal, argon or nitrogen was introduced at a pressure of about 10 pounds per square inch to force the molten fluorides into any remaining voids.

The specimens were cooled under inert gas pressure, removed from the container, and wet sanded to remove excess fluoride adhering to the specimens.

In some cases, specimens were then spray-coated with 0.001 inch of fluoride eutectic. The spraying procedure is described in reference 2. After spraying, the specimens were fired in hydrogen at 1750⁰ F for 10 minutes. This temperature is below the eutectic melting point (1872⁰ F) to avoid loss of the fluoride infiltrant, but it is high enough to cause sintering of the fluoride particles in the coating and, thereby, establish the necessary bond.

Friction Apparatus and Experimental Procedure

The friction apparatus is shown in figure 1. The friction specimens consist of a rotating disk in sliding contact with a hemispherically tipped rider (3/16- or 7/8-in. radius) under a normal load of 500 grams. The rider slides on a 2-inch-diameter wear track on the disk. Sliding is unidirectional, and the sliding velocity can be varied continuously and controlled closely over a range of 200 to 2500 feet per minute. The specimens are heated by an induction coil around the disk specimen. The temperature is monitored by an infrared pyrometer capable of indicating surface temperatures from about 200⁰ to over 4000⁰ F. Suitable corrections are made for emissivity of the specimen and for infrared absorption of the viewing window by prior calibration of the pyrom-

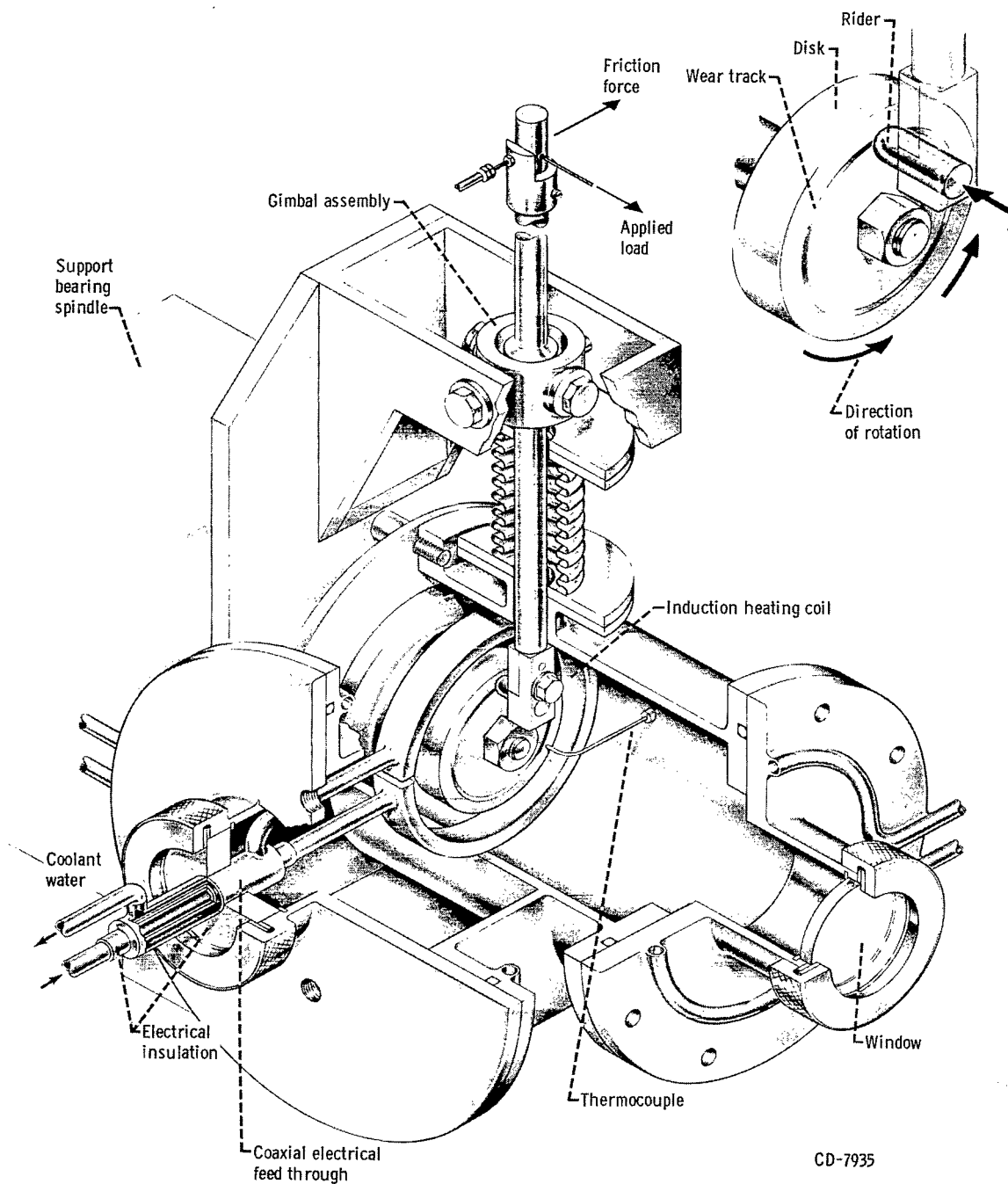

Figure 1. - High-temperature friction apparatus.

eter against a thermocouple welded to a stationary dummy disk mounted in place of a friction disk. Target diameter for the pyrometer is 1/8 inch at a distance of 6 inches. Surface temperature is monitored on the wear track, 90 degrees ahead of the point of contact between rider and disk.

Before each experiment, the rider specimen was cleaned with acetone and ethyl alcohol and scrubbed with a paste of levigated aluminum oxide and water. The rider was then rinsed with distilled water and dried. The disks were cleaned only with acetone and alcohol to avoid the possibility of embedding aluminum oxide in the surface of the composite material.

Rider and disk wear volumes were calculated from weight losses of the specimen and the known densities of the materials. If weight changes not attributable to wear (such as weight increase due to oxidation in high-temperature air experiments) were likely, wear

TABLE I. - NOMINAL CHEMICAL COMPOSITIONS AND MELTING RANGES
OF MATERIALS USED

	Cast Inconel	Inconel X-750 (powder for composites)	René 41 (coating sub- strate alloy)	BaF ₂ -CaF ₂ filler
	Composition, weight percent			
Material				
Ni	68.50	Balance	Balance	----
Co	-----	-----	11.00	----
Cr	15.50	15.00	19.00	----
Fe	9.00	7.00	5.00	----
C	.20	.05	.10	----
Si	1.60	.40	.50	----
Mo	-----	-----	10.00	----
Al	-----	.75	1.50	----
Mn	1.00	.50	.10	----
Cu	.50	.05	-----	----
Nb	2.00	.90	-----	----
Ti	-----	2.50	3.00	----
S	-----	.007	-----	----
Barium fluoride	-----	-----	-----	62
Calcium fluoride	-----	-----	-----	38
Rockwell hardness				
As cast	B-90	-----	-----	----
Aged (dense form)	-----	C-38	C-40	----
Melting point, °F	2500 to 2550	2540 to 2600	~2500	1872
Reference	9	10	9	2

TABLE II. - PHYSICAL AND APPROXIMATE COMPRESSIVE STRENGTH PROPERTIES OF MATERIALS USED^a

Material	Dense nickel ^b	Porous nickel	Nickel composite ^c	Dense Inconel X-750 ^b	Sintered Inconel	Inconel X-750 composite ^d
Condition	Annealed	-----	Vacuum-impregnated	Age-hardened	As-sintered	Vacuum-impregnated
Density g/cu cm percent of theoretical	8.90 100	4.75 53.5	^e 6.57 97.6	8.25 100	5.75 69.6	^e 6.90 100
Yield strength at 0.2 percent offset, psi	12×10 ³ to 25×10 ³ (tensile)	4.3×10 ³ to 5.2×10 ³	21×10 ³ to 36×10 ³	92×10 ³ to 119×10 ³ (tensile)	12×10 ³ to 19×10 ³	78×10 ³ to 80×10 ³
Ultimate fracture strength, psi	50×10 ³ to 60×10 ³ (tensile)	11×10 ³	50×10 ³	162×10 ³ to 179×10 ³ (tensile)	45×10 ³	>83×10 ³
Elastic modulus, psi	30×10 ⁶ (tensile)	1.8×10 ⁶ to 2.2×10 ⁶	10×10 ⁶ to 15×10 ⁶	31×10 ⁶ (tensile)	8.2×10 ⁶ to 9.6×10 ⁶	19×10 ⁶ to 21×10 ⁶
Hardness Rockwell 15 T (superficial hardness) Equivalent standard Rockwell	77 B-55	15 (f)	76 B-54	94 C-38	35 (f)	86 B-82

^aData for mechanical compressive properties are the range of values obtained in two to four determinations for each material.

^bData from refs. 9 and 10.

^c53.5 Volume percent nickel; balance BaF₂-CaF₂ eutectic.

^d66.5 Volume percent Inconel X-750; balance BaF₂-CaF₂ eutectic.

^eDensity of eutectic fluoride impregnant, 4.21 g/cu cm.

^fBelow range of Rockwell B scale.

volumes of the riders were calculated from the diameter of the wear scars and the known hemispherical radius. Disk wear volumes were determined by recording the surface profile across the wear track, determining its cross-sectional area, and multiplying the area by the average circumference of the track. The weight loss method correlates well with the other methods for unoxidized specimens.

Chemical compositions and melting ranges of the materials used in this study are given in table I.

RESULTS AND DISCUSSION

Mechanical Strength Properties

The compressive mechanical strength properties of unfilled porous nickel, Inconel X-750 (nickel-chromium alloy), and fluoride-metal composites were determined, and the results are given in table II. For comparison, published tensile data (refs. 9 and 10) for dense nickel and the dense nickel-chromium alloy are included. The properties measured were yield strength (at 0.2 percent offset), fracture strength, and elastic modulus (all in compression). The data for the experimental materials given in table II are the ranges of values obtained in two to four determinations with each material. The data for nickel and Inconel X-750 are the ranges of values found in references 9 and 10. In this discussion, the average values will be used.

The yield strength of porous nickel (53.5 percent density) was 4800 pounds per square inch compared with the reported yield strength of 19 000 pounds per square inch for annealed, dense nickel. Impregnation of porous nickel with $\text{BaF}_2\text{-CaF}_2$ eutectic increased the yield strength to 29 000 pounds per square inch. The compressive fracture strength of the composites was 50 000 pounds per square inch. The considerable difference between the yield strength and the fracture strength demonstrates that, in spite of the relatively brittle nature of the fluoride eutectic at room temperature, the nickel composite was capable of appreciable plastic deformation prior to fracture. The average elastic modulus of the nickel composites was 12×10^6 pounds per square inch or about four-tenths that of dense nickel.

The effects of the fluoride impregnant on the properties of the nickel-chromium porous material were similar. As might be expected, however, alloy composites were much stronger than nickel composites. The yield strength was 79 000 pounds per square inch or about 75 percent of the yield strength of the age-hardened, dense alloy. The fracture strength was greater than 83 000 pounds per square inch, which was the maximum stress attainable on 1/8-inch-diameter specimens with the small test machine used in these studies. The elastic modulus was 20×10^6 pounds per square inch or about two-

thirds the elastic modulus of the dense metal.

Brittle materials are characteristically stronger in compression than in tension; therefore, the compressive strengths of the composites, which contain a relatively brittle fluoride phase at room temperature, may be considerably higher than the corresponding tensile strengths. However, for ductile, nonporous metals, the modulus of elasticity and the yield strength are about the same in either tension or compression (refs. 11 and 12). Therefore, the tensile properties given in table II for nickel and the nickel-chromium alloy should be approximately equivalent to their compressive strength properties. (An exception is fracture strength. Ductile materials often deform plastically without fracture when subjected to compressive stresses.)

Nickel Composites

The first composites studied in this program were prepared by vacuum impregnation of 50-percent-dense nickel with BaF_2 - CaF_2 eutectic. A photomicrograph of the resulting structure is shown in figure 2. Under dark field illumination, the metallic phase appears dark and the fluorides are white. No unfilled pores are detectable. The magnitude of weight increase after impregnation indicates that the composite density was within 97 to 100 percent of theoretical.

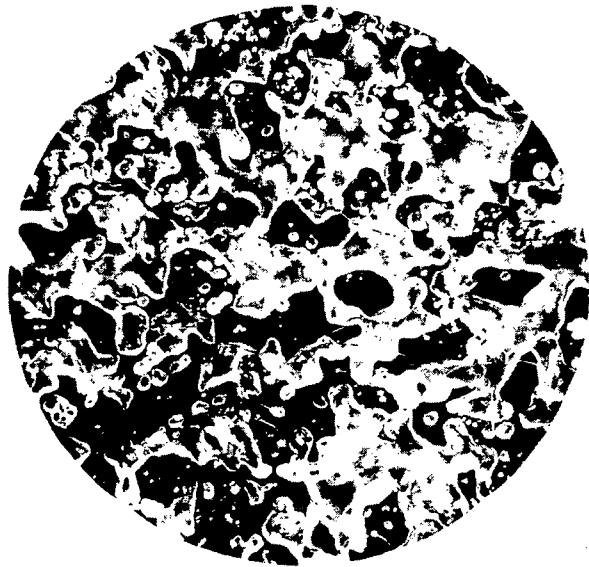

0.010 in.

C-66-1631

Figure 2. - Photomicrograph of fluoride plus nickel composite material. 50 Volume percent barium fluoride - calcium fluoride eutectic and 50 volume percent nickel. Prepared by electropolishing and dark field illumination. White areas, fluoride; black areas, nickel.

Effect of rider geometry and composition on friction and wear. - All experiments in this series were in air and were conducted under the following conditions: 1000^o F, 500-gram load, 2000-feet-per-minute sliding velocity. The numerical results are given in table III. When an extremely hard tungsten carbide rider with a 3/16-inch hemispherical radius was used, no rider wear was detectable after 1 hour. However, the wear track on the composite disk material was deeply grooved. A cross section through the track and along a disk radius is shown in figure 3(a). It was apparent that the groove was caused primarily by plastic deformation of the composite because (1) the disk weight loss was not sufficient to account for the volume of material

TABLE III. - LUBRICATING PROPERTIES OF NICKEL COMPOSITES; EFFECTS OF RIDER PARAMETERS AND
OF PRECOATING COMPOSITES

[Atmosphere, air; temperature, 1000° F; sliding velocity, 2000 ft/min; load 500 g.]

Rider radius of contact hemisphere, in.	Rider composition		Disk composition		Range of friction coefficient during first hour (229 200 cycles)	Wear rate of rider, cu in./hr	Wear rate of composite disk material, cu in./hr	Total wear rate, cu in./hr
	Material	Volume percent	Material	Volume percent				
3/16	Cobalt-bonded tungsten carbide	---	Nickel BaF ₂ -CaF ₂ eutectic	50 50	0.15 to 0.20	Less than 10 ⁻⁷	Severe plastic deformation	-----
3/16	Inconel Calcium fluoride	80 20	Nickel BaF ₂ -CaF ₂ eutectic	50 50	0.15 to 0.20	10 ⁻⁵	Severe plastic deformation	-----
3/16	Nickel BaF ₂ -CaF ₂ eutectic	50 50	Nickel BaF ₂ -CaF ₂ eutectic	50 50	0.15 to 0.20	3.0×10 ⁻³	1.6×10 ⁻³	4.6×10 ⁻³
7/8	Cast Inconel	---	Nickel BaF ₂ -CaF ₂ eutectic	60 40	0.20 to 0.25	2.0×10 ⁻⁶	2.2×10 ⁻³	2.2×10 ⁻³
7/8	Cast Inconel	---	Nickel BaF ₂ -CaF ₂ eutectic ^a	60 40	0.04 to 0.08	6.3×10 ⁻⁷	4.5×10 ⁻⁴	4.5×10 ⁻⁴

^aAlso coated with 0.001-in. overlap of eutectic.

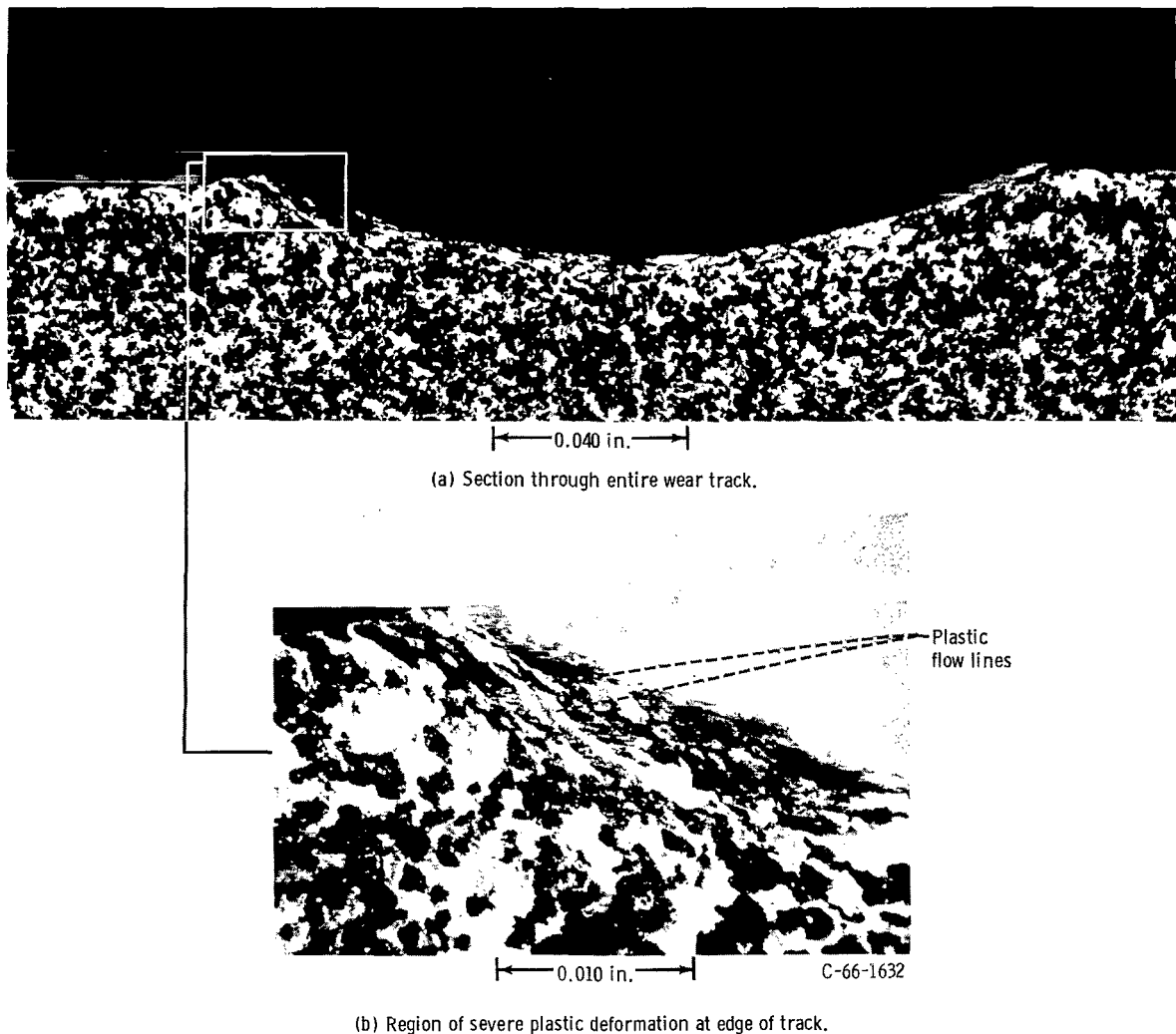

Figure 3. - Sections through wear track of 50-volume-percent-fluoride and 50-volume-percent-nickel composite showing plastic deformation caused by 3/16-inch-radius hemispherical rider. Load, 500 grams; rider material, cobalt-bonded tungsten carbide; temperature, 1000° F; sliding velocity, 2000 feet per minute; duration, 1 hour.

displaced, (2) the surface of the track is very smooth with no sign of material removal or transfer, and (3) the edges of the track (fig. 3(b)) are raised into ridges characteristic of the boundaries around plastically deformed areas. In figure 3(b), lines of plastic flow are clearly delineated by alternate bands of deformed nickel and fluoride. At temperatures considerably below 1000° F, both CaF_2 and BaF_2 are susceptible to plastic deformation (refs. 13 and 14).

When a composite rider (sintered 80 percent nickel-chromium - 20 percent CaF_2) was used, some rider wear occurred, but severe plastic deformation of the wear track on the composite disk was still evident.

When a softer composite rider (the same composite as the disk) was used, plastic

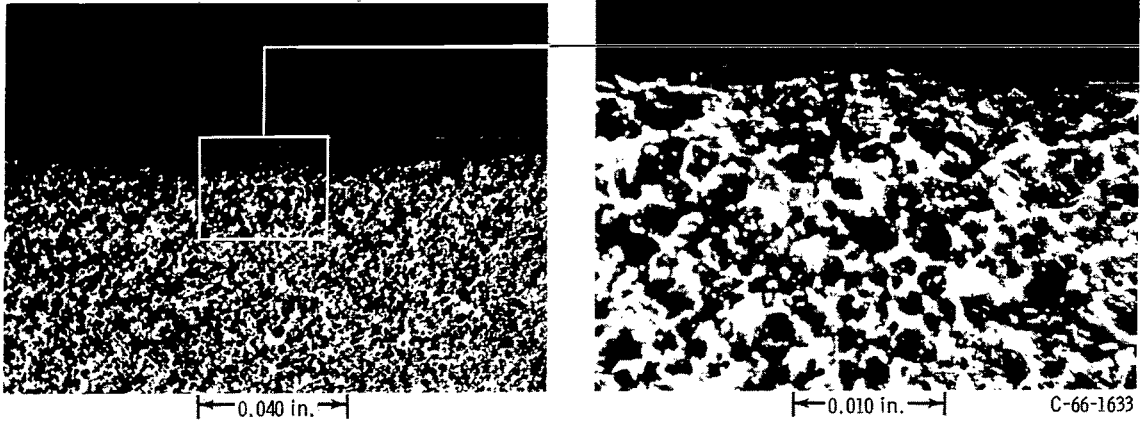

Figure 4. - Section through wear track of 40-volume-percent-fluoride and 60-volume-percent-nickel composite showing mild surface damage caused by 7/8-inch-radius hemispherical rider. Load, 500 grams; rider material, cast nickel-chromium alloy; temperature, 1000° F; sliding velocity, 2000 feet per minute; duration, 1 hour.

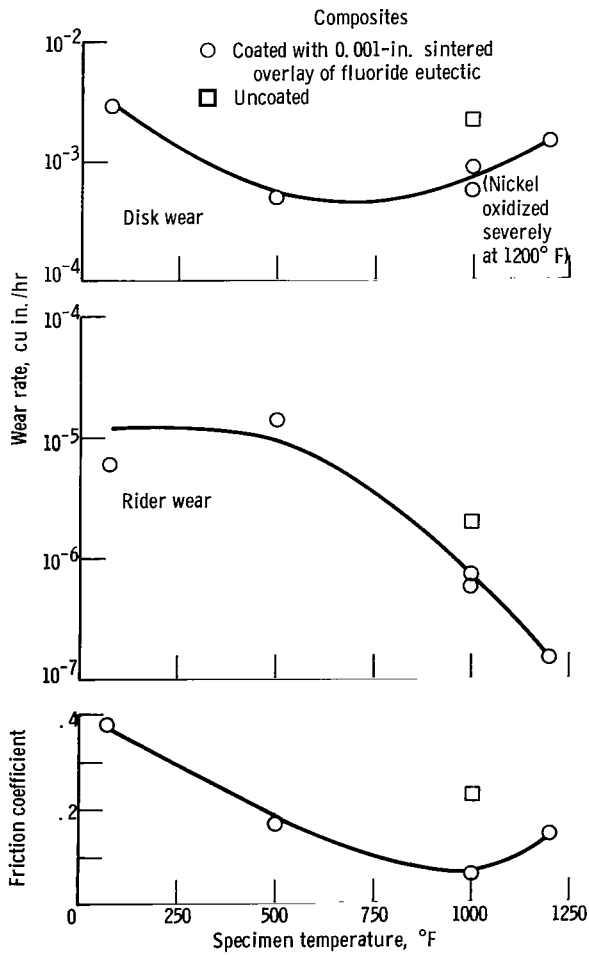

Figure 5. - Lubricating properties in air of eutectic fluoride and nickel composites. 40 Volume percent barium fluoride - calcium fluoride eutectic and 60 volume percent nickel; sliding velocity, 2000 feet per minute; load, 500 grams; specimens, nickel-chromium cast alloy riders (7/8-in. hemispherical radius) against composite disks.

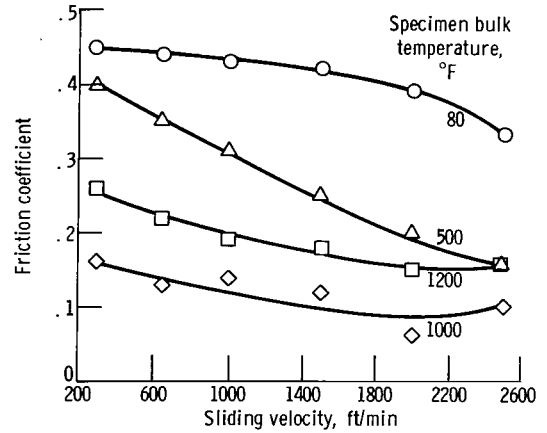

Figure 6. - Friction properties of 40-volume-percent-fluoride and 60-volume-percent-nickel composite bearing materials. Bearing surface of composite coated with 0.002-inch sintered eutectic.

deformation was not evident; rider wear was of about the same magnitude as disk wear. The friction coefficient for all three cases cited was in the range 0.15 to 0.20.

Plastic deformation of the disk was minimized by (1) increasing the radius on the hemispherical rider to 7/8 inch and thus reducing the contact stress and (2) using a denser (60 percent) nickel matrix for the composite disk. With this combination plastic deformation of the composite was reduced (fig. 4), but the friction coefficient was higher (0.20 to 0.25) (table III), possibly because of the reduced fluoride content.

The composite was then coated with a thin (0.001 in.) sintered film of BaF_2 - CaF_2 eutectic. With a 7/8-inch-radius, cast Inconel rider sliding on the coated disk, the friction coefficient was 0.04 to 0.08, and both rider and disk wear were the lowest observed in this series of experiments.

Effect of temperature and sliding velocity on self-lubricating properties. - Based on the results of the preliminary studies described in the previous section, all subsequent experiments were conducted with coated composite disks of the higher metallic content (60 percent nickel) and with 7/8-inch-radius cast alloy riders.

The influence of temperature at a constant sliding velocity (2000 ft/min) is given in figure 5. Wear was higher at 80° and 500° F than at 1000° and 1200° F, but metal transfer or other evidence of severe surface damage that might be attributable to wear was not observed at any of these temperatures. The nickel composites were, however, severely oxidized in air at 1200° F; therefore, the maximum service temperature for use in air is about 1100° F.

The influence of sliding velocity on the frictional properties at various temperatures is given in figure 6. At any given temperature, the friction coefficient tended to decrease with increasing sliding velocity. This is consistent with results obtained with oxide and other fluoride coatings (ref. 2).

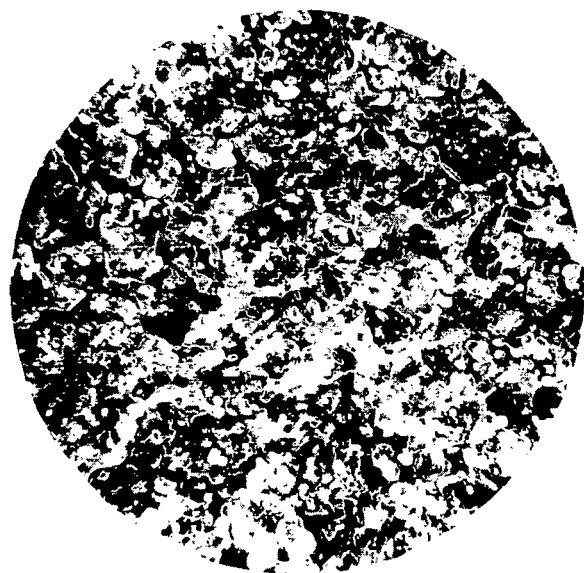

0.010 in.

C-66-1634

Figure 7. - Photomicrograph of fluoride plus sintered nickel-chromium alloy composite material. 35 Volume percent barium fluoride - calcium fluoride eutectic and 65 volume percent sintered nickel chromium alloy. Prepared by electropolishing and dark field illumination. White areas, fluoride; black areas, metal.

Nickel-Chromium Alloy Composites

Fluoride-impregnated alloy composites were studied because the alloy has higher strength (table II, p. 7) and better oxidation resistance than nickel. The composites were nominally 65-volume-percent alloy - 35-volume-

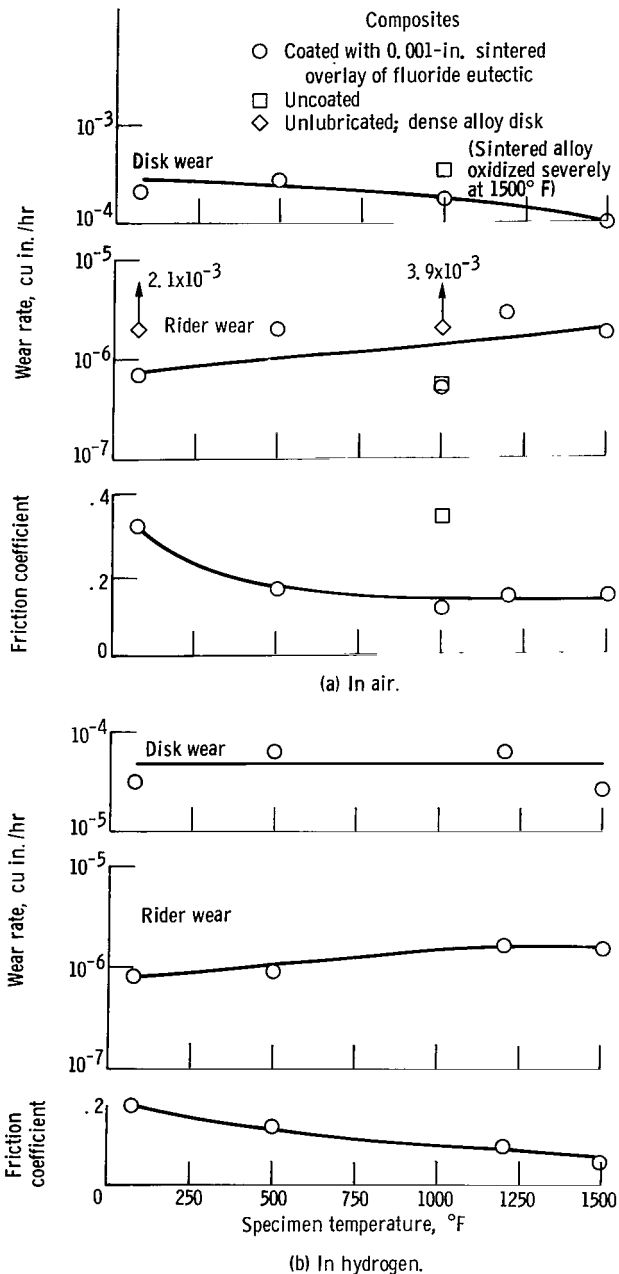

Figure 8. - Lubricating properties of eutectic fluoride and nickel-chromium alloy composites. 35 Volume percent barium fluoride - calcium fluoride eutectic and 65 volume percent sintered alloy; sliding velocity, 2000 feet per minute; load, 500 grams; specimens, nickel-chromium cast alloy riders (7/8-in. hemispherical radius) against composite disks.

percent fluoride eutectic. The microstructure (fig. 7) was similar to the nickel composites.

Friction and wear in air. - The influence of temperature on friction and wear at a sliding velocity of 2000 feet per minute is given in figure 8(a). Disk wear was lower at all temperatures for alloy composites than it had been for nickel composites. Rider wear was low at all temperatures. In contrast, rider wear against the unlubricated alloy in the dense wrought form was several hundred times higher than rider wear against the alloy composites. The friction coefficients were comparable to those observed for nickel composites. Oxidation of the alloy composites was not serious at 1200° F but was severe at 1500° F. Oxidation, therefore, limits the maximum service temperature in air to about 1350° F.

Friction and wear in hydrogen. - The lubricating properties of alloy composites in a hydrogen atmosphere are given in figure 8(b). Very low wear was observed at all temperatures; disk wear rate was nearly constant for all temperatures. Rider wear rate increased slightly with temperature. The friction coefficients were 0.20 at 80° F and gradually decreased with temperature to 0.06 at 1500° F. No deterioration of the composite occurred at 1500° F.

A common and serious limitation on high-temperature fluoride and oxide solid lubricants is poor room-temperature lubricating characteristics; therefore, the low wear rates at 80° F are perhaps as significant as the favorable high-



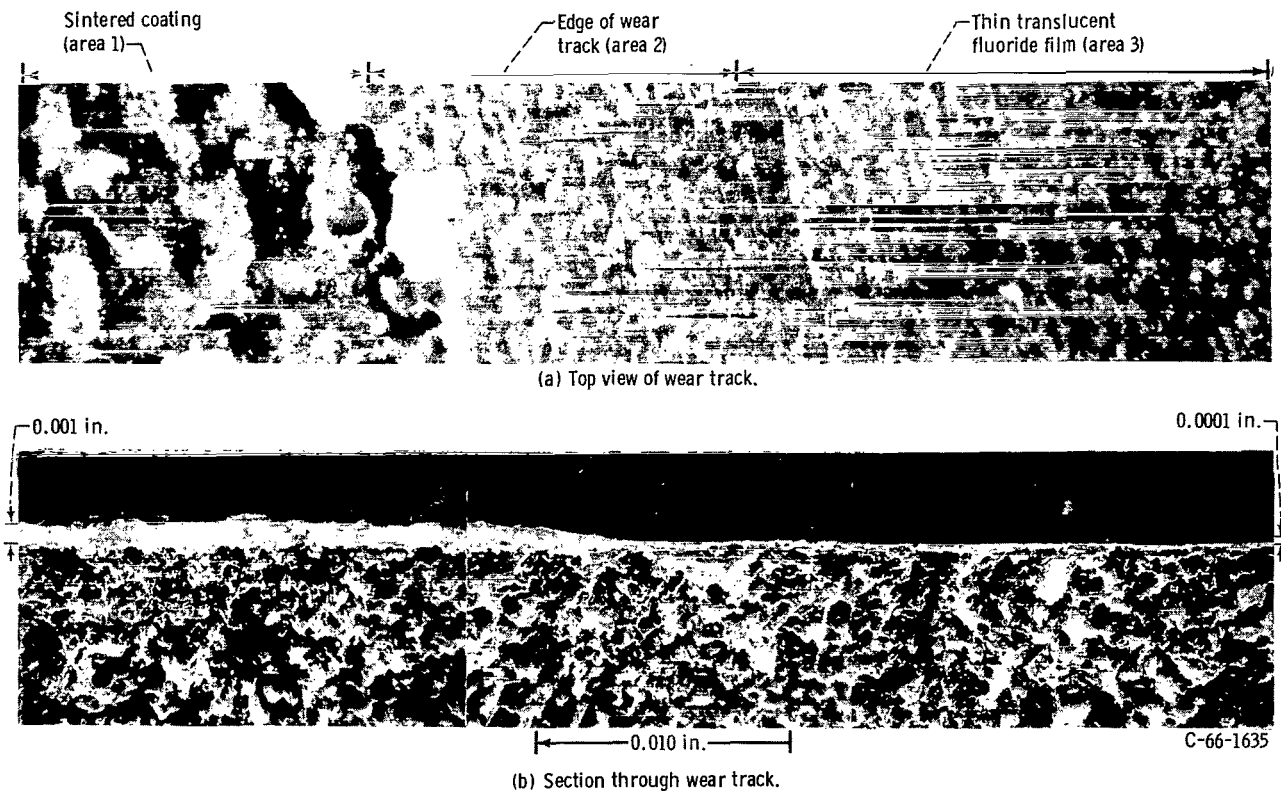

Figure 9. - Montage of wear track on 35 volume percent fluoride plus 65 volume percent alloy composite. Load, 500 grams; temperature, 1200° F (hydrogen); sliding velocity, 2000 feet per minute; duration, 6 hours; rider, 7/8-inch-radius hemisphere.

temperature properties.

Photomicrographs of the wear track on a coated 65-percent-alloy - 35-percent-fluoride composite are given in figure 9. They show the condition of the wear surfaces after a 6-hour friction and wear experiment at 1200° F and 2000 feet per minute in a hydrogen atmosphere. A plan view of the wear track and the adjacent undisturbed coating is shown in figure 9(a). The track is covered with a smooth, glazed, nearly transparent film of fluoride eutectic. A section through the wear track is shown in figure 9(b). The thickness of the sintered eutectic coating tapers off from 0.0010 inch adjacent to the track to a very thin but continuous film of about 0.0001 inch within the track. The presence of this continuous lubricating film after over 1 300 000 wear cycles demonstrates the durability of the lubricating film on the composite substrate. It can be seen that the fluoride phase in the coating is continuous with the fluoride phase in the composite structure in many regions along the bond line. This contributes to the adhesion of the coating and also increases greatly the probability that almost any area in which the coating wears through will be replenished by fluoride lubricant smeared out of the composite. Figure 10 is a section through the tip of the rider specimen that produced the wear track; a worked surface layer is evident.

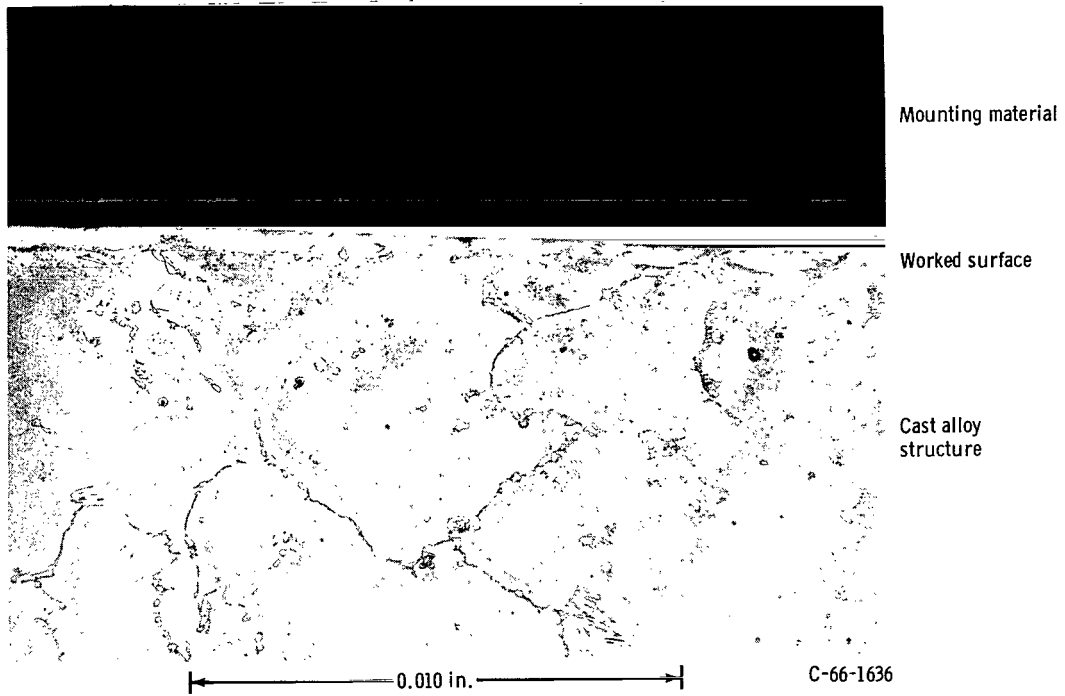

Figure 10. - Section through wear surface of rider specimen run against wear track shown in figure 9.

TABLE IV. - COMPARATIVE WEAR LIFE OF
COMPOSITES AND COATINGS IN AIR AND
HYDROGEN

Specimen temperature, °F	Air		Hydrogen	
	Composites	Coatings	Composites	Coatings
	Cycles at which friction coefficient increased to 0.30 ^a			
80	(b)	(c)	d ₁ 560 000	(c)
500	2 750 000	115 000	d ₁ 490 000	(c)
1000	1 150 000	389 000	d ₁ 610 000	275 000
1200	1 370 000	(c)	d ₁ 370 000	(c)
1500	850 000	(c)	570 000	(c)

^aBased on single runs.

^bLow wear rate but friction coefficient of 0.30 to 0.35.

^cNo test.

^dExperiments terminated before failure. (Friction coefficient did not increase to 0.3 during number of cycles indicated.)

Comparison of wear life in air and hydrogen. - The wear lives of nickel alloy composites in air and in hydrogen are given in table IV. The slider materials were (1) riders, 7/8 inch in radius, hemispherically tipped, and of a cast nickel-chromium alloy, (2) composite disks, 60 percent dense sintered nickel-chromium alloy vacuum-impregnated with BaF_2 - CaF_2 eutectic and provided with a 0.0005-inch sintered film of the same eutectic, and (3) coated dense metal disks, 0.001-inch fused coating of BaF_2 - CaF_2 eutectic on dense nickel-chromium alloy. Specimens were tested at 500-gram loads at 2000 feet per minute. Complete lubrication failure did not occur with any of the composites in the sense that a sudden large increase in wear and friction occurred. The friction coefficient characteristically was low during the first phase of the experiment. It then began to vary in a roughly periodic manner. It is probable that the increase in the friction coefficient occurred as small areas of metal were progressively exposed in the wear track, and that the decrease occurred as more fluoride lubricant was exposed by the wear process. Because no distinct lubrication failure could be determined, failure was arbitrarily taken as the time at which the friction coefficient first increased to 0.30.

In air, the endurance life of the composites exceeded 1 000 000 cycles at 500^o, 1000^o, and 1200^o F. At 80^o F, the friction coefficient is greater than 0.30 and a zero wear life is indicated. The low wear rate (fig. 8(a)) at 80^o F, however, indicates that the composite could be used at 80^o F in applications where a friction coefficient less than 0.3 is not essential. At 1500^o F, the wear life was 850 000, but severe oxidation occurred.

In hydrogen, the experiments were terminated after about 1 500 000 cycles if the friction coefficient had not yet increased to 0.30. Results were similar to those obtained in air with the exception that the friction coefficient at 80^o F was lower in hydrogen than in air and the composite ran a full 1 500 000 cycles at friction coefficients below 0.30.

At 500^o and 1000^o F, the wear life of the composite was far superior to the wear life of the fluoride coatings bonded to a dense metal substrate.

SUMMARY OF RESULTS

Self-lubricating composites of two types, porous nickel and sintered Inconel X-750 (nickel-chromium alloy), both vacuum-impregnated with barium fluoride - calcium fluoride eutectic, were studied. Friction coefficients and wear rates in air and in hydrogen were determined. The friction specimens were hemispherically tipped, cast Inconel riders in sliding contact with rotating disks of the experimental composite materials. The ranges of temperature and sliding velocities investigated were 80^o to 1500^o F and 200 to 2500 feet per minute, respectively. The principal results of this investigation were as follows:

1. Low wear rates of the cast alloy riders and of the composite disks were obtained

with both types of fluoride-metal composite. Friction coefficients were higher for the composites than for dense substrate metals lubricated by a thin coating of the same fluoride. However, the advantages of coatings (lower friction) and of composites (longer life) were obtained by coating the composite with a thin, sintered film of the same composition as the fluoride impregnant.

2. In air, the maximum useful service temperature of the nickel composite is about 1100^o F; the corresponding temperature for alloy composites is around 1350^o F. In hydrogen, alloy composites performed satisfactorily to 1500^o F and may be useful to somewhat higher temperatures.

3. The load-carrying capacity of nickel composites was severely limited by the low yield strength of the nickel matrix. The stronger alloy composites were greatly superior in resisting plastic deformation of the load-bearing surfaces.

4. It is important that fluoride-coated alloy composites exhibited low wear rates at room temperature as well as at high temperatures. This can be significant because, in many high-temperature applications, a period of low-temperature operation is required during some phase of the operating cycle.

5. In general, the aforementioned results indicate that the composite materials studied have the properties required for high-temperature bearings and seal applications. Because of their high strength, the alloy composites should be useful as retainer materials in ball bearings, as self-lubricating, sleeve bearing materials, or possibly as sliding contact seal materials. The nickel composites may be too soft for use as retainer materials, but this same property provides a degree of conformability at the contacting surfaces that may be desirable in some sliding contact seal applications.

Lewis Research Center,
National Aeronautics and Space Administration,
Cleveland, Ohio, April 14, 1966.

REFERENCES

1. Hady, W. F.; Allen, G. P.; Sliney, H. E.; and Johnson, R.: Friction, Wear, and Dynamic Seal Studies in Liquid Fluorine and Liquid Oxygen. NASA TN D-2453, 1964.
2. Sliney, Harold E.; Strom, Thomas N.; and Allen, Gordon P.: Fused Fluoride Coatings as Solid Lubricants in Liquid Sodium, Hydrogen, Vacuum, and Air. NASA TN D-2348, 1964.
3. Demorest, K. E.; and Whitaker, A. F.: Investigation of the Coefficient of Friction of Various Greases and Dry Film Lubricants at Ultra High Loads for the Saturn Hold-Down Arms. NASA TM X-53331, 1965.

4. Johnson, Robert L.; Swikert, Max A.; and Bisson, Edmond E.: Friction and Wear of Hot-Pressed Bearing Materials Containing Molybdenum Disulfide. NACA TN 2027, 1950.
5. Boes, D. J.; and Bowen, P. H.: Friction-Wear Characteristics of Self-Lubricating Composites Developed for Vacuum Service. ASLE Trans., vol. 6, no. 3, July 1963, pp. 192-200.
6. Campbell, M. E.; and Van Wyk, J. W.: Development and Evaluation of Lubricant Composite Materials. Lubrication Eng., vol. 20, no. 12, Dec. 1964, pp. 463-469.
7. Schwarzkopf, P.: Powder Metallurgy. Macmillan Co., 1947, p. 149.
8. Smith, Leon L.: Fibrous Composite Materials for Extreme Environment Seals. Lubrication Eng., vol. 20, no. 3, Mar. 1964, pp. 99-105.
9. Materials in Design Engineering, Materials Selector Issue, vol. 60, no. 5, 1964.
10. Anon.: Engineering Properties of Inconel Alloy X-750. Tech. Bull. No. T-38, The International Nickel Co., 1963.
11. Timoshenko, S.: Strength of Materials. Pt. I. Elementary Theory and Problems. D. Van Nostrand Co., Inc., 1950, p. 4.
12. Sayre, M. F.: Compression Tests. ASM Metals Handbook, Taylor Lyman, ed., 1948, pp. 109-111.
13. Liu, T. S.; and Li, C. H.: Plasticity of Barium Fluoride Single Crystals. J. Appl. Phys., 35, no. 11, Nov. 1964, pp. 3325-3330.
14. Burn, R.; and Murray, G. T.: Plasticity and Dislocation Etch Pits in CaF_2 . J. Am. Ceram. Soc., vol. 45, no. 5, May 1962, pp. 251-252.

"The aeronautical and space activities of the United States shall be conducted so as to contribute . . . to the expansion of human knowledge of phenomena in the atmosphere and space. The Administration shall provide for the widest practicable and appropriate dissemination of information concerning its activities and the results thereof."

—NATIONAL AERONAUTICS AND SPACE ACT OF 1958

NASA SCIENTIFIC AND TECHNICAL PUBLICATIONS

TECHNICAL REPORTS: Scientific and technical information considered important, complete, and a lasting contribution to existing knowledge.

TECHNICAL NOTES: Information less broad in scope but nevertheless of importance as a contribution to existing knowledge.

TECHNICAL MEMORANDUMS: Information receiving limited distribution because of preliminary data, security classification, or other reasons.

CONTRACTOR REPORTS: Technical information generated in connection with a NASA contract or grant and released under NASA auspices.

TECHNICAL TRANSLATIONS: Information published in a foreign language considered to merit NASA distribution in English.

TECHNICAL REPRINTS: Information derived from NASA activities and initially published in the form of journal articles.

SPECIAL PUBLICATIONS: Information derived from or of value to NASA activities but not necessarily reporting the results of individual NASA-programmed scientific efforts. Publications include conference proceedings, monographs, data compilations, handbooks, sourcebooks, and special bibliographies.

Details on the availability of these publications may be obtained from:

SCIENTIFIC AND TECHNICAL INFORMATION DIVISION
NATIONAL AERONAUTICS AND SPACE ADMINISTRATION
Washington, D.C. 20546