

Sensor technology innovation for the advancement of structural health monitoring: a strategic program of US-China research for the next decade

Steven D. Glaser[†]

Department of Civil and Environmental Engineering, University of California, Berkeley, CA, 94708, USA

Hui Li

School of Civil Engineering, Harbin University of Technology, P.O. Box 2546, Campus 2, Harbin, 150090 P.R. China

Ming L. Wang

University of Illinois at Chicago, Department of Civil and Materials engineering, 842 West Taylor st., Chicago, IL 60607-7023, USA

Jinping Ou

Dalian University of Technology, No.2 Linggong Road, Dalian City, 116024 P.R. China

Jerome Lynch

Department of Civil and Environmental Engineering, Department of Electrical Engineering and Computer Science, University of Michigan, Ann Arbor, MI 48109-2125, USA

(Received October 20, 2006, Accepted January 15, 2007)

1. Introduction

Integrated health monitoring of structures, made possible by advances in sensor technology, is improving structural reliability, longevity, system performance, and safety against natural hazards and intentional attack. Current technology is moving beyond the embryonic stage and is becoming able to meet the challenges associated with structural health interpretation. The US has been a driving force behind the research and development of new sensor technologies while China has been leading the international community in the deployment of sensor technologies and data interpretation methods for monitoring real civil structures. The US-China Joint Working Group was assembled to formulate a

[†]Professor, Corresponding author, E-mail: glaser@berkeley.edu

forward-looking collaborative research program in Integrated Structural Health Monitoring (SHM). This working group integrates the core strengths of the US and Chinese participants so that key challenges can be identified and strategic research plans formulated.

This paper presents the technical and programmatic vision of the working group. At present the group has formulated a comprehensive plan for accelerating the development of integrated health monitoring of critical civil structures exposed to earthquake and wind hazards. This venture will facilitate international student exchanges, accelerate technology transfer through complementary research and data exchanges, design stimulating educational courses for students, and provide training sessions for practicing engineers. Furthermore, it will actively involve relevant industrial and government agencies in activities aimed towards promoting and implementing integrated structural health monitoring. It is expected that a successful health monitoring program will result in a high-quality empirical database of structural behavior that provides a wealth of knowledge about how bridges and structures perform and deteriorate over their operational lives. Researchers accessing the database will be able to develop better design methods, more accurate long-term performance models, and create direly needed asset management/decision-making tools. All of these advances help the structural engineering profession to better quantify the value of structures as societal assets, both in terms of user costs and derived societal benefit.

Given that the task force members have major interests and expertise in civil engineering structures, it is reasonable to focus upon infrastructure systems (high-rise buildings, signature bridges, electrical distribution systems, water and wastewater systems, pipelines, communication networks, among others) and to address the questions particular to the special needs associated with health monitoring each class of constructed facility. The task force has selected five key systems that will serve as focal points for future work, as outlined in Table 1. Associated with each key system is a short list of high-impact hazards common to these structures. A fundamental component of the path forward is the development of a clear definition of what performance states of the structure will be considered operational (i.e. “healthy”) versus those that will be considered as “failed” (i.e. damaged).

Future structural health monitoring technologies will be highly dependent upon the sensors employed to measure the behavior of the structure. Today, engineers are in a good position to refine existing measurement paradigms by utilizing emerging sensor design archetypes; in particular, sensors and micro-circuitry made possible by micro electro-mechanical systems (MEMS) technology. MEMS are micron-scale mechanical devices that are “machined” out of silicon using the same processes commonly used to fabricate integrated circuits (Senturia 2003). These are often the same mechanical subassemblies that

Table 1 Key civil systems and associated hazards

Targeted Systems for Future Research	Key Hazards
Signature bridges	over-stressing, corrosion, fatigue, wind/rain vibration, earthquake, intentional damage, breakage of cables, uneven cable force distribution
Steel high-rise structures, Large-span dome structures, Nuclear power facilities	over-stressing, corrosion, wind/snow, earthquake, intentional damage
Offshore platform structures	corrosion, fatigue, wind, earthquake, ice, wave, flow, intentional damage
Pre-cast concrete girder bridges	shear cracking, over-stressing, loss of prestress, corrosion, earthquake, intentional damage
Lifeline systems	corrosion, leakage, wind, earthquake, intentional damage
Built environment	mold, moisture, air quality, energy usage, structural integrity, fire

are part of the traditional macro-scale counterpart. Another attractive feature of MEMS is the ability to seamlessly integrate electrical and electro-mechanical components alongside the micro-machined mechanical transducer. Because the process elements and internal linkage movements are now small, MEMS-based transducers often consume very little power. The low-cost, low-power, and small size attributes of MEMS-based transducers have revolutionized what can now be measured in-situ. Perhaps the most important enabling technology for SHM has been the introduction of comprehensive miniature sensing platforms that co-locate transduction (sensing or actuation), signal processing, computational power, and wireless communication all in one miniaturized package – such wireless sensors are commonly called Motes or “smart” sensors (e.g. Glaser, *et al.* 2006, Lynch and Loh 2006, Ou, *et al.* 2005, Huang 2003, Hill, *et al.* 2000). In turn, Motes are combined into large, organic networks which allow dense, detailed sensing, thereby opening a new sensing paradigm in which the network is effectively the sensor. The paradigm of sensor networking allows engineers and scientists to move beyond the idea of a sensor as a single instrument that only measures one thing, to a comprehensive system consisting of many small nodes working cooperatively. Motes are now ubiquitous enough that several companies, large and small, are selling them commercially (e.g. Shinkawa Sensor Technologies, Dust Networks, Moteiv, Crossbow, and Microsense).

2. Synergies of a Sino-U.S. partnership

China and the United States are owners of large inventories of civil structures distributed over vast areas. Our economies are more intertwined than perhaps any other two in the world. As such, common interests exist in the effective management of national infrastructure inventories. As our economies further intertwine, the need to maintain and protect our interdependent infrastructure systems takes on even greater importance. With innovation taking place in a concurrent fashion in the two nations, many benefits can be reaped by developing stronger ties between the two SHM research communities, including acceleration of technology innovation. What better test-bed for this cooperation than protecting the infrastructure that affects the well-being of all the citizens of both countries?.

In the United States, researchers have for several decades been strong proponents of structural health monitoring (SHM) of the nation’s infrastructure systems. During this period of time, a large number of technologies and techniques, from sensor development to data processing, have been brought to fruition. Embedded systems, wireless sensor networks, and micro-sensors, have all been developed with notable contributions from American researchers. In spite of these developments, actual field implementation of SHM in US civil infrastructure is limited to only a few deployments in critical structures and bridges that have been decommissioned or severely damaged. Part of the reason for this state of affairs is that US infrastructure (bridges and buildings) owners, for political, economic and social reasons, are not yet ready to implement SHM systems.

China’s current industrialization calls for the design and construction of extensive new infrastructural systems throughout the country. Many structures, including tall buildings, long-span bridges, and stadiums, have been built with new structural design concepts or incorporating new structural systems. Chinese owners, public and private, recognize the increased safety and lower life-cycle costs derived from implementing SHM systems; they have begun to instrument many structures as a matter of course. Already, Chinese researchers are making extensive use of this present and future instrumented stock of structures to validate and improve SHM technologies. With extensive new construction likely to continue for the next decade, key structures in the early-planning stage can be chosen to serve as open

test-beds that combine the skills of both countries' researchers and contractors. Research teams assembled from U.S. and Chinese experts would have a unique opportunity which would pay major dividends in the future.

From the viewpoint of developing new knowledge and educating future generations of researchers and professionals, increased funding for SHM from national governmental sources is needed in both the United States and China. To date, funding opportunities have been largely provided to each country individually by the National Science Foundation (NSF) and the National Natural Science Foundation of China (NSFC). Although funding levels from the NSF and NSFC are small when compared to those of many mission agencies (e.g. military sources), these two organizations represent the core funding source for basic research conducted by the U.S. and Chinese SHM communities. Their continued support is necessary to ensure a successful outcome of any bi-national research program proposed. However, these agencies have shown little interest in funding the foreign portion of a bi-national research project except for a few select research areas such as physics. It is imperative that a coordinated, cooperative program be jointly developed to support and foster a bi-national program aimed towards aggressive development of basic knowledge in the proposed SHM field. Success with this bi-national program can attract common interests from mission agencies to support applications of the new technologies through applied research activities and field demonstration projects.

On the US side, the Department of Defense and Transportation, and many other mission agencies carry out in-house research in addition to providing funding to university researchers in the proposed program area. However, these agencies disproportionately allocate their external funding to industry for targeted research and development. As a result, academic researchers primarily receive their support from the NSF. The NSF has provided funding for decades so the funding climate is well known and open to all US researchers (see www.nsf.org). In China, the NSFC supports theoretical and basic research that is comprehensive and innovative. The China Engineering Academy (CEA) also hosts various-length research programs as well as performing some research in-house. However, only one civil engineering project in smart materials and systems has been supported by the CEA. Over the past five-years, the National High-Tech Research Program 863 - Technique Breakthrough (a plan supported by the Ministry of Science and Technology (MOST)) has been a strong supporter of research and development in smart sensors, structural health monitoring, and control technologies as applied to offshore oil platforms. During the same time period, the Ministry of Communication (MOC) has supported research and development of technology related to structural health monitoring, smart bridges, and tunnels, with continued support pledged for the near future. Additionally, many projects related to SHM systems that monitor the safety of structures in long-term service and those exposed to natural hazards such as bridges, dome structures, tall buildings, dams, have been supported by the MOST.

Of historical note, China and the US have been engaged in a comprehensive research collaboration in the area of earthquake engineering for many years. Agencies in China that have been involved include the CEA, the MOC, and the NSFC. Unfortunately, these joint earthquake programs have had limited success. A key problem has been the lack of a dedicated research program that is *collectively* organized by both countries. The US-China collaboration detailed herein addresses the need for *collective* trans-Pacific organization.

3. Key issues

Much of the past work on structural health monitoring has concentrated on buildings, bridges and

dams. Little attention has been paid to the development and implementation of sensors and monitoring techniques that can be used to monitor the operating conditions of lifeline systems in general. However, the monitoring of lifeline systems, including energy delivery (e.g. electricity, gas, and oil), water supply and sewage pipelines, and communication systems, is essential to ensuring reliable operation and to mitigate the high costs and efforts associated with their repair. For systems typically covering relatively large areas, data from spatially distributed sensor networks becomes necessary to reliably determine operating environments and to detect damage during or after extreme events. The scalability and expandability of sensor networks is a topic of particular importance since both attributes would ensure that owners can gradually add more sensing channels into their monitoring systems as future budgets permit.

Traditionally, SHM is performed at a global level, with a limited number of sensors distributed over a relatively large area of a structure. Such sensing systems, with gross spatial resolution, can only detect major damage conditions. The experiences of the last two or three decades have shown that global vibration characteristics of a structure are not sensitive to all but the most severe damage, which is inherently a local phenomenon. Little work has been done on sensor fusion for dense sensor networks installed in civil infrastructure systems. Part of the fusing of sensors in a comprehensive monitoring system is devising optimal sensor network architectures that provide high data throughput, supports distributed data processing, and offers seamless expandability. Additional attributes might include tight time synchronization, flexible network communication range, extreme resiliency, and security to prevent unauthorized use of data. Motes are one recent technology that has begun to encourage the community to more aggressively address the challenges associated with sensor fusion within a comprehensive SHM system.

Conventional engineering practice in SHM is replete with studies that focus on the development of either new hardware for the sensing aspect of SHM or new software for the data interrogation portion of the problem. Few studies have addressed both the hardware and software aspects of SHM in an integrated manner. The basic problem is that no sensing system has been developed with the intent of specifically addressing issues related to SHM. To date, the standard practice in the SHM community has been to adapt commercial off-the-shelf (COTS) sensing technologies to the particular proof-of-concept experiment at hand. However, our goal is to develop a comprehensive SHM system that can go beyond the laboratory and that can be realistically deployed in the field on real-world structures. The field setting necessitates that hardware be rugged and the system's operation autonomous. As a result, SHM hardware and embedded software for automation of the sensor system must be developed in an integrated fashion.

Perhaps the major challenge in health monitoring of civil engineering structures lies in developing robust damage (or condition) models. In typical mechanical and aerospace structures, damage is generally well defined (locations and symptoms) and understood (e.g. for cars, machines, airplanes, etc.); this allows sensors (sensor networks, algorithms, etc.) to be optimally developed for measuring and monitoring structural conditions and detecting damage. Conversely, for most civil engineering structures under hazard or normal (aging) conditions, there are no "equivalent" damage models. It is difficult to identify needs in sensor technology research without knowing where, under what measurement conditions, and for what kind of infrastructure we must contend with. After we know how to properly define archetypical damage states of civil structures, we will be in a stronger position to address what to measure and how to directly interpret or relate measured signals to the condition of the instrumented structure. These are some of the issues that civil engineers should address before they consult with the sensor experts.

4. Need for test-beds

Test-bed opportunities should be identified as often as possible so that unknown constraints and hurdles associated with emerging SHM technologies can be evaluated. An ideal test-bed would be used to demonstrate a complete sensing network, including robust wireless communications and long-lived power sources, all linked to a fundamental model of what constitutes damage. These test-beds should be used to tackle meaningful but solvable problems. If the network is indeed the sensor, utmost importance must be placed on putting entire networks through their paces. The researchers engaged in hardware and software development must collaborate with the stakeholders (e.g. facility owners, managers, inspectors) who will actually use the data in the course of their work.

Our technical roadmap for test-bed experimentation should ensure that damage detection and decision-making algorithms can be adequately tested. The test-bed structures identified must have the ability to demonstrate both the scientific and practical benefits of SHM. To accomplish this, performance metrics should first be defined to measure the successes and failures of each damage detection algorithm and to facilitate quantitative comparison of different techniques. It is also important to insure that the proposed performance metrics capture what the practicing engineering community cares about. For evaluation and benchmark testing of damage detection and decision-making algorithms, it is necessary to have test-beds where progressive destructive testing can be performed. Also, it should be investigated whether SHM techniques can detect incipient nonlinear damage and if the variability of the test-bed's operational and environmental conditions, such as traffic loading and ambient temperature, lead to false positive indications of damage.

Perhaps the best way to achieve these goals is to initially construct large-scale models in the laboratory. If we go directly to the field and instrument a complex structures, we will be at the whim of nature, waiting for the next earthquake or typhoon. There is an attraction to immediately monitor full-scale in-place structures, but there are fundamental reasons to focus our efforts first on large-scale laboratory testing before going to the field. After the merits and promise of hardware and software components of SHM have been shown in the laboratory, only then is it appropriate to consider deployment to field-based test-beds. To ensure that benefits associated with the field test-beds are maximized, it is important that novel sensing systems be considered throughout the design process of the structure. By strategizing during the early design stages, the sensing system can be optimized to provide empirical response data needed by researchers addressing other facets of the US-China collaboration (e.g. damage algorithms, decision support systems, and hazard mitigation).

4.1. Illustrative example – bridge test-beds

The development of structural health monitoring methods for detection of damage occurrence, location and severity has now attained some degree of maturity, but application of these techniques to guiding bridge inspection, maintenance and management is still in its infancy (Yanev 2003). The existing gap between health monitoring technology and traditional bridge inspection methods prevents bridge managers from directly benefiting from SHM. Bridge managers want answers to serviceability and reliability issues: (a) has the load capacity or resistance of the structure changed? (b) what is the probability of failure of individual structural members and the whole structure? (c) what preventative maintenance needs to be performed? (d) what are the chances of catastrophic failure? Quantitative indicators of these performance issues are needed to enable owners to optimally allocate resources

toward inspection, maintenance and rehabilitation of their structures.

Current SHM equipment is mostly placed on long-span bridges. However, the great percentage of structures in need of repair and monitoring are smaller bridges. Some of these structures are in locations that are not amenable to typical monitoring equipment because of electromagnetic interferences, chemical or environmental hazards, or any number of man-made or natural hazards. Test-beds should be selected to exhibit as many of these scenarios as possible. For example, test-beds as a minimum should consist of one long-span bridge over salt water, one short-span bridge in a city surrounded with electromagnetic and other forms of interference, and one mid-span bridge in a remote location with no in-situ electrical supply. The test-beds should be located in locations with harsh environments, including ones with high winds, extreme temperature changes, high heat and humidity, and acid or alkaline exposure. Bridges of different materials and ages should also be part of the test-bed.

5. Measured parameters and data interpretation

The ultimate goal of SHM is to facilitate rational decision-making regarding the safety and reliability of a structure, and proper actions to take when safety concerns are raised. Damage detection and decision-making algorithms take data collected from a monitoring system and distill out information pertaining to the structure's health state; this facilitates scheduling of maintenance, the initiation of damage repairs, and allows rational decisions to be made on structural retrofitting. Although current SHM studies are replete with the development of various damage detection algorithms or decision making tools, their applicability to real-world structures is still very much unproven at this point.

Damage algorithms and decision making should be undertaken on many scales: micro-scale damage mechanisms, local component-level damage diagnosis, and global structural condition assessment. First, the development of damage detection algorithms should be based on a fundamental and firm understanding of physics-based damage mechanisms in real structures. Defects such as cracks and delaminations initiate at the micro-scale before they manifest themselves at the macro-scale. For example, pre-crack fatigue damage produces material nonlinearity which could distort ultrasound waves traveling through the body and lead to the generation of second and higher harmonic components for a single frequency input. This phenomenon is generally referred to as acoustic nonlinearity (Cantrell 2004, Cantrell and Yost 1994).

5.1. Physics-based damage detection

Many damage detection methods attempt to identify deterioration by solving an inverse problem, which often requires the construction of analytical models or Green's functions. This is a very powerful but difficult method since analytical forms of Green's function for all but the simplest shapes do not exist. The goal of structural identification is to infer the physical characteristics of a structural system, which cannot be measured directly, through the correlation of mathematical models and experimental input/response data. Early work by researchers such as Hart and Yao (1977) and Liu and Yao (1978) inspired many researchers to investigate the application of system identification to structural health monitoring. For example, an objective function based on measurable structural quantities can be applied as a finite element model, yielding a predicted response; then an optimization problem is solved

to minimize or maximize the objective function (e.g. Friswell and Mottershead 1995, Arici and Mosalam 2006).

Use of model-based damage detection methods often lead to updating a large number of damage parameters, especially when the structure has an abundance of structural members. An example of parameter reduction in damage identification is the work of Fritzen and Bohle (1999). By means of the linear substructure approach, the authors calculated the change in the dynamic stiffness matrix associated with the damage and correlated these matrix changes with dimensionless correction parameters. The size of the parameter set was reduced from 1,080 to 9, and the selected parameters were the shell and beam elements encircling the location of the damage. One problem which may arise with this method is that parameter reduction may identify the most damage-sensitive parameters but may fail to locate the damage correctly. This method was applied to the I-40 Bridge in New Mexico which was gradually damaged at four levels, and the associated frequency response functions were used for diagnosis (Farrar, *et al.* 1994). Actual damage had to be extensive before changes in modal behavior was observed.

A critical issue for the direct physical modeling approach is the uncertainty associated with measured data and assumed numerical models. While several researchers have explicitly incorporated random uncertainties into the system identification process (Bucher, *et al.* 2003, Beck and Katafygiotis 1998, Sohn and Law 1997), such approaches are based on assumptions of randomness and therefore blind to bias errors. For example, when a sensor used in an experiment is poorly calibrated, this bias error cannot be represented properly by random uncertainty. Li, *et al.* (2006) have proposed an interval analysis-based model updating method for uncertain structures. The interval eigenvalue and eigenvector formulation is used to obtain the predictable part and associated uncertainties of structural parameters. Little work has been done to properly capture the bias errors in system identification (Moon and Aktan 2006). In summary, even 30 years after its first applications to civil structures, system identification is still widely viewed as an art, as the knowledge gap precludes systematic approaches based on quantitative assessments of the various unknown parameters. Currently, system identification is highly user-dependent with success partially defined by user decisions based on heuristics and intuition.

5.2. Data-driven damage detection

Direct dependence on analytical models can be avoided by using signal-based unsupervised learning techniques. Unsupervised learning can be applied to data not containing examples from the damaged structure, but this approach is inherently limited to level one (i.e. existence) or level two (i.e. location) damage classification, thereby identifying the presence of damage without additional information such as damage severity. These approaches include novelty/outlier analysis (Sohn, *et al.* 2006, Ruotolo and Surace 1997), statistical process control charts (Sohn, *et al.* 2000), auto-associative neural networks (Chan, *et al.* 1999), and simple hypothesis testing (Lapin 1990). These methods are demonstrated to be very effective for identifying the onset of damage growth. Although these signal-based approaches only identify the existence and location of damage, level one and two damage identification may be sufficient for many practical applications. Often, numerical simulations using an analytical model of a structure are used to augment the scarce test data associated with an undamaged structure. Signal-based supervised learning techniques include neural networks (Rytter 1997, Nakamura, *et al.* 1998, Masri, *et al.* 2000), response surface analysis (Inada, *et al.* 1999), Fisher's discriminant (Garcia and Stubbs 1997), nonlinear auto-regressive moving-average (NARMA) models (Loh and Huang 1999), genetic algorithms (Ruotolo and Surace 1997), and support vector machines (Worden and Lane 2001).

De Stefano, *et al.* (1997) used Auto-Regressive Moving-Average (ARMA) models to obtain modal parameters of a three-span bridge girder with unknown random excitation. In general, the estimation of the autoregressive (AR) and moving average (MA) coefficients in the ARMA models requires solving a complicated nonlinear optimization problem. To avoid this problem, the authors first fit an AR model to the data and computed the AR coefficients and prediction errors. Next, the authors used the prediction errors as estimates of the unknown inputs to the ARMA model. The AR and MA terms were found by means of a least squares approach. Finally, the modal properties are estimated from the ARMA model. Other examples of application of ARMA models to structural identification is work by Glaser to identify changes in seismic site response (Baise, *et al.* 2001, Baise and Glaser 2000). Lynch (2005) adopts the roots of ARX time-series models as damage sensitive indicators. Here the roots (poles) are mapped to the discrete-time complex plane where statistically significant pole migrations are correlated to structural damage.

Other multidimensional health monitoring approaches using techniques such as singular value decomposition (SVD) and principle component analysis (PCA) have been considered. Yan, *et al.* (2005) proposed a method for SHM under varying environmental and operational conditions to eliminate environmental factors. Huang, *et al.* (1998) developed a new signal processing technique known as empirical mode decomposition (EMD). The combination of EMD and the Hilbert transform is referred to as the Hilbert-Huang transform (HHT). Quek, *et al.* (2003) applied this method to detecting anomalies in beams and plates. Yang, *et al.* (2003a,b, 2004) examined measured data for a sudden change in structural stiffness, thereby detecting the time instant and location of damage by extracting spikes through EMD with an intermittency criterion.

Wavelet analysis is the breaking up of a signal (or function) into shifted and scaled versions of the original wavelet, called the mother wavelet. The term “wavelet” means a small wave; small referring to its finite length and wave referring to its oscillatory behavior. The term “mother wavelet” implies that the functions (with different regions of support) that are used in the transformation are derived from one principle function. Wavelet transforms can be used to extract local information in the time domain, and has recently emerged as a promising tool for SHM and damage detection. Cumulative damage of a structure with bilinear restoring force subjected to a real earthquake ground motion was estimated in terms of the accumulated ductility ratio, which is related to the number of spikes in the wavelet analysis results (Masuda, *et al.* 1995, Sone, *et al.* 1995). The wavelet approach for on-line detection of an abrupt stiffness loss has been studied (Demetriou and Hou 1999, Vincent, *et al.* 1999). The identification and quantification of the sudden change of stiffness of a liquefying soil was also solved using wavelets (Ching and Glaser 2003). Initiation of soil weakening in a sloped embankment could be identified, soil properties quantified, and details of kinematics along the failure surface estimated. A statistical pattern classification method based on wavelet packet transform (WPT) was developed for structural health monitoring by Sun and Chang (2004).

Genetic algorithms are methods for optimization of functions based on the random variation and selection of a population of solutions. Their advantage over traditional hill-climbing optimization algorithms is that they are capable of tackling multi-modal solution topologies that are typical to structural damage identification. The two-stage process where the result was used to locate damage initially, as described by Chiang and Lai (1999) and Moslem and Nafaspour (2002) required genetic algorithms to quantify the identified elements in the second stage. Ostachowicz, *et al.* (2002) identified the location and magnitude of an added concentrated mass on a simulated rectangular plate by using the shifts in the first four natural frequencies. A genetic algorithm was employed to overcome the problem of multiple peaks in the objective function.

5.3. Statistical models

All SHM/non-destructive evaluation (SHM/NDE) can be viewed as problems in statistical pattern recognition (Bishop 1995, Sohn, *et al.* 2001), in which a damage state of the system is inferred by comparing test data with baseline data. However, the dependence of damage diagnosis on the prior baseline data makes the field deployment of current SHM/NDE technologies extremely difficult. Subtle signal changes due to damage could be masked by larger operational and environmental variations of the in-service structure. It might also take several years of data collection before the test data corresponding to a damage case can be compared with baseline data recorded many years ago. Model-based approaches can be concise in expression and easy to interpret. Model-based approaches often use physical relationships to construct functional forms, which enables both spatial and temporal variations to be considered simultaneously. As physical models are approximations of real structures, uncertainty is introduced into the model; this fact has not been given adequate consideration in the SHM literature. This type of uncertainty often combines with uncertainty caused by operational and environmental variations, making the matching of sensors with analysis an even more challenging task. Addressing and characterizing uncertainties (e.g. model errors, measurement errors, unexpected operational and environmental variability) in these scenarios can be a key aspect for matching sensor data with analytical results (Ciloglu, *et al.* 2001).

In general, data points associated with damage manifest themselves near the tails of a baseline distribution of response data, which is generally obtained from a healthy structure. Because diagnosis is concerned with outliers potentially associated with damage, improper modeling of the tail distribution may impair the performance of SHM by misclassifying a condition state of the structure. These issues can be addressed by the use of extreme value statistics (Park and Sohn 2006, Castillo 1998).

Since SHM data collected in the field or laboratory can have as many forms as there are sensors, data fusion may be a necessary preliminary step toward more refined analysis. Challenges in the areas of data storage, organization and searching have led to the development of data mining, a revolution in statistical science over the last decade. Data mining (which is also called Knowledge-Discovery in Databases (KDD) or Knowledge-Discovery and Data Mining), is the process of automatically searching large volumes of data for patterns such as association rules (e.g. Menzies and Hu 2003, Simoff and Maher 1998); in other words, the objective is to extract high-level knowledge from low-level data. Data mining involves the identification of potentially useful and understandable patterns in this data (Simoff and Maher 1998).

Use of a Bayesian approach recently received tremendous attention due to Markov Chain-Monte Carlo (MCMC) methods, which enables an efficient computational implementation of the Bayesian approach (e.g. Ching and Glaser 2003b, Beck and Katafygiotis 1998, Sohn and Law 1997). Bayesian inference uses a numerical estimate of the degree of belief in a hypothesis before evidence has been observed and calculates a numerical estimate of the degree of belief in the hypothesis after evidence has been observed (by sensors). Nonetheless, some Bayesian statisticians believe prior probabilities can have an objective value and therefore Bayesian inference can provide an objective method of induction (Gelman 2003). Bayesian approaches in SHM will not only identify the most effective method for damage detection, diagnosis, prognosis, and decision-making, but will also facilitate the wide-spread deployment of SHM.

5.4. Effects of imperfect sensors

Because typical civil infrastructure systems are designed to last 25 to 50 years (or more), the sensors

used for continuous online SHM must operate reliably with a lifespan similar to, or preferably exceeding, that of the structure being monitored. As the number of sensors deployed for a SHM application increases, it is also likely that the sensors themselves represent a weak link in the SHM system. Hence we need to systematically and thoroughly investigate the long-term reliability, robustness, and calibration of these sensors, and develop robust algorithms that can provide a reliable damage detection capability even under malfunction of some sensing nodes of the global SHM system. Fault detection methods can be classified into online and offline methods. The offline methods include frequency and time domain fault detection methods, which have been investigated widely (e.g. Ching and Glaser 2003). Recent research (e.g. Li, *et al.* 2006, Koh, *et al.* 2005a, Koh, *et al.* 2005b) has focused on online real time fault detection methods, which rely on the analytical redundancy in the state space system to detect and isolate the sensor/actuator/structural faults, and decouple the fault from noise or make the residual robust to noises and uncertainties. The performance of a controlled system depends on the working status of a network of sensors and actuators. When some sensors/actuators fail in the system, these failed nodes must be identified and isolated in real-time. Corresponding compensation algorithms are then implemented using the remaining healthy sensors/actuators to ensure satisfactory fail-safe performance of the system. Such fault tolerant systems are of increasing importance in many branches of engineering, and there is ongoing research for faulty sensor diagnosis (Rizzoni and Min 1991).

6. Sensors concepts

In recent years a variety of technologies have blossomed which broaden our commonly held view of what is a sensor. For hundreds of years, sensors were purely mechanical devices, with sensing, data transmission, variable-manipulation, and data presentation all implemented by mechanical means. More recently, these devices have become electro-mechanical (e.g. Fraden 2003) or optic-electro-mechanical. Through micro-fabrication techniques, electro-mechanical transduction mechanisms can be combined with micro-circuitry thereby forming a micro electro-mechanical system (MEMS) sensor. The sensor is now a miniaturized version of the traditional transduction element along with substantial circuitry for signal processing and computation (Senturia 2003, Judy, *et al.* 2001).

The fundamental building blocks of structural monitoring systems are the sensing transducers. The quality and completeness of the data set collected for a given structure largely depends upon the capabilities and quality of the transducers used to record structural responses. To date, a plethora of sensor types are available for installation in civil infrastructure systems. Traditional transducers widely used in bridge and building monitoring are largely macroscopic: accelerometers (force-balance, piezoelectric, piezoresistive, piezocapacitive), linear variable displacement transducers, strain gages (metal foil, semiconductor), tilt meters, anemometers, and geophones. Many of these sensors have enjoyed decades of successful field deployments and have proven valuable for measuring static and dynamic structural responses to loading.

While the structure owner would like to directly measure structural states, this is not possible. We always are left to measure a physical quantity reflective of, or correlated to a given state. For example, sensors designed to directly measure “corrosion” or “fatigue” would provide direct insight to the durability of infrastructure systems. However, we are constrained by physics to employ analytical models correlating fatigue to measures of strain and corrosion to measures of chloride ingress or metal thickness.

6.1. MEMS sensors

The present focus in sensors and sensor systems is to make extensive use of MEMS-based devices. To date, the greatest success of MEMS has been the design and fabrication of accelerometers (e.g. Analog Devices, MEMSIC, STMicro, VTI). Other readily available MEMS-based transducers have been produced to sense parameters such as relative humidity, temperature, pressures of all types, magnetic field (compass), tilt, twist (gyroscope), and gasses such as CO, NO_x, methane, and sarin. The promise of MEMS, circa 1980, was co-located sensing, actuation, signal processing, computation, and communication based on the integrated circuit (IC) manufacturing paradigm. The reality, Circa (2007), is that there has been very limited progress toward either the systems-on-a-chip or systems-in-a-package (Dust Networks, 2006) paradigms. Dust Networks will release a Mote system-on-a-chip in 2007. Technical barriers include the fact that co-fabrication with CMOS is presently difficult, making on-chip solutions costly. For example, mixed MEMS and complementary metal oxide circuitry (CMOS) are “boutique processes,” making them quite expensive. Packaging technologies are just emerging for sensors other than inertial and optical devices. Economic issues include a lack of truly high-volume applications that would bring down costs, and a lack of industry-wide standards (Kovacs 1998).

6.2. Smart materials

The field of transducing materials has the potential to add a new array of sensing options in the coming decade. Research can be broken down into three major areas: 1) advancements in fabricating transducing or “self-sensing” materials, 2) incorporating such materials into construction elements, and 3) nanoengineered materials. Some sensing materials of particular importance include piezoelectrics (e.g. PZT, PVDF, among others). An example of self-sensing construction elements might be fiber reinforced cementitious materials and cement-based composites filled with carbon blacks (nanomaterials) that exhibit piezoresistive properties, making self-sensing strain possible (Lynch and Hou 2005, Fu and Chung 1996). However, current sensors based on self-sensing structural materials suffer from creep deformation and a strong dependence on temperature and moisture.

The development of self-sensing materials has been an area with active trans-Pacific research collaborations between U.S. and Chinese researchers. For example, researchers in the Smart Materials and Structures Laboratory at University of Houston, in conjunction with scholars from Dalian University of Technology, Harbin Institute of Technology, and Shenyang Architecture and Civil Engineering University, have developed piezoceramic-based smart aggregates for the monitoring of concrete structures. The smart aggregate is formed by embedding a water-proof piezoelectric patch with wire leads into a small concrete block. The smart aggregates are then embedded at the desired locations in the concrete structure before casting (Song, *et al.* 2004, Song, *et al.* 2005).

Intentional nanoengineering of sensing materials is another area ripe for application (Schultz 2006). For example, nano-colloids and nano-structures (e.g. carbon nanotubes) can offer opportunities to intentionally form macro-scale material properties by designing at the nano-scale (Loh, *et al.* 2006). Even bio-inspired materials, including forisomes, represent great potential for structural monitoring (Pickard, *et al.* 2006). Future advancements will focus on improving material sensing properties, as well as repackaging materials in a more useful manner. With both nations investing heavily in fundamental nanotechnology research, this promises to be an area full of exciting prospects in the near future for the US-China research collaboration.

6.3. Active sensing and power harvesting

In general, sensors designed for structural health monitoring are passive components; in other words, such sensors record the response of the system without acting directly on the structure. In contrast, “active” sensors can intentionally introduce an excitation into the structure and measure the corresponding structural response. The advantage of using active sensors for structural health monitoring is that they can be used to introduce controllable and repeatable excitations (unlike output-only systems where SHM system has no control over the structural excitation). While promising, a challenge is the lack of the ability to input a signal sufficiently strong to excite all modes of interest in a civil structure. The propagation properties of elastic waves in localized regions of thin-plate structures have been shown to be well correlated to damage (e.g. cracks, delamination), and active sensing was initially explored as an inspection technology applied to mechanical and aerospace structures (Gao and Rose 2005, Ihn and Chang 2004). In recent years, active sensing has been proposed for adoption in civil structures (Wu and Chang 2001, Park, *et al.* 2006). Most often PZT patches are employed for active sensing since this thin ceramic material can serve as both actuator and sensor. PZT active sensing has been applied to the health monitoring of cementitious structures (Popovics and Rose 1994, Wu and Chang 2001, Song, *et al.* 2004, Song, *et al.* 2005a&b), composite structures (Kessler and Spearing, 2002, Gu, *et al.* 2004) and metal structures (Giurgiutiu, *et al.* 2004, Simmers, *et al.* 2006, Park, *et al.* 2006, Staszewski, *et al.* 2004, Lin and Yuan, 2001). These approaches are now being combined with wireless Motes (e.g., Grosse, *et al.* 2006, Lynch 2004).

In addition to the PZT patch, other forms of piezoelectric materials such as PZT ceramic powder (Egusa and Iwasawa, 1998) have been implemented in active sensing. Patches shown in Fig. 1, made from two types of PZT composite, can be purchased in varying thicknesses (0.125 – 2 mm) and can be cut to many sizes (Smart Material, 2006). These patches have been used to create and measure guided waves (Dosch 1992) and have been widely used to detect structural cracks and composite delamination detection. Another novel approach to the development of piezoelectric actuators is the development of piezoelectric paint; such a material can be brushed onto any structural shape at room temperature (Zhang 2006).

As Motes become more enticing, we find there is an absence of viable power sources that would allow devices to exist in the field for a near-unlimited period. At present, battery technology offers life spans of only one or two years under the best of circumstances. A possible solution to this problem is called energy harvesting. Most work involves the use of PZT materials to harvest power from structural vibrations. For example, PZT elements, either bimorphs or encapsulated fibers, mounted to mechanically vibrating structural elements have shown the potential to recharge batteries (e.g. Roundy and Wright, 2004, Poulin, *et al.* 2004, Sodano, *et al.* 2004). Other researchers have shown the ability to successfully use solar cells to power deployable sensors (e.g. Motes) outdoors for long durations (Chung, *et al.* 2004). Pister has integrated solar cells into a single-chip Mote (Pister 2006). Current trends in the efficiencies of solar cell technology suggest that solar cells are a likely cost-effective power solution, particularly for outdoor applications (Carlstrom 2005). However, the next ten years will witness exploration of new approaches to power harvesting, offering more flexible solutions to the current power limitations of field deployed sensors.

7. Sensor transduction technology

7.1. Photogrammetric sensing systems

Deformation measurement on large-scale infrastructure, including bridges, has always been a

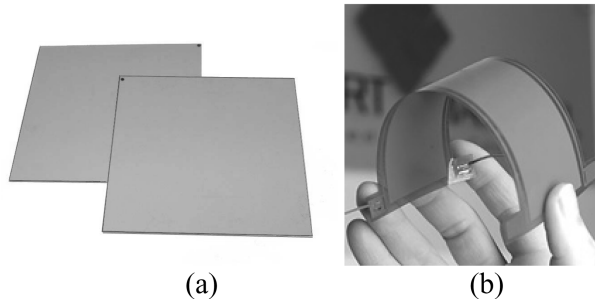

Fig. 1(a) PZT actuation element (www.piezo.com); (b) conformable PZT fiber-epoxy film actuator (<http://www.smart-material.com/>)

demanding task. Such information can be used for design validation, performance monitoring, as well as for structural safety and integrity assessment. The image resolution of new digital cameras has reached 10 million pixels with little increase in cost, opening up new areas of application for various engineering disciplines. Digital images contain two-dimensional degenerated geometrical information of three-dimensional objects. When two or more cameras are used, it is possible to reconstruct three-dimensional geometrical information of an object using triangulation. Such techniques have been used as a non-contact method to measure dynamic movements of voussoir blocks in a centrifuge (Talesnick *et al.* 2006). Other examples include three-dimensional geometry and deformation measurement, frequency and modal characteristics measurement, and automated crack detection and condition assessment. Laboratory tests have shown that sub-mm accuracy can easily be achieved using commercial cameras with 1-million pixel resolutions (Chang and Ji 2006). Targets are usually needed to provide precise correspondence in the image sequence. Optical flow techniques have been developed to obtain the velocity field resulting from an intensity change on the image plane (Dubuisson and Jain 1995). Preliminary results show that motions can be extracted from a segment of bridge cable (Chang and Ji 2006). It might also be necessary to install the cameras on a mount that is also vibrating, termed “egomotion” estimation by the computer vision discipline. Armangué, *et al.* (2003) categorized egomotion estimation methods into differential and discrete methods depending on whether single or multiple cameras were used. They summarized a few algorithms that can be used to estimate the egomotion (relative camera motion).

Another class of sensor used for measuring displacement and velocity are laser Doppler vibrometers (Abe, *et al.* 2001). These sensors use laser sources to pulse light on the surface of the structure; the time it takes for the light to hit the structural surface and to reflect back provides the sensor with a distance measurement. These sensors can be purchased as either a single-point sensor or in a scanning configuration where many points on a structural surface can be scanned with one laser source. Such laser-based displacement sensors are generally classified as light detection and ranging (LIDAR) sensing.

7.2. “Fatigue” effect sensors

Fatigue is a major failure mode for metallic structural elements and should be a common monitoring issue for steel structures including bridges. Fatigue is a concept that describes the behavior of a material subject to a very large number of relatively small loading cycles, and cannot be measured directly. Instead, local changes in damage state are examined for degradation. Sensors need to detect subtle

changes in the local state before the flaws become catastrophic. Hence, measurement of the stress-time history is very important for the fatigue assessment of steel structures.

With many steel bridges or steel-concrete composite bridges in both China and the United States, there is shared interest in the fatigue problem which should be regarded as a basic issue for SHM. At present, there are few techniques for fatigue effect monitoring. The typical approach is to measure the strain-time history using strain gages. The measured strain-time history at gage locations consists of complicated cycles with variable amplitude and varying values of mean strain (de Vries 1994) where the character of recorded strain-time history is analyzed and the fatigue assessed by methods such as rain-flow counting procedures. Analytical approaches for evaluating fatigue damage and the remaining service life of steel bridges based on strain data have been proposed (Oka, *et al.* 2001).

7.3. Corrosion effect sensors

Corrosion of steel prestress tendons and rebar in concrete is one of the most frequent causes of failure of civil infrastructures. It is an extremely expensive problem in both China and the United States. Direct corrosion cost in the United States has been estimated to be more than \$276 million per year (Yunovich and Thompson 2003). Corrosion damage has also led to heavy monetary losses in China. In the past, the assessment was based primarily on qualitative visual inspections or anticipated design life (FHWA 2002). This subjective and empirical approach to corrosion management has proven insufficient. It is very important to develop “smart” corrosion effect sensors for better corrosion monitoring and prevention, which can achieve significant cost savings while providing for safer structures with longer service lives. However, “corrosion” describes a suite of chemico-physical processes that cannot be directly measured.

Numerous sensor technologies exist for monitoring corrosion effects on steel. These technologies can be categorized as electrochemical or mechanical methods. Since corrosion of rebar is an electrochemical process, such sensors measure either the electrical fields at the concrete surface or the main corrosion factors such as chloride content and pH of pore fluids. In recent years, a number of researchers have begun to explore means of integrating wireless read-out mechanisms for corrosion sensors to make their use more attractive to bridge managers. Physical approaches include fiber optic corrosion sensors, magneto-elastic corrosion sensors, and technologies using resistance probe, guided waves, ultrasonic and acoustic emission, among others. The results show promise in detecting and evaluating corrosion (Carkhuff and Cain 2003, Andringa, *et al.* 2005).

Field testing is needed for all the corrosion sensor technologies. For this purpose, a test-bed is required. It is suggested that a corroded bridge be identified to validate corrosion sensors developed within the context of a US-China collaborative program. With many structures exposed to marine environments or deicing salts in both China and the United States (specifically bridges, dams and tunnels), there is shared interest in the serious corrosion problem.

7.4. Optical fiber sensors

Infrastructures are generally large, long-span, and remain in service for a very long period of time; hence, sensors used for long-term SHM must be of high durability and have the ability to be distributed over extended areas. Practice has shown that traditional metal foil strain gage technology has problems with complex environments over long periods (temperature drifts and electrical shorts are just a couple of common problems). In recent years, fiber optic-based strain sensors, especially long-gage strain

sensors, and displacement sensors, have received much attention because of their high sensitivity and immunity to environmental factors such as electromagnetic interference.

Acknowledging the great need for durability and long period operation, some problems with fiber optic sensors should be considered: 1) need for new sensor designs; 2) combining optical fiber sensors with construction materials to develop new smart structures and system; 3) standardization of fabrication and application of optical fiber sensors; 4) low-cost modulation systems; and 5) improved signal processing for damage information.

7.5. Scour effect sensor system

Scour is the erosion of river beds in the vicinity of bridge piers, which leads to reductions in global bridge integrity and safety (Hamill 1999). Bridge scour can result in the catastrophic failure of a bridge without warning. There is currently no sensor that can sense river-bed conditions conducive to scour. With many highway bridges crossing large waterways in both the United States (530,000 national highway bridges) and China, there is shared interest in solving this serious bridge vulnerability. In the past, erosion has led to the collapse of highway bridges, such as the Schoharie Creek Bridge in New York in 1987 (Storey and Delatte, 2003). Bridges in the United States rated as scour-prone are inspected for scour during a biannual inspection (Hunt 2005). Furthermore, this specific set of 20,000 bridges are required to be inspected immediately after flood conditions occur in the vicinity of the bridge to ensure that scour has not occurred.

Numerous sensor technologies exist for monitoring bridge scour. The existing technologies are largely centered on monitoring the condition of the river bed for the presence of scour holes. Echo sounders are a common sensor used to measure scour hole depth by measuring the time required for an acoustic pulse to reflect off the streambed (Hamill 1999). Ground penetrating radar has also been used to measure scour holes near bridge piers. Ground penetrating radar, while proven effective, is very expensive (as high as \$25,000 for a system; FHWA, 2001). Other sensor technologies that exist are not used to measure for scour directly; rather, factors that contribute to scour conditions are monitored. Examples include velocity meters to measure the flow rate of the river (with high velocities increasing the likelihood of scour) and thermometers buried in the river bed (as the bed erodes, the temperature of the soil is reduced).

Initial proof-of-concept could take place in a laboratory flume tank, with flume success indicating the need for field trials. A bridge situated over a turbulent river would be an ideal candidate for a test-bed to validate scour sensors developed. Sensors developed to monitor scour could be applied to bridge piers (where applicable) or placed in the river channel itself. As such, a bridge that is readily accessible (both its piers and a shallow river bed) is desired. To record sensor measurements, a data acquisition system (wired or wireless) would be needed.

7.6. Cable force measurement

Despite the increasing popularity of cable-stayed bridges, accurate or simple methods are still needed to directly measure stresses (forces) in cable stays. The measurement of cable forces is important for monitoring excessive wind or traffic loadings, to gage the redistribution of forces present after seismic events and other natural disasters, and for detecting corrosion via loss of the cable cross section. Applications include stress measurement of strands in prestressed concrete members during or after construction, stress measurement in cable-stayed bridges, and in hanger cables and anchorage strands

for suspension bridges. Additional applications include monitoring of cable anchors for retaining walls, tunnels, and the cable supporting system of dome structures.

The current state of the art is the magnetoelastic (EM) sensor which can be designed to test all sizes of prestressed steel cables and tendons. EM is suitable for measuring quasi-static loads under any environmental condition, and the sensors can be embedded in concrete or fabricated in situ for exposed cables. The sensors are entirely suitable for sheathed cables and require no physical contact with the cable itself. Currently, the fastest sampling time is about three to ten seconds for 15.4 mm strands and 250 mm cables, respectively. Ideally, a rapid and accurate (within 5%) force measuring device is needed for measuring the stresses of strands and cables. Other advanced methods include fiber optic sensors (optical time domain reflectometry, OTDR) embedded inside the cable, vibration frequency techniques, and the direct use of load cells.

8. Sensor integration

In recent years, Motes have emerged as a viable technology that collocates sensing, computing, and wireless communication within a single node (Lynch and Loh 2006, Glaser, *et al.* 2005, Huang 2003, Hill, *et al.* 2000); this allows the sensor to make decisions and return states rather than mere numbers (see Fig. 2). With our advanced ability for computation and communication, we can assemble large arrays of interacting but autonomous sensing agents. The array itself can be thought of as a sensor. This is already being done in radio-astronomy, where arrays of telescopes distributed around the world functionally assemble into a single transducer.

We believe the future challenges in sensor development and usability revolve around the questions of integration and networking of such autonomous devices. This will require active research into many aspects of information theory (e.g. Pierce 1980), networking, system identification, and other information technologies. For usable results, these largely theoretical disciplines must be seamlessly integrated with hardware development and application-specific knowledge and insight.

However, it must be noted that wireless may not always be the solution of choice for a given set of requirements. Radio frequency (RF) communication uses greater amounts of power than other Mote components including MEMS-based sensors and modern microcontrollers (MCUs). The quality of low

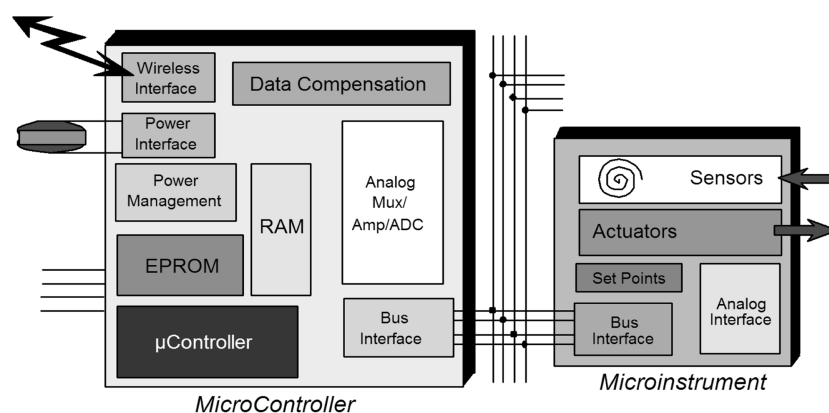

Fig. 2 Overview schematic of the self-contained Mote decision-making concept

power RF transmission is quite variable and susceptible to seemingly insignificant changes in surroundings. Such variables include orientation of antenna, distance from antenna to structural elements, proximity of water-bearing bodies, fog, etc. Data transmission rates over low power RF networks are often quite limited compared to the simplest wired bus. A single receiver can only receive one signal at a time, making true real-time operation difficult if not impossible. A solution is for each sensor node to have permanent buffer memories and to package the data to be sent into time-stamped, error-corrected packets to be transmitted in turn. This transmission can occur in pseudo real-time if the bandwidth is sufficient for rapid downloading of multiple sequential data streams. With greater data collection and computing autonomy granted to each node, accurate time synchronization in the network is now required.

The flexibility offered by Mote networks, based largely on reconfigurable software, is a double-edged sword. There is a near-infinite variety of detailed applications that can be addressed and an equally large number of possible system reactions to events. However, the flexibility of this variety is matched by the difficulty associated with low-level programming of such sensing devices. The learning curve has proved to be very steep for users interested in real applications. In addition, the software/operating systems are still in their infancy, and there is significant difficulty in developing stable and reliable applications. Perhaps one immediate solution is for software developers to write simplified toolboxes of commands commonly used for instrumentation and experimentation. In actuality, a set of commands for this purpose would be quite compact because there is great commonality among expected experimental users.

An example of integration of sensing with local computation is the use of field-programmable gate arrays (FPGAs) as a complement and/or alternative to microprocessors. The goal is to achieve greatly enhanced computational power with low energy usage and efficiency, superior flexibility of functionality, and generally optimized performance in embedded systems. FPGAs have recently evolved from limited traditional roles (e.g. glue logic) into a new alternative for offloading computationally intensive digital signal processing and beyond (e.g. ACM 2002-2005). The use of FPGAs will lead to: (1) computational efficiency, (2) power efficiency, (3) compatibility with micro-processors, and (4) powerful reconfigurable capabilities that support system-on-chips (SOCs) design concepts (e.g. Guccione, *et al.* 2002).

Current trends in computing for SHM include increases in both distribution and connectivity, leading to highly dynamic, complex environments on top of which applications must be built. To meet these goals, a "middleware" is expected to be used for reducing complicity of a SHM system. Middleware is connectivity software that joins applications through communication mechanisms creating transparency, scalability, and interoperability. It should be designed to reduce the complexities of the network, the host operating system, and any available resource servers, creating value in simplifying these tasks or the applications using it and the developers who write them. Middleware should also improve the desired characteristics of the target application and the developed system.

9. Conclusions

A working group of researchers from the United States and China has been formed to formulate a research plan to accelerate the progression of structural health monitoring technology over the next decade. The working group was assembled under the aegis of the NSF in the US and the NSFC in China. Bi-lateral funding models are proposed, but an obvious methodology is not seen. The two countries are viewed as world leaders in SHM, with the US specializing in sensor technologies and

China in the monitoring of actual structures. The group is presently made up of forty-five researchers who have an eclectic set of SHM backgrounds and practical field experience. The large size of the group underscores the quantity and quality of the SHM research being pursued in both countries. This paper summarizes the conclusions of the working group and identifies strategic technologies warranting further development and validation through a formal US-China research collaboration program.

In this paper, several overarching issues pertaining to the advancement of SHM research have been presented. Application of SHM systems to civil infrastructure systems is inherently complex and challenging due to the large size and harsh operational environments common to most civil structures. In recent years, a number of emerging technologies have shown promise in addressing both issues. For example, wireless sensors with embedded intelligence are thought to be especially useful for eradicating cable costs and permitting the SHM to be spatially distributed over larger system sizes. An immediate result of being low cost is the ability to deploy SHM systems at high nodal densities in a single structure. In addition to Motes, other novel sensing technologies are revitalizing the SHM field. MEMS-based sensors are opening up radical new monitoring possibilities by supplying small, accurate, and inexpensive transducers; in fact MEMS sensors are partly driving the rapid growth of Mote-based SHM systems. With a heavy reliance on battery power supplies, power harvesting technologies will play an increasingly important role within the SHM system. While off-the-shelf sensors have proved critical for the collection of structural response data, there is a need to develop sensors that can fulfill needs unique to SHM applications, and provide data that directly enhances damage assessment analyses. For example, novel sensor transducers are needed to enhance the ability to measure fatigue, corrosion, and bridge scour conditions, which are all failure states. The field of sensor development for SHM is a young area with wide-open possibilities.

The paper presents a state-of-the-art review of data interpretation schemes and decision making solutions. The most attractive approach to damage assessment would be through physics-based models. These models have obvious appeal to engineers since the measured parameters and model results are in a format that is closely related to the design of the structure. Difficulties for this approach include the problem of generating the proper system Green's functions. One solution might be to approach the problem from a statistical point of view. Data-driven damage detection has appeal since there are no troublesome physics to get in the way of an answer, but a data-driven result does not necessarily have a direct physical interpretation.

Sensors and their role within the global SHM system must be defined in relation to a particular project; this must be done in tandem with the design process of the structure. This approach to system deployment is in stark contrast to pursuit of generic and off-the-shelf approaches to SHM. One of the key challenges for SHM is to develop valid and useful models that clearly define for the structure owner what constitutes structural health and damage. Perhaps formulation of these state models should be part of the design phase. This opportunity is currently available with the design field placing greater emphasis on performance-based design, which utilizes models of acceptable and unacceptable performance states.

Test beds will be the stage upon which all future work will take place. Judicious use of field structures will allow isolation of key elements and allow proof-testing of all technical elements. Large-scale laboratory test-beds will allow extreme events to be simulated so that the SHM methods are ready for full-time monitoring of actual structures. In addition, these laboratory-based test-beds will allow design of systems for extreme events like earthquakes, for which years of waiting on a real structure might be needed. Once SHM technology has been validated in the laboratory, the US-China research collaboration will focus upon establishing multiple test-bed structures in the field. The role of these

test-beds are to offer US-Chinese research teams open access to jointly validate SHM technologies. Five general structural types are desired for future test-bed research: signature bridges, large key structures (steel high rise, large-span domes, nuclear power facilities), offshore platforms, pre-cast girder bridges, lifeline systems, and the built environment. Generation of SHM data from test-beds will allow engineers to begin to examine collected data to determine if it is supplying the pertinent data needed to support damage models that serve as the basis of the damage assessment process. In addition, the long-term reliability of the SHM can be quantitatively analyzed, with sensor drifts and sensor failure identified and accounted for. Sensor confidence issues must be addressed prior to commercial adoption of SHM systems.

References

- Abe, M., Fujino, Y. and Kaito, K. (2001), "Damage detection of civil concrete structures by laser doppler vibrometry", *Proceedings of the International Modal Analysis Conference*, **1**, 704-709.
- Analog Devices, http://www.analog.com/analog_root/static/mems/images/202DIE.jpg.
- Andringa, M. M., Neikirk, D. P., Dickerson, N. P. and Wood, S. L. (2005), "Unpowered wireless corrosion sensor for steel reinforced concrete", *2005 IEEE Sensors*, Irvine.
- Arici, Y. and Mosalam, K. M. (2005), "Modal identification of bridge systems using state-space methods", *Structural Control and Health Monitoring*, **12**(3-4), 381-404.
- Armangué, X., Araújo, H. and Salvi, J. (2003), "A review on egomotion by means of differential epipolar geometry applied to the movement of a mobile robot", *Pattern Recognition*, **36**(12), 2927-2944.
- Baise, L. G., Glaser, S. D. and Sugano, T. (2001), "Consistency of dynamic site response at Port Island", *Earthq. Eng. Struct. Dyn.*, **30**(6), 803-818.
- Baise, L. G. and Glaser, S. D. (2000), "Consistency of site response estimates made using system identification," *Bulletin, Seismological Society of America*, **90**(4), 993-1009.
- Beck, J. L. and Katafygiotis, L. S. (1998), "Updating models and their uncertainties: Bayesian statistical framework", *J. Eng. Mech.*, **124**(4), 455-461.
- Bishop, C. M. (1995), *Neural Networks for Pattern Recognition*, Oxford University Press, Oxford, UK.
- Bucher, C., Huth, O. and Macke, M. (2003), "Accuracy of system identification in the presence of random fields", *Proceedings of the 9th International Conference on the Applications of Statistics and Probability (ICASP 9)*.
- Cantrell, J. H. (2004), "Substructural organization, dislocation plasticity and harmonic generation in cyclically stressed wavy slip metals", *Proc. R. Soc. Lond.*, **A 460**, 757.
- Cantrell, J. H. and Yost, W. T. (1994), "Acoustic harmonic-generation from fatigue-induced dislocation dipoles", *Philosophical Magazine A-Physics of Condensed Matter Structure Defects and Mechanical Properties*, **69**, 315.
- Carkhuff, B. and Cain, R. (2003), "Corrosion sensors for concrete bridges", *IEEE Instrumentation and Measurement Magazine*, **6**(2), 19-24.
- Carlstrom, P. (2005), "As solar gets smaller, its future gets brighter", *San Francisco Chronicle*, July 11, 2005.
- Castillo, E. (1988), *Extreme Value Theory in Engineering*, Academic Press, San Diego.
- Chan, T. H., Ni, Y. Q. and Ko, J. M. (1999), "Neural network novelty filtering for anomaly detection of Tsing Ma bridge cables", *Structural Health Monitoring 2000*, Stanford University, Palo Alto, California, 430-439.
- Chang, C. C. and Ji, Y. F. (2006a), "A flexible videogrammetric technique for three-dimensional structural vibration measurement", *J. Eng. Mech., ASCE*, In press.
- Chiang, D. Y. and Lai, W. Y. (1999), "Structural damage detection using the simulated evolution method", *AIAA Journal*, **37**(10), 1331-1333.
- Ching, J. and Glaser, S. D. (2003a), "Tracking rapidly changing dynamical systems using a semi-parametric statistical method based on wavelets", *Earthq. Eng. Struct. Dyn.*, **32**, 2377-2406.
- Ching, J. and Glaser, S. D. (2003b), "Identification of soil degradation during earthquake excitations by Bayesian inference", *Earthq. Eng. Struct. Dyn.*, **32**, 845-869.

- Chung, H.-C., Enomoto, T., Shinozuka, M., Chou, P., Park, C., Yokoi, I. and Morishita, S. (2004), "Real time visualization of structural response with wireless MEMS sensors", *Proceedings of 13th World Conference on Earthquake Engineering*, August 2-6, Vancouver, BC, Canada.
- Ciloglu, K., Catbas, F. N., Pervizpour, M., Wang, S. and Aktan, A. (2001), "Structural identification of phenomenological physical models with controlled mechanisms of uncertainty", *6th Annual SPIE Int'l Symposium on NDE for Health Monitoring and Diagnostics*, 4-8 March, Newport Beach, CA USA.
- Demetriou, M. and Hou, Z. (1999), "A comparison study of on-line fault diagnosis schemes", *Proc., 13th Conf. on Engrg. Mech.*, ASCE, Reston, Va. (CD-ROM).
- Dosch, J. J., Inman, D. J. and Garcia, E. (1992), "A self-sensing piezoelectric actuator for collocated control", *J. Intell. Mats. Sys. & Struct.*, **3**, 166-185.
- Dubuisson, M. P. and Jain, A. K. (1995), "Contour extraction of moving objects in complex outdoor scenes", *Int. J. Computer Vision*, **14**(1), 83-105.
- DustNetworks (2006), www.dustnetworks.com.
- Egusa, S. and Iwasawa N. (1998), "Piezoelectric paints as one approach to smart structural materials with health-monitoring capabilities", *Smart Mater. Struct.*, **7**(4), 438-445.
- Farrar, C. R., Baker, W. E., Bell, T. M., Cone, K. M., Darling, T. W., Duffey, T. A., Eklund, A. and Migliori, A. (2004), "Dynamic characterization and damage detection in the I-40 Bridge over the Rio Grande", *Los Alamos National Laboratory Technical Report LA-12767-MS*.
- FHWA (Federal Highway Administration), (2002), "FHWA bridge inspector's reference manual", *Technical Report FHWA-NHI 03-001*.
- Fortner, B. (2003), "Embedded miniature sensors detect chloride in bridge decks", *Civil Engineering, ASCE*, June, 42-43.
- Fraden, J. (1993), *AIP Handbook of Modern Sensors: Physics, Designs, and Applications*, American Institute of Physics, New York.
- Friswell, M. and Mottershead, J. (1995), *Finite Element Model Updating in Structural Dynamics*. Dordrecht, The Netherlands, Kluwer.
- Fritzen, C. P. and Bohle, K. (1999), "Identification of damage in large scale structures by means of measured FRFs - procedure and application to the I40-highway bridge", *Proceedings of the International Conference on Damage Assessment of Structures (DAMAS 99)*, Dublin, Ireland, 310-319.
- Fu, X. and Chung, D. D. (1996), "Self-monitoring concrete", *Proceedings of SPIE*, **2719**, 62-68.
- Gao, H., Shi, Y. and Rose, J. L. (2005), "Guided wave tomography on an aircraft wing with leave in place sensors", *AIP Conference Proceedings*, **760**, 7887-94.
- Garcia, G. and Stubbs, N. (1997), "Application and evaluation of classification algorithms to a finite element model of a three-dimensional truss structure for nondestructive damage detection", *Smart Systems for Bridges, Structures, and Highways, Proceedings of SPIE*, **3043**, 205-216.
- Gelman, A. (1998), "A Bayesian formulation of exploratory data analysis and goodness-of-fit testing", *Int. Statistical Review*, **71**, 369-382.
- Giurgiutiu, V., Zagrai, A. and Bao, J. (2004), "Damage identification in aging aircraft structures with piezoelectric wafer active sensors", *J. Intelligent Mater. Sys. Struct.*, **15**(9-10), 673-687.
- Glaser, S. D., Shoureshi, R. and Pescovitz, D. (2005), "Future sensing systems", *Smart Struct. Sys.*, **1**(1), 103-120.
- Grosse, C. U., Glaser, S. D. and Krüger, M. (2006), "Wireless acoustic emission sensor networks for structural health monitoring in civil engineering", *Proceedings, European Conference on Non-Destructive Testing*, Berlin, 6, Tu.1.7.3.
- Gu, H., Song, G., Dhonde, H., Mo, Y. L. and Yan, S. (2006a), "A unified piezo-based approach for strength and health monitoring of concrete structures", *The Proceeding of 4th China-Japan-US Symposium on Structural Control and Monitoring* (Hangzhou, China), Oct. 16-17.
- Guccione, S., Verkest, D. and Bolsens, I. (2002), "Design technology for networked reconfigurable FPGA platforms", *Proceedings of the conference on Design, automation and test in Europe*, 994-1002.
- Hamill, L. (1990), *Bridge Hydraulics*, E. & F.N. Spon, London, UK.
- Hart, G. C. and Yao, J. T. P. (1977), "System identification in structural dynamics", *J. Eng. Mech. Div., ASCE*, **103**(EM6), 1089-104.
- Hill, J., Szweczyk, R., Woo, A., Hollar, S., Culler, D. and Pister, K. J. S. (2000), "System architecture directions

- for networked sensors”, *Proceedings of Ninth International Conference on Architectural Support for Programming Languages and Operating Systems*, 93-104.
- Huang, G. (2003), “Casting the Wireless Sensor Net”, *MIT Technology Review*, July, 12, 2003. <http://www.technologyreview.com/InfoTech/13235/>.
- Hunt, B. E. (2005), “Scour monitoring programs for bridge health”, *Proceedings of the Transportation Research Board - 6th International Bridge Engineering Conference: Reliability, Security, and Sustainability in Bridge Engineering*, 531-536.
- Inada, T., Shimamura, Y., Todoroki, A., Kobayashi, H. and Nakamura, H. (1999), “Damage identification method for smart composite cantilever beams with piezoelectric materials”, *Structural Health Monitoring 2000*, Stanford University, Palo Alto, California, 986-994.
- Ihn, J.-B. and Chang, F.-K. (2004), “Detection and monitoring of hidden fatigue crack growth using a built-in piezoelectric sensor/actuator network: I. diagnostics”, *Smart Materials and Structures*, **13**(3), 609-20.
- Judy, J. W. (2001), “Microelectromechanical systems (MEMS): fabrication, design and applications”, *Smart Mater. Struct.*, **10**(6), 1115-1134.
- Kessler, S. S. and Spearing, S. M. (2002), “In-situ sensor-based damage detection of composite materials for structural health monitoring”, *Collection of Technical Papers - AIAA/ASME/ASCE/AHS/ASC Structures, Structural Dynamics and Materials Conference*, **4**, 2706-2716.
- Koh, B. H., Li, Z., Dharap, P., Nagarajaiah, S. and Phan, M. Q. (2005a), “Actuator failure detection through interaction matrix formulation”, *J. Guidance, Control, and Dynamics*, **28**(5), 895-901.
- Koh, B. H., Dharap, P., Nagarajaiah, S. and Phan, M. Q. (2005b), “Real-time structural Damage monitoring by input error eunction”, *J. American Inst. Aeronautics and Astronautics*, **43**(8), 1808-1814.
- Lapin, L. L. (1990), *Probability and Statistics for Modern Engineering*, PWS-Kent, Boston
- Kovacs, G. T. A. (1998), *Micromachined Transducers Sourcebook*, McGraw-Hill.
- Li, H., Xiao, H. and Ou, J. (2004), “A study on mechanical and pressure-sensitive properties of cement mortar with nanophase materials”, *Cement Concrete Res.*, **34**(3), 435-438.
- Li, H., Xiao, H. and Ou, J. (2006), “Effect of compressive strain on electrical resistivity of carbon black-filled cement-based composites”, *Cement Concrete Comp.*, **28**, 824-828.
- Li, S. L. and Li, H. (2006), “Model updating for uncertain structures with interval parameters”, *The Proceeding of First Pacific-Asian Workshop on Structural Health Monitoring*.
- Lin, X. and Yuan, F. G. (2001), “Diagnostic lamb waves in an integrated piezoelectric sensor/actuator plate: analytical and experimental studies”, *Smart Mater. Struct.*, **10**, 907-913.
- Liu, S. C. and Yao, J. T. P. (1978), “Structural identification concept”, *J. Struct. Div.*, 104(ST12), 1845-858.
- Loh, K. J., Lynch, J. P. and Kotov, N. (2006), “Nanoengineered inductively coupled carbon nanotubes wireless strain sensors”, *Proceedings of the 4th World Conference on Structural Control and Monitoring*, (4WCSCM), San Diego, CA, 2006.
- Loh, C. H. and Huang, C. C. (1999), “Damage identification of multi-story steel frames using neural networks”, *Structural Health Monitoring 2000*, Stanford University, Palo Alto, California, 390-399.
- Lynch, J. P. (2004), “Design of a wireless active sensing unit for localized structural health monitoring”, *J. Struct. Control Health Monitoring*, **12**(3-4), 405-423.
- Lynch, J. P. (2005), “Damage characterization of the IASC-ASCE structural health monitoring benchmark structure by transfer function pole migration”, *Proceedings of the 2005 ASCE Structures Congress*, New York, NY.
- Lynch, J. P. and Hou, T.-C. (2005), “Conductivity-based strain and damage monitoring of cementitious structural components”, *SPIE 12th Annual International Symposium on Smart Structures and Materials*, San Diego, CA, March 6-10, 2005.
- Lynch, J. P. and Loh, K. J. (2006), “A summary review of wireless sensors and sensor networks for structural health monitoring”, *Shock Vib.*, **38**(2), 91-128.
- Masri, S. F., Smyth, A. W., Chassiakos, A. G., Caughey, T. K. and Hunter, N. F. (2000), “Application of neural networks for detection of changes in nonlinear systems”, *J. Eng. Mech.*, (6), 666-676.
- Masuda, A., Nakaoka, A., Sone, A. and Yamamoto, S. (1995), “Health monitoring system of structures based on orthonormal wavelet transform”, *Seismic Engng.*, **312**, 161-167.
- Menzies, T. and Hu, Y. (2003), “Data mining for very busy people”, *IEEE Computer Magazine*, **36**(11), 18-25.

- Moon, F. L. and Aktan, A. E. (2006), "Impacts of epistemic (bias) uncertainty on structural identification of constructed (civil) systems", *Shock Vib. Digest*, **38**, 399-420.
- Moslem, K. and Nafaspour, R. (2002), "Structural damage detection by genetic algorithms", *AIAA J.*, **40**(7), 1395-1401.
- Nakamura, M., Masri, S. F., Chassiakos, A. G. and Caughey, T. K. (1998), "A method for non-parametric damage detection through the use of neural networks", *Earthq. Eng. Struct. Dyn.*, **27**, 997-1,010.
- Masri, S. F., Smyth, A. W., Chassiakos, A. G., Caughey, T. K. and Hunter, N. F. (2000), "Application of neural networks for detection of changes in nonlinear systems", *J. Eng. Mech.*, (6), 666-676.
- Ostachowicz, W., Krawczuk, M. and Cartmell, M. (2002), "The location of a concentrated mass on rectangular plates from measurements of natural vibrations", *Comput. Struct.*, **80**, 1419-1428.
- Ou, J. P., Li, H. W., Xiao, Y. Q. M. and Li, Q. S. (2005), "Health dynamic measurement of tall building using wireless sensor network", *SPIE Vol. 5765*, 205-216.
- Oka, V. G., Hopwood, T. and Harik, I. E. (1989), "Fatigue analysis of steel bridges using a portable microcomputer based strain gage system", *Comput. Struct.*, **31**(2), 151-86.
- Park, S., Yun, C.-B., Roh, Y. and Inman, D. J., (2006), "Active sensing network system for crack detection on welded zone of steel truss member", *Proceedings of SPIE*, 6174.
- Park, G., Cundy, A. L., Sohn, H. and Farrar, C. R. (2005), "An outlier analysis framework for impedance-based structural health monitoring", *J. Sound Vib.*, **286**(1), 229-250.
- Park, H. W. and Sohn, H. (2006), "Parameter estimation of the generalized extreme value distribution for structural health monitoring", *J. Probabilistic Eng. Mech.*, **21**(4), 366-376.
- Park, Z. T., Choi, Y. S., Kima, J. G. and Chung, L. (2005), "Development of a galvanic sensor system for detecting the corrosion damage of the steel embedded in concrete structure: Part 2, laboratory electrochemical testing of sensors in concrete", *Cement Concrete Res*, **35**(6), 1814-1819.
- Pickard, W. F., Knoblauch, M., Peters, W. S. and Shen, A. (2006), "Prospective energy densities in the forisome, a new smart material", *Materials Science and Engineering*, **26**(1), 104-112.
- Pierce, J. R. (1980), *An Introduction to Information Theory*, Dover, New York.
- Pister, K. (2006), *Personal communication*.
- Popovics, J. S. and Rose, J. L. (1994), "A survey of developments in ultrasonic NDE of concrete", *IEEE Transactions on Ultrasonics, Ferroelectrics and Frequency Control*, **41**, 140-143.
- Poulin, G., Sarraute, E. and Costa, F. (2004), "Generation of electrical energy for portable devices comparative study of an electromagnetic and a piezoelectric system", *Sensors and Actuators A*, **116**, 461-471.
- Rizzoni, G. and Min P. S. (1991), "Detection of sensor failures in automotive engines", *IEEE Trans. Vehicular Tech.*, **40**(2), 487-500.
- Roundy, S. and Wright, P. K. (2004), "A piezoelectric vibration based generator for wireless electronics", *Smart Mater. Struct.*, **13**, 1131-1142.
- Ruotolo, R. and Surace, C. (1997), "Damage assessment of multi-cracked beams using combinatorial optimisation", *Structural Damage Assessment Using Advanced Signal Processing Procedures*, Proceedings of DAMAS '97, University of Sheffield, UK, 77-86.
- Rytter, A. and Kirkegaard, P. (1997), "Vibration based inspection using neural networks", *Structural Damage Assessment Using Advanced Signal Processing Procedures*, Proceedings of DAMAS '97, University of Sheffield, UK, 97-108.
- Senturia, S. (2001), *Microsystem Design*. Kluwer Academic Publishers, Boston.
- Schultz, M. (2006), *Nanoengineering of Structural, Functional, and Smart Materials*, CRC Press, 169-198.
- Simmers, G. E., Sodano, H. A., Park, G. and Inman, D. J. (2006), "Detection of corrosion using piezoelectric impedance-based structural health monitoring", *AIAA J.*, **44**(11), 2800-2803
- Simoff, S. J. and Maher M. L. (1998), "Ontology-based multimedia data mining for design information retrieval", *Proceedings of ACSE Computing Congress*, 212-223, <http://www.people.arch.usyd.edu.au/~mary/Pubs/pdf/asce98.pdf>.
- Smart Materials (2006), <http://www.smart-material.com/>.
- Sodano, H. A., Inman, D. J. and Park, G. (2004), "A review of power harvesting from vibration using piezoelectric materials", *Shock Vib. Digest*, **36**(3), 197-205.
- Sohn, H. and Law, K. L. (1997), "A Bayesian probabilistic approach for structure damage detection", *Earthq. Eng.*

- Struct. Dyn.*, **26**(12), 1259-1281.
- Sohn, H., Czarnecki, J. J. and Farrar, C. R. (2000), "Structural health monitoring using statistical process control", *J. Struct. Eng.*, **126**(11), 1356-1363.
- Sohn, H., Farrar, C. R., Hunter, N. S. and Worden, K. (2001), "Structural health monitoring using statistical pattern recognition techniques", *ASME Journal of Dynamic Systems, Measurement and Control*, **123**(4), 706-711.
- Sone, A., Yamamoto, S., Masuda, A., Nakaoka, A. and Ashino, R. (1995), "Estimation of cumulative damage of a building with hysteretic restoring force by using wavelet analysis of strong motion records", *Japan Struct. Constr. Eng.*, **476**, 67-74.
- Song, G., Gu, H., Mo, Y. L., Hsu, T. T. C., Dhonde, H. and Zhu, R. H. (2004), "Health monitoring of a reinforced concrete bridge bent-cap using piezoceramic materials", *Proceedings of the Third European Conference on Structural Control (3ECSC)* (Vienna, Austria), July.
- Song, G., Gu, H., Mo, Y. L., Hsu, T. T. C., Dhonde, H. and Zhu, R. H. (2005), "Health monitoring of a concrete structure using piezoceramic materials", *Proceedings of 2005 SPIE International Symposium on Smart Structures and Materials*, **5765**, 5765-5713.
- Song, G., Olmi, C. and Gu, H. (2005), "An overheight collision detection and evaluation system for bridge girder using piezoelectric transducer", *Proceedings of 2nd International Conference on Structural Health Monitoring of Intelligent Infrastructure* (Shenzhen, China).
- Staszewski, W. J., Lee, B. C., Mallet, L. and Scarpa, F. (2004), "Structure health monitoring using scanning laser vibrometry: I. Lamb wave sensing", *Smart Mater. Struct.*, **13**(2), 251-260.
- De Stefano, A., Sabia, D. and Sabia, L. (1997), "Structural identification using ARMAV models from noisy dynamic response under unknown random excitation", *Structural Damage Assessment Using Advanced Signal Processing Procedures, Proceedings of DAMAS '97*, University of Sheffield, UK, 419-428.
- Storey, C. and Delatte, N. (2003), "Lessons from the collapse of the schoharie creek bridge", *Proceedings of the Third Congress Forensic Engineering*, San Diego, CA, 158-167.
- Sun, Z. and Chang, C. C. (2004), "Statistical wavelet-based method for structural health monitoring", *J. Struct. Eng.*, **130**(7), 1055-1062.
- Talesnick, M. (2006), "Determination of shear interface parameters between rock blocks for centrifuge modeling", *Rock Mech. Rock Eng.*, (in press).
- de Vries, M., Nasta, M., Bhatia, V., Tran, T., Greene, J., Claus, R. O. and Masri, S. (1995), "Performance of embedded short-gage-length optical fiber sensors in a fatigue-loaded reinforced concrete specimen", *Smart Mater. Struct.*, **4**(1A), A107-A113.
- Worden, K. and Lane, A. J. (2001), "Damage identification using support vector machines", *Smart Mater. Struct.*, **10**, 540-547.
- Wu, F. and Chang, F. K. (2001), "A built-in active sensing diagnostic system for civil infrastructure systems", *Proceedings of SPIE*, **4330**, 27-35.
- Yan, A. M., Kerschen, G., Boe, P. and Golinval, J. C. (2005), "Structural damage diagnosis under varying environmental conditions – Part I: a linear analysis", *Mechanical Systems and Signal Processing*, **19**, 847-864.
- Yanev, B. (2003), "Structural health monitoring as a bridge management tool", *Structural Health Monitoring and Intelligent Infrastructure*, Wu ZS, Abe M, editors, Balkema, 87-95.
- Yang, J. N., Lei, Y., Pan, S. and Huang, N. (2003a), "Identification of linear structures based on Hilbert-Huang transform. Part 1: Normal modes", *Earthq. Eng. Struct. Dyn.*, **32**(9), 1443-1467.
- Yang, J. N., Lei, Y., Pan, S. and Huang, N. (2003b), "Identification of linear structures based on Hilbert-Huang transform. Part 2: Complex modes", *Earthq. Eng. Struct. Dyn.*, **32**(10), 1533-1554.
- Yang, J. N., Lei, Y., Lin, S. and Huang, N. (2004), "Hilbert-Huang based approach for structural damage detection", *J. Eng. Mech.*, **130**(1), 85-95.
- Yunovich, M. and Thompson, N. G. (2003), "Corrosion of highway bridges: economic impact and control methodologies", *Concrete Inter.*, **25**(1), 52-57.
- Zhang, Y. (2006), "In-situ fatigue crack detection using piezoelectric paint sensor", *J. Intelligent Material Sys. Struct.*, **17**(10), 843-852.