

Sensors and Asymptotic ω -observer for Distributed Diffusion Systems

R. Al-Saphory* and A. El Jai

University of Perpignan, Systems Theory Laboratory, 52, Avenue de Villeneuve, 66860 Perpignan, France.

* Author to whom correspondence should be addressed. E-mail: saphory@univ-perp.fr

Received: 18 July 2001 / Accepted: 16 August 2001 / Published: 27 October 2001

Abstract: The aim of this paper is to study the regional observer concept through the consideration of sensors. For a class of distributed diffusion systems, we propose an approach derived from the Luenberger observer type as introduced by Gressang and Lamont [1]. Furthermore, we show that the structures of sensors allow the existence of regional observer and we give a sufficient condition for each regional observer. We also show that, there exists a dynamical system for diffusion systems is not observer in the usual sense, but it may be regional observer.

Keywords: Sensors, ω -observer, Distributed diffusion systems

Introduction

The observability problems in distributed systems have been the subject of a good deal of research [2-7]. These systems are the general representation of several physical systems described by partial differential equations or differential equations [8-9]. In this paper, we are concerned with some methods of construction of an asymptotic regional state for infinite dimensional systems described, in terms of linear semi-group. The notion of asymptotic regional construction has been introduced by Al-Saphory and El Jai [10] and is based on the concept of regional detectability [11]. In this work, we develop this approach and the mathematical tools which allow to construct various types of ω -observers in a given subregion ω of the domain Ω , in connection with sensors structures. The results are considered in a particular case of parabolic systems. The principal reason behind introducing this

concept is that it provides a means to deal with some physical problems concern the determination of laminar flux conditions, developed in steady state by vertical uniformly heated plate (Fig. 1).

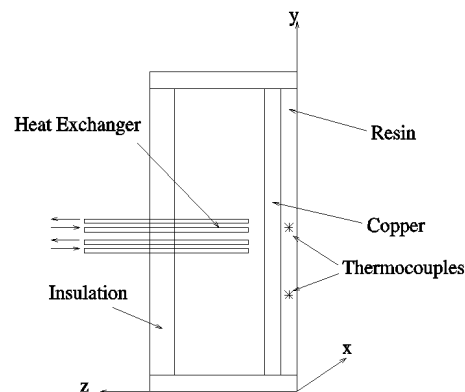

Figure 1. Profile of the active plate.

This approach can be extended to find the unknown boundary convective condition on the front face of the active plate, as in [9]. The reconstruction is based on knowledge of the dynamical system (ω -observer) and the measurement given by internal pointwise sensors (that means by the thermocouples).

The paper is organized as follows. Section 2 is devoted to the presentation of the system under consideration and preliminaries. We recall that the definitions of ω -stability and ω -detectability and we also give the definitions of different types of ω -observers (case general, identity and reduced-order). Section 3, we characterize each ω -observers in terms of sensors structures and we give a counter-example of the case ω -observer is not observer in the whole domain Ω . The useful applications of these results are considered.

2. Asymptotic ω -observer

2.1 Description systems and preliminaries

Suppose $(S_A(t))_{t \geq 0}$ an exponentially stable, strongly semi-group of operators on the space X , with generator $A : D(A) \rightarrow X$ may be linear differential elliptic defined by

$$Ax(\xi, t) = \Delta x(\xi, t)$$

We denote $Q = \Omega \times (0, \infty)$, $\Theta = \partial\Omega \times (0, \infty)$ and we consider

$$\begin{cases} \frac{\partial x}{\partial t}(\xi, t) = \Delta x(\xi, t) + Bu(t) & Q \\ x(\eta, t) = 0 & \Theta \\ x(\xi, 0) = x_0(\xi) & \Omega \end{cases} \quad (2.1)$$

and measurements are given by the output function

$$z(t) = Cx(\xi, t) \quad (2.2)$$

where the following hypothesis are considered.

- The operators Δ is self-adjoint with compact resolvent.
- Ω is an open regular bounded set of \mathcal{R}^n ($n=1, 2, 3$) with smooth boundary $\partial\Omega$.
- ω is a nonempty given subregion of Ω .
- X, U, \mathcal{O} are separable Hilbert spaces where X is the state space, U the control space and \mathcal{O} the observation space and with $X = L^2(\Omega)$, $U = L^2(0, \infty; \mathcal{R}^q)$ and $\mathcal{O} = L^2(0, \infty; \mathcal{R}^p)$.
- The operators $B : U \rightarrow X$ and $C : X \rightarrow \mathcal{O}$ are bounded linear and depend on the structure of actuators and sensors [7]. Under the above assumption, the system (2.1) has a unique solution given by

$$x(\xi, t) = S_A(t)x_0(\xi) + \int_0^t S_A(t-s)Bu(s)ds. \quad (2.3)$$

The problem consists to construct a regional observer which gives an estimated state of $x(\xi, t)$ in ω by using only the measurements (2.2). We recall that:

- A sensor may be defined by any couple (D, g) where :
 1. D denotes a closed subset of $\bar{\Omega}$, which is spatial support of sensors,
 2. $g \in L^2(D)$ defines the spatial distribution of measurements on D .

According to the choice of the parameters D and g , we have various types of sensors. A sensors may be of zone types when $D \subset \Omega$. The output function (2.2) can be written in the form

$$z(t) = Cx(\xi, t) = \langle x(\cdot, t), g(\cdot) \rangle_{L^2(D)} \quad (2.4)$$

A sensor may also be a pointwise when $D = \{b\}$ and $g = \delta(\cdot - b)$ where δ is the Dirac mass concentrated in b . Then the output function (2.2) may be given by the form

$$z(t) = Cx(\xi, t) = x(b, t). \quad (2.5)$$

In the case of boundary zone sensor, we consider $D = \Gamma$ with $\Gamma \subset \partial\Omega$ and $g \in L^2(\Gamma)$. The output function (2.2) can then be written in the form

$$z(t) = Cx(\xi, t) = \langle x(\cdot, t), g(\cdot) \rangle_{L^2(\Gamma)}. \quad (2.6)$$

The operator C is unbounded and some precautions must be taken in [7].

- The function χ_ω is defined by

$$\begin{aligned} \chi_\omega : L^2(\Omega) &\longrightarrow L^2(\omega) \\ x &\longrightarrow \chi_\omega x = x|_\omega \end{aligned} \quad (2.7)$$

where $x|_\omega(\xi, t)$ is the restriction of the state $x(\xi, t)$ to ω . Define now the operator

$$K : x \in X \rightarrow Kx = CS_A(t)x \in \mathcal{O} \quad (2.8)$$

then $z(t)=K(t)x_0(\cdot)$. We denote by $K^* : \mathcal{O} \rightarrow X$ the adjoint of K given by

$$K^* z^*(\cdot, t) = \int_0^t S^*(s) C^* z^*(\cdot, s) ds. \quad (2.9)$$

- The autonomous system associated to (2.1)-(2.2) is exactly (respectively weakly) ω -observable if :

$$\text{Im} \chi_\omega K^* = L^2(\omega) \quad (\text{respectively} \quad \overline{\text{Im} \chi_\omega K^*} = L^2(\omega)).$$

- The suit of sensors $(D_i, g_i)_{1 \leq i \leq q}$ is ω -strategic if the system (2.1)-(2.2) is weakly ω -observable [12]. The concept of ω -strategic has been extended to the regional boundary case as in [13-15].

2.2 ω -observer

The theory of observer was introduced by Luenberger [16] and has been generalized to systems described by semi-group operators [1]. Recently, these results have been extended to the regional case by Al-Saphory and El Jai [11]. This extension is based on the concept of regional detectability. In this section, we define the asymptotic ω -observer in a given subregion ω .

Definition 2.1. The system (2.1) is said to be ω -stable, if the operator A generates a semi-group which is stable on $L^2(\omega)$. It is easy to see that the system (2.1) ω -stable, if and only if, for some positive constants M and α , we have

$$\| \chi_\omega S_A(t) \|_{L^2(\omega)} \leq M e^{-\alpha t}, \quad \forall t \geq 0$$

If $(S_A(t))_{t \geq 0}$ is stable semi-group on $L^2(\omega)$, then for all $x_0 \in L^2(\Omega)$, the solution of the associated autonomous system satisfies

$$\lim_{t \rightarrow \infty} \| x \|_{L^2(\omega)} = \lim_{t \rightarrow \infty} \| \chi_\omega S_A(t) x_0 \|_{L^2(\omega)} = 0 \quad (2.10)$$

Definition 2.2. The system (2.1) together with the output function (2.2) is said to be ω -detectable if there exists an operator $H_\omega : \mathcal{O} \rightarrow L^2(\omega)$ such that $(A - H_\omega C)$ generates a strongly continuous semi-group $(S_{H_\omega}(t))_{t \geq 0}$ which is stable on $L^2(\omega)$.

Definition 2.3. Suppose that there exists a dynamical system with state $y(\xi, t) \in Y$ (a Hilbert space) given by

$$\begin{cases} \frac{\partial y}{\partial t}(\xi, t) = F_\omega y(\xi, t) + G_\omega u(t) + H_\omega C x(\xi, t) & \mathcal{Q} \\ y(\eta, t) = 0 & \Theta \\ y(\xi, 0) = y_0(\xi) & \Omega \end{cases} \quad (2.11)$$

where F_ω generates a strongly continuous semi-group $(S_{F_\omega}(t))_{t \geq 0}$ which is stable on the Hilbert space Y , $G_\omega \in \mathcal{L}(U, Y)$ and $H_\omega \in \mathcal{L}(\mathcal{O}, Y)$. The system (2.11) defines an ω -estimator for $\chi_\omega T x(\xi, t)$ if:

1. $\lim_{t \rightarrow \infty} [y(\xi, t) - \chi_\omega T x(\xi, t)] = 0, \xi \in \omega$
2. $\chi_\omega T x$ maps $D(\Delta)$ into $D(F_\omega)$ where $x(\xi, t)$ and $y(\xi, t)$ are the solutions of (2.1) and (2.11).

Definition 2.4. The system (2.11) is ω -observer for the system (2.1)-(2.2) if it satisfies the following conditions:

1. There exists $R \in \mathcal{L}(\mathcal{O}, L^2(\omega))$ and $S \in \mathcal{L}(L^2(\omega))$ such that $RC + S\chi_\omega T = I_\omega$
2. $\chi_\omega T \Delta - F_\omega \chi_\omega T = H_\omega C$ and $G_\omega = \chi_\omega T B$.
3. The system (2.11) determines ω -estimator for $\chi_\omega T x(\xi, t)$.

The purpose of ω -observer is to provide an approximation to the state of the original system. This approximation is given by

$$\hat{x}(\xi, t) = Rz(t) + Sy(\xi, t)$$

It is clear that:

- The system (2.11) is said to be an identity ω -observer for the system (2.1)-(2.2) if $\chi_\omega T = I_\omega$ and $X = Y$.
- The system (2.11) is said to be a reduced-order ω -observer for the system (2.1)-(2.2) if $X = \mathcal{O} \oplus Y$.

3. Sensors and ω -observer reconstruction

In this section, we give an approach which allows to construct an ω -estimator of $Tx(\xi, t)$. This method avoids the calculation of the inverse operators [14] and the consideration of the initial state [12], it enables to observe the current state in ω without needing the effect of the initial state of the original system. Let us consider the set (φ_{nj}) of eigenfunctions of $L^2(\Omega)$ orthonormal in $L^2(\omega)$ associated with the eigenvalues λ_n of multiplicity r_n and suppose that the system (2.1) has unstable modes.

3.1 General case

The problem of asymptotic ω -observability may be studied through the observation operator C . That means, we can characterize the ω -observer by a good choice of the sensors. For that objective, suppose that information is retrieved from the system by p sensors $(D_b, g_i)_{1 \leq i \leq p}$. In the asymptotic regional state reconstruction various types of sensors can be considered (Fig. 2).

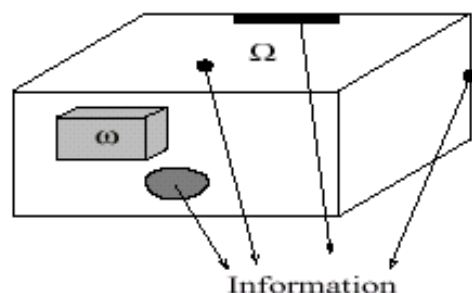

Figure 2. The estimated state in ω and various sensor locations.

3.1.1 Case of pointwise sensors

Consider again the system

$$\begin{cases} \frac{\partial x}{\partial t}(\xi, t) = \Delta x(\xi, t) + Bu(t) & \mathcal{Q} \\ x(\eta, t) = 0 & \Theta \\ x(\xi, 0) = x_0(\xi) & \Omega \end{cases} \quad (3.1)$$

In this case the output function (2.2) is given by

$$z(t) = Cx(., t) = x(b_i, t) \quad (3.2)$$

where $b_i \in \Omega$ is the sensor locations. Let ω be a given subdomain of Ω and assume that for $T \in \mathcal{L}(L^2(\Omega))$, and $\chi_\omega T$ there exists a system with state $y(\xi, t)$ such that

$$y(\xi, t) = \chi_\omega T x(\xi, t). \quad (3.3)$$

where χ_ω is defined in (2.7) and we denote $T_\omega = \chi_\omega T$. The equations (3.2)-(3.3) give

$$\begin{bmatrix} z \\ y \end{bmatrix} = \begin{bmatrix} C \\ T_\omega \end{bmatrix} x. \quad (3.4)$$

If we assume that there exist two linear bounded operators R and S where $R : \mathcal{O} \rightarrow L^2(\omega)$ and $S : L^2(\omega) \rightarrow L^2(\omega)$, such that $RC + ST_\omega = I$, then by deriving $y(\xi, t)$ in (3.3) we have

$$\begin{aligned} \frac{\partial y}{\partial t}(\xi, t) &= T_\omega \frac{\partial x}{\partial t}(\xi, t) = T_\omega \Delta x(\xi, t) + T_\omega Bu(t) \\ &= T_\omega ASy(\xi, t) + T_\omega \Delta Rx(b_i, t) + T_\omega Bu(t). \end{aligned}$$

Consider now the system (which is destined to be the ω -observer)

$$\begin{cases} \frac{\partial \hat{y}}{\partial t}(\xi, t) = F_\omega \hat{y}(\xi, t) + G_\omega u(\xi, t) + H_\omega x(b_i, t) & \mathcal{Q} \\ \hat{y}(\eta, t) = 0 & \Theta \\ \hat{y}(\xi, 0) = \hat{y}_0(\xi) & \Omega \end{cases} \quad (3.5)$$

where F_ω generates a strongly continuous semi-group $(S_{F_\omega}(t))_{t \geq 0}$ which is assumed to be stable on $L^2(\omega)$, i.e.

$$\exists M_{F_\omega}, \alpha_{F_\omega} > 0 \text{ such that } \|\chi_\omega S_{F_\omega}(t)\|_{L^2(\omega)} \leq M_{F_\omega} e^{-\alpha_{F_\omega} t}$$

and $G_\omega \in \mathcal{L}(U, L^2(\omega))$ and $H_\omega \in \mathcal{L}(\mathcal{O}, L^2(\omega))$. The solution of (3.5) is given by

$$\hat{y}(\xi, t) = S_{F_\omega}(t) \hat{y}_0(\xi) + \int_0^t S_{F_\omega}(t-s) [G_\omega u(s) + H_\omega x(b_i, s)] ds$$

The problem is that, how to observe asymptotically the current state in ω , i.e. to show that under convenient hypothesis, the state of the system (3.5) is an estimator of $T_\omega x(\xi, t)$.

Theorem 3.1. Suppose that the operator F_ω generates a strongly continuous semi-group which is stable on $L^2(\omega)$, then the system (3.5) is ω -observer for (3.1)-(3.2), that is,

$$\lim_{t \rightarrow \infty} \left[T_\omega x(\xi, t) - \hat{y}(\xi, t) \right] = 0, \quad \xi \in \omega$$

if the following conditions hold:

1. There exist $R \in \mathcal{L}(\mathcal{O}, L^2(\omega))$ and $S \in \mathcal{L}(L^2(\omega))$ such that

$$RC + ST_\omega = I \tag{3.6}$$

$$2. \quad \begin{cases} T_\omega \Delta - F_\omega T_\omega = H_\omega C \\ \text{and } G_\omega = T_\omega B. \end{cases} \tag{3.7}$$

Proof: For $y(\xi, t) = T_\omega x(\xi, t)$ and $\hat{y}(\xi, t)$ solution of (3.5), denote $e(\xi, t) = y(\xi, t) - \hat{y}(\xi, t)$.

We have

$$\begin{aligned} \frac{\partial e}{\partial t}(\xi, t) &= \frac{\partial y}{\partial t}(\xi, t) - \frac{\partial \hat{y}}{\partial t}(\xi, t) \\ &= T_\omega \Delta x(\xi, t) + T_\omega B u(t) - F_\omega \hat{y}(\xi, t) - G_\omega u(t) - H_\omega x(b_i, t) \\ &= F_\omega \phi(\xi, t) + [T_\omega \Delta x(\xi, t) - F_\omega T_\omega x(\xi, t) - H_\omega C x(\xi, t)] + [T_\omega B - G_\omega] u(t) \\ &= F_\omega e(\xi, t). \end{aligned}$$

Thus $e(\xi, t) = S_{F_\omega}(t) e(0, t)$ where $e(0, t) = T_\omega x_0(\xi) - \hat{y}_0(\xi)$. Now the stability of the operator F_ω leads to

$$\| e(\cdot, t) \|_{L^2(\omega)} \leq M_F e^{-\alpha_F t} \| T_\omega x_0(\cdot) - \hat{y}_0(\cdot) \|_{L^2(\omega)}$$

therefore $\lim_{t \rightarrow \infty} e(\xi, t) = 0$. Let $\hat{x}(\xi, t) = Rx(b_i, t) + S \hat{y}(\xi, t)$, then we have

$$\begin{aligned} \hat{e}(\xi, t) &= x(\xi, t) - \hat{x}(\xi, t) \\ &= x(\xi, t) - Rx(b_i, t) - S \hat{y}(\xi, t) = S e(\xi, t) \end{aligned}$$

Finally we have $\lim_{t \rightarrow \infty} \hat{x}(\xi, t) = x(\xi, t)$. ■

From this theorem, we can deduce the following statements:

1. This conditions (3.6) and (3.7) in theorem 3.1 guarantee that the dynamical system (3.5) is ω -observer for the system (3.1)-(3.1).
2. A system which is an observer is ω -observer.

3. If a system is ω -observer, then it is ω_I -observer in every subset ω_I of ω , but the converse is not true. This may be proven in the following example:

Example 3.2. Consider the system

$$\begin{cases} \frac{\partial x}{\partial t}(\xi, t) = \gamma_1 \frac{\partial^2 x}{\partial \xi^2}(\xi, t) + \gamma_2 x(\xi, t) &]0, a[, t > 0 \\ x(0, t) = x(a, t) = 0 & t > 0 \\ x(\xi, 0) = x_0(\xi) &]0, a[\end{cases} \quad (3.8)$$

augmented with the output function

$$z(t) = \int_{\Omega} x(\xi, t) \delta(\xi - b) d\xi \quad (3.9)$$

where $\gamma_1 > 0, \gamma_2 > 0, a > 0, \Omega =]0, a[$ and $b \in \Omega$ is the location of the sensor (b, δ_b). The operator $A = \left(\gamma_1 \frac{\partial^2}{\partial \xi^2} + \gamma_2 \right)$ generates a strongly continuous semi-group $(S_A(t))_{t \geq 0}$ on the Hilbert space $L^2(\Omega)$.

Consider the dynamical system

$$\begin{cases} \frac{\partial \hat{y}}{\partial t}(\xi, t) = \gamma_1 \frac{\partial^2 \hat{y}}{\partial \xi^2}(\xi, t) + \gamma_2 \hat{y}(\xi, t) - HC(\hat{y}(\xi, t) - x(\xi, t)) &]0, a[, t > 0 \\ \hat{y}(\eta, t) = 0 & t > 0 \\ \hat{y}(\xi, 0) = \hat{y}_0(\xi) &]0, a[\end{cases} \quad (3.10)$$

where $H \in \mathcal{L}(\mathcal{O}, Y)$, Y is a Hilbert space and $C : Y \rightarrow \mathcal{O}$ is a linear operator. If $b/a \in \cap [0, a]$, then the sensor (b, δ_b) is not strategic for the unstable subsystem of (3.8) and therefore the system (3.8)-(3.9) is not detectable in Ω . Then, the dynamical system (3.46) is not observer for the system (3.8)-(3.9) [7]. We consider the region $\omega = [\alpha, \beta] \subset [0, a]$ (Fig. 3) and the dynamical system.



Figure 3. The domain Ω , the subregion ω and the sensor location b .

$$\begin{cases} \frac{\partial \hat{y}}{\partial t}(\xi, t) = \gamma_1 \frac{\partial^2 \hat{y}}{\partial \xi^2}(\xi, t) + \gamma_2 \hat{y}(\xi, t) - H\omega C(\hat{y}(\xi, t) - x(\xi, t)) &]0, a[, t > 0 \\ \hat{y}(\eta, t) = 0 & t > 0 \\ \hat{y}(\xi, 0) = \hat{y}_0(\xi) &]0, a[\end{cases} \quad (3.11)$$

where $H_\omega \in \mathcal{L}(L^2(\mathcal{O}, \infty, \mathcal{R}^q), L(\omega))$. If $b/a \notin \mathcal{Q} \cap]0, a[$, then the sensor (b, δ_b) is ω -strategic for the unstable subsystem of (3.8) [12] and therefore the system (3.8)-(3.9) is ω -detectable [11], i.e. $\lim_{t \rightarrow \infty} x(\xi, t) = \hat{y}(\xi, t)$. Finally the dynamical system (3.11) is ω -observer for the system (3.8)-(3.9).

3.1.2 Case of zone sensors

In this case, we consider the system (3.1) with the output function (2.4) and we assume that there exists an operator T_ω is such that

$$y(\xi, t) = T_\omega x(\xi, t)$$

So, regional observer may be described by

$$\begin{cases} \frac{\partial \hat{y}}{\partial t}(\xi, t) = F_\omega \hat{y}(\xi, t) + G_\omega u(t) + H_\omega \langle x(\cdot, t), g_i(\cdot) \rangle_{L^2(D_i)} & \mathcal{Q} \\ \hat{y}(\eta, t) = 0 & \Theta \\ \hat{y}(\xi, 0) = \hat{y}_0(\xi) & \Omega \end{cases} \quad (3.12)$$

with solution is represented by the equation

$$\hat{y}(\xi, t) = S_{F_\omega}(t) \hat{y}_0(\xi) + \int_0^t S_{F_\omega}(t-s) [G_\omega u(s) + H_\omega \langle x(\cdot, s), g_i(\cdot) \rangle_{L^2(D_i)}] ds$$

Thus, we obtain the following proposition:

Proposition 3.3. If following conditions hold :

1. The operator F_ω generates a strongly continuous semi-group which is stable on the space $L^2(\omega)$.
2. There exist $\mathcal{R} \in \mathcal{L}(\mathcal{O}, L^2(\omega))$ and $S \in \mathcal{L}(L^2(\omega))$ such that

$$RC + ST_\omega = I$$

$$3. \quad \begin{cases} T_\omega \Delta - F_\omega T_\omega = H_\omega C \\ \text{and } G_\omega = T_\omega B \end{cases}$$

Then, the dynamical system (3.12) is ω -observer for (3.1)-(2.4).

3.1.3 Case of boundary sensors

Here, we consider the system (3.1) augmented with output function (2.6). The related dynamical system may be expressed by the form

$$\begin{cases} \frac{\partial \hat{y}}{\partial t}(\xi, t) = F_\omega \hat{y}(\xi, t) + G_\omega u(t) + H_\omega \langle x(\cdot, t), g_i(\cdot) \rangle_{L^2(\Gamma_i)} & \mathcal{Q} \\ \hat{y}(\eta, t) = 0 & \Theta \\ \hat{y}(\xi, 0) = \hat{y}_0(\xi) & \Omega \end{cases} \quad (3.13)$$

The solution of (3.13) is given by

$$\hat{y}(\xi, t) = S_{F_\omega}(t)\hat{y}_0(\xi) + \int_0^t S_{F_\omega}(t-s)[G_\omega u(s) + H_\omega \langle x(\cdot, s), g_i(\cdot) \rangle_{L^2(\Gamma_i)}] ds$$

Therefore we have the following result:

Proposition 3.4. Under the following conditions :

1. The operator F_ω generates a strongly continuous semi-group which is stable on the space $L^2(\omega)$.
2. There exist $\mathcal{R} \in \mathcal{L}(\mathcal{O}, L^2(\omega))$ and $S \in \mathcal{L}(L^2(\omega))$ such that

$$RC + ST_\omega = I$$

$$3. \quad \begin{cases} T_\omega \Delta - F_\omega T_\omega = H_\omega C \\ \text{and } G_\omega = T_\omega B \end{cases}$$

the dynamical system (3.13) is ω -observer for (3.1)-(2.6).

3.2 Identity ω -observer

In this case, we consider $T_\omega = I$ and $Z = X$, and so the operator equation $T_\omega \Delta - F_\omega T_\omega = H_\omega C$ of the regional observer reduces to $F_\omega = \Delta - H_\omega C$ where A and C are known. Thus, the operator H_ω must be determined such that the operator F_ω is stable. In the case where the sensors are zone types, we consider the system (3.1)-(2.4), together with the dynamical system

$$\begin{cases} \frac{\partial \hat{y}}{\partial t}(\xi, t) = \Delta \hat{y}(\xi, t) + Bu(t) + H_\omega \langle x(\cdot, t), g_i(\cdot) \rangle_{L^2(D_i)} - C \hat{y}(\xi, t) & \mathcal{Q} \\ \hat{y}(\eta, t) = 0 & \Theta \\ \hat{y}(\xi, 0) = \hat{y}_0(\xi) & \Omega \end{cases} \quad (3.14)$$

Thus the sufficient condition of an identity ω -observer (Fig. 4), is formulated in the following proposition :

Proposition 3.5. If there exists a suite of p zones sensors $(D_i, g_i)_{1 \leq i \leq p}$ which is ω -strategic for unstable subsystem of the system (3.1)-(2.4), then the dynamical system (3.14) is an identity ω -observer for (3.1)-(2.4).

Proof: Let us denote $\bar{e}(\xi, t) = y(\xi, t) - \hat{y}(\xi, t)$. Then by deriving $\bar{e}(\xi, t)$, we get

$$\begin{aligned} \frac{\partial \bar{e}}{\partial t}(\xi, t) &= \frac{\partial y}{\partial t}(\xi, t) - \frac{\partial \hat{y}}{\partial t}(\xi, t) \\ &= \Delta x(\xi, t) + Bu(t) - \Delta \hat{y}(\xi, t) - Bu(t) - H_\omega \langle x(\cdot, t), g_i(\cdot) \rangle_{L^2(D_i)} + C \hat{y}(\xi, t) \\ &= \Delta x(\xi, t) - \Delta \hat{y}(\xi, t) - H_\omega C(x(\xi, t) - \hat{y}(\xi, t)) \\ &= (\Delta - H_\omega C)\bar{e}(\xi, t) \end{aligned}$$

Since the sensors $(D_i, g_i)_{1 \leq i \leq p}$ are regionally strategic for unstable subsystem of (3.1)-(2.4), the subsystem is weakly ω -observable, and since it is finite dimensional, then it is exactly ω -observable. Therefore it is ω -detectable [10], there exists an operator $H_\omega \in \mathcal{L}(L^2(0, \infty, \mathcal{R}^q), L^2(\omega))$, such that $(\Delta - H_\omega C)$ generates a strongly continuous, stable semi-group $(S_{H_\omega}(t))_{t \geq 0}$ on the space $L^2(\omega)$ which is satisfied the following:

$$\exists M_\omega, \alpha_\omega > 0 \text{ such that } \|\chi_\omega S_{H_\omega}(t)\|_{L^2(\omega)} \leq M_\omega e^{-\alpha_\omega(t)}$$

Finally, we have

$$\|\bar{e}(\cdot, t)\|_{L^2(\omega)} \leq \|\chi_\omega S_{H_\omega}(t)\|_{L^2(\omega)} \|x_0(\cdot)\| \leq M_\omega e^{-\alpha_\omega(t)} \|x_0(\cdot)\|$$

and therefore $\bar{e}(\xi, t) \rightarrow 0$ when $t \rightarrow \infty$. In this case, the operators $R = 0$ and $S = I$ with $\hat{x}(\xi, t) = \hat{y}(\xi, t)$, then we have

$$\begin{aligned} \hat{e}_I(\xi, t) &= x(\xi, t) - \hat{x}(\xi, t) \\ &= x(\xi, t) - x(\xi, t) + x(\xi, t) - \hat{y}(\xi, t) = \bar{e}(\xi, t) \end{aligned}$$

This lead to $\lim_{t \rightarrow \infty} \hat{x}(\xi, t) = x(\xi, t)$. Then, the system (3.14) is an identity ω -observer for (3.1)-(2.4).

In the case where the sensors are pointwises, we consider the system (3.1)-(2.5) with the corresponding dynamical system

$$\begin{cases} \frac{\partial \hat{y}}{\partial t}(\xi, t) = \Delta \hat{y}(\xi, t) + Bu(t) + H_\omega(x(b_i, t) - C\hat{y}(\xi, t)) & \mathcal{Q} \\ \hat{y}(\eta, t) = 0 & \Theta \\ \hat{y}(\xi, 0) = \hat{y}_0(\xi) & \Omega \end{cases} \quad (3.15)$$

may be considered as an identity ω -observer. So, we have the following result:

Proposition 3.6. If there exists a suite of p pointwise sensors $(b_i, \delta_{b_i})_{1 \leq i \leq p}$ which is ω -strategic for unstable subsystem of the system (3.1)-(2.5), then the dynamical system (3.15) is an identity ω -observer for (3.1)-(2.5).

In the case where the sensors are boundary zones, we also consider the system (3.1) together with output function (2.6). Then the system

$$\begin{cases} \frac{\partial \hat{y}}{\partial t}(\xi, t) = \Delta \hat{y}(\xi, t) + Bu(t) + H_\omega(\langle x(\cdot, t), g_i(\cdot) \rangle_{L^2(\Gamma_i)} - C\hat{y}(\xi, t)) & \mathcal{Q} \\ \hat{y}(\eta, t) = 0 & \Theta \\ \hat{y}(\xi, 0) = \hat{y}_0(\xi) & \Omega \end{cases} \quad (3.16)$$

may be consider as ω -observer for (3.1)-(2.6). Then we have the following result:

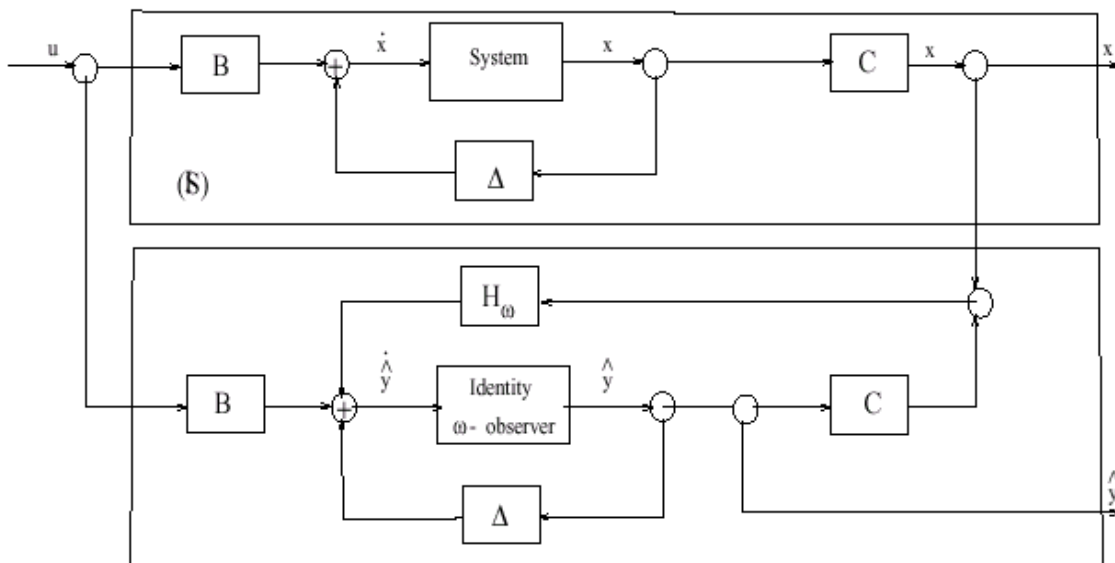

Figure 4. Identity ω-observer.

Proposition 3.7. If there exists a suite of p boundary zones sensors $(\Gamma_i, g_i)_{1 \leq i \leq p}$ which is ω -strategic for unstable subsystem of the system (3.1)-(2.6), then the dynamical system (3.16) is an identity ω -observer for (3.1)-(2.6).

3.3 Application to an identity ω -observer in diffusion system

Consider the case of two dimensional system defined in $\Omega =]0, 1[\times]0, 1[$ by the parabolic equation

$$\begin{cases} \frac{\partial x}{\partial t}(\xi_1, \xi_2, t) = \frac{\partial^2 x}{\partial \xi_1^2}(\xi_1, \xi_2, t) + \frac{\partial^2 x}{\partial \xi_2^2}(\xi_1, \xi_2, t) + x(\xi_1, \xi_2, t) & \mathcal{Q} \\ x(\zeta, \eta, t) = 0 & \Theta \\ x(\xi_1, \xi_2, 0) = x_0(\xi_1, \xi_2) & \Omega \end{cases} \quad (3.17)$$

and suppose there is only one boundary zone sensor (Γ, g) located on $\Gamma =]\eta_{01} - l_1, 1[\times \{0\} \cup \{1\} \times]0, \eta_{02} + l_2[\subset \partial\Omega$. The sensor (Γ, g) may be sufficient for the measurement part of the desired state [17]. In this case the output function is given by

$$z(t) = \int_{\Gamma} x(\zeta, \eta, t)g(\zeta, \eta)d\zeta d\eta. \quad (3.18)$$

and the considered subregion $\omega =]\alpha_1, \beta_1[\times]\alpha_2, \beta_2[\subset \Omega =]0, 1[\times]0, 1[$, (see Fig. 5).

The eigenfunctions related to the operator $\left(\frac{\partial^2}{\partial \xi_1^2} + \frac{\partial^2}{\partial \xi_2^2} + 1 \right)$ are given by

$$\varphi_{nm}(\xi_1, \xi_2) = \frac{2}{\sqrt{(\beta_1 - \alpha_1)(\beta_2 - \alpha_2)}} \sin n\pi \left(\frac{\xi_1 - \alpha_1}{\beta_1 - \alpha_1} \right) \sin m\pi \left(\frac{\xi_2 - \alpha_2}{\beta_2 - \alpha_2} \right)$$

associated with eigenvalues

$$\lambda_{nm} = 1 - \left(\frac{n^2}{(\beta_1 - \alpha_1)^2} + \frac{m^2}{(\beta_2 - \alpha_2)^2} \right) \pi^2.$$

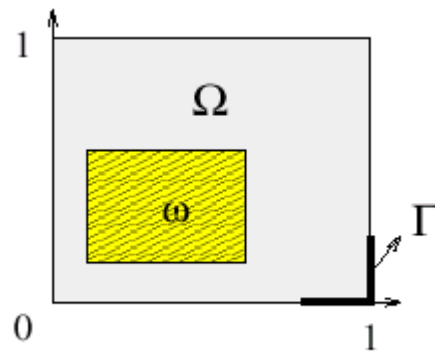

Figure 5. The domain Ω , the subregion ω and the sensor location Γ .

By applying the proposition 3.7, the system

$$\begin{cases} \frac{\partial y}{\partial t}(\xi_1, \xi_2, t) = \frac{\partial^2 y}{\partial \xi_1^2}(\xi_1, \xi_2, t) + \frac{\partial^2 y}{\partial \xi_2^2}(\xi_1, \xi_2, t) \\ \quad + y(\xi_1, \xi_2, t) + H_\omega(z(t) - Cy(\xi_1, \xi_2, t)) & \mathcal{Q} \\ y(\zeta, \eta, t) = 0 & \Theta \\ y(\xi_1, \xi_2, 0) = y_0(\xi_1, \xi_2) & \Omega \end{cases} \quad (3.19)$$

is an identity ω -observer for the system (3.17)-(3.18) if

$$\int_{\Gamma} x(\zeta, \eta, t)g(\zeta, \eta)d\zeta d\eta \neq 0.$$

This leads to $(\eta_{01} - \alpha_1) / (\beta_1 - \alpha_1)$ and $(\eta_{02} - \alpha_2) / (\beta_2 - \alpha_2) \in \mathcal{N}$ for every $n, m = 1, \dots, J$, and hence the boundary sensor (Γ, g) is ω -strategic.

3.4 Reduced-order ω -observer

In the case where the output function (2.2) gives information about a part of the state vector $x(\xi, t)$, it is necessary to define an asymptotic observer enables to construct the unknown part of the state. Consider now $X = X_1 \oplus X_2$ where X_1 and X_2 are subspaces of X . Under the hypothesis of section 2, the system (2.1) can be decomposed by:

$$\Delta = \begin{bmatrix} \Delta_{11} & \Delta_{12} \\ \Delta_{21} & \Delta_{22} \end{bmatrix}, \quad x = \begin{bmatrix} x_1 \\ x_2 \end{bmatrix}, \quad B = \begin{bmatrix} B_1 \\ B_2 \end{bmatrix} \quad (3.20)$$

where $x_1 \in X_1$, $x_2 \in X_2$, $B_1 \in \mathcal{L}(Z_1, U)$ and $B_2 \in \mathcal{L}(X_2, U)$. Using the decomposition of (3.20), the system (3.1) can be written by the form

$$\begin{cases} \frac{\partial x_1}{\partial t}(\xi, t) = \Delta_{11}x_1(\xi, t) + \Delta_{12}x_2(\xi, t) + B_1u(t) & \mathcal{Q} \\ x_1(\eta, t) = 0 & \Theta \\ x_1(\xi, 0) = x_{0_1}(\xi) & \Omega \end{cases} \quad (3.21)$$

and

$$\begin{cases} \frac{\partial x_2}{\partial t}(\xi, t) = \Delta_{21}x_1(\xi, t) + \Delta_{22}x_2(\xi, t) + B_2u(t) & \mathcal{Q} \\ x_2(\eta, t) = 0 & \Theta \\ x_2(\xi, 0) = x_{2_0}(\xi) & \Omega \end{cases} \quad (3.22)$$

Now we discuss this problem with various sensors. Thus in the case of pointwise sensors the system (3.21)-(3.22) augmented with output function.

$$z(t) = x_1(b_i, t) \quad (3.23)$$

In this section, the problem consists in constructing ω -observer which enables to estimate the unknown part $x_2(\xi, t)$. Equivalently, the problem is reduced to define an identity ω -observer for the system (3.22). The equations (3.22)-(3.23) allow the following system.

$$\begin{cases} \frac{\partial a}{\partial t}(\xi, t) = \Delta_{22}a(\xi, t) + [B_2u(t) + \Delta_{21}x(b_i, t)] & \mathcal{Q} \\ a(\eta, t) = 0 & \Theta \\ a(\xi, 0) = a_0(\xi) & \Omega \end{cases} \quad (3.24)$$

with the output function

$$\bar{z}(\xi, t) = A_{12}a(\xi, t) \quad (3.25)$$

From the proposition 3.6, we have an identity ω -observer for the system (3.24)-(3.25) given by

$$\begin{cases} \frac{\partial \hat{y}}{\partial t}(\xi, t) = \Delta_{22}\hat{y}(\xi, t) + [B_2u(t) + \Delta_{21}x(b_i, t)] \\ \quad + H_\omega[\bar{z}(\xi, t) - \Delta_{12}\hat{y}(\xi, t)] & \mathcal{Q} \\ \hat{y}(\eta, t) = 0 & \Theta \\ \hat{y}(\xi, 0) = \hat{y}_0(\xi) & \Omega \end{cases} \quad (3.26)$$

If the sensors $(D_i, g_i)_{1 \leq i \leq p}$ are ω -strategic for the subsystem (3.21)-(3.23) and this result gives the following relation:

$$1. \quad p \geq r \quad (3.27)$$

$$2. \quad \text{rank } G_n = r_n, \quad \forall n, n = 1, \dots, J \quad \text{with } G = (G_n)_{ij} = \varphi_{n_j}(b_i) \quad (3.28)$$

where $\sup r_n = r < \infty$ and $j = 1, \dots, r_n$. Thus we have the following theorem:

Theorem 3.8. If the sensors $(D_i, g_i)_{1 \leq i \leq p}$ are ω -strategic for the unstable subsystem (3.21)-(3.23), then

$$\lim_{t \rightarrow \infty} [\psi(\xi, t) + H_\omega x(b_i, t) - x_2(\xi, t)] = 0, \quad \forall \xi \in \omega$$

where $x(b_i, t)$ is the output of the initial system and w is the solution of equation

$$\begin{cases} \frac{\partial \psi}{\partial t}(\xi, t) = (\Delta_{22} - H_\omega \Delta_{12})\psi(\xi, t) + [\Delta_{22}H_\omega - H_\omega \Delta_{12}H_\omega \\ \quad - H_\omega \Delta_{11} + \Delta_{21}]x(b_i, t) + [B_2 - H_\omega B_1]u(t) & \mathcal{Q} \\ \psi(\eta, t) = 0 & \Theta \\ \psi(\xi, 0) = \psi_0(\xi) & \Omega \end{cases}$$

Proof: The solution of the identity ω -observer (3.26) is given by

$$\hat{y}(\xi, t) = S_{H_\omega}(t)\hat{y}_0(\xi) + \int_0^t S_{H_\omega}(t-s)[B_2u(s) + \Delta_{21}x(b_i, s) + H_\omega \bar{z}(\xi, s)]ds \quad (3.29)$$

From the equations (3.21) and (3.25), we have

$$\bar{z}(\xi, t) = \Delta_{12}a(\xi, t) = \frac{\partial x_1}{\partial t}(\xi, t) - \Delta_{11}x_1(\xi, t) - B_1u(t) \quad (3.30)$$

Inserting (3.30) into (3.29), we obtain

$$\begin{aligned} \hat{y}(\xi, t) &= S_{H_\omega}(t)\hat{y}_0(\xi) + \int_0^t S_{H_\omega}(t-s)H_\omega \frac{\partial x_1}{\partial t}(\xi, s)ds + \int_0^t S_{H_\omega}(t-s)[B_2u(s) \\ &\quad + \Delta_{21}x(b_i, s) - H_\omega \Delta_{11}x_1(\xi, s) - H_\omega B_1u(s)]ds \end{aligned} \quad (3.31)$$

and we can get

$$\begin{aligned} \int_0^t S_{H_\omega}(t-s)H_\omega \frac{\partial x_1}{\partial t}(\xi, s)ds &= H_\omega x_1(\xi, t) - S_{H_\omega}(t)H_\omega x_{10}(\xi) \\ &\quad + (\Delta_{22} - H_\omega A_{12}) \int_0^t S_{H_\omega}(t-s)H_\omega x_1(\xi, s)ds \end{aligned} \quad (3.32)$$

Using Bochner integrability properties and closeness of $(A_{22} - H_\omega A_{12})$, the equation (3.32) becomes

$$\int_0^t S_{H_\omega}(t-s)H_\omega \frac{\partial x_1}{\partial t}(\xi, s)ds = H_\omega x_1(\xi, t) - S_{H_\omega}(t)H_\omega x_{01}(\xi) + \int_0^t S_{H_\omega}(t-s)(\Delta_{22} - H_\omega \Delta_{12})H_\omega x_1(\xi, s)ds \quad (3.33)$$

Substituting (3.33) into (3.31), we have

$$\begin{aligned} \hat{y}(\xi, t) &= S_{H_\omega}(t)\hat{y}_0(\xi) - S_{H_\omega}(t)H_\omega x_{01}(\xi) + H_\omega x_1(\xi, t) \\ &+ \int_0^t S_{H_\omega}(t-s)[\Delta_{22}H_\omega - H_\omega A_{12}H_\omega - H_\omega \Delta_{11} + \Delta_{21}]x_1(\xi, s)ds \\ &+ \int_0^t S_{H_\omega}(t-s)[B_2 - H_\omega B_1]u(s) \end{aligned} \quad (3.34)$$

Setting $\psi(\xi, t) = \hat{y}(\xi, t) + H_\omega x(b, t)$, with $\psi_0(\xi) = \hat{y}_0 + H_\omega x_{01}(\xi)$, where $z_0(\xi) = x_{01}(\xi)$. Now, assume that $(\Delta_{22}H_\omega - H_\omega \Delta_{12}H_\omega - H_\omega \Delta_{11} + \Delta_{21})$ and $(B_2 - H_\omega B_1)$ are strongly continuous, the equation (3.34) can be differentiated to yield the following system

$$\begin{cases} \frac{\partial \psi}{\partial t}(\xi, t) = (\Delta_{22} - H_\omega \Delta_{12})\psi(\xi, t) + (A_{22}H_\omega - H_\omega \Delta_{12}H_\omega - H_\omega \Delta_{11} + \Delta_{21})x(b_i, t) + (B_2 - H_\omega B_1)u(t) & \mathcal{Q} \\ \psi(\eta, t) = 0 & \Theta \\ \psi(\xi, 0) = \psi_0(\xi) & \Omega \end{cases} \quad (3.35)$$

and therefore

$$\begin{aligned} \frac{\partial y}{\partial t}(\xi, t) - \frac{\partial x_2}{\partial t}(\xi, t) &= (\psi(\xi, t) + H_\omega x(b_i, t)) - x_2(\xi, t) \\ &= (\Delta_{22}\hat{y}(\xi, t) + B_2u(t) + \Delta_{21}x(b_i, t) + H_\omega(\tilde{z}(\xi, t) - \Delta_{12}\hat{x})(\xi, t) - \Delta_{21}x_1(\xi, t) - \Delta_{22}x_2(\xi, t) - B_2u(t) \\ &= (\Delta_{22} - H_\omega \Delta_{12})(\hat{y}(\xi, t) - x_2(\xi, t)) \end{aligned}$$

From the relation (3.27) and (3.28), we can deduce that the system (3.24)-(3.25) is ω -detectable [11], there exists an operator $H_\omega \in \mathcal{L}(\mathcal{O}, L^2(\omega))$, such that $(A_{22} - H_\omega A_{12})$ generates a stable semi-group $(S_{H_\omega}(t))_{t \geq 0}$ on the space $L^2(\omega)$:

$$\exists M_{H_\omega}, \alpha_{H_\omega} > 0 \text{ such that } \|\chi_\omega S_{H_\omega}(t)\|_{L^2(\omega)} \leq M_{H_\omega} e^{-\alpha_{H_\omega} t}$$

Thus we obtain

$$\begin{aligned} \|\hat{y}(\cdot, t) - x_2(\cdot, t)\|_{L^2(\omega)} &\leq \|\chi_\omega S_{H_\omega}(t)\|_{L^2(\omega)} \|\hat{y}(\cdot, 0) - x_2(\cdot, 0)\|_{L^2(\omega)} \\ &\leq M_{H_\omega} e^{-\alpha_{H_\omega}(t)} \|\hat{y}(\cdot, 0) - x_2(\cdot, 0)\|_{L^2(\omega)} \longrightarrow 0 \\ &\text{as } t \longrightarrow \infty. \end{aligned}$$

In this case, $\hat{x}(\xi, t) = y_2(\xi, t)$, then we have

$$\begin{aligned} \bar{e}(\xi, t) &= \psi(\xi, t) + H_\omega x(b_i, t) - x_2(\xi, t) \\ &= \psi(\xi, t) + H_\omega x(b_i, t) - x_2(\xi, t) + x_2(\xi, t) - x_2(\xi, t) \\ &= \psi(\xi, t) + H_\omega x(b_i, t) - \hat{x}_2(\xi, t) \end{aligned}$$

and hence $\lim_{t \rightarrow \infty} \hat{x}_2(\xi, t) = x_2(\xi, t)$. ■

Then, from this result, we have:

1. The state vector $\hat{y}_2(\xi, t)$ can be represented by

$$\hat{y} = \begin{bmatrix} \hat{y}_1 \\ \hat{y}_2 \end{bmatrix} = \begin{bmatrix} x \\ \psi + H_\omega x \end{bmatrix}$$

which estimates asymptotically the state vector

$$x = \begin{bmatrix} x_1 \\ x_2 \end{bmatrix}.$$

2. The component $\hat{y}_2(\xi, t)$ is an asymptotically estimator of $x_2(\xi, t)$.
3. The system (3.26) is a reduced-order ω -observer for the system (3.24)-(3.25) (Fig. 6).
4. If we consider $X_1 = L^2(0, \infty; \mathcal{R}^p)$ and $X_2 = Y$ where Y is the state space for the ω -observer. So, from the theorem 3.8, the reduced-order ω -observer can reconstruct the unknown state components $(x_{p+1}, x_{p+2}, \dots)$, thus the condition (3.7) of the theorem 3.1 is satisfied, if we define the following operators as below.

$$S = [0 \ I_{z_1}], \quad R = [I_{z_1} \ H_\omega], \quad T_\omega = \begin{bmatrix} H_\omega \\ I_{z_1} \end{bmatrix} \text{ and } C = \begin{bmatrix} I_{z_1} \\ 0 \end{bmatrix}$$

and we obtain the relation $RC + ST_\omega = I_{z_1}$.

In the case of zone sensors, we consider the system (3.21)- (3.22) augmented with output function

$$z(\cdot, t) = \langle x_1(\cdot, t), g_i(\cdot) \rangle_{L^2(D_i)} \quad (3.36)$$

The equations (3.22)-(3.36) lead to the following system

Proposition 3.9. The dynamical system (3.39) is a reduced-order ω -observer, if there exists a suite of p zone sensors $(D_i, g_i)_{1 \leq i \leq p}$, which is ω -strategic for unstable subsystem of the original system.

The case of boundary pointwise sensors is similar to the case pointwise sensors. In the case of boundary zone sensors, we consider again the equations (3.21) and (3.22) with the output function

$$z(., t) = \langle x_1(., t), g_i(\cdot) \rangle_{L^2(\Gamma_i)} \quad (3.40)$$

The equation (3.22)-(3.40) leads to

$$\begin{cases} \frac{\partial \hat{a}}{\partial t}(\xi, t) = \Delta_{22} \hat{a}(\xi, t) + [B_2 u(t) + \Delta_{21} \langle x_1(., t), g_i(\cdot) \rangle_{L^2(\Gamma_i)}] & \mathcal{Q} \\ \hat{a}(\eta, t) = 0 & \Theta \\ \hat{a}(\xi, 0) = \hat{a}_0(\xi) & \Omega \end{cases} \quad (3.41)$$

with the output function

$$\bar{z}(\xi, t) = \Delta_{12} \hat{a}(\xi, t) \quad (3.42)$$

From proposition 3.7 can be characterized an identity ω -observer for the system (3.41)-(3.42) given by

$$\begin{cases} \frac{\partial \hat{y}}{\partial t}(\xi, t) = \Delta_{22} \hat{y}(\xi, t) + [B_2 u(t) + \Delta_{21} \langle x_1(., t), g_i(\cdot) \rangle_{L^2(\Gamma_i)}] \\ \quad + H_\omega [\bar{z}(\xi, t) - \Delta_{12} \hat{y}(\xi, t)] & \mathcal{Q} \\ \hat{y}(\eta, t) = 0 & \Theta \\ \hat{y}(\xi, 0) = \hat{y}_0(\xi) & \Omega \end{cases} \quad (3.43)$$

If the sensors $(D_i, g_i)_{1 \leq i \leq p}$ are ω -strategic for the subsystem (3.21)-(3.42) and this result gives the following relation

1. $p \geq r$
2. $\text{rank } G_i = r_i, \quad \forall i, i = 1, \dots, J$ with $G = (G_n)_{ij} = \langle \varphi_{n_j}(\cdot), g_i(\cdot) \rangle_{L^2(\Gamma_i)}$

where $\sup r_n = r < \infty$ and $j = 1, \dots, r_n$.

Proposition 3.10. The dynamical system (3.43) is a reduced-order ω -observer, if there exist a suite of boundary zone sensors $(\Gamma_i, g_i)_{1 \leq i \leq p}$ which is ω -strategic for unstable subsystem of the original system.

These results can be extended to the case of Neumann boundary conditions.

3.5 Application to a reduced-order ω -observer in diffusion systems

Consider the case of one dimensional system described by the parabolic equation

$$\begin{cases} \frac{\partial \Psi}{\partial t}(\xi, t) = \Delta \Psi(\xi, t) &]0, 1[, t > 0 \\ \Psi(0, t) = \Psi(1, t) = 0 & t > 0 \\ \Psi(\xi, 0) = \Psi_0(\xi) &]0, 1[\end{cases} \quad (3.44)$$

Suppose that information retrieved by p pointwise sensors. The output function is given

$$z(t) = \left[\int_0^1 \Psi(\xi, t) \delta(\xi - b_1) d\xi, \dots, \int_0^1 \Psi(\xi, t) \delta(\xi - b_p) d\xi \right]^{tr} \quad (3.45)$$

where $\Omega =]0, 1[$ and $(b_i)_{1 \leq i \leq p} \in \Omega$ are the pointwise sensors locations (Fig. 7).

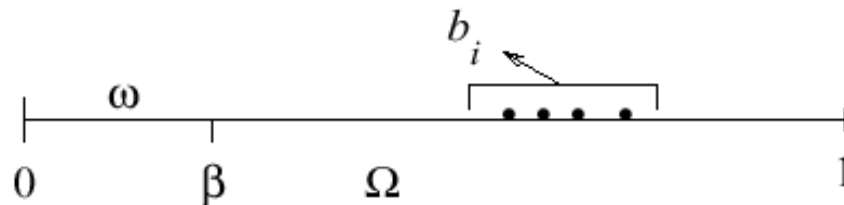

Figure 7. The domain Ω , the subregion ω and the location b_i of the pointwise sensor.

The output function (3.45) gives the first p components of the state vector $\Psi(\xi, t)$. Thus the residue components

$$\int_0^1 \Psi(\xi, t) \delta(\xi - b_i) d\xi \quad \forall i \geq p+1$$

may be constructed asymptotically the second part of the state vector. For this purpose, consider the subregion $\omega =]0, \beta[\subset]0, 1[$ and the eigenfunctions of the operator Δ related to ω are defined by

$$\varphi_n(\xi) = \sqrt{\frac{2}{\beta}} \sin n\pi \left(\frac{\xi}{\beta} \right)$$

In this case, the operator $B = 0$, $\Delta_{12} = \Delta_{21} = 0$ and

$$\begin{aligned} \Delta_{11} &= \text{diag}(\lambda_1, \lambda_2, \dots, \lambda_q) \\ \Delta_{22} &= \text{diag}(\lambda_{q+1}, \lambda_{q+2}, \dots) \end{aligned}$$

The system (3.44)-(3.45) is equivalent to the system (2.1)-(2.2). The associated eigenvalues $\lambda_n = \left(\frac{n\pi}{\beta} \right)^2$ with $\lambda_1 > \lambda_2 > \dots > \lambda_j > 0 > \lambda_{j+1} > \dots$. The theorem 3.8 allow to estimate the unknown

components Ψ asymptotically where $\bar{\Psi} = \Psi_{p+1}, \Psi_{p+2}, \dots$. If the sensors are ω -strategic for the unstable par of the subsystem with Δ_{11} . That means, the following the relation holds:

1. $p \geq \sup r_n \Rightarrow p = 1$
2. $\int_0^1 \Psi(\zeta, t) \delta(\zeta - b_i) d\xi \neq 0, \quad \forall i, q < i \leq J$

then, we obtain $\lim_{t \rightarrow \infty} \left[\left(\psi(\xi, t) + H_\omega \Psi(b_i, t) - \bar{\Psi}(\xi, t) \right) \right] = 0, \quad \forall \xi \in \omega$ with

$$\begin{cases} \frac{\partial \psi}{\partial t}(\xi, t) = \Delta_{22} \psi(\xi, t) + (\Delta_{22} H_\omega - H_\omega \Delta_{11}) \Psi(b_i, t) &]0, 1[, t > 0 \\ \psi(\eta, t) = 0 & t > 0 \\ \psi(\xi, 0) = \psi_0(\xi) &]0, 1[\end{cases}$$

and so, for $p \leq J$ the components of the unstable modes of the output function are required to be non-zero, and for $p > J$, the sensors are also strategic for the subsystem with Δ_{11} . Finally the dynamical system

$$\begin{cases} \frac{\partial \phi}{\partial t}(\xi, t) = \Delta_{22} \phi(\xi, t) - H_\omega C \bar{z}(\xi, t) &]0, 1[\times]0, 1[, t > 0 \\ \phi(\eta, t) = 0 & t > 0 \\ \phi(\xi, 0) = \phi_0(\xi) &]0, 1[\times]0, 1[\end{cases} \quad (3.46)$$

is a reduced ω -observer for the system (3.44)-(3.45).

4. Conclusion

In this paper we have studied the concept of ω -observer, of a distributed diffusion system whose behavior is expressed in the terms of infinite-dimensional system. More precisely, we have given an extension of asymptotic regional state reconstruction in the considered subregion ω , based on the structures of sensors. Thus, we have characterized the existence of such ω -observer (general case, identity, reduced-order). The case where the state to be asymptotically estimated on a part of boundary of the domain Ω is under consideration.

References

1. Gressang, R.; Lamont, G. B. Observers for systems characterized by semi-groups. *IEEE on Automatic and Control* **1975**, *20*, 523-528.
2. Kitamura, S.; Sakairi, S.; Nishimura, M. Observer for distributed-parameter diffusion systems. *Electrical engineering in Japan* **1972**, *92*, 142-149.
3. Hautus, M. L. Strong detectability and observers. *Linear Algebra and its Applications* **1983**, *5*, 353-368.
4. El Jai, A.; Berrahmoune, L. Localisation d'actionneurs-zones pour la controlabilite de systemes paraboliques. *C. R. Acad. Sc.* **1983**, *297*, 647-650.
5. El Jai, A.; Berrahmoune, L. Localisation d'actionneurs ponctuels pour la controlabilite de systemes paraboliques. *C. R. Acad. Sc.* **1984**, *298*, 47-50.
6. El Jai, A.; Berrahmoune, L. Localisation d'actionneurs-frontiere pour la controlabilite de systemes paraboliques. *C. R. Acad. Sc.* **1984**, *298*, 177-180.
7. El Jai, A.; Pritchard, A. J. *Sensors and controls in the analysis of distributed systems*; Ellis Horwood series in Mathematics and its Applications, Wiley : New York, 1988.
8. El Jai, A.; Zerrik, E.; Simon, M. C.; Amouroux, M. Regional observability of a thermal process. *IEEE Trans. on Automatic Control* **1995**, *40*, 518-521.
9. El Jai, A.; Guisset, E.; Trombe, A.; Suleiman, A. Application of boundary observation to a thermal system. Conf. of MTNS 2000, Perpignan, France, June 19-23.
10. Al-Saphory, R.; El Jai, A. Asymptotic regional state reconstruction. *Int. J. of Systems Science* **2000** submitted.
11. Al-Saphory, R.; El Jai, A. Sensors structures and regional detectability of parabolic distributed systems. *Sensors and Actuators* **2001**, *29*, 163-171.
12. El Jai, A.; Simon, M. C.; Zerrik, E. Regional observability and sensor structures. *Sensors and Actuators* **1993**, *39*, 95-102.
13. Al-Saphory, R.; El Jai, A. Sensors characterizations for regional boundary detectability of distributed parameter systems. *Sensors and Actuators* **2001**, *94*, 1-10.

Sample Availability: Available from the author.

© 2001 by MDPI (<http://www.mdpi.net>). Reproduction is permitted for noncommercial purposes.