

**NASA Technical Memorandum 81685**

(NASA-TM-81685) SERT II 1980 EXTENDED  
FLIGHT THRUSTER EXPERIMENTS (NASA) 27 p  
HC A03/MF A01 CSCL 21C

N81-19222

Unclas  
G3/20 41728

# Sert II 1980 Extended Flight Thruster Experiments

W. R. Kerslake and L. R. Ignaczak  
*Lewis Research Center*  
*Cleveland, Ohio*



Prepared for the  
Fifteenth International Electric Propulsion Conference  
cosponsored by the American Institute of Aeronautics and Astronautics,  
the Japan Society for Aeronautical and Space Sciences,  
and Deutsche Gessellschaft fur Luft- und Raumfahrt  
Las Vegas, Nevada, April 21-23, 1981

**NASA**

## SERT II 1980 EXTENDED FLIGHT THRUSTER EXPERIMENTS

by W. R. Kerslake and L. R. Ignaczak

National Aeronautics and Space Administration  
Lewis Research Center  
Cleveland, Ohio 44135

### Abstract

The SERT II spacecraft, launched in 1970, has been maintained in an operational, but intermittent status since 1971. This paper presents the flight results obtained from mid 1979 through December 1980. Near continuous solar power in 1979 and 1980 has enabled long periods of thruster endurance testing. Three of four propellant tanks have been exhausted with no significant change in thruster system operation before being empty. A new plasma mode thrust has been characterized and direct thrust measurements obtained. Other tests, including beam neutralization by various neutralizer sources, give insight to electron conduction across plasmas in space and provide a basis to model neutralization of thruster arrays.

### Introduction

The Space Electric Rocket Test II (SERT II) spacecraft was launched in 1970 with a primary objective of demonstrating long-term operation of a space electric thruster system<sup>1</sup>. Progress towards that objective was completed late in 1970 when each of two ion thruster systems on board developed a high-voltage grid short. The continuing functional state of the spacecraft has permitted an expansion of the original scope of mission to include demonstration of ion thruster system space storage, restartability, and steady state operation<sup>2</sup>, and the study of plasma efflux between two thruster systems<sup>3</sup>. These added tests were possible since the spacecraft returned to a continuous sunlight orbit on January 11, 1979 and continuous power is available to perform testing until April 1981 (est.).

This paper presents the results of SERT II experiments conducted in the period of mid 1979 to December 1980. These results include: (1) verification of flow rates measured on earth in vacuum tanks with flow rates measured on board SERT II; (2) thruster system operating characteristics (startup or steady state) remained stable during this operation; (3) identification of a plasma thrust mode (H.V. off) of the discharge chamber and obtaining direct thrust measurements of this mode; (4) operating an ion beam while emitting neutralizing electrons from various sources; and (5) operating an ion thruster with no on-board neutralizer emitter.

During the period of December 1980 to April 1981, thruster system 2 is planned for plasma mode operation to obtain further discharge chamber endurance operation and exhaust the main propellant tank to obtain confirmation of its flow rate. In April 1981, the spacecraft orbit will enter an era of partial shadowing for eight years (except October-November 1981). In 1989 continuous sunlight orbits would again occur. No plans presently exist for any spacecraft testing past April 1981.

### Nomenclature

I	current, mA
$n_i$	ion plasma density, ions/cm <sup>3</sup>
Neut	neutralizer
Main	main discharge of thruster
S/A	solar array
S/C	spacecraft
Supply 4	main discharge
Supply 5	screen (beam) current (i.e., 2-I5 is beam current of T/S-2)
Supply 6	accel grid
Supply 7	neut keeper
Supply 9	neut bias
Supply 10	main keeper
T/S-1	thruster system 1
T/S-2	thruster system 2
V	voltage, v
V <sub>s</sub>	space plasma potential (assumed = zero v)

### Apparatus and Procedure

The SERT II spacecraft is shown in Fig. 1. It consists of an Agena stage rocket with a 1.5-kW solar array on one end and two experimental ion thruster systems on the opposite end. Further description of the spacecraft and its operation may be found in Refs. 2 to 4. A thruster system contains an ion thruster together with Hg-loaded propellant tanks mounted on gimbals. A thruster power conditioning and control box is located inside the spacecraft body. Each thruster system has a hot-wire probe that can be swept through the ion exhaust beam and measure its plasma potential profile. The following sections describe this hardware and operating conditions in detail.

### Thruster Systems

The steady-state SERT II thruster operation at various times since 1970 is summarized in Ref. 2 and Table 1 and 2. The information below gives normal thruster operation applicable to the data of this paper. The two thruster systems were identical in electrical and mechanical design.

T/S-1. - Data were attained with this thruster completely off, with the neutralizer discharge only lit, and with both the main and neutralizer discharges lit. Figure 2 shows a schematic wiring diagram of thruster power supplies and solar array. Various set points of operation may be found in data tables of this paper. The screen (I-V5) to accel grid (I-V6) short developed in 1970 remains, and prevented these supplies from turning on without current overload. The telemetry current return to S/C ground, however, remains functional when the supplies are off. The I5 current reads electron return to S/C ground or ions leaving the thruster. If a net flow of electrons should leave the thruster, the I5 current would read zero. The I6 current reads electrons flowing from S/C ground to the accel grid due to ion impingement. If a net

flow of electrons should strike the accel grid, the I6 current would read zero. With the V6 supply turned off, the impedance to electrons flowing from S/C ground through the supply causes the accel grid to become 10 v. positive for 0.1 mA current, 29 v. positive for 6 mA, and 47 v. positive for 22 mA.

T/S-2. - For the tests described herein, the beam current of thruster 2 was maintained at 85±3 mA or 200±3 mA by closed-loop control. The screen voltage was 3000 v and the accel grid was -1500 v. for 85 mA beam. The data tables give operating values of other parameters, such as when T/S-2 was operated in a plasma thruster mode (H.V. off, main discharge on.)

V9 bias supply. - The V9 supply was designed to place a bias voltage between the neutralizer cathode and S/C ground. In addition to zero voltage, there are four nominal bias voltages: ±25 v and ± 50 v. The common of the bias supply is connected to S/C ground and the output then drives the neutralizer cathode either (+) or (-) with respect to the S/C frame. The bias voltages were generated by flowing current across a zener diode stack with voltage magnitude and polarity changes made by a command switching network. Current to produce negative bias was produced internally within the supply, but neutralizer emission current was required to produce positive bias. At times, when there was little or no neutralizer emission, the nominal positive V9 voltage did not appear on the neutralizer. The I9 telemetry read emitted electron current from S/C ground through the neutralizer cathode to space plasma. If electron flow was in the opposite direction, I9 telemetry would read zero.

#### Hot-Wire Probes

The SERT II spacecraft was designed with three hot-wire emissive probes to measure plasma potentials<sup>5</sup>. One probe, which burned out in 1971, was at the end of a 1.5-meter long beam protruding ahead of the S/C body. The other two probes were each at the end of an arm that rotated it into and out of each ion beam. The two beam probes are shown in Fig. 3. Beam probe 1 was jammed and remained stationary in a position fully away from the beam center, but was electrically operative. The probe voltages listed in tables are data as received from the S/C and are relative to S/C frame. All plasma potentials shown on figures are relative to space plasma potential which is assumed zero.

Beam probe 2 functioned normally. When commanded, it began rotating and was heated at the same time. The telemetry system sampled the probe potential reading every 4 seconds. Fifty seconds were required to make one sweep. Possible probe reading positions are shown in Fig. 3. As the "probe-on" command and telemetry sampling times were not synchronized the positions of readings are not always those shown in Fig. 3. One sampling, however, must always occur in the ion beam. Micro switches stop, reverse sweep direction, and turn off the probe at each end of travel, leaving an arc of 60° not traversed by the probe 2 sweep. Further details of probe operation may be found in Ref. 3 or 5.

#### Solar Array

Description and 1979 performance curves for the SERT II main solar array (S/A) are presented in Ref. 2. The 1430-W (beginning of life, BOL) array was degraded to about 63 percent of BOL maximum power and this power limit prevented cross neutralization operation at ion beam currents greater than 85 mA. For all tests the negative side of the S/A was connected to S/C ground. S/A operating voltages are listed in Table 2 and the small voltage variation is due to load change and voltage degradation.

The solar array was loaded to maximum power several times in 1980. These tests showed, within data accuracy (±2 percent), little change from data taken in 1979 (2). This is to be expected from a solar array that has been in orbit over 10 years and was on the "flat" portion of its degradation curve.

#### Telemetry Data Accuracy

All S/C data is in the form of 0 to 63 counts, but each parameter has its own scale factor. The list below give the value of 1 count change in each parameter. The uncertainty is ±0.5 count. Some of the values in Table 2 fall between counts due to a time averaging of the data. There is also uncertainty in the data of Table 2 due to the updating sequence of the telemetry. For example, I5 and I6 update every 30 seconds, but I9 and V9 update only once per minute. The probe voltages update every 4 seconds.

#### Spacecraft Telemetry Values

Parameter	1-Count value
I5	5 mA
I6	0.05 mA
I9	7 mA
V9	2 v
V10	0.5
Probe voltage	2.4 v
S/A	1.5 v

#### Results and Discussion

##### Ion Beam Thrusting

A summary of operating hours for both thruster systems is presented in Table 1. Table 2 presents representative values of detailed operating parameters of T/S-2 (thruster system 2). T/S-2 was operated 42 times in 1979-80 for a total of 606 hours at 85 mA beam and 58 hours at 200 mA beam. Solar array maximum power limits, as anticipated, prevented operation at 250 mA beam for more than a few seconds during each of four attempts. T/S-2 thrust data taken in 1980 agreed with that measured in 1979 and that measured in 1970, i.e., 10 mN at 85 mA beam and 22 mN at 200 mA beam. Experimental accuracy was ±3 percent for 85 mA beam and ±1.5 percent for 200 mA beam. These thrust values were measured from the resulting changes in spacecraft spin rate data, such as, shown in Fig. 4 for 1979-80. T/S-2 increased spin rate and T/S-1 decreased spin rate. Details of this type of thrust measurement may be found in the appendix of Ref. 2.

There has been no change in thruster performance over the 10-1/2 year period of space opera-

tion that included 4030 hours of operation (2744 with beam) and 261 restarts with T/S-2. An additional 110 hours of beam current was logged after the 4030-hour (next tank empty) point during distant-neutralizing tests described later. The main discharge of T/S-2 ran an additional 2635 hours after the 4030-hour point and is estimated to operate 2500 hours more before the main tank will be empty in March-April 1981.

T/S-1 beam operation was attempted ten times in 1979-80, but the H.V. short of 1970 remained. The description of its discharge operation is described below in the Plasma Mode and Durability testing sections.

#### Distant Neutralization

Reference 3 presented early data on distant neutralization, a term used to describe neutralization of T/S-2 beam by electrons emitted from the neutralizer of T/S-1, almost 1 meter away. Figure 5 (also in Ref. 3) shows a diagram of possible ion currents and plasma densities while in distant neutralization. One result of Ref. 3 that was difficult to explain, was that the neutralizer coupling voltage (between neutralizer and beam center) was lower in the distant coupling mode than for normal neutralization. Reference 6 suggested a model for coupling voltages that explained the relative ease (lower coupling voltage) of cross neutralization. This model used the thruster external magnetic fields and showed that neut-2 emission must cross magnetic lines to enter its beam plasma, while neut-1 emission can follow (without crossing) magnetic lines in a path reaching to the ion beam 1 meter away.

The fraction of emission coming from either neutralizer could be adjusted by varying a bias potential (V9, Fig. 2) to either neutralizer cathode. Figure 6 shows how this fraction changes with bias voltage in addition to corresponding changes in beam voltage and spacecraft voltage. The 83 mA beam data were from Ref. 3 while the 200 mA beam data are new in this paper.

The data of Fig. 6 show that for no bias voltage, most of the neutralizer emission came from the neutralizer near the ion beam. For 83 mA beam data, all emission could be put off from neut-2 by applying +34 volts bias to neut-2. Similarly, a bias of +6 volts on neut-1 (neut-2 at no bias) cut off all emission from neut-1. For 200 mA beam data, the neut-2 bias was set at its maximum value (+46 v.), but still about half the emission came from neut-2. The lack of complete cut off was probably due to the higher beam plasma voltage (acting like a natural anode) at 200 mA beam and a fixed bias limit. The spacecraft voltage and beam voltage shown on Fig. 6 react to neutralizer bias as expected from Ref. 2 or 5. (Space plasma potential is defined as zero.)

The increased difficulty of distant neutralization at 200 mA means that distant neutralization of a multiple thruster array, particularly at higher beam current, may not be as readily accomplished as first stated in Ref. 2. This is not to say that distant neutralization can not be accomplished on a multi array of 2 A beam current thrusters, merely that higher coupling voltages may be required.

#### No Local Neutralizer

The distant neutralization data taken in early 1979<sup>3</sup> was always modified by the fact that there was no way to operate an ion beam without having its local neutralizer also turned on. Simulated off conditions were achieved by applying positive bias to the local neutralizer cathode, but the on-board command sequences did not provide for separate disabling of the neutralizer. Therefore, a test plan was made to disable the neutralizer another way, that was, by operating it long enough to empty its mercury propellant tank. Then, even though commanded on, the neutralizer was incapable of significant emission because there was no mercury flow to establish a hollow cathode discharge. Under this condition the keeper electrode was at high (~250 v.) starting voltage and the tip heater was at maximum power. Thermionic emission at the maximum power temperature (1100° C) was less than 1 mA.

Neut-2 tank was emptied on day 122 (May 1) 1980 and distant neutralization tests were run in which (1) the main-1 and neut-1 discharges were turned on to neutralize the ion beam from T/S-2 (Fig. 7(a)), or (2) just neut-1 turned on (Fig. 7(b)). Later, when neut-1 propellant tank was empty, neutralization was accomplished from just the main-1 discharge (Fig. 7(c)). Figure 7 contains plots of ion beam plasma potential profiles taken with the movable hot wire probe of T/S-2. Voltages levels for the spacecraft and neut-1 are also shown and were determined by the probe for T/S-1 which was in a fixed position<sup>3</sup> midway between T/S-2 and T/S-1. Thruster operating conditions for Fig. 7 as well as Figs. 8 and 9 may be found in Table 3. (Each curve of the figures is given a number to key it to Table 3. Pass numbers in Table 3 key it to spacecraft control room data.)

Figure 7(a) results show three curves: (1) normal operation with local neutralization, (2) distant neutralizer with neut-2 biased off (1979), and (3) distant neutralization with neut-2 empty. As stated in the previous section, curve 2 shows a drop in beam plasma potential and coupling voltage when both neutralizer discharges were operating, although all emission seems to be coming from the distant neutralizer. Curve 3 shows a 25-volt increase in beam plasma potential with the local (neut-2) neutralizer empty. Interestingly curves 1 and 3 have about the same spacecraft potential, and the 34 volts positive bias of neut-2 (curve 2) lowered the spacecraft potential by 10 volts.

A hypothesis offered by Domitz<sup>2</sup> to explain the coupling voltages observed in Fig. 7(a) is the following: space charge neutralization of an ion beam may require only a small (~1 mA) number of electrons which become trapped in the positive well of the beam plasma. The only electrons that need to be added are equal to those lost from this well. Current neutralization may be achieved by other paths external and perhaps far downstream from the local neutralizer. (For example, neutralizer electrons could flow into the space plasma and other space plasma electrons could current neutralize the beam.)

Curve 2 with emission biased to "zero" may have emitted a net current of 3 mA and still have shown zero counts on the telemetry channel. The

neut-2 keeper potential was 28 volts above spacecraft potential and therefore a few volts above the "wing" plasma of curve 2. Hence electrons from the keeper discharge could have been easily drawn into the beam to provide space-charge neutralization, while neut-1 emission was providing the bulk of the current neutralization to space plasma. When the local neutralizer tank (neut-2) was empty and no keeper discharge was present, space charge electrons were drawn from further away and a higher coupling (beam plasma) potential resulted.

Figure 7(b) shows the effect of eliminating the plasma produced by the main-1 discharge. Without this additional plasma density, apparently useful to aid electron conduction, the beam plasma potential must increase to draw sufficient electrons to itself. Figure 7(b) shows a normal beam profile for reference together with two corresponding neut-2 curves, but with the main-1 discharge off. In curve 5, neut-2 empty, the beam plasma potential is not only high enough to exceed the design range of the probe, it has considerably broadened in width, and the spacecraft potential was lowered. All these trends were apparently caused by the need for neutralizing electrons and the relative impedance (no main-1 discharge plasma) to electron diffusion.

The data of Fig. 7(c) were taken later in 1980 after neut-1 tank was also empty. In this case the only source of net electron emission was the cathode of the main-1 discharge. For this case the shape of the beam plasma potential profile was about the same as for curve 5 (Fig. 7(b)), but the apparent coupling voltage was increased and the spacecraft voltage was driven to -70 v. The maximum beam plasma voltage is speculation because the probe design limits were again exceeded.

The operating conditions of both curve 3 and 5 (Fig. 7, neut-2 empty) were maintained for 2 days to obtain a thrust measurement with this type of neutralization. The result was a thrust of 9.9 mN ( $\pm 5$  percent) for curve 3 and 10.0 mN ( $\pm 3$  percent) for curve 5. Both these values were essentially the same as for normal neutralization-measured thrust<sup>2</sup> of 10.0 mN ( $\pm 3$  percent). Apparently no appreciable beam divergence was introduced by the distant neutralization, nor did the greater beam potential affect the thrust. This latter observation was not surprising as the maximum calculated value would be proportional to the square root of the respective net accelerating voltage, i.e. (3000-25) v. for curve 1, (3000-52) v. for curve 3, and (3000-85+) v. for curve 5.

The operating conditions of curve 6 could not be maintained for a long enough period to change the spacecraft spin rate and obtain a thrust measurement. This was due to the negative voltage magnitude of the spacecraft and a resulting large (>60 mA) amount of ions attracted to the accelerator grid of T/S-1. The >60 mA caused a built-in current overload protection circuit to trip and a cut back of the flow to the main-1 discharge. As the flow cutback, the discharge density and accelerator grid current were reduced below the trip point, thus permitting the flow to resume. This cyclic behavior was marginally stable, but never persisted for more than two hours. The change in spin rate in two hours was equivalent to the un-

certainty in reading the spin rate and no meaningful data resulted.

The most dramatic case of operation with no local neutralizer occurred when the conditions of Fig. 7(c) (curve 6) above were being attempted, and T/S-1 shut off completely due to a 2 minute-overload integration device incorporated into the system. Surprisingly, T/S-2 continued to operate at 85 mA beam current with no source of net electron emission. This condition lasted for 53 minutes and data was obtained from the on-board tape recorder. Eventually H. V. trips occurred to T/S-2 and the overload integrator device shut T/S-2 down. The above conditions were repeated 3 times, but the system never remained operating long enough to obtain a spin-rate thrust measurement. The conditions during this type of operation are listed in Table 3 as curve 7. No curve was plotted because the probe reading was always at its maximum value. This value indicated a spacecraft potential of  $< -106$  v. The actual value of spacecraft potential could have been any magnitude up to the positive H. V. (screen) of 3150 v. At such large negative spacecraft potentials the thrust should be severely reduced by beam turn around. Surprisingly, the accelerator grid, which was -1400 v with respect to the already negative spacecraft, did not attract enough ions to trip its overload value of 60 mA. The actual value was 33 mA as shown in Table 3. Apparently, the beam plasma shielded the accelerator grid and the remaining (85-33) mA of beam returned to other parts of the spacecraft where it was not sensed by telemetry.

The above case has not been fully modeled analytically, but space ions returning to the spacecraft were probably the order of 1 mA plus any sheath-enlargement factor. Change-exchange beam ions might have contributed an estimated 9 mA (Fig. 5) still leaving about 40 mA returning to other parts of the spacecraft or thruster ground shield. This flux of returning ions did not appear damage to the spacecraft which functioned normally during the beam turn around operation. T/S-2 itself might have become a casualty to beam turn around, because a day later, while operating T/S-2 (neutralized by neut-1 and main-1) a permanent H. V. thruster body short-to-ground developed. H. V. shorts are discussed in a later section, but note that this short was not the same as the 1970-type which was a screen-to-accel grid short.

#### Low-Mode Test.

Low mode is a main propellant control problem that can exist if the propellant flow should exceed a critical value. Flow rates higher than the critical value cause a reduction in beam current for an increase in flow; thus, a normal control loop will drive to maximum flow and the beam current will become lower and lower. The purpose of this section is not to describe how to avoid low mode, but rather to publish flight data taken of beam plasma potential while a thruster was in low mode. T/S-2 went into low mode during a test in which H. V. was turned on with no preheat and before the main discharge was lighted. Excess propellant condensed in flow passages prior to lighting. Once lighted, heat from the discharge evaporated the condensed mercury and drove the flow rate past the critical flow point. (Normal

preheating for 5 minutes prevented this condensation.) The thruster remained in low mode for several hours before being commanded off. The data of Fig. 8 and Table 3 (curves 8-10) were taken during this time.

Figure 8 shows the beam plasma potential profile for a 10 mA beam at 3140 v. net accelerating voltage, and for two profiles in which neut-2 was biased +40 v. and -34 v. Also shown are spacecraft potential level (measured by probe 1) and the respective neut-2 potential. Note all potentials were relative to space plasma which was assumed zero. The profile for no neut-2 bias was much flatter than for a normal beam. The reason may be an abundance of charge exchange plasma, caused by the high propellant flow rate, lowering the impedance of the neutralizer plasma bridge, or/and a lower coupling voltages due to the lower amount of neutralizer electrons needed at the low beam current. Biasing of neut-2 accentuated the profile as shown in Fig. 8.

#### H. V. Shorts

The table below summarizes H. V. shorts that have occurred on SERT II flight thrusters. From telemetry analysis of the V5 and V6 supplies it was possible to conclude that all shorts except No. 4 on T/S-2 were between V5 and V6, i.e., the screen and accelerator grid. Also concluded was that the value of the short was below 10 K ohms.

Short no.	T/S-1		T/S-2	
	Beam, hr	Year	Beam, hr	Year
1	2385	1970	2011	1970
2	3781	1970	2561	1979
3			2626	1979
4			2744*	1980

\*This short between 2V5 and thruster (spacecraft) ground, all other shorts between V5 and V6.

Short 1, T/S-1, was removed by a single shut down and normal preheat period. Short 2 still exists in T/S-1 after 300 thermal recycles and 20 attempts to sustain high voltage. T/S-2, short 1, occurred in 1970 and was not cleared until 1974 following a spacecraft spin manuever which placed the thruster in a small artificial gravity of about 0.01 "g". T/S-2, short 2, occurred during a test in which high voltage was applied with no discharge to measure grid insulator leakage. No leakage was found, but a H. V. grid short developed, possibly from a higher voltage stress on the grids. The V5 and V6 supplies produced 10-percent higher voltages without the normal beam load and these voltages might have bent a grid web fragment that was weakened in the prior 550 hours of beam operation. Short 2 was cleared by a cold restart application of H. V. after several hot restarts failed T/S-2, short 3, occurred during another test of H. V. application with no discharge. In this case the main discharge lighted, produced a beam current for 2 to 15 seconds, and then T/S-2 developed a V5-V6 short. Several hot and cold restarts of high voltage were tried before the short finally cleared following a long heated period. The last short of T/S-2 was a short of <10 K ohms between 2V5 and thruster ground. This

short occurred after 1-1/2 hours steady state operation at 85 mA beam with neutralization from neut-1/main-1, and also one day after operating T/S-2 for 53 minutes with no neutralizer source. Short 4 still remains despite sixteen thermal recycling efforts to clear it.

The V5-V6 shorts were believed caused by neutralizer discharge ions striking the accel grid, causing erosion and web fragments to be produced. The web fragments would be electrostatically drawn to and short to the screen grid. The V5-ground short location was not as apparent. The most probable area was a plate attached to the thruster ground screen, underneath the neutralizer cathode. This plate was in close proximity (~3 mm) to a surface of the thruster body (V5 potential).

#### Plasma Beam Thrust

Plasma beam thrust is a new SERT II thrust operating mode (utilizing only the main discharge chamber plasma) that was discovered by chance in late 1979. At that time T/S-1 main discharge was turned on and allowed to run continuous for endurance testing. After several days, it was noticed that the spacecraft spin rate was changing at a rate greater than normal! T/S-1 was producing thrust, about 0.8 mN, with no (V5 and V6 turned off, see Fig. 2) voltages on the accelerator grids. Furthermore, no ion beam was indicated by telemetry measuring circuits.

What apparently happened was that the main discharge (V4) produced a mercury plasma at the level of the V4 voltage, 40 v. This plasma diffused through the accelerator grids, carrying an equal number of electrons and ions. Once by the grids the ions were accelerated through a 40 v. sheath, producing a thrust beam. Electrons somehow were either carried along by the ion space charge or diffused into space plasma. This type of plasma beam acceleration has been studied earlier<sup>7</sup>. In this study<sup>7</sup>, however, the arc source, which was similar to an electron bombardment discharge chamber, had no grids to impede the acceleration of plasma or ions from the discharge chamber.

In any event, T/S-1 was producing thrust and the main discharge supply was the only supply that could give energy to produce a thrust beam. Subsequently, other tests were run at lower discharge voltage, which dropped the thrust level, and with the other thruster system, which produced about the same level of thrust. The thrust measured for 16 plasma beam thrust tests on SERT II is shown in Table 4. Also in Table 4 are thruster operating conditions, estimated flow rate (from ground tests in 1970<sup>8</sup> and 1980<sup>9</sup>), estimated floating levels of the V5 and V6 supplies,<sup>9</sup> and a calculated plasma beam ion current. The beam calculation assumed a one-dimensional ion beam of net energy as listed in Table 4. The actual plasma beam has some degree of divergence, which if incorporated in the calculated ion current, would increase the ion current (perhaps by 20 percent). A qualitative idea of the divergence may be seen on p. 37 of Ref. 10, or in Fig. 9 of this paper. The nominal performance of the thruster operating in the plasma thrust mode is listed below:

Thrust	0.8 mN
I <sub>sp</sub> , corrected	300 sec
Power (discharge only)	80 W
Flow rate	1 gm/hr
Power/thrust	100 W/mN

The plasma potential of the plasma beam for T/S-2 is shown in Figs. 9(a) and (b) for two cases of neutralizer keeper discharge on and off, respectively. Figure 9(a) curve 11 shows a broad, but relatively flat potential profile as compared to the ion beam profiles of Fig. 7. When the neut-2 was biased to -44 v., the potential edge of the plasma beam becomes better defined and a negative well was formed on either side. Biasing of the neutralizer exhibited potential control of the spacecraft as if the normal ion beam were operating. The design of the bias supply<sup>3</sup> did not permit positive bias while in the plasma beam mode, so negative spacecraft voltages were not demonstrated.

Figure 9(b) shows plasma potential profiles after neut-2 tank became empty and no neutralizer keeper discharge was on. The center of the plasma beam becomes highly positive (curve 13) and the plasma beam potential profile is broadened over that shown in Fig. 9(a) (neut. operating). The corresponding thrust produced dropped from 0.8 to 0.5 mN and the spacecraft potential dropped from -10 to -20 v. By turning on neut-1, the positive plasma beam potential was reduced, as shown by curve 14, and the spacecraft potential was raised. By applying -46 v. bias to neut-1, the positive plasma beam potential was further reduced and the spacecraft potential raised.

The identification and measurement of the plasma beam thrust should be an aide to designers of future electric propulsion spacecraft. For, example (1) an ion thruster in the plasma beam mode might be used for spacecraft attitude or potential control without the need for a high-power thruster to be on; (2) an ion thruster in a discharge warm-up mode will produce thrust and might require adjustment to account for disturbing torques; and (3) if an ion thruster has suffered a H. V. failure, it could still produce useful thrust in the plasma beam mode.

#### Durability Testing

##### Main Cathodes

The main cathode of T/S-1 operated for 7837 hours and 240 restarts before the main propellant tank became empty. During this period there was no noticeable change in cathode performance as evidenced by no trend in main discharge nor keeper discharge. Cathode starting times varied from 0.3 to 9.5 minutes depending on initial system temperature. (Design specification was to light in 90 minutes of preheat.) Furthermore, as seen in Table 5, no change occurred in cathode tip heater resistance over the operating period. Main cathode of T/S-2 is still operating at the time of this writing (Dec. 1, 1980), and has accumulated 6542 hours of running with 300 restarts demonstrated. As for T/S-1 main cathode, this main cathode was operated without detectable change in its main and keeper discharges, or in its tip heater resistance (Table 5). It has started very reliably, particularly in the last two years. (During 1974-76, while the spacecraft was in deep

shadow periods, some what longer starting times (10 to 41 min.) were required to warm up to starting conditions.)

The successful operation of the main discharge chambers for near 8000 hours in space has bearing on the concerns evidenced in Ref. 11. Reference 11 addressed sputtering in mercury bombardment thrusters and the effect of reduced sputtering resulting from adsorbed vacuum tank gases. Reference 11 presented sputtering data over a range of vacuum tank pressures, including operation down to the 10<sup>-7</sup> torr range which is difficult to obtain. The authors of this paper believe that Ref. 11 was correct in assuming that extrapolating down from the high 10<sup>-7</sup> torr range was sufficient to indicate erosion rates to be expected in space, which is 3 orders of magnitude or lower, pressure. The SERT II data, however, is proof that no dramatic change in discharge chamber erosion will occur in the ultra-low vacuum of space.

##### Neutralizer Cathodes

The performance of the neutralizer cathodes equals that of the main cathodes, i.e., there was no noticeable change in discharge characteristics, restarting was consistent, and tip heater resistance was unchanged over the full test time. The table below summarizes the totals for the neutralizer cathodes. Reference 12 correlated restart time to initial system temperature which was the main variable affecting start time.

##### Neutralizer cathodes

System	Total, hr	Restarts	Restart time, min
T/S-1	4919	222	3 to 7
T/S-2	3870	261	3 to 7

##### Main Keeper Insulator

Figure 10 shows some of the construction details of the main cathode keeper electrode design. This design has proven satisfactory for 7837-hours of operation and 300 restarts over a 10-year period in space. Features of the design included a solid tantalum electrode and a swaged insulator support tube. The electrode was made of a refractory metal to resist melting. The normal operating discharge heat load was only several watts, but during starting transition from high voltage, the heat load may be 35 watts. The starting transition, although usually brief (<1 min.), may last longer if the mercury flow rate does not increase promptly to its full value. The swaged insulator was undercut to improve resistance to surface contamination, and a line-of-sight baffle was located as shown in Fig. 10 to reduce the flux of sputtered metal on the exposed end insulator.

The resistance of this design to contamination can be inferred by the data of Figs. 10(a) and (b), for thruster systems 1 and 2, respectively. These data give the change in keeper voltage with operating time. As there was no telemetry channel to measure main keeper current, any insulator leakage current must be inferred by changes in the keeper voltage and a known I-V curve of the

keeper power supply. The data of Fig. 10 were taken during preheat conditions when voltage was applied, but no mercury flow was present to start a discharge. The data show a slight decrease in keeper voltage with time. This change in keeper voltage resulted in no apparent change in starting or operation of the main cathode. The uncertainty range of the data is due to  $\pm 1/2$  count difference in measured keeper voltage and solar array input voltage. Leakage currents, estimated from I-V load curves, are shown on Fig. 10 to give the reader an idea of the magnitude of this current. (The "roll-off" or I-V slope of each supply was unique and accounted for the variance between Figs. 10(a) and (b) in the values of leakage current shown.)

The conclusions from Fig. 10 were: (1) no problem resulted from the small amount of leakage current that occurred, (2) this current increased with time, probably due to surface build up at the exposed end of the swaged insulator, (3) future insulator designs should be at least equivalent to that used, and (4) the roll-off design of the keeper voltage supply should provide adequate starting voltage for end-of-life leakage currents as high as 20 mA.

#### Neutralizer Keeper Insulator

Figure 11 shows some of the construction detail of the neutralizer keeper electrode design. The sketch is to scale with the  $Al_2O_3$  insulator being 0.6 cm across. Insulator shielding design included the keeper electrode itself and a spacer washer between the keeper and  $Al_2O_3$  block to minimize contact between the two. (In retrospect, a spacer washer probably should have been used under the screw head, also.) The electrode was tantalum to avoid melting for the same reasons noted above for the main cathode keeper.

Figure 11 also shows plots of neutralizer keeper leakage current with total operating hours for both flight thruster systems. The current was directly measured by telemetry before the discharge begins. The increase of this current with time probably was caused by a build-up of condensed sputtered metal on the  $Al_2O_3$  insulator surfaces. This build-up may have been sputtered accelerator grid material (molybdenum). The curves are broken into sections of normal beam operation (dashed curve), no beam with neutralizer and main discharges lighted (dotted curve), and finally a period of only main discharge lighted (solid curve). Build up seemingly occurs during beam on periods, with a greater build up for thruster system 1 which had the longer beam on period. The no beam period was a time in which the leakage current apparently decreased. The authors formulate no reason for this decrease, but point out that this no-beam period included 9 calendar years for thruster system 1. The 9-year period for thruster system 2 occurred between the 250 mA and 85 mA beam operating periods. The final period was one of no accelerator grid erosion and no change in leakage current. Also, during this period, the leakage current could be measured more accurately because no neutralizer discharge occurs.

Figure 12 shows the semiconducting nature of the build-up film on the insulator. The data for

Fig. 12 was taken after the neutralizer Hg tanks were empty and a longer preheating time was possible to get leakage resistance values at thermal equilibrium. With Hg in the tank, the neutralizer discharge lighted in 3 to 7 minutes. Once lighted, the telemetry read the sum of leakage plus discharge current, with the latter being much greater (5 to 10 times). The arrows on the data of Fig. 11 indicate leakage current values that the authors believe would have been reached, had the discharge not lighted. The plotted circles are values of leakage current reached just before discharge lighting.

The conclusions reached from the data presented in Figs. 11 and 12 were: (1) the neutralizer keeper insulator shielding design was adequate, but not as good as that for the main keeper; (2) the insulator surface build-up resulted in leakage currents of 10 to 29 mA during neutralizer cathode lighting attempts, and a resulting fall-off of keeper starting voltages from 420 v. to a range of 250 to 300 v; (3) even at the reduced keeper starting voltage, however, the neutralizer continued to relight upon command, (4) more attention should be given to future insulator shielding designs to prevent sputtered metal from reaching critical insulator areas; and (5) the design keeper voltage "roll-off" should provide for a leakage current margin of 10 to 20 mA at the minimum starting keeper voltage.

#### H. V. Grid Insulators

Tests were made on T/S-2 in late 1979 in which H. V. was applied to the grids before the thruster discharges had lighted. This was done both for a cool (60° C neut-2 tank) thruster and a warm (at normal operating temperature, 112° C neut-2 tank, 88° C ground screen) thruster. In both cases, there was no measurable leakage in either I5 (<1.5 mA) or I6 (<0.1 mA) for V5 of 4020 v. and V6 of -1650 v. This result of no measurable insulator degradation agrees with results from thruster life tests in vacuum chambers and confirms the insulator design. The insulators were  $Al_2O_3$  balls with double cup, line-of-sight, shields. The grid insulators of T/S-1, of course, could not be tested because of the H. V. grid short that was present.

#### Neutralizer Propellant Tanks

The neutralizer propellant tanks of each thruster system were operated until they became empty of mercury. This occurred on day 203, 1980 for thruster system 1 and day 122, 1980 for thruster system 2. The purpose of this section is to present detailed performance data of the neutralizer propellant tanks and compare this performance with design predictions.

A schematic cross section of a neutralizer tank is shown in Fig. 13. The tank consisted of two nearly equal volumes. One contain liquid mercury and the other contained a pressurizing gas (80 percent  $N_2$ , 20 percent Kr) (Krypton gas was added as a tracer gas for leak detection ground tests.) The two volumes were separated by a butyl rubber bladder which terminated in an "O-ring" shape. This "O-ring" formed a seal between the two halves of the tank. A pressure transducer was mounted on the gas volume and a temperature sensor



was located externally on the essentially isothermal tank.

As mercury flows out of the tank, the gas volume increased and the pressure decreased. A plot of this pressure decrease with operating time is shown in Figs. 14(a) and (b) for neutralizer tanks 1 and 2, respectively. (The pressure values were at discrete levels due to the telemetry count system used.) The use of the pressure change with time and the ideal gas law, permitted a calculation of the change in gas volume. The gas volume change was equal to the change of the mercury volume, and the mercury flow rate thus could be calculated. A second way to calculate the mercury flow rate was to integrate all flow periods after the tank is empty and divide into the total mercury loaded. Table 6 gives major flow periods for each neutralizer tank and respective data about flow rates. The flow rates based on the integrated total flow are in good agreement with ground based flow rate taken with "flow tubes" before launch. Flows rates earlier estimated, based on the ideal gas law, were 10 to 20 percent higher than the integrated total flow rates. An error in the ideal gas law calculations was caused by not accounting for diffusion or leakage loss of pressurizing gas through the rubber bladder.

A complete analysis of gas diffusion was somewhat involved, but will be presented here because of possible impact on future propellant system design. There were two gas diffusion paths of interest. One was straight through the bladder from the gas side to the mercury side. This path was of no importance in the SERT II design, but may be significant in other designs. Any gas diffusing to the mercury side will become trapped, setting up a near equal back pressure and reducing the net diffusion rate. The only way for that gas to escape would be past the "O-ring" seal or past the natural mercury seal formed by liquid mercury in the tube between the tank and the vaporizer. Neither of these escape paths were probable in the SERT II design. Future designs, however, should confirm that a natural mercury seal exists, that is, there is no surface roughness nor grooves on the tube inside wall that would allow gas to slip past the liquid seal. The second diffusion path of interest was the following: gas entered the rubber bladder, traveled sideways in the rubber until it reached the "O-ring." It continued through the rubber of the "O-ring" and escaped past the unsealed outer joint between tank-half flanges. Whereas this path was very tortuous, it did constitute the major path of pressurizing gas loss. The rate of pressurizing gas lost during storage periods of 1971 to 1978 was able to be measured (see Fig. 14(a) or (b)). The measured loss rates agreed within 20-percent with the calculated diffusion loss rate through the "O-ring" material.

During the storage periods the tank temperature was cooler (35° to 60° C) than when the thruster was operating (98° to 105° C). Literature values of butyl rubber diffusion rates<sup>13</sup> were used to extrapolate diffusion low rates during thruster operation at high temperatures. The diffusion rate was 25 times greater at 105° C than at 35° C. The higher temperature diffusion rate value was used to correct the pressure decrease in the ideal gas law flow calculations.

When this was done, the flow rates thus calculated were within experimental error of those flow rates calculated from integrated total flow data.

After the mercury was empty (4991 hr T/S-1 and 3870 hr T/S-2) the gas reservoir pressure dropped rapidly. This drop in pressure was caused by gas diffusion directly through the butyl rubber bladder. The gas that diffused across the bladder was now more free to flow through the empty mercury propellant line, through the porous tungsten vaporizer plug and out through the neutralizer cathode orifice to space. The gas pressure decay curve was used to calculate a gas flow rate. This flow rate agreed with a flow rate calculated from butyl rubber diffusion rates, rubber thickness and surface area. The agreement was further supported by diffusion flow at two temperature levels giving two points of comparison. The two rates can be seen on Fig. 14(b): a low rate (tank cold) from 4120 to 6300 hours, and a high rate (tank hot) from 6300 to 9200 hours.

Conclusions based on neutralizer tank pressure data were:

(1) Neutralizer flow rate performance in space was the same as for ground vacuum chamber thruster operation over all conditions tested.

(2) The design of a butyl-rubber bladder blow-down tank was validated for a 10-year period with the following constraints; thermally design the tank to cool temperatures (20° C) where gas diffusion through the bladder is low enough for mission life, or depend on the liquid mercury to seal or trap the diffused gas.

(3) Under normal flow operation (some mercury remaining in tank) the loss of pressurizing gas was negligible. The total of any leakage plus diffusion measured over an 8-year storage period was only  $1.7 \times 10^{-4}$  cm<sup>3</sup>/hr (STP). A small excess (10 to 15 percent) of pressurizing gas could provide for this loss, even over a 10 year system life.

(4) There were no known materials compatibility problems. The neutralizer tank provided pressurized liquid mercury to the vaporizer for the full life of the tank capacity. There were no known leaks of mercury and the tank capacity was exhausted when anticipated. The leakage of pressurizing gas was less than specified for typical gas-tight construction and had no impact on the flow-life of the system.

#### Main Propellant Tanks

The design of the main propellant tank followed the same philosophies as for the neutralizer propellant tank, but the main tank was constructed in a larger size to hold 14 kg of mercury. Because the main tank was at high voltage, no pressure transducer was used to measure change of pressurizing gas with time. Hence, there was no way to estimate flow rate as the mission progressed. Once the main tank is empty, however, the estimated flow rates could be integrated and compared with the total used to give a measure of confirmation of the actual flow rates.

The main propellant tank of T/S-1 became empty on December 1, 1980. Table 7 summarizes the

operating hours and estimated flows<sup>8</sup> for main tank-1. The estimated integrated total flow was 13,830 gm which was only 1.6-percent less than the useful mercury, 14,050 gm, loaded into the tank (50 gm of additional mercury was loaded into the line between the tank and vaporizer and was considered to be unavailable for use.) The 1.6-percent difference probably resulted from the accuracy of the estimated flows while T/S-1 was in discharge operation. Discharge only operation flow rates accuracy was not emphasized in pre-launch tests because the original mission plan was to run but a few hours at discharge only, with the bulk of operation to be at full beam current. Other uncertainties existed in the estimated "end-effects" of restarting, stopping and short clearing tests. All of these "end-effects," however, amount to a small total, and estimation inaccuracies were of no importance. Main tank-2, when run to exhaustion (est. time, March-April 1981), will give more information on main flow rates.

The authors believe that the 1.6-percent difference of main tank-1 constitutes excellent confirmation that a mercury bombardment thruster operated at essentially the same propellant utilization in space as measured in laboratory vacuum tanks.

#### Vaporizers

Because the vaporizers caused absolutely no trouble, their performance tended to be overlooked. Vaporizers were made of porous tungsten (2.4 micron bore diam, 70 and 76 percent dense) electron-beam welded into tantalum housings. Vaporizer design and flow information is documented elsewhere<sup>14</sup>. The SERT II flight vaporizers with stood flight qualification and launch vibration, 11 years in space, 5000 to 8000 hours of operation, and 300 restart cycles, all without failure. The dynamic head (distance from tank to vaporizer) was kept small by design, so that no valve was necessary to withstand launch vibration pressures that might force liquid mercury through vaporizer pores. The vaporizer operating power with time (see tables 2 or 5) was nearly constant, and the small differences that were measured were probably a result of a varying thermal (sun-angle) environment more than anything else.

#### Concluding Remarks

As the greatly-extended life of the SERT II spacecraft is nearing completion, it is time to reflect on the accomplishments of this electric propulsion spacecraft. First, the 11-year useful life of a spacecraft designed for 18-months, is a tribute to the design and qualification team of Lewis Research Center employees and subcontractors that built the spacecraft in 1969. Next, the prime experiment, the ion thrusters, proved themselves with remarkably durable and high quality performance while accomplishing one mission objective after another. It is true that the main objective, 6-months operating time in space from one thruster system, was not reached in 1970; but one thruster did run for 5 months before a H. V. short stopped its beam. All other parts of the thruster system functioned as designed or better, until at last the propellant tanks became empty and testing was no longer possible.

Extended mission objectives accomplished were: (1) clearing the H. V. short from T/S-2 and reestablishment of normal thruster operation in 1979 and 1980 after 10 years space storage, (2) successfully demonstrating 300 restarts without difficulty, (3) operating discharge chambers for nearly 8000 hours (11 months) in-space, (4) documenting a new form of plasma beam thrust from a discharge chamber, (5) acquiring in space information on low-energy plasma interactions between thruster systems and between thrusters and spacecraft, and (6) the demonstration of "distant neutralization" of an ion beam from a neutralizer one meter away.

More than anything else gained, was the confidence that mercury bombardment ion thruster systems can be built and operated in space on a routine basis with the same lifetime and performance as measured in ground testing.

#### References

1. Kerlake, W. R., Goldman, R. G., and Neiberding, W. C., "SERT II: Mission, Thruster, Performance and In-Flight Thrust Measurements," *Journal of Spacecraft and Rockets*, Vol. 8, Mar. 1971, pp. 213-224.
2. Kerlake, W. R. and Ignaczak, L. R., "SERT II 1979 Extended Flight Thruster System Performance," AIAA Paper 79-2063, Oct. 1979.
3. Kerlake, W. R. and Domitz, S., "Neutralization Tests on the SERT II Spacecraft," AIAA Paper 79-2064, Oct. 1979.
4. Ignaczak, L. R., Stevens, N. J. and LeRoy, B. E., "Performance of the SERT II Spacecraft after 4-1/2 Years in Space," NASA TM X-71632, 1974.
5. Jones, S. G., Staskus, J. V., and Byers, D. C., "Preliminary Results of SERT II Spacecraft Potential Measurements Using Hot-Wire Emissive Probes," AIAA Paper 70-1127, Sep. 1970; also NASA TM X-52856, 1970.
6. Kaufman, H. R., "Plasma Physics Analysis of SERT II Operation," Colorado State Univ., Fort Collins, CO, Jan. 1980. (NASA CR-159814).
7. Burkhart, J. A., "Initial Performance Data on a Low-Power MPD Arc Thruster with a Downstream Cathode," AIAA Paper 70-1084, Aug. 1970.
8. Byers, D. C. and Staggs, J. F., "SERT II Flight-Type Thruster System Performance," AIAA Paper 69-235, Mar. 1969.
9. Wilbur, P. J. "Ion and Advanced Electric Thruster Research," Colorado State Univ., Fort Collins, CO, 1981. (NASA CR-165253).
10. Wilbur, P. J., "Physical Phenomena in Mercury Ion Thrusters," Colorado State Univ., Fort Collins, CO, Dec. 1979. (NASA CR-159784).
11. Manteniaks, M. A. and Rawlin, V. K., "Sputtering in Mercury Ion Thrusters," AIAA Paper 79-2061, Oct. 1979.
12. Kerlake, W. R. and Finke, R. C., "SERT II Hollow Cathode Multiple Restarts in Space," AIAA Paper 73-1136, Oct. 1973.
13. Rittenhouse, J. B. and Singletary, J. B., *Space Materials Handbook*, 3rd Edition, NASA SP-3051, 1969, p. 313.
14. Kerlake, W. R., "Design and Test Porous-Tungsten Mercury Vaporizers," AIAA Paper 72-484, Apr. 1972; also NASA TN D-6782, 1972.

TABLE 1. - SUMMARY OF OPERATING HOURS  
FOR SERT II THRUSTERS

Year(s)	Thruster 1, hr				
	250 mA beam	200 mA beam	85 mA beam	Discharge only	
				w/neut	w/o neut
1969	63	8	8	4	-----
1970	3794	3	3	33	-----
1971-72	-----	-----	-----	42	-----
1973-78	-----	-----	-----	36	-----
1979-80	-----	-----	-----	<sup>a</sup> 1003	<sup>b</sup> 2940
Total beam	3879				
Total neut.				4997	
Total discharge				<sup>b</sup> 7937	

Year(s)	Thruster 2, hr				
	250 mA beam	200 mA beam	85 mA beam	Discharge only	
				w/neut	w/o neut
1969	43	8	8	4	-----
1970	2017	2	2	8	-----
1971-72	-----	-----	-----	20	-----
1973-78	0	0	1	249	-----
1979-80	0.01	58	606	<sup>a</sup> 1005	<sup>c</sup> 2635
Total beam	2744				
Total neut.				4030	
Total discharge				<sup>c</sup> 6665	

<sup>a</sup>Neutralizer Hg tank empty at end of test hours.  
<sup>b</sup>Main Hg tank empty, Dec. 1, 1980 at end of test hours.  
<sup>c</sup>As of Dec. 8, 1980; still operating (est. empty in 2500 more hr).

TABLE 2. - PERFORMANCE OF FLIGHT THRUSTER 2

	Preheat										Propellant, no beam									
	1970 2/11 10	1973 6/1 80	1974 10/7 213	1975 12/4 215	1976 4/22 216	1977 11/29 218	1979 1/22 219	1979 7/5 230	1980 2/29 251	1980 12/1 300	1970 2/11 10	1973 6/14 86	1974 8/23 195	1975 12/4 215	1976 9/22 216	1977 11/29 218	1979 1/22 219	1979 9/10 234	1980 12/1 300	
Main vaporizer heater	0	0	0	0	0	0	0	0	0	0	91.63 91.41	al.49 al.32	1.85 1.70	1.85 1.80	(f)	1.75 1.65	1.63 1.58	1.70 1.67	1.56 1.58	
Main cathode heater	16.0	15.6	15.6	15.6	15.0	15.4	14.4	15.2	15.2	8.7	9.5	9.1	9.1	9.1	6.4	5.9	5.9	5.6		
Main discharge	>50	>50	>50	>50	>50	>50	>50	>50	>50	39.9	39.7	40.4	40.4	40.4	40.7	39.4	35.4	35.4		
Beam voltage	0	0	0	0	0	0	0	0	0	0	0	0	0	0	0	0	0	0		
Beam current	0	0	0	0	0	0	0	0	0	0	0	0	0	0	0	0	0	0		
Accelerator grid	0	0	0	0	0	0	0	0	0	0	0	0	0	0	0	0	0	0		
Neutralizer heater	97.7	8.8	8.6	10.4	8.2	8.4	7.9	8.1	10.3	97.7	al.04	8.4	8.8	8.8	8.4	7.5	8.4	10.3		
Neutralizer keeper	28.5	27.8	27.8	28.5	28.5	28.5	28.1	28.1	12.54	28.5	al.23	28.5	28.5	28.5	28.5	28.1	28.8	1254		
Spacecraft voltage	0	0	0	0	0	0	0	0	0	0	0	0	0	0	0	0	0	0		
Neutralizer emission	-6	(f)	-3	(f)	(f)	(f)	-7	-5	-14	-9	(f)	-4	(f)	(f)	(f)	(f)	-5	-5		
Main cathode keeper	0	0	0	0	0	0	0	0	0	0	0	0	0	0	0	0	0	0		
Solar array voltage	70	62	65	77	63	67	61	61	59	38	12.3 b0.280	9.9 b0.273	10.8 b0.273	11.3 b0.271	61	65	61	61	57	

	85 mA beam										200 mA beam										Telemetry un-certainty (rss)
	1970 2/11 10	1974 9/10 198	1975 12/4 215	1976 9/22 216	1977 11/29 218	1979 1/22 219	1979 7/5 230	1979 9/10 234	1980 2/29 251	1980 12/1 300	1970 2/11 10	1974 9/11 200	1974 8/23 195	1975 12/4 215	1976 9/22 216	1977 11/29 218	1979 1/22 219	1979 9/10 234	1980 12/1 300		
Main vaporizer heater	91.63 91.51	1.70 1.77	1.70 1.70	0.19 0.09	al.67 al.97	1.70 1.67	1.70 1.67	1.63 1.67	1.63 1.67	1.63 1.67	1.63 1.67	1.70 1.70	1.85 1.95	1.85 1.85	1.78 1.85	1.63 1.58	1.70 1.67	1.56 1.58			
Main cathode heater	7.9	8.7	8.7	(f)	(f)	8.2	8.2	5.2	5.2	5.2	8.3	8.7	8.2	8.2	5.6	5.6	5.6	5.6			
Main discharge	1.54	1.57	1.57	1.61	1.61	1.57	1.55	1.55	1.55	1.55	1.57	1.57	1.57	1.57	1.60	1.60	1.60	1.60			
Beam voltage	42.2	42.4	42.4	39.8	42.3	38.3	39.7	39.7	39.7	39.7	41.5	41.4	41.5	41.4	38.4	40.2	40.2	40.2			
Beam current	0.7	0.6	0.56	al.47	(f)	0.60	0.60	0.62	0.62	0.62	1.1	1.1	1.1	1.2	1.2	1.2	1.2	1.2			
Accelerator grid	0.88	0.83	0.83	0.172	0.119	0.303	0.296	0.083	0.083	0.083	0.203	0.198	0.198	0.199	0.200	0.200	0.200	0.200			
Neutralizer heater	96.6	8.1	7.7	7.1	7.1	7.5	7.5	10.1	10.1	96.4	7.5	7.5	7.0	6.7	6.6	6.6	6.6	6.6			
Neutralizer keeper	27.8	27.8	27.8	28.5	29.2	28.5	28.1	28.1	28.1	28.1	29.0	27.8	27.8	27.8	28.1	28.1	28.1	28.1			
Spacecraft voltage	0	0	0	0	0	0	0	0	0	0	0	0	0	0	0	0	0	0			
Neutralizer emission	-17	(f)	(f)	(f)	(f)	-9	-9	e-101	e-101	(f)	(f)	(f)	(f)	(f)	(f)	(f)	(f)	(f)			
Main cathode keeper	20.4	20.0	20.0	13.8	15.7	18.9	19.8	17.6	17.6	13.9	13.1	13.1	13.1	12.9	13.1	13.1	13.1	13.1			
Solar array voltage	68	59	56	h50	h49	59	59	57	57	63	52	52	h50	53	52	52	52	52			

a. Value changing in response to control signal.  
 b. 110 value estimated from V10 value and power supply response characteristic curve.  
 c. Values due to different set points.  
 d. Difference in values due to different solar array voltages input to power processor.  
 e. Neutralized by main discharge, thruster 1.  
 f. Data unavailable.  
 g. Heater power lower due to higher thermal background.  
 h. Value estimated from V5.  
 i. High neutralizer tank depleted.

TABLE 3. - DATA FOR FIGURES 7, 8 AND 9

Pass	Curve	215 mA	2V5 v.	216 mA	2V6 v.	218 mA	2V8 v.	219 mA	2V9 v.	116 mA	118 mA	119 mA	1V9 v.	Main-2	Main-2	Main-1	Main-1
R2	1	83	3010	1.1	-1500	172	28	80	0	(a)	(a)	(a)	(a)	On	On	Off	Off
R5	2	83	3010	1.1	1.7	172	28	0	+34	0.0	160	73	0	On	On	On	On
53	3	85	3010	1.1	1.7	43	244	0	6	2.1	160	83	0	On	On	Off	Off
R11	4	83	3010	1.1	1.7	172	28	0	0	1.5	160	80	0	Empty	Empty	Off	Off
54	5	83	3010	1.1	1.7	43	244	0	0	0.0	168	80	0	Empty	Empty	Off	Off
59	6	3150	33	1.7	-1400	27	291	0	0	>60	51	235	0	Empty	Empty	On	On
61	7	3150	33	1.7	-1400	27	282	0	0	(a)	(a)	(a)	(a)	Empty	Empty	Off	Off
44	8	10	3150	3.9	-1450	179	28	3	+40	(a)	(a)	(a)	(a)	On	On	Off	Off
44	9	10	3150	4.1	-1450	179	28	3	0	(a)	(a)	(a)	(a)	On	On	Off	Off
44	10	10	3150	5.6	-1450	179	28	3	-34	(a)	(a)	(a)	(a)	On	On	Off	Off
214 Plasma thrust mode																	
27	11	1.90	40	0.0	+2	172	29	0	0	(a)	(a)	(a)	(a)	On	On	Off	Off
27	12	1.90	40	0.0	+10	172	27	250	-44	(a)	(a)	(a)	(a)	On	On	Off	Off
51	13	1.90	40	22	+48	51	235	0	0	(a)	(a)	(a)	(a)	On	On	Off	Off
52	14	1.90	40	3.0	+23	62	216	0	0	(a)	(a)	(a)	(a)	Empty	Empty	On	On
52	15	1.90	40	0.0	+2	66	216	0	0	0.0	160	29	150	0	0	On	On
63	16	1.80	34	0.0	+2	43	253	0	0	0.0	66	207	0	0	0	Empty	Empty

aThrustor system 1 commanded off.

TABLE 4. - PLASMA MODE THRUST MEASUREMENTS

Year	Thrustor	Pitch gimbals angle, deg	Days of data 1979/80 day-to-day	Meas. arpm	Natural decay, arpm	Net arpm due to thrust	Thrust calc. from net arpm, mN	Probe voltages			Main anode keeper		Accelerator grid	Thrustor body VS	Thrustor short	Hg flow (est), mA	Solar array Vin, V	Net accel voltage V4-V5, v.	Calc. ion current, mA
								No. 1, v.	No. 2, end of travel, v.	No. 14, amp	V4, v	V8, v							
1979	1	-11.1	275.76-278.82	-0.107	-0.0046	-0.102	0.77±0.07	4	2	2.15	39.7	160	29	0.0	a+2.6	135	61	38	61
			288.61-292.73	-1.48	-0.0053	-1.43	.80±0.06	5	4	2.15	39.7	160	29	0.0	a+2.6	135	59	37	65
			302.69-306.80	-1.20	-0.0045	-1.14	.65±0.05	5	2	2.02	34.7	164	29	0.0	a+1.7	184	28	28	60
			313.80-318.82	-1.52	-0.0045	-1.47	.68±0.05	e0	2	2.18	39.7	160	28	29	0.0	a+2.6	135	42	42
1980	1	-11.1	341.68-346.84	-1.94	-0.0103	-1.84	.82±0.05	5	2	2.13	160	29	29	20.0	a+2.3	135	61	36	66
			196.61-200.80	-1.68	-0.0220	-1.46	.80±0.04	6	2	2.13	164	29	24	20.0	a+2.3	135	37	37	60
			200.80-203.68	-1.06	-0.0147	-0.91	.73±0.04	5	2	2.18	168	24	24	20.0	a+2.3	135	61	37	57±28
			203.68-210.69	-2.16	-0.0344	-1.82	.60±0.02	b43	14	2.18	62	9235	62	9235	20.0	a+2.3	135	27±15	12
1980	2	+8.6	84.68-91.70	+0.194	-0.0140	+0.208	0.87±0.05	5	4	1.92	40.0	176	24	0.0	a+1.3	135	59	36	71
			91.70-100.70	+1.90	-0.0342	+1.224	.87±0.05	5	2	1.90	40.0	176	24	0.0	a+1.3	135	61	36	71
			108.65-116.79	+1.33	-0.0342	+1.67	.72±0.03	3	2	1.79	34.8	176	25	0.0	a+1.5	184	61	33	61
			116.79-122.20	+1.01	-0.0236	+1.25	.81±0.04	3	2	1.92	40.0	172	29	0.0	a+1.3	135	59	36	66
1980	1	-11.1	122.20-128.71	+0.064	-0.0293	+0.093	.50±0.07	b36	16	1.90	40.0	51	9235	21.5	a+2.3	135	61	34±15	42±14
			262.65-262.67	-----	-----	-----	-----	-----	-----	-----	-----	-----	-----	-----	-----	a+0.3	135	59	32
1980	2	+6.6	220.70-275.76	-0.700	-0.222	-0.478	0.66±0.04	5	2	1.72	34.8	43	244	0.0	a+1.7	184	58	28	61
			both running together	-----	-----	-----	-----	-----	-----	-----	-----	-----	-----	-----	-----	a+1.7	135	58	30

aVoltage estimated from simulated ground tests, accuracy is ±0.6 v.

bProbe reading may be erroneously high.

cVoltage estimated from 16 current and supply impedance.

dSWAG.

eI-V9 was -44 v. (bias).

fIon current, mA = 491xThrust, mN + (Vnet)1/2.

g90ry.

TABLE 5. - REPRESENTATIVE HEATER VALUES<sup>c</sup> AND CATHODE STARTING TIMES

Thruster	Start number	Date	Main vaporizer			Main cathode			Neutralizer cathode			Cathode start time		Total cathode, on time, d	Neutralizer reservoir temperature, °C
			I2, A	V2, V	V2/I2,	I3, A	V3, V	V3/I3,	I7, A	V7, V	V7/I7,	Neutralizer cathode, min	Main cathode, min		
1	1	12/9/69	2.80	(a)	(a)	2.80	>15	>5.3	2.78	(a)	(a)	8.5	0.3	----	(a)
	4	12/28/69	2.81	(a)	(a)	2.92	15.7	5.4	2.79	9.9	3.6	6.2	.4	----	(a)
	5	2/14/70	2.81	2.74	0.98	2.88	15.7	5.5	2.90	10.3	3.6	3.3	.3	0	(a)
	6	3/8/70	2.89	(a)	(a)		15.3	5.3		10.6	3.7	4.2	.3	508	83
	7	5/21/70	(a)	2.67	(a)		15.3	5.3		10.8	3.7	4.3	.7	2283	78
	14	10/26/70	2.89	2.60	.90		14.1	4.9		10.8	3.7	4.2	b4.4	3794	47
	20	2/11/71	2.89	2.67	.93		15.7	5.5		10.3	3.6	4.2	.3	3855	83
	32	1/21/72	(a)	(a)	(a)		15.7	5.5	2.79	10.1	3.6	6.2	(a)	3868	29
	33	5/25/73	2.81	2.74	.97	2.82	15.3	5.4	2.90	10.6	3.7	6.6	b6.4	3869	(a)
	145	8/19/74	2.89		.95		15.3	5.4		10.8	3.7	6.3	7.4	3885	
	156	10/9/74	2.81		.98		15.7	5.6		10.3	3.6	6.8	9.5	3889	
	157	11/14/75	2.89		.95		15.3	5.4		10.6	3.7	6.4	3.8	3890	
	160	9/15/76	2.09	2.10	1.00		14.5	5.2				6.5	3.0	3891	
	167	12/14/76	2.70	2.74	1.01	2.88	15.7	5.5				5.8	7.2	3894	
	172	7/27/77	2.79	2.74	.98	2.82	(a)	(a)				6.6	7.5	3896	
	176	11/22/77	2.89	2.74	.95	2.82	14.9	5.3				5.8	3.1	3897	
	177	7/14/78		2.67	.92	2.88		5.2		10.3	3.6	6.5	2.9	3898	
	178	1/14/78		2.74	.95	2.88		5.2		10.6	3.7	5.1	1.5	3898	
	179	1/17/79		2.67	.92	2.82		5.3		10.3	3.6	4.8	1.0	3904	
	185	3/12/79		2.67	.92	2.82	14.5	5.2				4.8	4.0	4046	
	191	5/22/79		2.67	.92	2.88	14.9	5.2				6.6	6.7	4085	
	199	8/31/79	2.73	2.56	.94	2.82	14.1	5.0	2.90			5.3	1.7	4093	
	212	12/5/79	2.90	2.70	.93	2.82	14.1	5.0	2.94	10.6		6.2	3.2	4498	
	216	3/10/80	2.99		.91	2.82	14.4	5.1		10.6		5.8	3.3	4624	
222	7/15/80	2.90		.93	2.87	15.2	5.3		10.6		e4.4	2.7	5080		
228	8/17/80			.93	2.82	14.8	5.2		10.3	3.5	----	2.0	5164		
230	10/23/80		2.77	.96	2.87	15.2	5.3		10.3	3.5	----	2.0	6896		
240	12/1/80		2.70	.93	2.82	14.4	5.1		10.3	3.5	----	e2.7	7838		
2	1	11/29/69	2.89	(a)	(a)	2.78	>15	>5.4	2.94	(a)	(a)	10.0	1.0	----	(a)
	4	12/21/60	2.90	(a)	(a)	2.77	16.0	5.8	2.86	(a)	(a)	6.3	1.0	----	(a)
	10	2/11/70	2.88	2.77	.96	2.86	16.0	5.6	2.97	10.2	3.4	3.2	.4	0	97
	11	7/24/70	2.97	2.70	.91	2.86	16.0			10.2	3.4	3.2	.9	38	97
	12	9/2/70				2.81	15.6			10.4	3.5	3.7	.9	934	65
	53	11/13/70				2.81	15.6					2.8	.9	2094	69
	67	2/26/71				2.86	16.0					2.7	.4	2126	115
	76	1/21/72	(a)	(a)	(a)	2.86	16.0					5.3	(a)	2149	33
	126	7/17/73	2.97	2.70	.91	2.81	16.0	5.7				5.2	b8.2	2162	22
	189	8/19/74					15.6	5.6				5.4	10.5	2166	43
	203	9/12/74								10.2	3.4	6.1	22.5	2169	40
	211	10/2/74								10.2	3.4	6.8	12.7	2175	35
	215	12/4/75								10.4	3.5	7.4	29.3	2177	37
	216	9/22/76				2.86	15.0	5.3	2.92	10.2	3.5	6.2	b41.0	2178	30
	218	11/29/77					15.4	5.4		10.0	3.4	6.4	2.1	2279	33
	219	1/22/79					15.6	5.3		10.2	3.5	3.9	2.0	2342	62
	226	3/7/79					14.8	5.0		10.4	3.6	3.8	1.8	2757	62
	230	4/3/79		2.63	.89		14.1	4.8		10.2	3.5	3.2	6.7	2881	97
	234	9/10/79	2.99	2.70	.91	2.87	14.8	5.2	2.94	10.1	3.4	3.6	2.8	2890	62
	251	2/29/80		2.70	.91		14.8	5.2		10.1	3.4	4.2	3.6	2985	66
	261	3/25/80		2.63	.80		14.8	5.2		10.1	3.4	e6.0	3.3	3026	66
	275	8/9/80		2.70	.91		15.5	5.4		10.3	3.5	----	1.8	4200	59
	290	10/14/80		2.70	.91		15.5	5.4		10.3	3.5	----	2.0	5502	68
	300	12/1/80		2.63	.88		15.2	5.3		10.3	3.5	----	3.1	6542	115

<sup>a</sup>Data not taken or unavailable.

<sup>b</sup>No preheat used.

<sup>c</sup>Quantizing and calibration error, ±3 percent, root-sum-square.

<sup>d</sup>Includes heating time in space only; ground time, thruster 1 - 83 hr, thruster 2 - 91 hr.

<sup>e</sup>Last start before Hg tank depleted.

TABLE 6. - SUMMARY OF NEUTRALIZER FLOW RATES AND N<sub>2</sub> DIFFUSION RATES

(a) Neutralizer tank 1								
Period name	Operating period, hr	Differential hours		Mercury flow			Tank temp., °C	N <sub>2</sub> loss by diffusion (avg.), N/cm <sup>2</sup> /hr
		Oper.	Calendar	Space		Ground		
				Total, gms	Rate, mA	Rate, mA		
1969-70 prelaunch testing	0-83	83	1248	20	-----	40 (est)	23	0.006x10 <sup>-4</sup>
1970 normal beam, 250 mA	83-3877	3794	3815	650	22±2	18±1	98	0.27x10 <sup>-4</sup>
1971-79 restarts/storage	3877-4166	289	b81,100	66	40 (est)	-----	a35 to 60	0.02 to 0.12x10 <sup>-4</sup>
1979-80 plasma-mode operation	4166-4991	825	7600	188	46±6	47±10	105	0.35x10 <sup>-4</sup>
222 cool down, after flow periods	-----	-----	-----	0.9	-----	-----	-----	-----
1980 hot, Hg tank empty	c4991-6496	-----	1505	0	0	-----	105	8.3x10 <sup>-4</sup>

(b) Neutralizer tank 2								
Period name	Operating period, hr	Differential hours		Mercury flow			Tank temp., °C	N <sub>2</sub> loss by diffusion (avg.), N/cm <sup>2</sup> /hr
		Oper.	Calendar	Space		Ground		
				Total, gms	Rate, mA	Rate, mA		
1969-70 prelaunch testing	0-63	63	1224	20	-----	40 (est)	23	0.006x10 <sup>-4</sup>
1970 normal beam, 250 mA	63-2080	2017	5905	317	21±3	20±1	98	0.4x10 <sup>-4</sup>
1971-79 restarts/storage	2080-2359	269	b76,500	84	40 (est)	-----	a35 to 60	0.02 to 0.12x10 <sup>-4</sup>
1979-80 low beam, 85 mA	2359-2965	606	1750	133	35±6	36±2	98	0.4x10 <sup>-4</sup>
1980 plasma-mode operation	2965-3870	905	1004	389	45±6	47±10	105	0.5x10 <sup>-4</sup>
261 cool down, after flow periods	-----	-----	-----	1.1	-----	-----	-----	-----
1980 cold, Hg tank empty	4120-6300	-----	2170	0	0	-----	60	1.8x10 <sup>-4</sup>
1980 hot, Hg tank empty	6300-9200	-----	2900	0	0	-----	105	7.2x10 <sup>-4</sup>

<sup>a</sup>Temperature range due to various lengths of spacecraft shadowing periods.

<sup>b</sup>Hg lost through vaporizer during storage periods was calculated at 0.5 gm total for mission.

<sup>c</sup>N<sub>2</sub> pressure at zero counts (<0.17 N/cm<sup>2</sup>).

TABLE 7. - SUMMARY OF ESTIMATED FLOW RATES, MAIN TANK, SYSTEM 1

Operating period	Time, hr	Estimated flow, mA	Hg, gm
1969 prelaunch testing	83	291	181
1970 full beam (250 mA)	3794	291	8,260
1970-72 short-clearing tests	72	100	54
1973-78 operation (146 starts)	36	135	a41
240 starts: prestart overshoot	-----	---	62
cool down after flow	-----	---	9
1979-80 discharge operation:			
C anode (40 v.)	553	135	563
B anode (33 v.)	3390	184	4,660
Total used, estimated			13,830
Total loaded (useful)			14,050
Difference (1.6 percent)			220

<sup>a</sup>Includes 4 gm Hg estimated lost through vaporizer during storage periods (30° to 50° C).

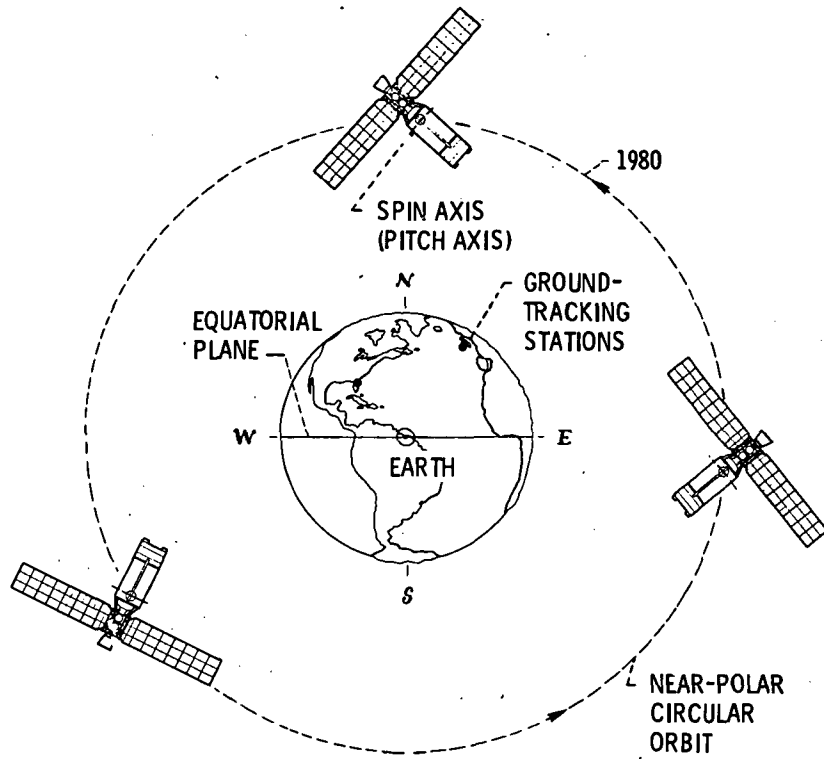

SPIN-STABILIZED POSITION

CD-9017

VEHICLE COORDINATE SYSTEM IN ORBIT VIEWED FROM SUN

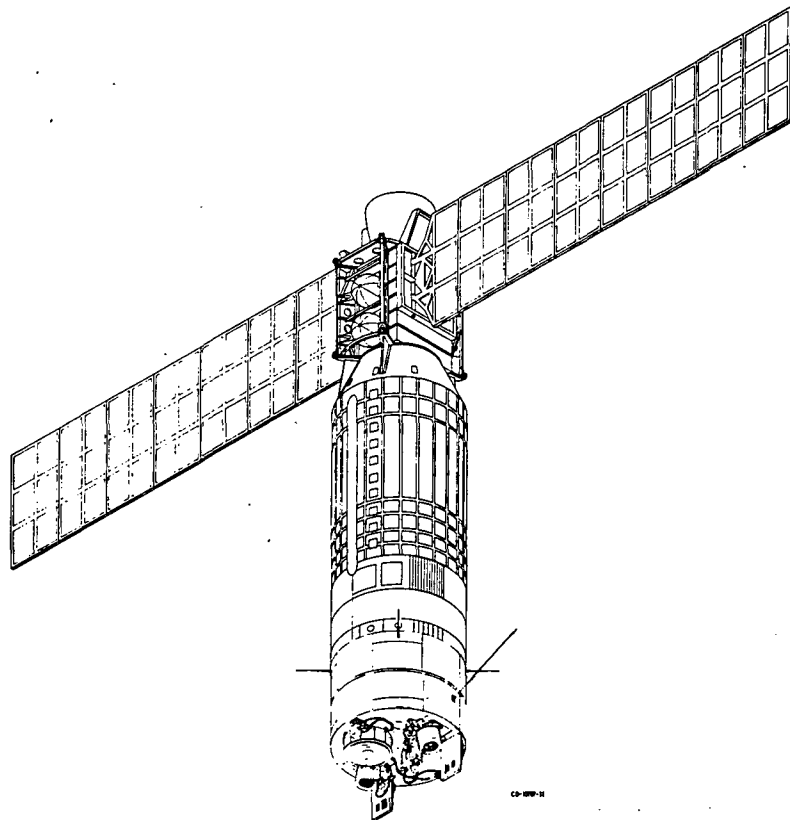
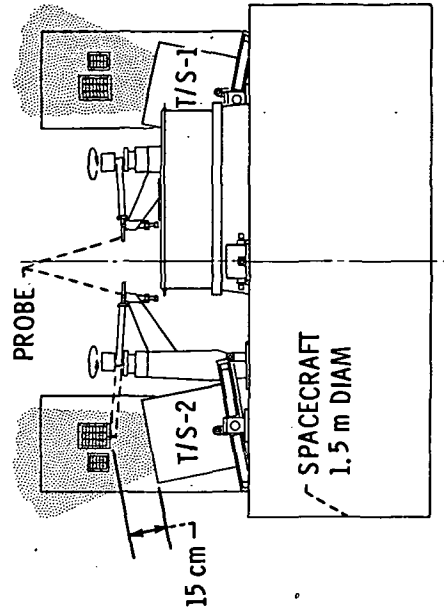
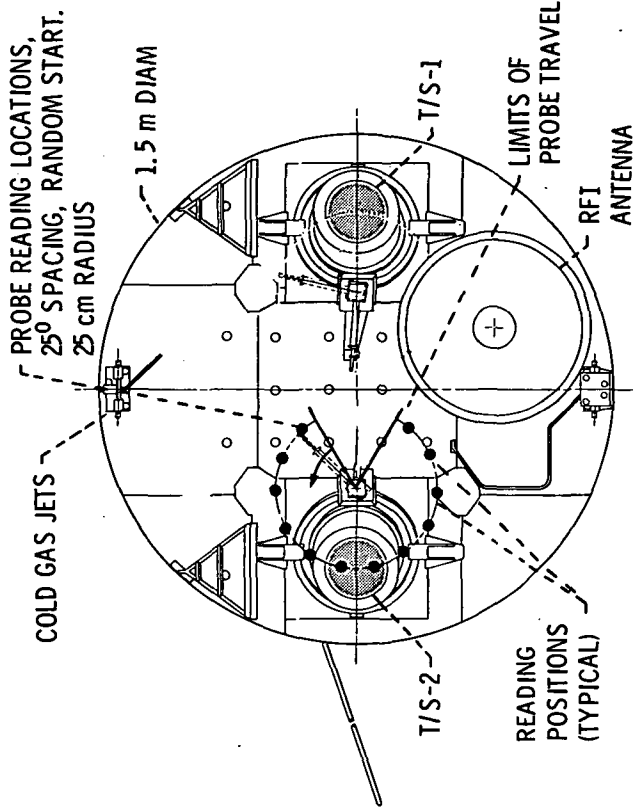

Figure 1. - SERT II spacecraft in orbit (artist's conception).





CD-10804-31

Figure 3. - SERT II spacecraft drawing showing beam probe location.

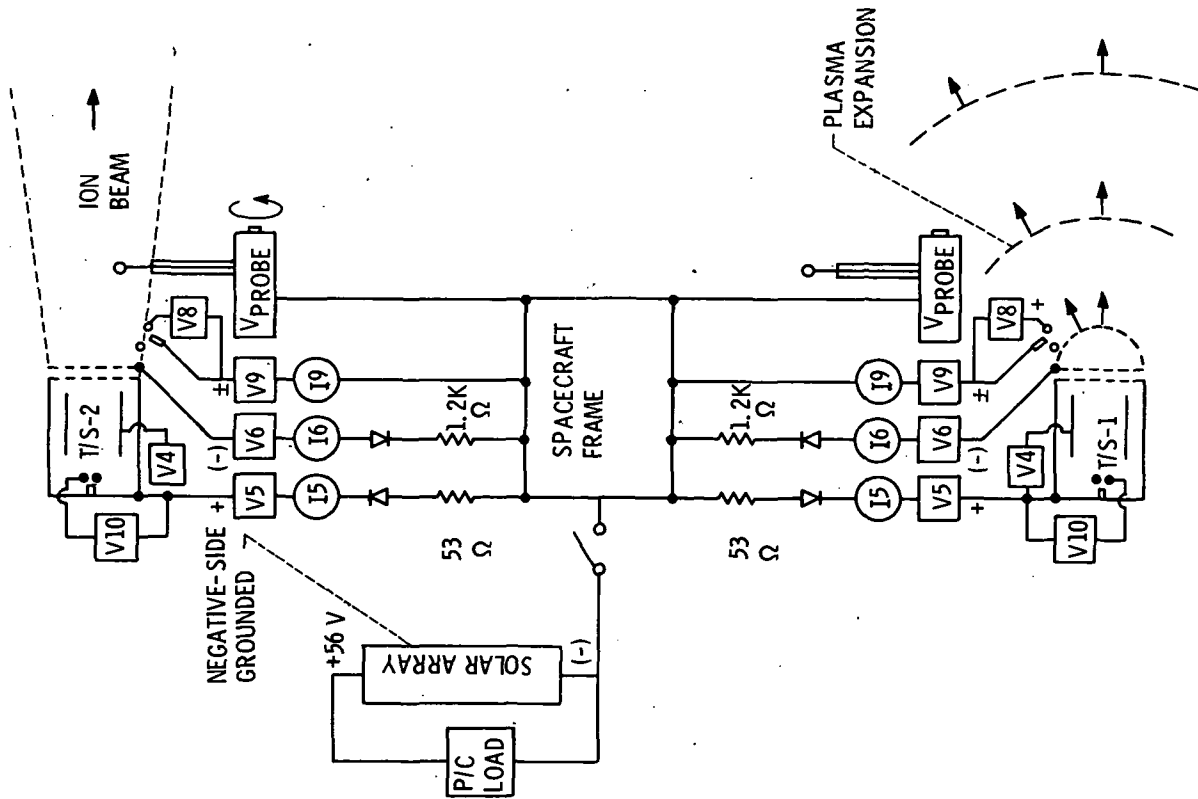
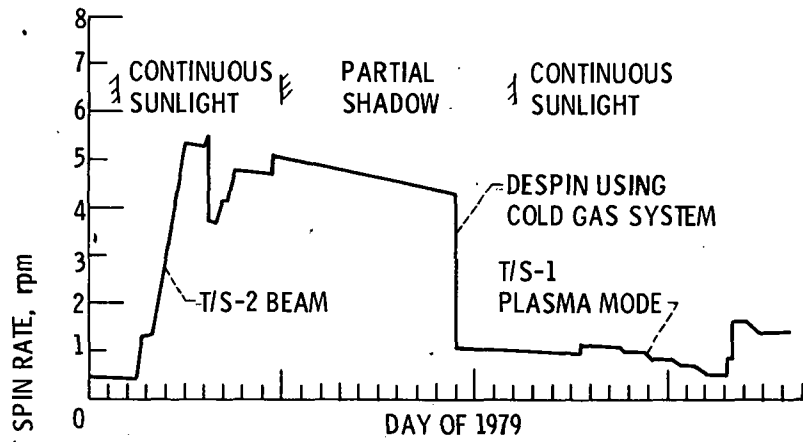
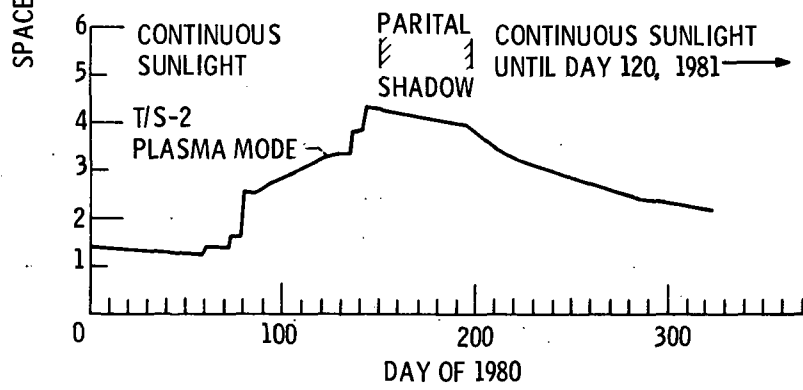

Figure 2. - SERT II power supply and solar array circuits.



(a) 1979.



(b) 1980.

Figure 4. - Plot of SERT II spacecraft spin rate.

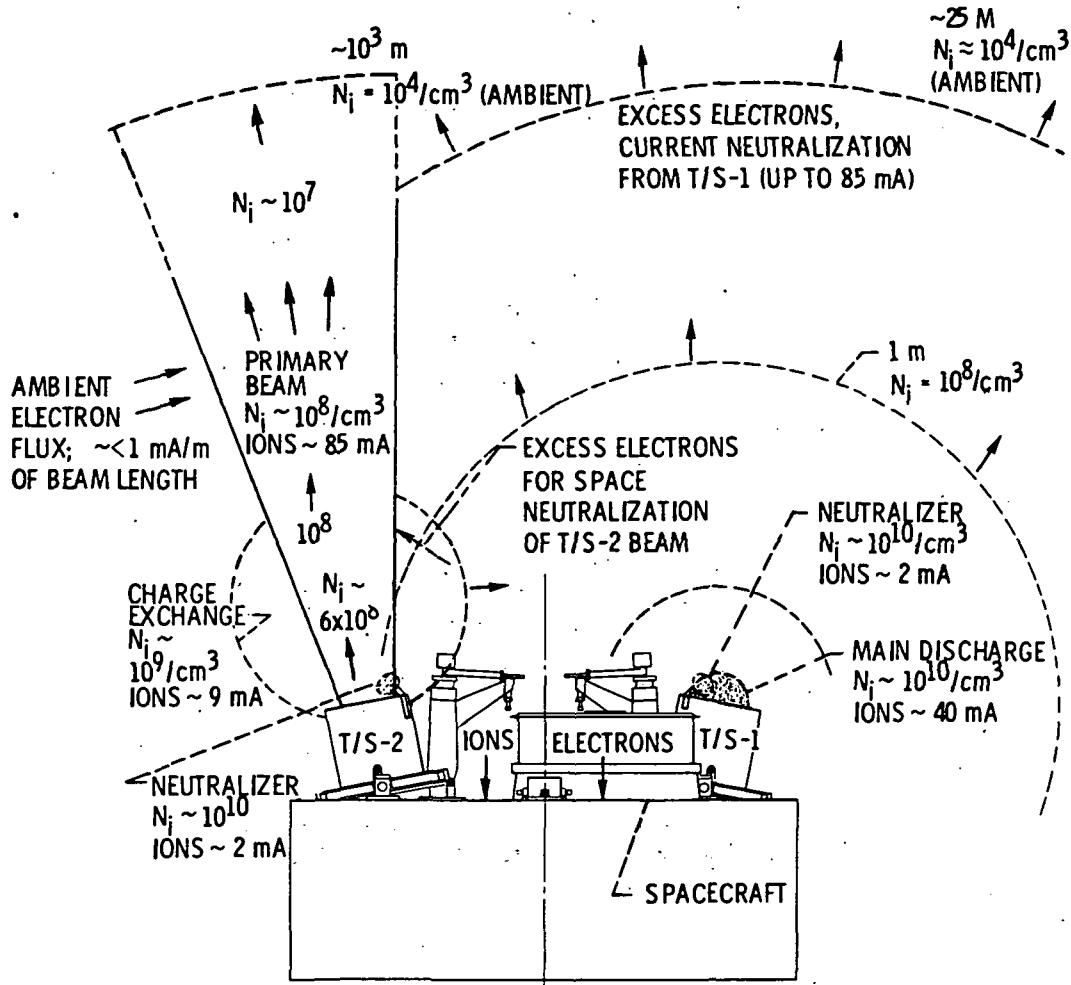

CD-10804-31

Figure 5. - Spacecraft plasma current diagram.

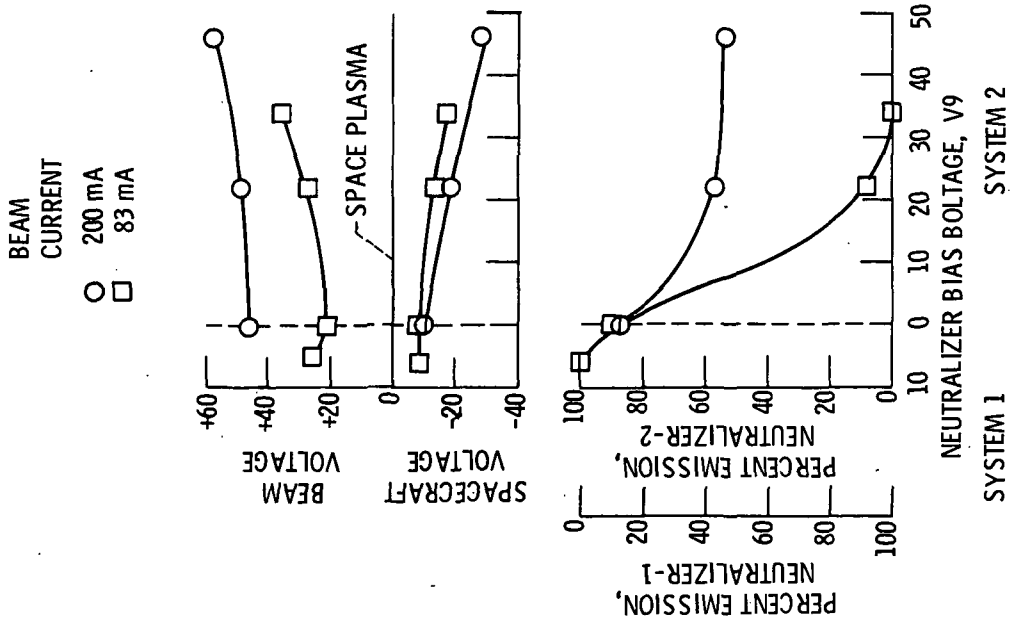

Figure 6. - Cross neutralization of thruster 2 at two beam current levels.

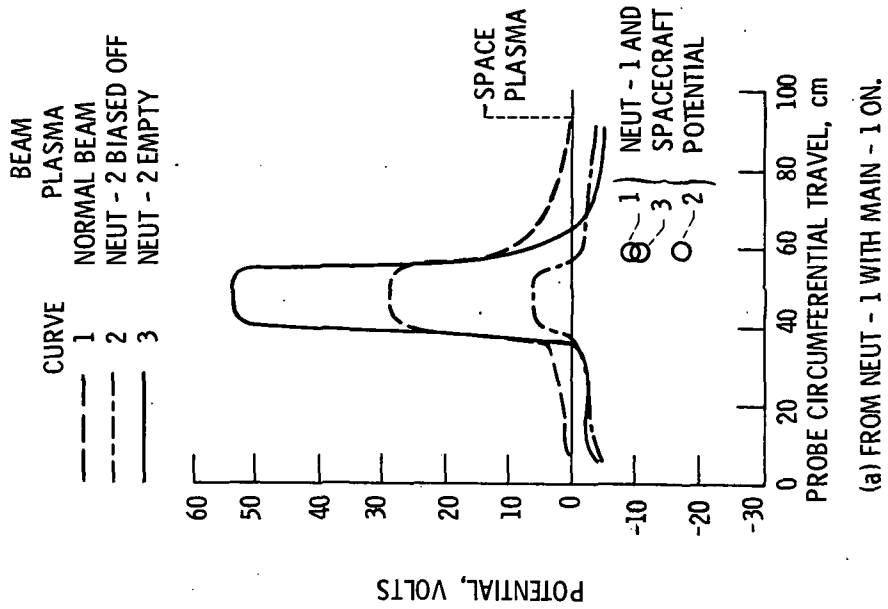
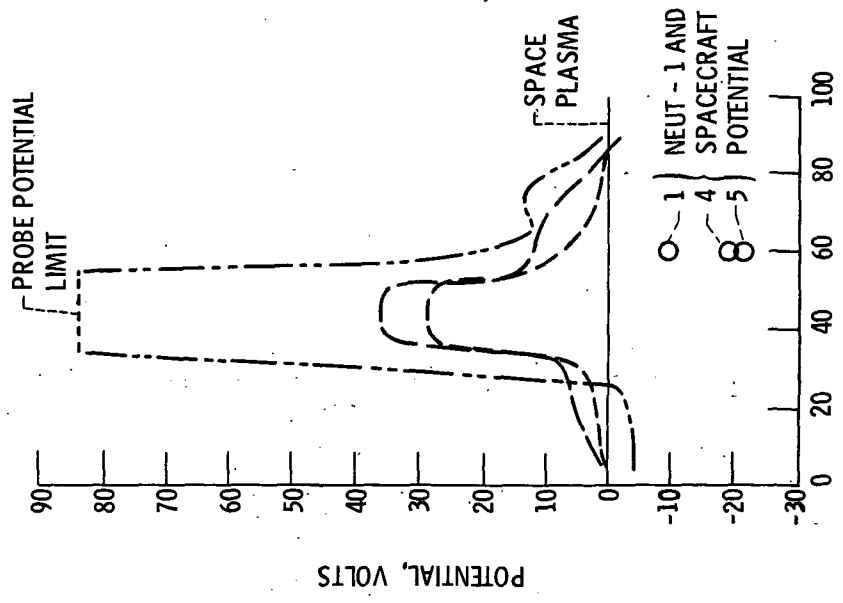

Figure 7. - Beam plasma potential plots for various types of neutralization of thruster 2 beam.

BEAM  
PLASMA

CURVE  
1  
4  
5

NORMAL BEAM  
NEUT - 2 BIASED OFF  
NEUT - 2 EMPTY



(b) FROM NEUT - 1 WITHOUT MAIN - 1 ON.

Figure 7. Continued.

CURVE  
6

NEUTRALIZATION FROM MAIN 1

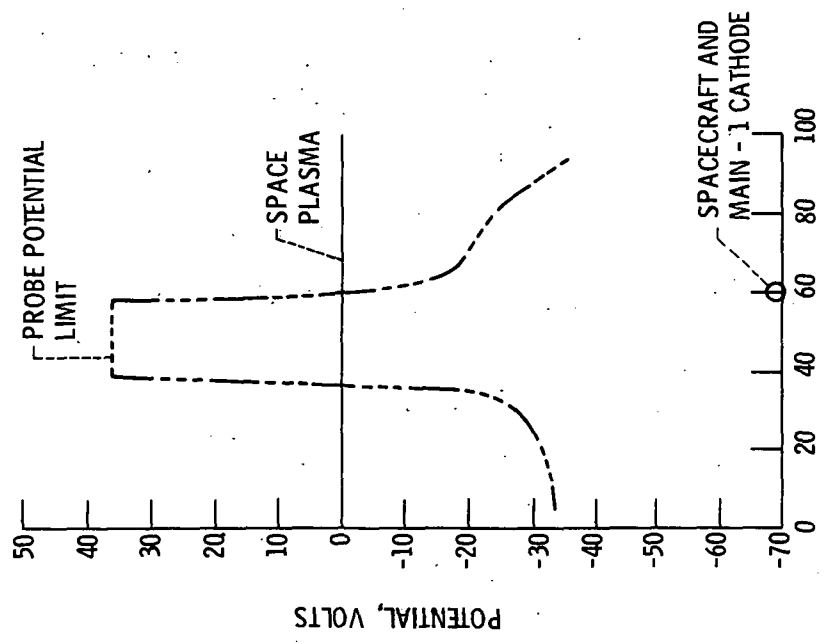

(c) NEUTRALIZATION FROM MAIN - 1 CATHODE ONLY.

Figure 7. - Concluded.

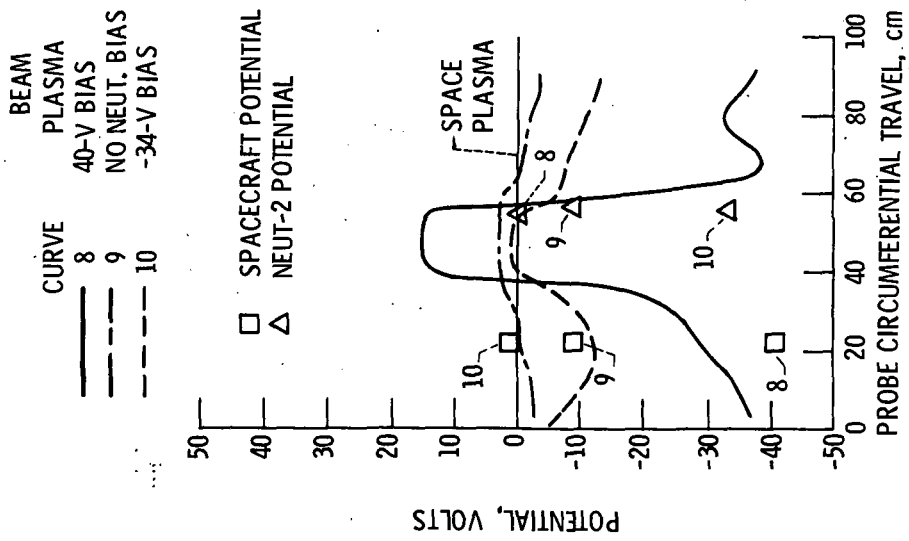
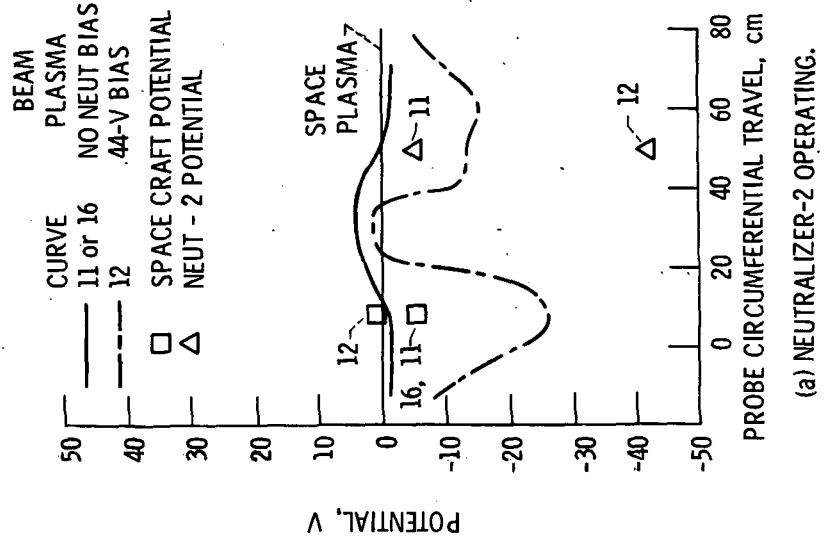

Figure 8. - Thruster 2 in low-mode operation. Beam current, 10 mA. Various neutralizer biases. (See Table 3 for other parameters.)



(a) NEUTRALIZER-2 OPERATING.

Figure 9. - Measured plasma potential of thruster 2 in plasma thrust mode. (see Table 3 for other parameters.)

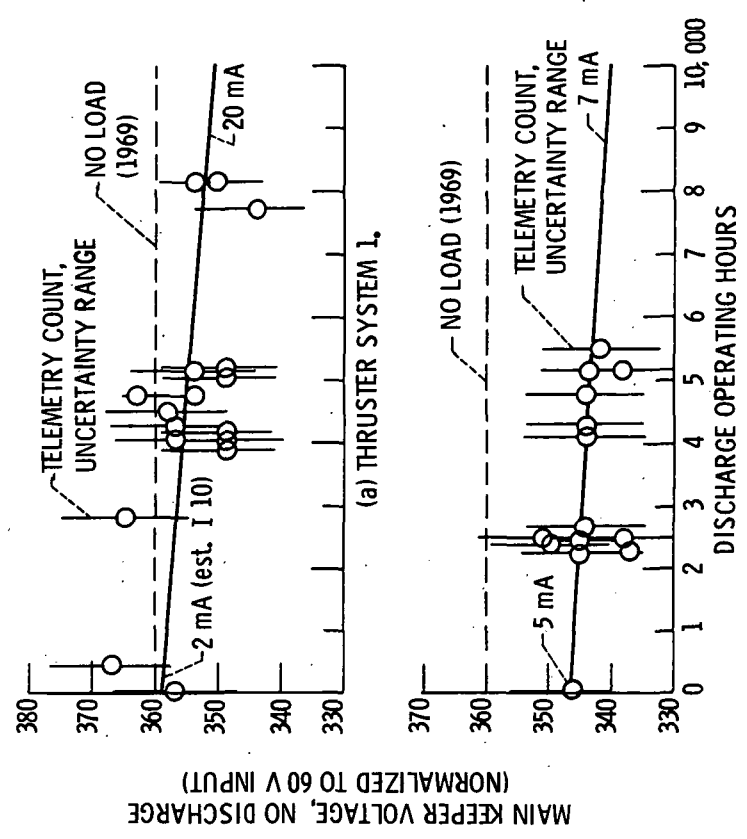
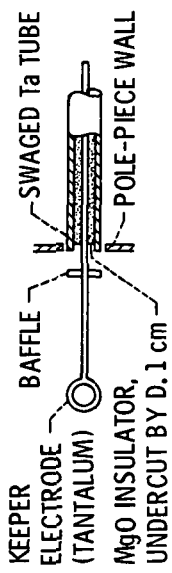

Figure 10. - Main keeper insulator reliability.

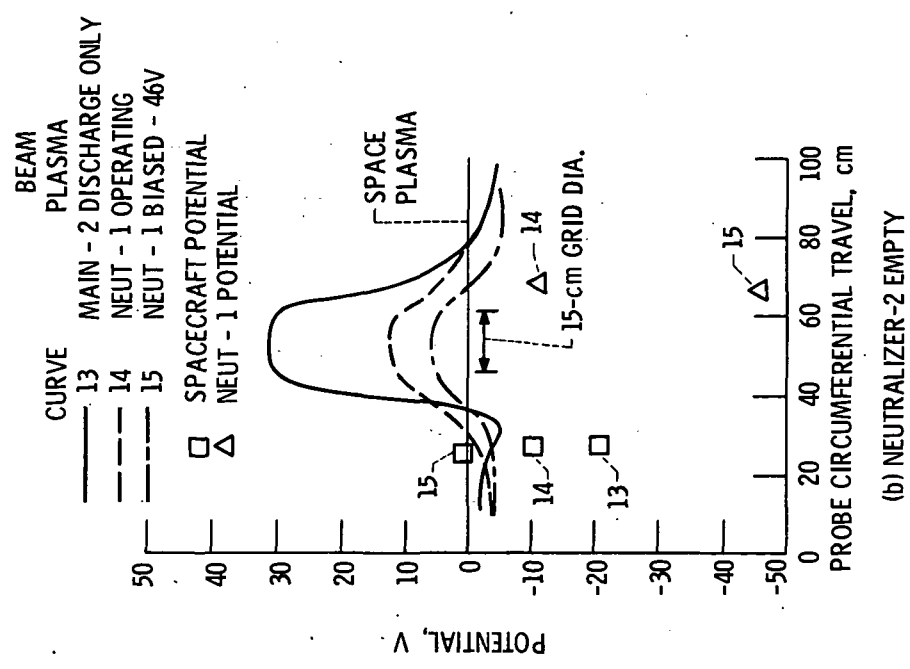

Figure 9. - Concluded.

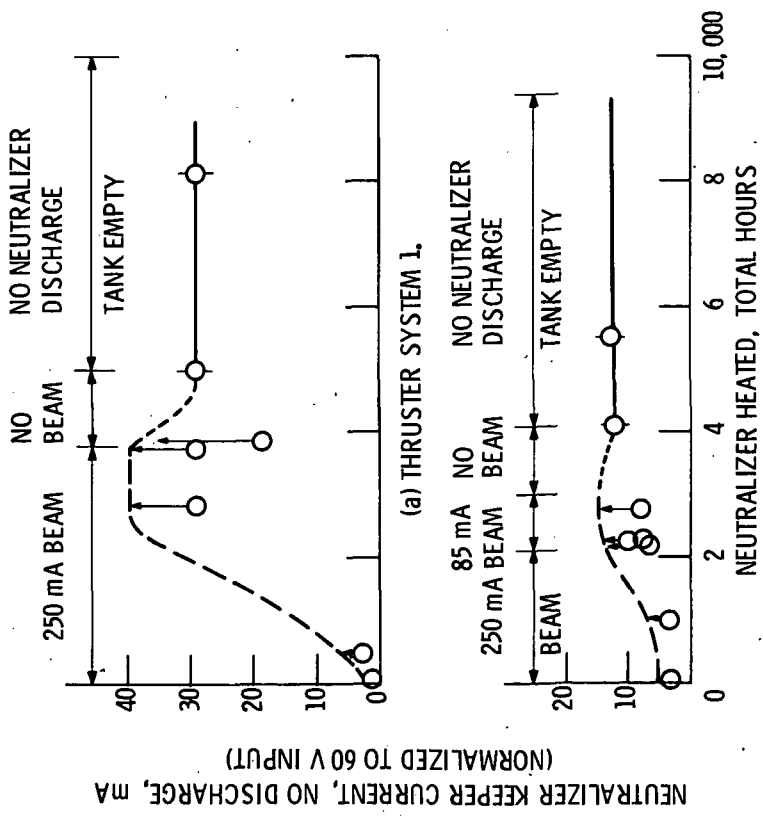
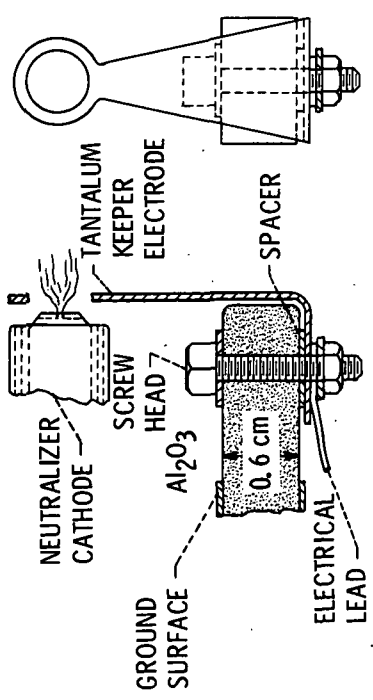

Figure 11. - Neutralizer keeper insulator reliability.

THRUSTER SYSTEM	TEST DATE
1	193 1979
2	130 1980

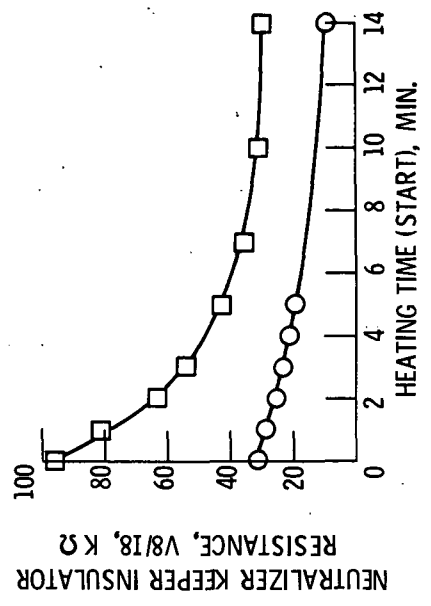

Figure 12. - Change in neutralizer keeper insulator resistance with cathode heating time. No discharge, both Hg tanks are empty.



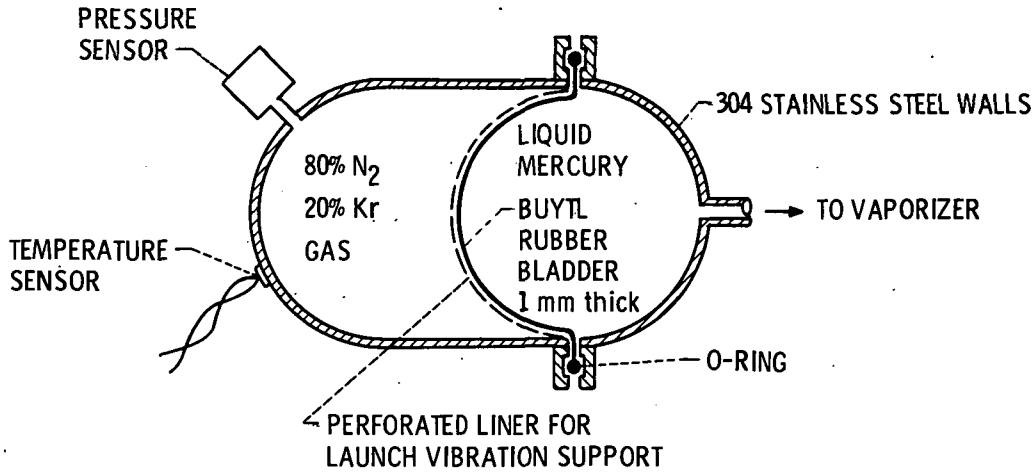
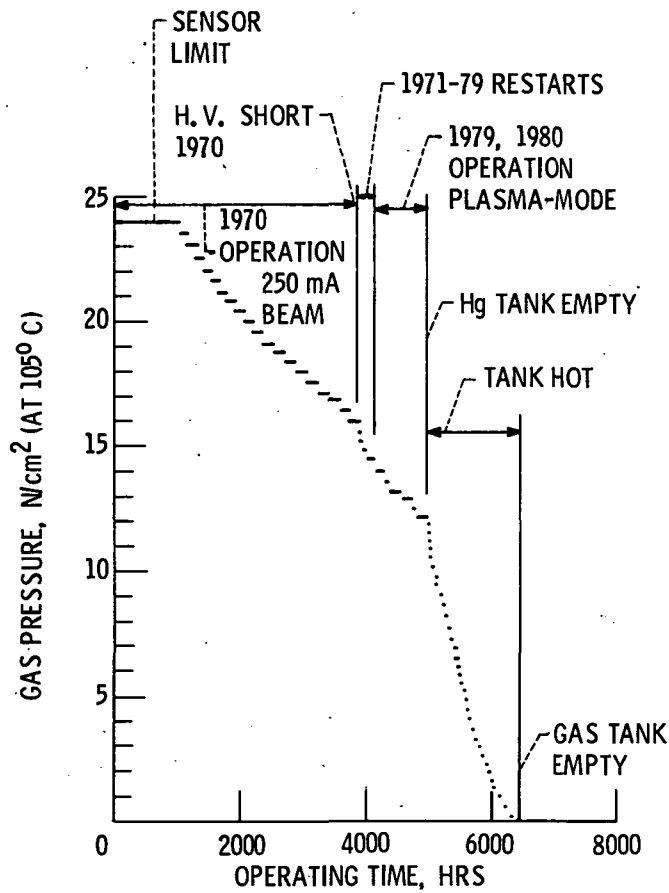
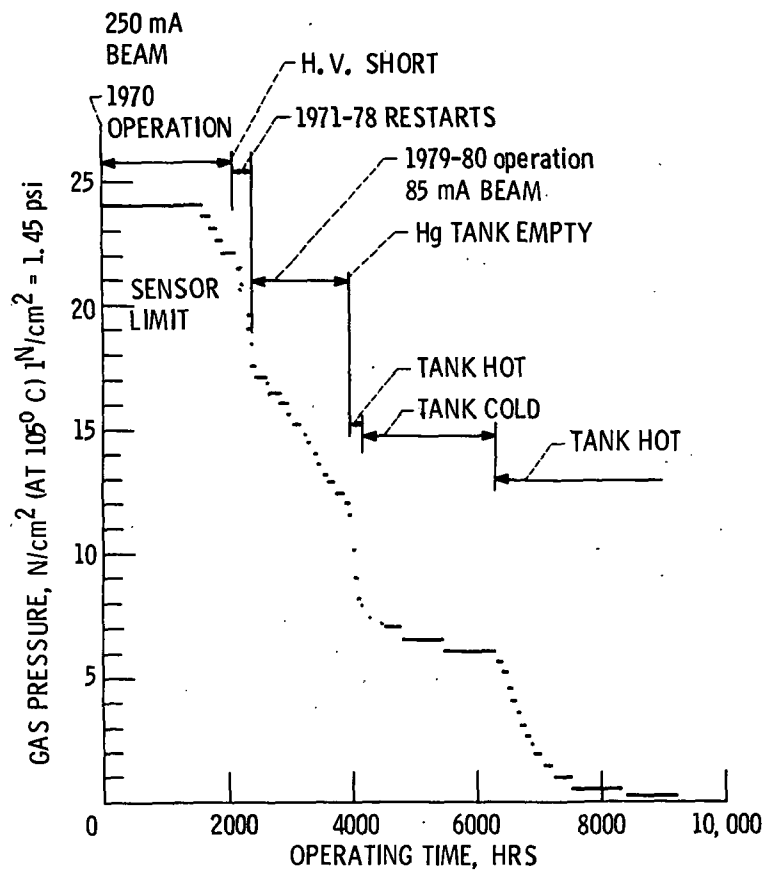

Figure 13. - Schematic of neutralizer propellant tank construction design.



(a) NEUTRALIZER TANK - 1.

Figure 14. - History of neutralizer tank pressure.



(b) NEUTRALIZER TANK - 2.

Figure 14. - Concluded. History of neutralizer tank pressure.

1. Report No. NASA TM-81685	2. Government Accession No.	3. Recipient's Catalog No.	
4. Title and Subtitle SERT II 1980 EXTENDED FLIGHT THRUSTER EXPERIMENTS		5. Report Date	
		6. Performing Organization Code 506-55-32	
7. Author(s) W. R. Kerslake and L. R. Ignaczak		8. Performing Organization Report No. E-695	
		10. Work Unit No.	
9. Performing Organization Name and Address National Aeronautics and Space Administration Lewis Research Center Cleveland, Ohio 44135		11. Contract or Grant No.	
		13. Type of Report and Period Covered Technical Memorandum	
12. Sponsoring Agency Name and Address National Aeronautics and Space Administration Washington, D.C. 20546		14. Sponsoring Agency Code	
		15. Supplementary Notes Prepared for the Fifteenth International Electric Propulsion Conference cosponsored by the American Institute of Aeronautics and Astronautics, the Japan Society for Aeronautical and Space Sciences, and Deutsche Gesellschaft fur Luft- und Raumfahrt, Las Vegas, Nevada, April 21-23, 1981.	
16. Abstract The SERT II spacecraft, launched in 1970, has been maintained in an operational, but intermittent status since 1971. This paper presents the flight results obtained from mid 1979 through December 1980. Near continuous solar power in 1979 and 1980 has enabled long periods of thruster endurance testing. Three of four propellant tanks have been exhausted with no significant change in thruster system operation before being empty. A new plasma mode thrust has been characterized and direct thrust measurements obtained. Other tests, including beam neutralization by various neutralizer sources, give insight to electron conduction across plasmas in space and provide a basis to model neutralization of thruster arrays.			
17. Key Words (Suggested by Author(s)) Ion thruster Spacecraft propulsion		18. Distribution Statement Unclassified - unlimited STAR Category 20	
19. Security Classif. (of this report) Unclassified	20. Security Classif. (of this page) Unclassified	21. No. of Pages	22. Price

National Aeronautics and  
Space Administration

Washington, D.C.  
20546

Official Business

Penalty for Private Use, \$300

SPECIAL FOURTH CLASS MAIL  
BOOK

Postage and Fees Paid  
National Aeronautics and  
Space Administration  
NASA-451



**NASA**

POSTMASTER: If Undeliverable (Section 158  
Postal Manual) Do Not Return

---