

26 May 2010, 4:45 pm - 6:45 pm

Shake Table Testing to Quantify Seismic Soil-Structure-Interaction of Underground Structures

Robb Eric S. Moss
California Polytechnic State University, San Luis Obispo, CA

Vic Crosariol
California Polytechnic State University, San Luis Obispo, CA

Steven Kuo
California Polytechnic State University, San Luis Obispo, CA

Follow this and additional works at: <https://scholarsmine.mst.edu/icrageesd>



Part of the [Geotechnical Engineering Commons](#)

Recommended Citation

Moss, Robb Eric S.; Crosariol, Vic; and Kuo, Steven, "Shake Table Testing to Quantify Seismic Soil-Structure-Interaction of Underground Structures" (2010). *International Conferences on Recent Advances in Geotechnical Earthquake Engineering and Soil Dynamics*. 22.

<https://scholarsmine.mst.edu/icrageesd/05icrageesd/session01b/22>



This work is licensed under a [Creative Commons Attribution-Noncommercial-No Derivative Works 4.0 License](#).

This Article - Conference proceedings is brought to you for free and open access by Scholars' Mine. It has been accepted for inclusion in International Conferences on Recent Advances in Geotechnical Earthquake Engineering and Soil Dynamics by an authorized administrator of Scholars' Mine. This work is protected by U. S. Copyright Law. Unauthorized use including reproduction for redistribution requires the permission of the copyright holder. For more information, please contact scholarsmine@mst.edu.



Fifth International Conference on

Recent Advances in Geotechnical Earthquake Engineering and Soil Dynamics and Symposium in Honor of Professor I.M. Idriss

May 24-29, 2010 • San Diego, California

SHAKE TABLE TESTING TO QUANTIFY SEISMIC SOIL-STRUCTURE- INTERACTION OF UNDERGROUND STRUCTURES

Robb Eric S. Moss, Ph.D., P.E.

Assistant Professor
California Polytechnic State University
San Luis Obispo, CA 93401

Vic Crosariol

Graduate Researcher
California Polytechnic State University
San Luis Obispo, CA 93401

Steven Kuo

Undergraduate Researcher
California Polytechnic State University
San Luis Obispo, CA 93401

ABSTRACT

This research uses shake table testing of scale soil-structure models to mimic the coupled seismic response of underground structures and surrounding/supporting soil (termed soil-structural-interaction or SSI). Currently the seismic design of subways and other critical underground infrastructure rely on little to no empirical data for calibrating numerical simulations. This research is working towards filling that empirical data gap. The research is composed of two phases, the first a validation of the free-field response of a flexible wall barrel filled with model soil, the second a test to measure the “racking” deformations induced in a model subway cross-section embedded in the model soil. San Francisco Young Bay Mud (YBM) is used as the prototype soil and the Bay Area Rapid Transit (BART) underground subway cross-section the prototype structure. Results are shown from the completed first phase of the test, and a presentation of the second phase test results is anticipated at the time of the conference. This research is a collaborative project between California Polytechnic State University (Cal Poly) in San Luis Obispo, California, and Nanjing University of Technology (NJUT) in Nanjing, China.

INTRODUCTION

There are many poorly understood seismic issues associated with critical infrastructure in seismic areas around the world. This project is collaborative research between researchers in the U.S. and China therefore the emphasis here is those countries. The U.S. has aging infrastructure such as bridges, subways, and buildings that were designed based on older seismic criteria which do not necessarily capture the full dynamic response. The U.S. also has new infrastructure being planned or built that may be limited in the scope of design because of unanswered seismic soil-structure-interaction (SSI) questions. China is trying to keep pace with its rapidly developing economy by building infrastructure at a frantic pace. However standard seismic design and seismic codes are not necessarily keeping up with the pace of development. This research project is being used to establish a parallel testing platform to be run simultaneously by researchers at Cal Poly San Luis Obispo and at Nanjing University of Technology for addressing these seismic research needs.

Recent research has shown that there is uncertainty in the dynamic response of soil sites (Bazzurro and Cornell 2004) and the coupled response of structures and the surrounding/supporting soil (Hashash et al. 2001; Stewart et

al. 1999). Some examples of U.S. infrastructure that warrant SSI research include: elevated highways, underground light rail and subways, bridges, overpasses, water canals, water supply tunnels, pipelines, levee systems, and dams. Research into the dynamic response of U.S. infrastructure mainly addresses seismic integrity, seismic hazard mitigation, and seismic retrofit. In China the infrastructure that warrants SSI research is similar in scope but mainly addresses initial planning and design.

This research project targets the seismic design of subways and other similar underground structures. A scale model testing platform has been developed for 1D shake table tests that mimics the dynamic free-field conditions of a soil column of soft cohesive soil subjected to seismic loading. In this soil column a model structure is embedded to measure what are commonly called “racking” deformations or deformations of the top with respect to the bottom of the embedded structure. The stiffness ratio of the soil to the structure results in the soil-structure-interaction. These measured “racking” deformations will be modeled numerically using equivalent linear (FLUSH) and non-linear (ABAQUS) soil-structure-interaction programs to expand the applicability of the empirical results.

TESTING PLATFORM

In physical testing, and scale model testing in particular, the testing equipment and physical model details can demand the bulk of the research efforts. This project is no exception. The first year of this project was spent acquiring the necessary materials, fabricating and modifying the testing equipment, and calibrating the testing platform. To carry out scale model tests on the shake table, similitude analysis dictates the scaling of important variables like dynamic soil strength, dynamic structural response, and co-seismic displacements. The similitude analysis and scaling of the soil and structural elements used follows the research by Meymand (1998).

The central piece of testing equipment is a flexible wall barrel that mimics free-field seismic site response when subjected to shaking on the shake table. Validation of the testing platform involves comparing analytical results with recorded response from the flexible wall barrel. Figures 1 and 2 show the validation by Meymand (1998) demonstrating the dynamic performance of the flexible barrel versus other testing containers. As can be seen the flexible wall barrel provides the most accurate representation of seismic soil response with respect to the prototype soil column as modeled numerically using QUAD4M (Hudson et al. 1994).



Figure 3. Testing platform showing the shake table with the flexible wall barrel. The flexible wall barrel is composed of the four corner posts with universal joints at the top and bottom, the top and bottom rings, and the barrel wall. The wall is composed of a 6.4 mm thick rubber membrane which is confined by 45 mm wide Kevlar straps spaced on center every 60 mm. The (yellow) mixer on the left is used to mix the large volumes of model soil (composed of kaolinite, bentonite, fly ash, and water).

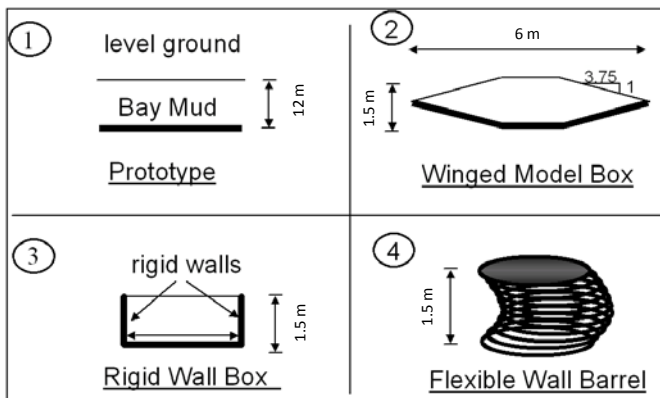

Figure 1. Different model soil containers for SSI shake table testing (after Meymand 1998).

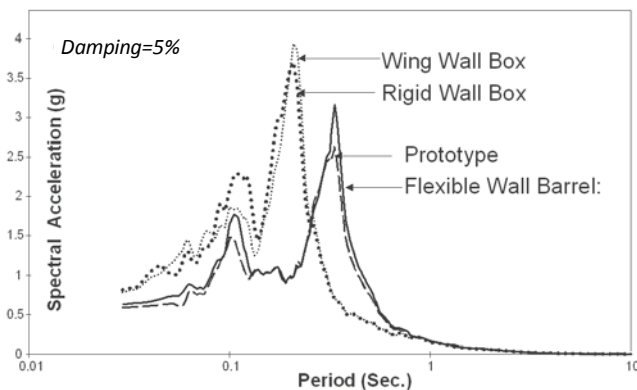

Figure 2. Dynamic analysis of different model soil containers, showing that the flexible wall barrel provides the most realistic response when compared to prototype field conditions (after Meymand 1998).

The flexible wall barrel and associated equipment was assembled on the 1D shake table in the Parsons Earthquake Lab at Cal Poly, and the mixing of an appropriate model soil was carried out. Figure 3 shows the flexible wall barrel assembled on the shake table awaiting the model soil. Figure 4 shows the filling of the barrel and Figure 5 shows the full barrel awaiting shake table testing.

The model soil for these tests adheres to similitude analysis to ensure properly scaled response. The geometry scale for these tests is 10^{th} scale, which is equivalent to the similitude parameter λ . In similitude analysis it is not possible to scale all the physical parameters simultaneously. For this research dynamic strength of the soil was chosen as the primary physical parameter to mimic, and the model soil was designed accordingly. A mix of 67.5% kaolinite, 22.5% bentonite, 10% fly ash, and water is used in specific proportions to achieve the desired strength range. The mix is at an average 130% water content and the target undrained strength of $s_u=4$ kPa from a UU (unconfined undrained) triaxial test is the guide prior to large volume soil mixing. Once the flexible wall barrel was filled, T-bar pull out tests and shear wave velocity tests measure the *in situ* model soil strength during each step of shake table testing.

The Parsons Earthquake Lab at Cal Poly has a 1D shake table with a 9000 kg payload capacity. Under the maximum payload the table can accelerate up to 1g, has a maximum velocity of 97 cm/sec, a maximum peak to peak displacement of 25 cm, and operates in the frequency range of 0.1 to 50 Hz. A full flexible wall barrel and accompanying equipment is estimated to weigh on the order of 7000 kg.



Figure 4. Process of filling the barrel with scale model soil. Ten accelerometers were placed in the soil lifts in both vertical and horizontal arrays to record the dynamic response of the soil during shaking.



Figure 5. Shown is a full barrel being prepared for initial calibration tests. Note the cross bracing still in place that will be removed prior to testing to allow the flexible wall barrel free movement in response to the imposed shaking.

PHASE 1 TESTING

The first phase was to perform free-field tests to measure the dynamic response of the soil column without the influence of the underground structure and provide a baseline for evaluating the effects of the soil on the structure. The ground motions selected for table input are;

1. 1979 Imperial Valley, El Centro motion
2. 1992 Landers, Joshua Tree motion
3. 1999 Chi Chi, TCU075 motion

These motions were selected specifically to impose large adverse loads on an underground structure. These were also the same motions selected and peer reviewed for a tunnel related consulting project similar to the subway prototype.

Both horizontal azimuths from each motion were run through the table. To adhere to the similitude analysis and provide the correct dynamic response, time is scaled at $\lambda^{0.5}$. This means the time step of the ground motions are compressed to $\Delta t / \lambda^{0.5}$ for table input. These motions are also corrected for full ground reflection because they were recorded at the ground surface but are used as table input at the base of the flexible wall barrel. This was accomplished by subtracting the full reflection of an “outcrop” motion to render a “within” motion with respect to the prototype soil profile.

The instrumentation for these tests includes 10 accelerometers, 3 displacement transducers, a load cell, and a digital video capture for image processing to resolve displacement with time. Static soil strength tests conducted before and after shaking tests include top down hammer blows to measure travel time of shear waves as captured by the accelerometer array and T-bar pull out tests that measure undrained shear strength from which a correlated shear wave velocity is estimated. Figure 6 shows the plan view layout of the accelerometer array and the T-bar locations. The accelerometers arrangement is composed of a central array to measure the average model soil column response, an off center array in anticipation for the second phase of the test when the model subway cross-section will be embedded in the soil column, and accelerometers near the edges to measure any boundary effects due to the flexible wall barrel assembly. The shear wave velocity profile of the model soil column is shown in Figure 7. Full details of the testing, procedures, and results can be found in Crosariol (2010).

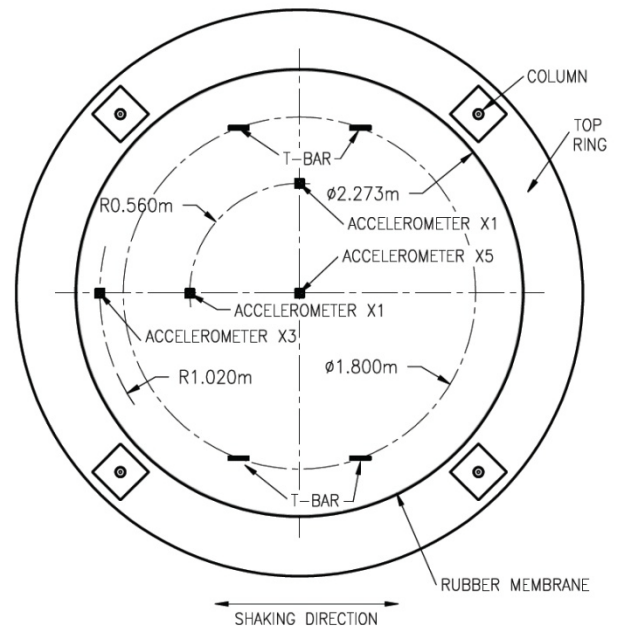

Figure 6. Top down plan view of the flexible wall barrel showing the accelerometer array layout, T-bar locations, and radial dimensions.

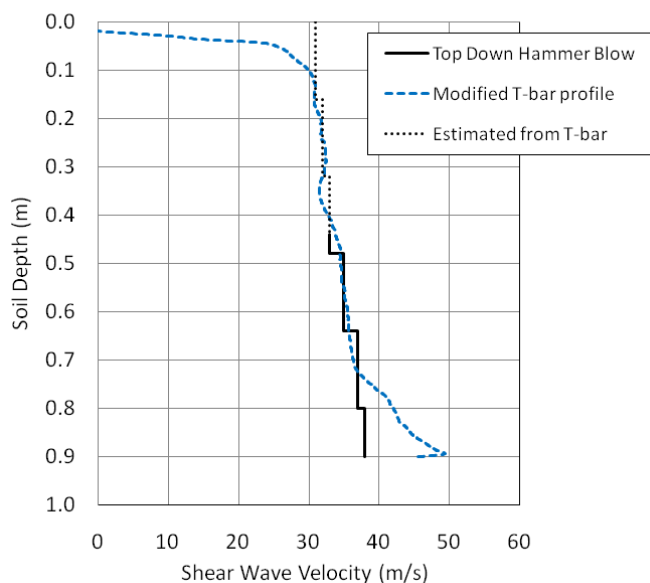

Figure 7. Shear wave velocity profile from Phase 1 tests. Shear wave velocity was measured using top down hammer blows and correlated estimates from bottom up T-bar tests.

To validate the flexible wall barrel free-field response, the spectral acceleration recorded from the model soil column is compared to the expected response from the prototype soil column as modeled using a 1D equivalent linear, SHAKE (Idriss et al., 1992), numerical analysis. The prototype profile consists of approximately 10 m of soft clay soil, similar to Young Bay Mud, overlying a rock base. Figure 8 shows that the flexible wall barrel does an adequate job of capturing the free-field soil response across the frequency spectrum and reasonably captures the peaks at the site period (~0.45 sec) and the two higher modes.

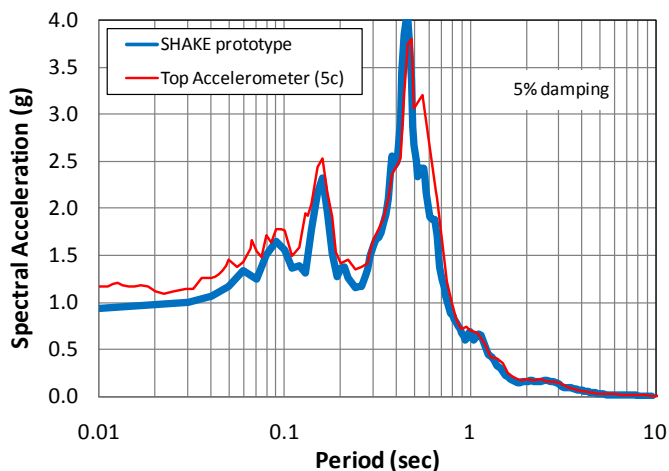

Figure 8. Comparison of the free-field flexible barrel recording at the model soil surface versus SHAKE results of the prototype soil profile. The input motion here is the 1979 Imperial Valley El Centro 180 recording.

PHASE 2 TESTING

An underground section of the BART (Bay Area Rapid Transit) light rail was chosen as the prototype tunnel cross-section for the SSI tests. This structure is also similar to light rail tunnels being considered in the Jiangsu province of China. A scale model structure adhering to the similitude scaling of the structural stiffness of the BART tunnel cross section was assembled. Of primary research and design interest is the “racking” of the structure, which is the relative displacement of the top of the tunnel section with respect to the bottom of the tunnel section during seismic loading. This tends to be the critical cross-sectional design variable for underground tunnels undergoing seismic SSI in softer soils (Hashash et al. 2001). Our model cross section, shown in Figure 9, is instrumented with a laser displacement sensor that tracks the relative deformations from the top to the bottom of the cross-section during shaking.

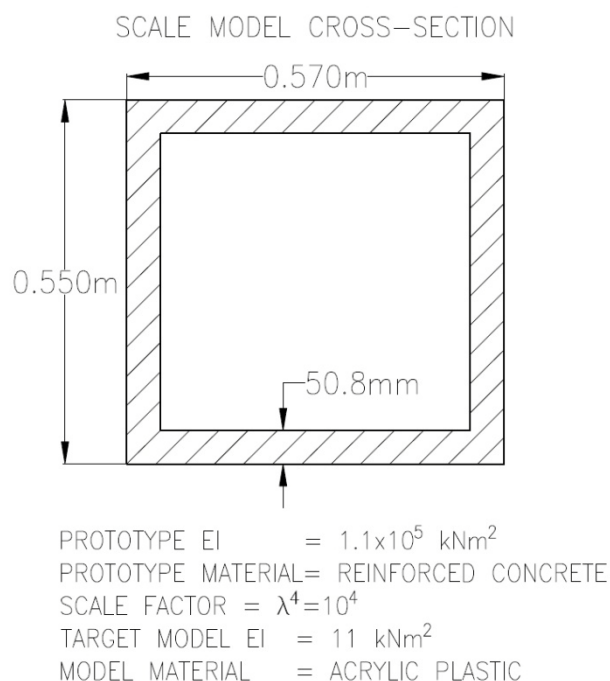

Figure 9. The prototype subway cross-section is based on a single tube of a typical BART underground section. The dimensions, prototype, and model properties are shown.

Numerical modeling of Phase 2 uses equivalent linear results to model the free-field baseline and other codes to accommodate the structural elements and the soil-structure-interaction. FLUSH (Lysmer et al. 1975) is used to perform 2-D equivalent linear analysis while including the embedded structure to provide SSI analysis of the prototype soil profile with the subway cross section. The free-field response in FLUSH is calibrated using SHAKE results and then structural “racking” strains are calculated. A similar numerical analysis is performed using the nonlinear code ABAQUS (Simulia 2009) to capture any highly non-linear response that is missed using an equivalent linear approach. The purpose of the

modeling is to take the empirical results from the shake table tests and explore the range of “racking” deformations when the stiffness ratio, dynamic loading, and other pertinent parameters are varied. This will expand the results beyond what can be accomplished on the shake table in the given time frame and budget, but will be grounded by the deformations measured in the scale model tests. Results from Phase 2 are anticipated by the time of the conference.

SUMMARY

This manuscript presents research delving into the seismic soil-structure-interaction (SSI) of a subway in soft clayey soil. The goal of this research is to provide an empirical basis for the “racking” deformations that are a design reality of underground SSI projects. A 1g tenth scale model testing platform was developed for dynamic testing on the shake table. The platform is composed of a flexible wall barrel, scale model soil, and associated testing hardware. The first phase of the research, free-field testing, was completed by the time of manuscript submission. The response of the flexible wall barrel testing platform is shown in Figure 8 to adequately mimic the prototype soil column as validated using 1D equivalent linear (SHAKE) numerical analysis. The results of the second phase of the research, where a subway cross-section is embedded in the model soil column, will be forth coming at the conference presentation. The empirical results will be modeled using equivalent linear and non-linear soil-structure-interaction codes (FLUSH and ABAQUS) to expand upon the measured data and cover a wider range of field conditions that tunnel engineers might experience.

ACKNOWLEDGEMENTS

The authors would like to acknowledge the financial support that made this research possible. This project was sponsored by the Department of the Navy, Office of Naval Research, under Award # N00014-07-1-1152 and Award # N00014-08-1-1209. Any opinions expressed are those of the authors and not the funding agency. The College of Engineering at Cal Poly graciously provided academic release time for the PI, as well as a stipend to support the visiting scholar from NJUT. Prof. Zhihua Wang of NJUT is thanked for his hard work and patients in performing the non-linear analysis. NJUT graciously provided the sabbatical expenses for the duration of his visiting scholar stint at Cal Poly.

REFERENCES

Bazzurro, P., and Cornell, C. A. (2004). "Ground-Motion Amplification in Nonlinear Soil Site with Uncertain Properties." *Bulletin of Seismological Society of America*, 94(6), 2090-1019.

Crosariol, V. (2010) . "Scale Model Shake Table Testing of Underground Structures in Soft Clay." Master's Thesis, Cal Poly San Luis Obispo.

Hashash, Y. M. A., Hook, J. J., Schmidt, B., and Yao, J. I.-C. (2001). "Seismic design and analysis of underground structures." *Tunnelling and Underground Space Technology*, 125.

Hudson, M.B., Beikae, M., and Idriss, I.M. (1994). "QUAD4M, a Computer Program to Evaluate the Seismic Response of Soil Structures Using Finite Element Procedures and Incorporating a Compliant Base." Center for Geotechnical Modeling, U.C. Davis, 1994-05.

Idriss, I.M., and Sun, J.I. (1992) "User's Manual for SHAKE91: A computer program for conducting equivalent linear seismic response analysis of horizontally layered soil deposits." Center for Geotechnical Modeling, U.C. Davis.

Lysmer, J., Udaka, T., Tsai, C-F., Seed, H.B. (1975)

"FLUSH: a computer program for approximate 3-D analysis of soil-structure interaction problems." UCB/EERC-75/30, Earthquake Engineering Research Center, University of California, Berkeley, 1975-11, 139 pages (555.6/L92/1975)

Meymand, P. J. (1998). "Shaking Table Scale Model Tests of Nonlinear Soil-Pile-Superstructure Interaction in Soft Clay," Ph.D. Dissertation, Civil and Environmental Engineering Department, U.C. Berkeley. Simulia (2009) Providence R.I., http://www.simulia.com/products/abaqus_standard.html.

Stewart, J. P., Seed, H. B., and Fenves, G. L. (1999). "Seismic Soil-Structure Interaction in Buildings. II: Empirical Findings." *Journal of Geotechnical and Geoenvironmental Engineering*, 121(1).