

## SHAPE AND DEFORMATION MEASUREMENT USING HETERODYNE RANGE IMAGING TECHNOLOGY

Richard Conroy<sup>1</sup>, Adrian Dorrington, Michael Cree, Rainer Künnemeyer, Brian Gabbitas

Department of Engineering, University of Waikato,  
Private Bag 3105, Hamilton, New Zealand

### Abstract

Range imaging is emerging as a promising alternative technology for applications that require non-contact visual inspection of object deformation and shape. Previously, we presented a solid-state full-field heterodyne range imaging device capable of capturing three-dimensional images with sub-millimetre range resolution. Using a heterodyne indirect time-of-flight configuration, this system simultaneously measures distance (and intensity), for each pixel in a camera's field of view. In this paper we briefly describe our range imaging system, and its principle of operation. By performing measurements on several metal objects, we demonstrate the potential capabilities of this technology for surface profiling and deformation measurement. In addition to verifying system performance, the reported examples highlight some important system limitations. With these in mind we subsequently discuss the further developments required to enable the use of this device as a robust and practical tool in non-destructive testing and measurement applications.

### 1. Introduction

Numerous applications exist that lend themselves to fast, accurate, and robust non-contact surface profiling and deformation measurement. Some examples include, quality control on production lines, determining wear and tear on equipment, and measuring deflection in standard bend tests. Many surface profiling measurement schemes have been proposed and developed and a number of optical techniques exist for visual inspection of metallic surfaces [1–5]. One particular solution measures the profile of a metal surface through Kirchoff diffraction theory analysis of the reflected light intensity distribution [2]. Other research combines traditional intensity imaging with triangulation based depth imaging for a more complete visual defect analysis of metallic surfaces [3]. Optical non-contact measurement of deformation across a full field of view offers many advantages over traditional methods such as those which use strain gauges or accelerometers. Such methods are often difficult to set up, require specialist equipment, add mass to the system and cannot achieve 100 % coverage.

Solid-state full-field three-dimensional (range) imaging technologies have been the subject of considerable research efforts in recent times. Modern range imaging systems are capable of measuring the distance to every pixel in an image simultaneously, offering the possibility of real-time three-dimensional image acquisition.

Until recently, the range resolution benchmark for these devices was on the centimetre scale, which precluded their use in applications requiring measurement of fine surface detail. Recent efforts at the University of Waikato have led to the development of a unique range imaging system achieving a single sigma ranging precision of 400  $\mu\text{m}$  under optimal conditions [6]. This system determines range by indirectly measuring the time-of-flight of light simultaneously for every pixel in an image using an intensity modulated heterodyne imaging method. Unlike most solid-state systems that use a homodyne configuration, a heterodyne imaging approach has been adopted to achieve this unprecedented ranging precision (for a full-field ranging device) [7].

The system presented offers a practical solution to a variety of problems with 100 % measurement coverage of the visible surface in the field of view. Range imaging is emerging as a promising alternative method in applications that require accurate measurement of object deformation and shape. As well as providing a precise three-dimensional image, an added advantage of our configuration is the simultaneous capture of intensity data allowing further defect analysis by augmenting traditional intensity based methods.

Through quantitative and qualitative measurement examples, we present our range imager as a potential tool for non-destructive testing (NDT) and measurement applications. These examples include:

---

<sup>1</sup> [rmc21@waikato.ac.nz](mailto:rmc21@waikato.ac.nz)

- Measuring the deflection of a metal plate under load to demonstrate the systems potential use as an accurate non-contact deformation measurement device, and
- Capturing range images of various metal objects to display the systems potential for surface profiling and shape measurement.

In this paper we firstly present our range imaging system, and the principles behind time-of-flight distance measurement and heterodyne imaging. By way of example we report on some of the potential capabilities of our ranger for NDT and surface profiling with a particular emphasis on shape and deformation measurement of metal objects and structures. We also review the limitations of the system and the ongoing development work to overcome these drawbacks and move towards a handheld commercial testing device.

## 2. Background

### 2.1. Range measurement technique

The ability to accurately measure distance using optical methods is a widely researched and well developed field. Considerable effort has been directed towards developing optimal systems using a variety of optical methods and techniques. These methods include laser scanning using single point range finders; triangulation based systems employing either a stereo vision or structured illumination approach; and imaging lidar techniques which either directly or indirectly measure the time light takes to travel to an object and back (time-of-flight). A more detailed explanation and review of these methods can be found in Dorrington *et al.* [7].

Various imaging lidar techniques have been proposed, and most indirect time-of-flight methods utilise very similar configurations. Such systems generally consist of an active intensity modulated illumination source and a high-speed (non-mechanical) shutter placed in front of a camera used to collect the backscattered illumination. Imaging lidar systems rely on the constant known velocity of light, and indirectly measure distance by determining the small amount of time it takes for light to travel to the object and back to the camera. By measuring this propagation delay, distance is found using the simple relationship

$$d = \frac{t c}{2} \quad (1)$$

where  $d$  is the distance to the object,  $\tau$  the time of flight and  $c$  the speed of light. The simplest approach is to transmit a pulse of light and time its propagation delay. Unfortunately, accurate measurement with this “direct” approach can be problematic due to the speed limitations of current electronic technology. To overcome these restrictions, modulation of the illumination intensity with a continuous waveform (typically at 10–100 MHz) is used. In this case, the modulation envelope of the reflected light signal arriving back at the camera is shifted in phase due to the propagation delay. Practically, this phase change is much less difficult to measure yet can still be used to calculate range using equation 2 where  $f$  is the modulation frequency and  $\phi$  the phase delay.

$$d = \frac{j c}{4 p f} \quad (2)$$

Previous imaging lidar systems have used pulsed or homodyne arrangements [7]; however the range imaging system developed at the University of Waikato employs a unique heterodyne configuration. This arrangement also uses continuous wave modulation (10–100 MHz), but unlike typical homodyne systems, the illumination source and the shutter are driven at slightly different frequencies [8]. This mode of operation causes a mixing effect at the shutter between the reflected modulated light signal and the shuttering operation producing a low frequency beat signal (typically of a few Hz).

In homodyne systems where the illumination and shutter frequencies are identical, the phase change experienced due to the propagation delay of light is encoded as a constant brightness level. Unfortunately several other factors (such as object colour, texture, and background lighting) also influence image brightness and interfere with the distance measurement [7].

With a heterodyne configuration, the phase change of the propagated illumination waveform is preserved in the beat signal and is found through analysis of the time varying intensities of this low frequency beat. This concept can easily be observed in a captured video sequence where objects in a scene flash on and off at different times depending on how far away they are from the camera. Because the analysis of beat signal phase is independent of absolute or average intensities, the undesirable effects of object colour, texture, and background lighting on range determination are significantly reduced [7].

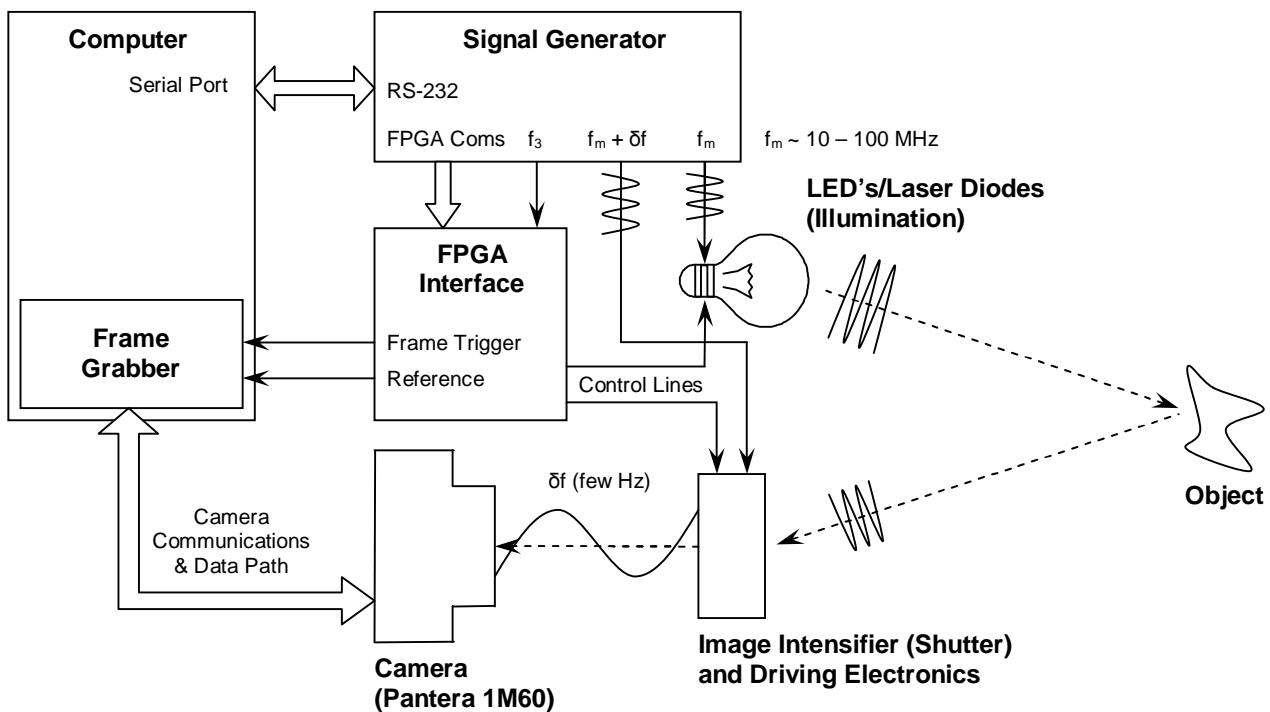

Figure 1: Block diagram of current range imaging hardware including signal and dataflow.

## 2.2. Hardware configuration and system performance

A block diagram of the current range imager hardware is shown in figure 1. The image acquisition is performed with a Pantera 1M60 digital video camera (Dalsa Corporation, Ontario, Canada) and a frame-grabber. Illumination is provided by either an array of 658 nm laser diodes, or a bank of red, green, or blue LED's. Like many other imaging lidar arrangements this system employs an image intensifier (Photek Ltd, East Sussex, UK) as the high speed shutter. Other hardware include the driver circuit associated with the intensifier; a specialised frequency locked signal generator to provide the illumination and shutter modulation signals, and the camera frame trigger; and also some interface electronics using a Xilinx Field Programmable Gate array (FPGA). For further detail of the hardware configurations see references [7–9].

One-sigma ( $1-\sigma$ ) precision values of  $600\ \mu\text{m}$  have been demonstrated using a modulation frequency of 65 MHz and a beat frequency of 1 Hz [7]. Recent enhancements in the intensifier drive electronics have enabled faster operation with modulation frequencies as high as 85 MHz improving precision to  $400\ \mu\text{m}$  [6].

In order to suit different applications, most system parameters such as acquisition time, frame rate, and beat frequency, can be configured in software. In testing to date, peak performance has been

achieved with 10 second acquisitions; however faster acquisitions can be performed to the detriment of measurement precision. Acquisition times of around 0.1 s have been demonstrated with an associated degradation of precision.

One of the consequences of homodyne and heterodyne range imaging systems is the phase ambiguity due to the cyclic modulation signal. A single phase change value measured by these systems can represent a number of possible distances separated by multiples of a half wavelength of the modulation signal. For the presented system, this issue can be resolved by taking two captures with different modulation frequencies and post processing the data; although with hardware upgrades there is potential to perform the corrections with a single measurement [6].

## 2.3. Potential for NDT, deformation measurement and surface profiling

Accurate acquisition of three dimensional images would benefit a variety of industries and research areas; for example, quantitative and qualitative non-destructive testing and measurement using range imaging technology could potentially serve numerous applications. With current precision levels, measurements of fine, micron sized cracks and defects are not possible. But as a versatile tool for detecting and measuring features of millimetric proportions, the presented range imaging technology has significant potential.

An important characteristic of this system is its versatility in different measurement situations. Lens and illumination systems can easily be custom designed to suit specific applications from measuring small objects to large structures. If optical power was not a restriction, a larger application example would be the measurement of bridge movement under dynamic load. Another large scale application would be robust non-contact measurements of structural integrity of buildings or other sizeable structures.

A more practical near-term application is the measurement of shape and surface profile as a quality assurance and control tool in NDT applications. Although not developed yet, by knitting together multiple range images from different angles, a full three-dimensional profile of an object can be acquired. These profiles could then be compared to CAD models for verification of shape and dimensions. On a production line, automated quality control could be implemented using an image ranging system to find and discard products which do not meet specifications.

Another area of NDT where an accurate range imager would be useful is in the measurement of device behaviour under load. For example, the deflection of a beam could be measured for stress analysis when subjected to a certain load. A simulated measurement example of such a test follows below. Further applications could include the dynamic analysis of the deformation of a pressure vessel, structural integrity examinations of a vehicle's axle/chassis system, through to measuring the movements of an aircraft shell while airborne. Non-contact actual behavioural analysis would provide significant advantages over other methods allowing comparison with, and verification of, predicted CAD models.

With miniaturisation and improvements to system performance, another potential application area is wear and tear measurement and preventative maintenance, such as inspection of gear boxes, and the measurement of shaft deformation. As an inspection tool, range imaging technology could be used in control systems for automated preventative maintenance.

### 3. Measurement examples

#### 3.1. Deflection of a metal plate

##### 3.1.1. Experimental setup

We demonstrate the potential of our system for shape and deformation measurement by a simple laboratory measurement example. In this

investigation we measure the deflection of a 2 mm thick steel plate (width 100 mm, length 280 mm) when “fixed” at both ends and placed under load through its (approximate) centre. For the purposes of this experiment and for reasons outlined later, this plate was bead blasted and spray painted a flat white colour to reduce specular reflections and ensure consistent surface texture and colour (discussed below). Figure 2 shows the simple experimental setup used. A rigid steel frame was constructed to hold the plate, and an M6 bolt was tapped through the back of the frame to push the plate outwards from the rear as shown in the photograph.



Figure 2: *Photograph of experimental setup.*

We then proceeded to capture range images of the plate at various levels of deflection by successively turning the bolt (by hand) in steps of two full revolutions. Starting from a position of “zero-deflection” (flat plate), the bolt was turned through 10 complete revolutions, i.e. a total of six measurements. Performing the measurements in regular steps ensured the actual plate displacement between adjacent measurements would remain reasonably consistent. The range images here and throughout this paper were captured with a 78 MHz modulation frequency, 1 Hz beat frequency, 29 Hz camera frame rate, and an acquisition time of 10 s (10 beat cycles).

Unfortunately an accurate reference measurement of the actual deflection could not be carried out with the equipment available. However with a crude measurement of the thread pitch of the bolt, it was determined that two revolutions corresponds to a deflection of approximately 1.9 mm. Although care was taken to ensure the revolutions were completed as precisely as possible, there still remains a high degree of uncertainty in this value.

### 3.1.2. Results

In order to examine the measured deflection of the metal plate, a vertical cross-section of the measured surface profile through a point of maximum deflection was analysed for each range image. Results of the experiment are shown in figure 3. This cross-sectional plot shows the deflection as measured by our range imager from the non distorted position (0 mm deflection) through to the maximum deflection of 10 bolt revolutions, or 9.5 mm. Considering the measurement uncertainties, the results obtained are excellent and verify that each measurement was separated consistently at the maxima by the expected amount of about 1.9 mm. Not only do these results provide a qualitative system demonstration but also a rough quantitative verification of the system's measurement performance.

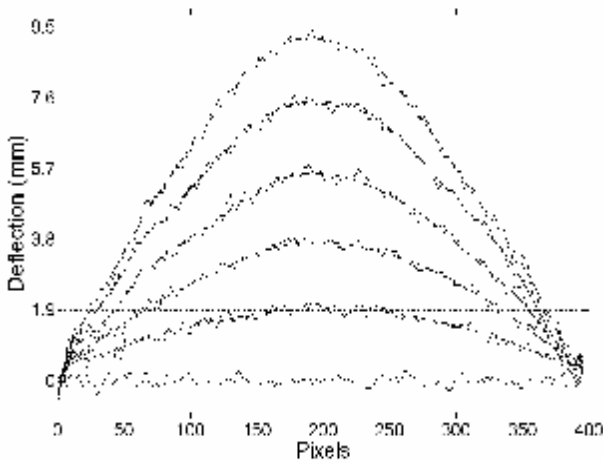

Figure 3: *Deflection measurement results.*

Although not displayed, the cumulative effects of many system distortions were noticeably evident in the raw results, and were manifested as:

- An apparent  $\sim 20$  mm deflection for the undistorted plate, and
- Small absolute range offsets between different measurements.

The major contributor to these distortions is the use of simplistic parallel projection of the range data, rather than the more appropriate perspective projection. In addition measurement inaccuracies/ variations include the lens and iris distortions, and geometric distortions. Analysis and calibration of these distortions is beyond the scope of this paper, but in order to display only the deflection effects, some simple processing was performed to remove

the distortions by referencing to the initial measurement where the plate was known to be flat. The small variations in absolute range were removed using a least squares minimisation and adding a constant. A twelfth order polynomial was then used to find the first “zero-deflection” measurement. By subtracting this polynomial from all of the six subsequent datasets, the measurement distortions were removed to some degree leaving only the measured deflection and random noise. Twelfth order polynomials were then fitted to each measurement as is shown in figure 3.

For all of these measurements the vertical cross-sectional deflection values were obtained from an average of 25 horizontally adjacent range values across the region of interest, improving the range data precision by a factor of 5 compared to a single column of values. Therefore, with no obvious defects on the relatively flat metal surface being measured, and given the satisfactory polynomial fit, the single sigma precision value of these measurements was found to be 120  $\mu\text{m}$ .

### 3.2. Other examples

In order to further qualitatively demonstrate the systems capabilities we present two additional measurement examples. A steel block with a height of 100 mm and width of 70 mm was measured as the first example, and is shown in figure 4 (a). The second example is a range image of a wheel with diameter 175 mm (figure 4 (b)). Ideal testing conditions were again used by painting both objects a flat white colour.

For each example we have displayed both a standard photograph of the object (left) and a reconstruction of the captured range image (right). The range imager simultaneously captures range and intensity information, but the intensity is omitted here for clarity. These were rendered in Matlab using a surface plot and a virtual light source to visibly show the measured 3-D data.

These plots demonstrate the accurate three-dimensional shape measurement capabilities of our system. Details such as the 2 mm high ridges on each spoke of the wheel, and the sharp edges of the block are clearly evident. Unfortunately the chosen rendering accentuates the measurement noise; although based on previous experiments under the same operating conditions, it is reasonable to suggest the  $1\text{-}\sigma$  precision level of these measurements is close to 400  $\mu\text{m}$ .

#### 4. Discussion

The results and examples shown clearly illustrate the potential for our range imaging system to be employed as a tool for non-contact measurement of object shape and deformation. In the first example we simulated a typical bend test by accurately measuring the deflection of a metal plate under load. Through this simple test, a number of potential measurement applications are covered, and the results obtained demonstrate the high precision exhibited by the technology. Furthermore, the surface profiling and shape measurement capabilities of our system were visibly depicted with the final two examples.

We reinforce that this technology is in its relative infancy, and in order to be useful as an NDT device a number of system limitations need to be overcome. One of these is the lack of calibration for various measurement distortions. In addition to the normal lens distortions common in the literature, there are also geometric distortions. These geometric distortions arise due to the relative placement of the light source and the camera, and because the illumination cannot be perfectly collinear with the imaging axis. Research is currently underway to calibrate the system for these types of distortion.

A further issue which needs to be resolved is the small indirect dependency of object colour on range determination. An ideal system will measure range completely independently of absolute intensities; however in its current form, measuring a flat surface with inconsistent colour will not produce a perfectly flat range image. It is for this reason that in the measurement examples, the objects being tested were painted a uniform colour

In terms of object texture, specular reflection can contaminate range data. This is a particular problem when measuring metals, or objects with glossy surfaces. Covering the observed surfaces with paint that has a flat finish can reduce these effects; and indeed this was the technique adopted in the presented examples. Alternatively objects that exhibit specular reflection can be measured at angles that direct the reflection away from the imaging axis; however this can become problematic for measurements of curved surfaces. As part of ongoing developments, a more robust solution using polarised light is to be investigated.

Finally, a number of drawbacks are associated with using image intensifiers to perform the required high speed shuttering such as large size and high power consumption. In the future, these limitations will be addressed by integrating the high speed

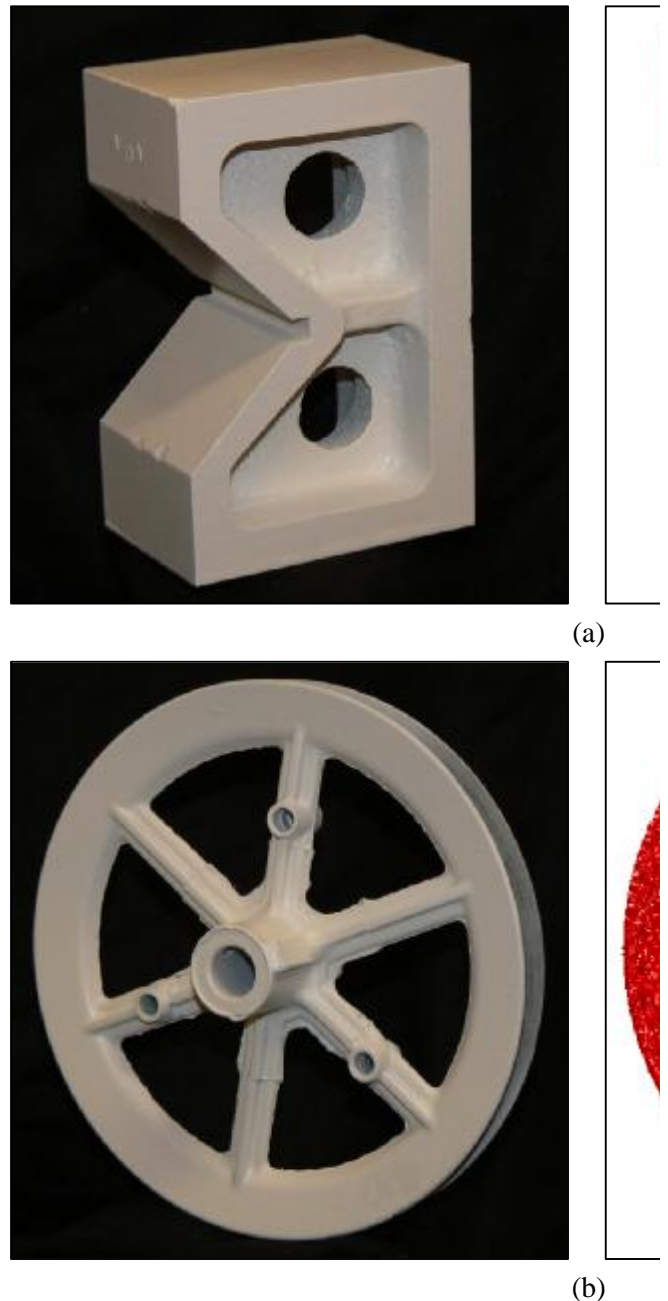

Figure 4: Photographs (left) and reconstructed range images (right) of (a) a steel block; and (b) a wheel.

shuttering onto an image sensor, a development which is currently in progress. The long term goal is to produce a handheld heterodyne range imaging device with performance better than that currently being achieved.

#### 5. Conclusion

A high-precision full-field heterodyne range imaging system has been developed at the University of Waikato. Through several basic measurement examples we have evaluated this technology and its potential capabilities in relation to shape and deformation measurement of objects and structures. A quantitative deflection test has

demonstrated the system measurement performance and application potential. We conclude that although considerable further development is required, the presented technology has significant potential to serve in a wide variety of non-contact measurement applications.

## 6. References

- [1] Hu, L., Duan, F., Ding, K. and Ye, S., “Design of optical system for surface defect detection of steel strip,” *Chin. J. Sens. Actuators (China)*, vol. 18, pp 726–732, 2005.
- [2] Nie, C., Miyoshi, T., Takaya, Y., Takahashi, S. and Yanada, K., “Development of optical ring image sensor for 3D profile measurement of machined metal surface. Light scattering simulation of metal surface and its verification,” *J. Jpn. Soc. Precis. Eng. (Japan)*, vol. 65, pp. 1668–1673, 1999.
- [3] Pernkopf, F. and O’Leary, P., “Image acquisition techniques for automatic visual inspection of metallic surfaces,” *NDT&E Int. (UK)*, vol. 36, pp. 609–617, 2003.
- [4] Someji, T., Sasaki, M., Yoshida, M. and Akiyama, N., “Study of optical measuring method for surface roughness of cast metals,” *J. Jpn. Soc. Precis. Eng. (Japan)*, vol. 64, pp. 231–235, 1998.
- [5] Yang, X., Qiu, Z., Yu, C. and Jin, G., “Study on laser shape measurement system for hot-rolling strip steel,” *Proc. 37<sup>th</sup> SICE Annual Conference*, Chiba, Japan, pp. 911–914, 1998.
- [6] Dorrington, A. A., Cree, M. J., Carnegie, D. A., Payne, A. D. and Conroy, R. M., “Heterodyne range imaging as an alternative to photogrammetry,” *Videometrics IX, part of the IS&T/SPIE Symposium on Electronic Imaging*, San Jose, California, USA, 2007, Abstract Submitted.
- [7] Dorrington, A. A., Carnegie, D. A. and Cree, M. J., “Toward 1-mm depth precision with a solid state full-field range imaging system,” *Proc. SPIE, Vol. 6068 – Sensors, Cameras, and Systems for Scientific/Industrial Applications VIII, part of the IS&T/SPIE Symposium on Electronic Imaging*, San Jose, CA, USA, pp. 60680K1–60680K10, 2006.
- [8] Carnegie, D. A., Cree, M. J. and Dorrington, A. A., “A high-resolution full-field range imaging system,” *Rev. Sci. Instrum. (USA)*, vol. 76, 083702, 2005.
- [9] Payne, A. D., Carnegie, D. A., Dorrington, A. A. and Cree, M. J., “Full field image ranger hardware,” *Third IEEE International Workshop on Electronic Design, Test and Applications*, Kuala Lumpur, Malaysia, pp. 263–268, 2006.