

**NASA  
Technical  
Paper  
2711**

April 1987

# Shot Peening for Ti-6Al-4V Alloy Compressor Blades

Gerald A. Carek

**NASA**

**NASA  
Technical  
Paper  
2711**

1987

# Shot Peening for Ti-6Al-4V Alloy Compressor Blades

Gerald A. Carek

*Lewis Research Center  
Cleveland, Ohio*

**NASA**

National Aeronautics  
and Space Administration

Scientific and Technical  
Information Branch

## Summary

A test program was conducted to determine the effects of certain shot-peening parameters on the fatigue life of the alloy Ti-6Al-4V as well as the effect of a demarcation line on a test specimen. This demarcation line, marking the abrupt change from untreated surface to shot-peened surface, was thought to have caused the failure of several blades in a multistage compressor at the NASA Lewis Research Center. The demarcation line had no detrimental effect on bending fatigue specimens tested at room temperature. Procedures for shot peening Ti-6Al-4V compressor blades are recommended for future applications.

## Introduction

Several blades in a multistage compressor at the NASA Lewis Research Center failed. Cracks developed in the airfoil section of the Ti-6Al-4V blades just above the root fillet. The root fillet, which is between the airfoil and the platform, was shot peened, but the airfoil surface was masked off. This caused an abrupt demarcation line between the shot-peened fillet and the unpeened airfoil. Although the cracks in these blades occurred very close to this demarcation line, it was not known precisely what effect the line had on the failures. A test program was conducted to determine this and also to evaluate the application and potential benefits of shot peening to Ti-6Al-4V compressor blades. Various shot-peening intensities and types of shot were used. This report describes the shot-peening process used and the tests conducted and presents the results of these tests and the conclusions drawn from the results. This report also recommends a shot-peening procedure for Ti-6Al-4V compressor blades.

## Shot-Peening Process

It has been known for some time that shot peening can extend the fatigue life of a material (ref. 1). Other beneficial effects include the prevention of fretting and stress corrosion cracking (refs. 1 and 2). Shot peening induces a high compressive stress in the surface of a material by bombarding it with small steel or glass shot. These compressive stresses are balanced by a slight tensile stress in the center of the cross section (fig. 1). The superposition of applied bending stress and residual stress

shows the decrease in surface tensile stress (fig. 2). Fatigue life is extended because the high compressive stresses in the surface layer prevent formation of surface cracks. Previous research on Ti-6Al-4V shows that fatigue behavior after shot peening is primarily determined by these residual compressive stresses (refs. 3 and 4).

Many factors (such as intensity levels, coverage, type and size of shot, and surface finish) must be considered when shot peening a material. Intensity is a measure of shot-peening severity. It is measured by using Almen test strips. The test strips, which are rectangular metal strips in three different thicknesses and are shot peened on one side only, curve convexly on the peened side. The height of the curved arc in inches is the measure of intensity. The three thicknesses of the strips are designated by N, A, or C. The N strips are the thinnest and are used to measure the lower intensity levels; the C strips are the thickest and measure the higher intensity levels. It has been found that overpeening a material (shot peening at an intensity level higher than desired) shortens fatigue life (refs. 5 and 6).

## Specimen Description

The fatigue tests were performed with bending specimens. The specimens were fabricated from annealed Ti-6Al-4V alloy plate, 2.95 mm (0.116 in.) thick. This represents the typical airfoil thickness at the critical stress point in scaled compressor blades tested at Lewis. The test area was approximately 76 mm (3 in.) long and was tapered in width to experience constant bending stress (fig. 3). The specimens for this test were all shot peened at 200 percent coverage to ensure that the peened area was completely impacted by shot. The alternative would have been shot peening at 100 percent coverage and then using a dye penetrant inspection to determine whether coverage was complete.

Two groups of Ti-6Al-4V specimens were used for the program. Each specimen in the first group had one half of the test section masked off to produce a sharp transverse demarcation line between the peened and unpeened surfaces (fig. 3). This group was used to determine if a demarcation line has any detrimental effects. Four of the nine specimens in this group were shot peened with stainless steel shot to an intensity level of 0.010 to 0.012 A with 200 percent coverage. The other five specimens were shot peened with glass bead shot to an intensity level of 0.008 to 0.010 N with 200 percent

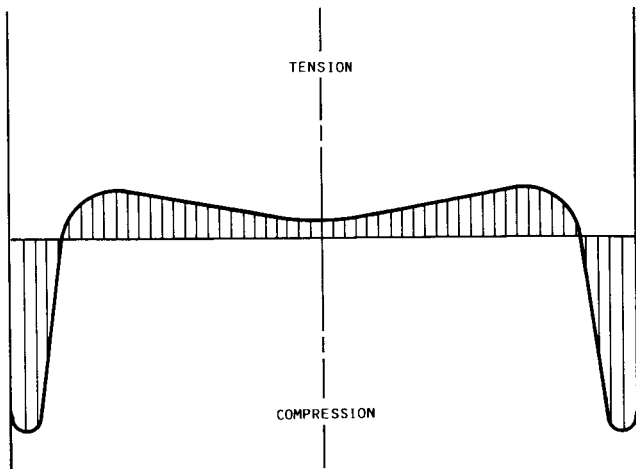

Figure 1.—Typical residual stress distribution after peening.

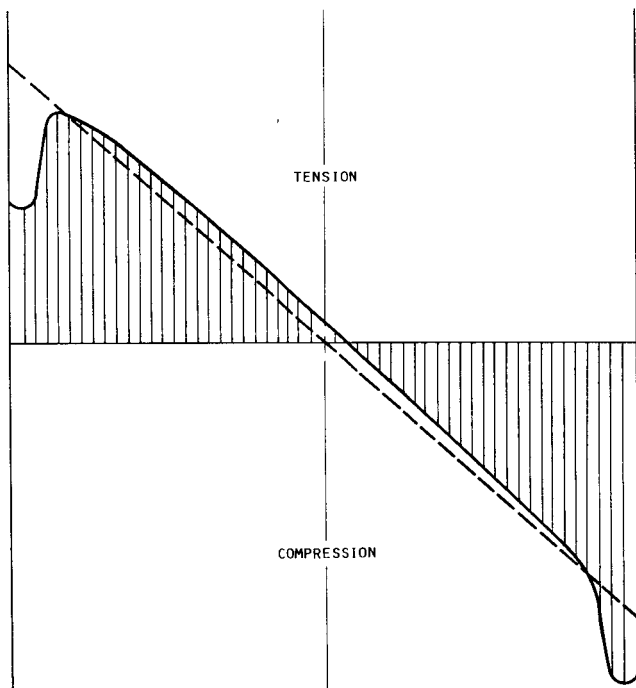

Figure 2.—Superposition of applied bending and residual stress.

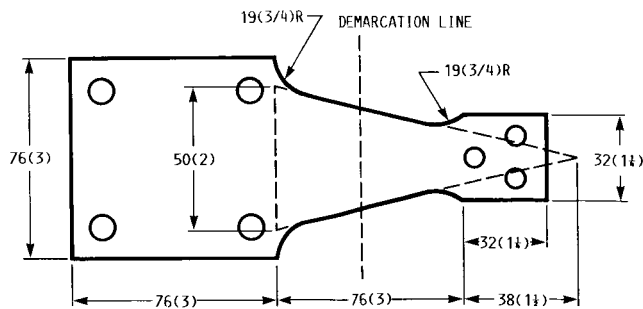

Figure 3.—Dimensions of fatigue specimen. (Dimensions are in millimeters (inches)).

coverage. The shot-peened area on each specimen covered approximately half of the constant-stress area. Detrimental effects of the demarcation line would be evident if fatigue cracks were to form at this interface of peened to unpeened surface.

Each specimen in the second group was shot peened on its entire surface. This group of 18 specimens was divided into four sets. Each set was subjected to a different shot-peening method. This group was used to determine the effect of shot-peening intensity and shot material (table I) in extending fatigue life. One of the shot-peening methods is a two-step process. The specimen is first shot peened using the parameters of step 1 (table I) and then shot peened again using the parameters of step 2. This two-step method was obtained from documentation on previous testing of Ti-6Al-4V (ref. 3). The second step of this process not only contributes to the residual compressive stress layer, but also serves as a cleaning and smoothing operation.

## Test Procedure

A specimen loaded in the fatigue bending machine is shown in figures 4 and 5. The machine that performed the fatigue tests could apply bending loads only. The tip of the specimen was clamped in a split fixture that in turn was attached to a connecting rod which was driven by an adjustable rotating eccentric. During operation the tip of the specimen was alternately pushed up and pulled down through an equal displacement amplitude. This amplitude, which could be adjusted, determined the alternating stress on the specimen. A NASTRAN finite element analysis was performed to determine the correlation between the amplitude and the alternating stress level. This was experimentally verified by using a strain-gauged specimen. The measured and calculated stress levels agreed within 5 percent.

The fatigue life for annealed Ti-6Al-4V alloy is about 517 MPa (75 000 psi) based on  $10^7$  cycles with smooth, rotating beam specimens. Since many factors (such as surface finish, size effects, and stress concentrations) shorten the fatigue life for the bending specimens used in this test, an alternating stress level of 482 MPa (70 000 psi) was chosen.

TABLE I.—SHOT-PEENING PARAMETERS FOR SPECIMENS IN SECOND TEST GROUP

Set	Intensity	Shot material	Number of specimens
1	0.008-0.010 N	Stainless steel	3
2	0.006-0.008 A		5
3	0.010-0.012 A	Glass	5
4	<sup>a</sup> 0.010-0.012 A <sup>b</sup> 0.008-0.010 N		5

<sup>a</sup>Step 1.

<sup>b</sup>Step 2.

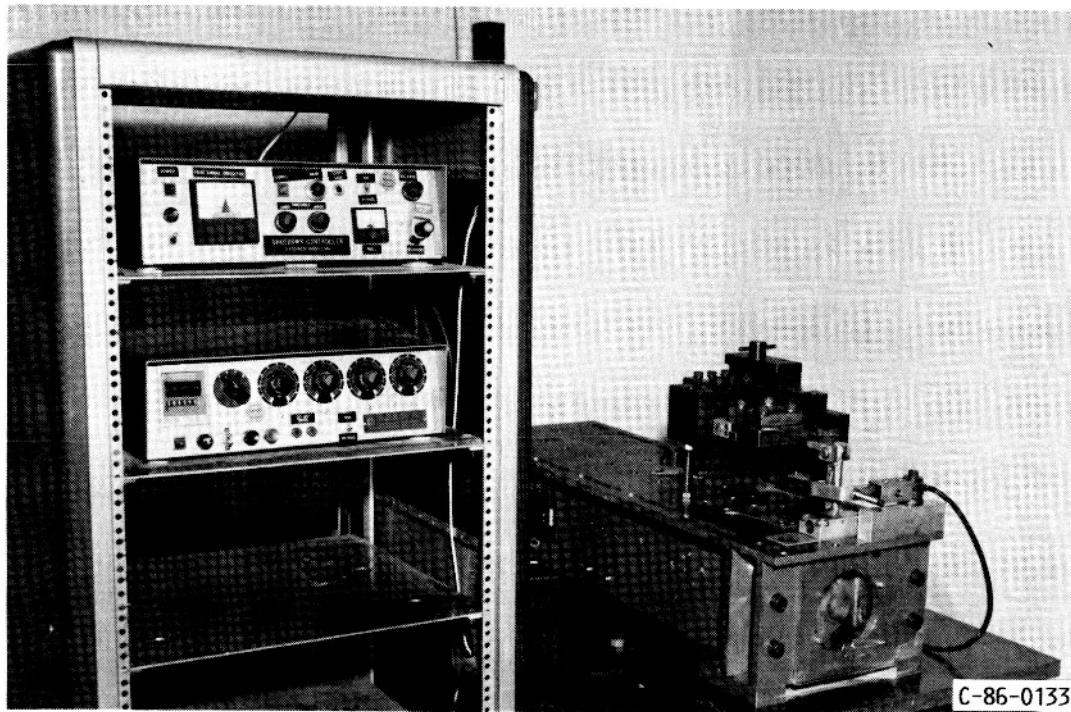

Figure 4.—Fatigue test rig.

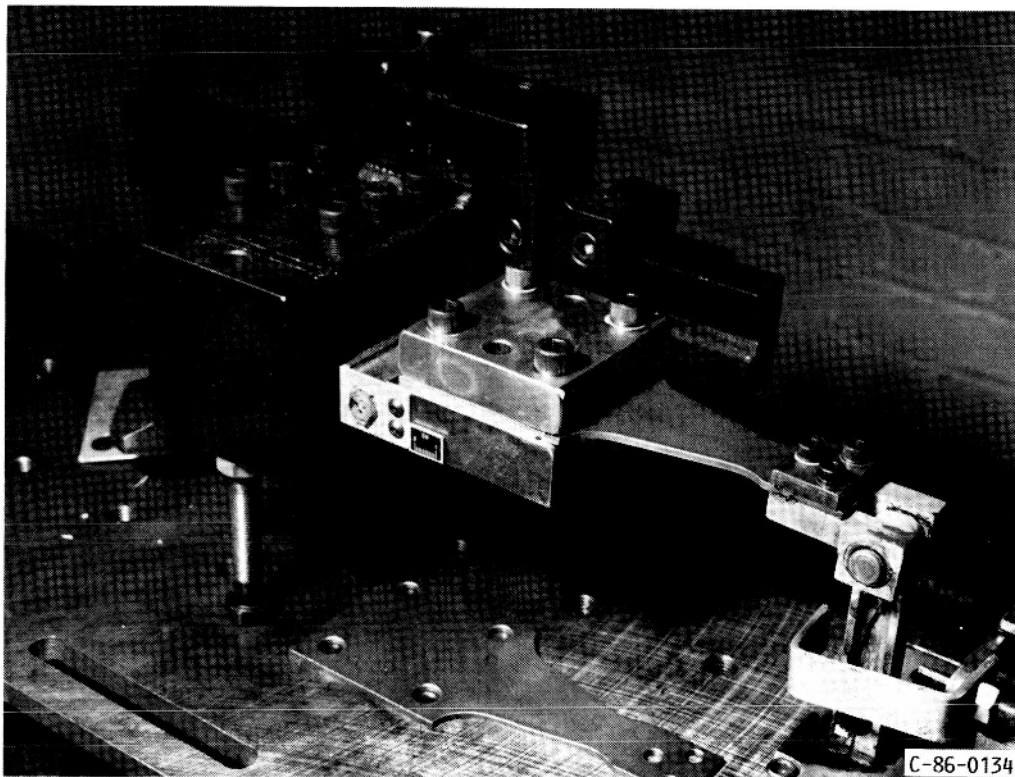

Figure 5.—Fatigue specimen mounted in test rig.

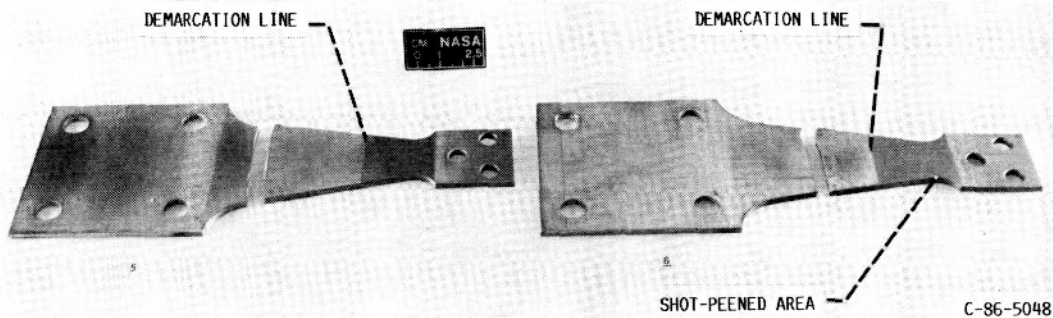

Figure 6.—Typical failed fatigue specimens.

## Discussion of Results

All test specimens in the first group (masked specimens) failed in the area that was not shot peened, well away from the demarcation line. Two typical failures can be seen in figure 6. Therefore it was determined that the demarcation line is not a preferential site for crack initiation. The cracking of the blades in the Lewis multistage compressor can now be attributed to high alternating tensile stress levels only. The cracks in these blades were located on the airfoil near the root fillet, which is between the airfoil and the platform. This is the location at which the bending tensile stress on the airfoil is highest. Since the shot-peened area was limited to the platform and fillet, the airfoil did not have the fatigue advantage that results from shot peening. It is estimated that extending the shot-peened area to about 20 percent of the airfoil

span could extend the fatigue life by a factor of 3 or more. Aerodynamic losses can be minimized by lightly polishing the shot-peened area of the airfoil.

Tests on the second group of specimens revealed that fatigue life can be considerably lengthened by increasing the shot-peening intensity (table II). Increasing the intensity from 0.008–0.010 N to 0.010–0.012 A, using stainless steel shot, increased the cycles to failure from  $7.1 \times 10^6$  to  $11.1 \times 10^6$  (55 percent increase). A two-step process using 0.010–0.012 A (with stainless steel shot) as the first step followed by 0.008–0.010 N (with glass shot) gave  $18.7 \times 10^6$  cycles to failure (130 percent increase over the base level 0.008–0.010 N process ( $7.1 \times 10^6$  cycles)). The compressive stress layer produced from shot peening at the 0.010–0.012 A intensity level was about 0.229 mm (0.009 in.) deep. This layer should be no more than 10 percent of the thickness; otherwise harmful tensile stresses that could decrease the fatigue life will build up in the center of the cross section. For this reason intensity levels greater than 0.010–0.012 A were not used. A typical airfoil usually has very thin leading and trailing edges that would require a lower intensity level. To obtain the full benefits from shot peening, the intensity should be varied from thick to thin cross sections.

TABLE II.—FATIGUE LIFE OF Ti-6Al-4V ALLOY SUBJECTED TO FOUR SHOT-PEENING METHODS

[Alternating stress, 482 MPa (70 000 psi).]

Method	Intensity	Shot material	Number of cycles to failure	Average number of cycles to failure
1	0.008–0.010 N	Stainless steel	8 536 900	7 085 000
			6 947 000	
			5 771 600	
2	0.006–0.008 A	↓	7 519 800	8 953 000
			4 984 800	
			13 496 900	
			10 444 100	
			8 319 800	
3	0.010–0.012 A	↓	5 571 900	11 162 600
			1 229 000	
			15 214 000	
			18 172 000	
			15 626 300	
4	<sup>a</sup> 0.010–0.012 A	Glass	11 359 100	18 782 800
			<sup>b</sup> 0.008–0.010 N	
	16 252 380			
	21 744 600			
			16 251 000	

<sup>a</sup>Step 1.

<sup>b</sup>Step 2.

## Concluding Remarks

The application of shot peening to Ti-6Al-4V compressor blades at the NASA Lewis Research Center has not taken full advantage of its benefits to extend fatigue life. These tests have shown that the shot-peening parameters that were used should be modified.

The following guidelines should be used when specifying shot-peening parameters for Ti-6Al-4V components:

1. For a cross section with a minimum thickness of at least 2.29 mm (0.090 in.), shot peen per MIL-S-13165B in two steps:

a. Shot peen to an intensity of 0.008–0.010 A and 100 percent coverage using MI-110 stainless steel conditioned shot. (The 0.010–0.012 A parameter that was used on the test specimens was lowered to 0.008–0.010 A as a safety factor

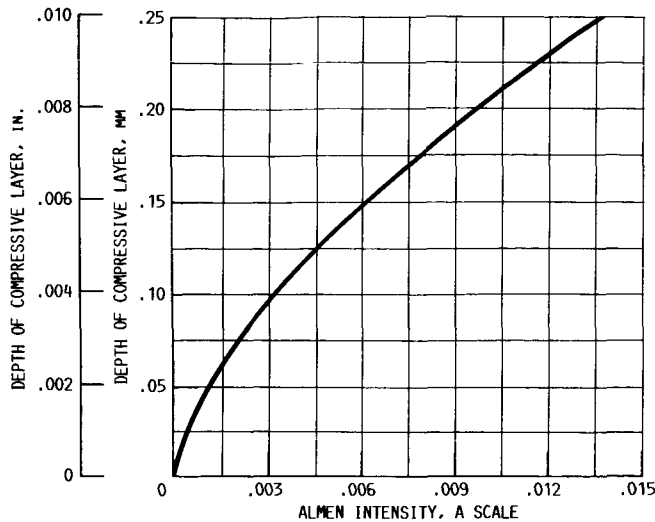
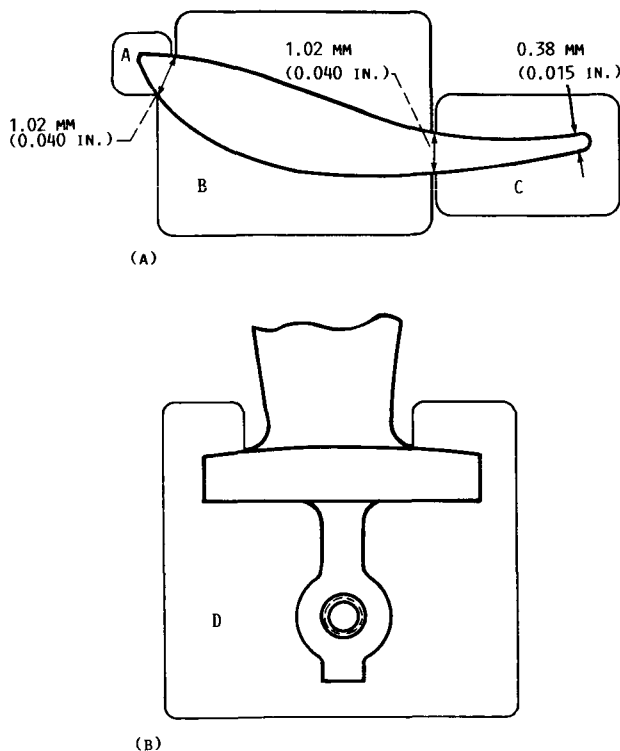

Figure 7.—Depth of compressive stress as function of Almen intensity for Ti-6Al-4V. (From ref. 1.)



- (a) Shot peen area B with two-step process: (1) 0.008–0.010 A at center with linear decrease of intensity to 0.002–0.004 A at ends of area (stainless steel shot); (2) 0.008–0.010 N (glass bead shot). Shot peen areas A and C to 0.008–0.010 N (glass bead shot). Shot peen root fillet and 20 percent of airfoil span (areas A, B, and C).
- (b) Shot peen entire area D with two-step process: (1) 0.008–0.010 A (stainless steel shot). (2) 0.008–0.010 N (glass bead shot).

Figure 8.—Detailed procedure for shot peening compressor blades.

to prevent excessive tensile stresses in the center of the cross section.)

b. Shot peen to an intensity of 0.008–0.010 N and 100 percent coverage using GP25 glass bead shot.

2. For a cross section between 2.29 and 1.02 mm (0.090 and 0.040 in.) thick a lower intensity level should be used for the first step in the two-step process. The compressive layer produced on each surface of the component should be no more than 10 percent of the minimum cross-sectional thickness. To determine the intensity level, refer to figure 7 (from ref. 1), which relates the compressive layer thickness to the Almen A-scale intensity. A tolerance range of  $\pm 0.001$  A should be specified.

3. For cross sections between 1.02 and 0.38 mm (0.040 and 0.015 in.) thick use the second step only (step b in item 1). See figure 8 for directions on shot peening a typical compressor blade.

4. All edges and corners to be peened shall be broken 0.127 to 0.254 mm (0.005 to 0.010 in.) prior to peening.

5. Dimensional limits apply after peening.

6. For a smoother surface finish 10 percent of the compressive layer can be polished off by using a slow polishing procedure that generates no heat.

7. A demarcation line caused by masking has no effect, but it is recommended that shot peening be blended into the untreated areas unless there is a strict surface-finish requirement on an adjacent surface.

8. If temperatures high enough to cause stress relieving will be encountered by the component, shot peening should not be used. The compressive stresses induced by shot peening will relax to low levels at high temperatures ( $\sim 480$  °C (900 °F) for Ti-6Al-4V).

Lewis Research Center  
National Aeronautics and Space Administration  
Cleveland, Ohio, February 3, 1987

## References

1. Shot Peening Applications. Sixth Edition, Metal Improvement Company, Paramus, NJ, 1980.
2. Starkey, W.L.; Marco, S.M.; and Collins, J.A.: The Effect of Fretting on Fatigue Characteristics of Titanium-Steel and Steel-Steel Joints. ASME Paper 57-A-113, 1957.
3. Campbell, J.E.: Shot Peening for Improved Fatigue Properties and Stress Corrosion Resistance. MCIC-71-02, Metals and Ceramics Information Center, Dec. 1971. (AD-735409.)
4. Thomassen, L.; Sinnott, M.J.; and Demmler, A.W.: The Influence of Surface Treatment on the Fatigue Properties of Titanium and Titanium Alloys. WADC Technical Report 53-437, Feb. 1954.
5. Brodrick, R.F.: Protective Shot Peening of Propellers. WADC Technical Report 55-56, 1955. (Part 1: PB-111802/Part 2: PB-121464.)
6. Simpson, R.S.: Development of a Mathematic Model for Predicting the Percentage Fatigue Life Increase Resulting from Shot Peened Components. AFWAL-TR-84-3116, Apr. 1985. (AD-A155774.)

1. Report No. NASA TP-2711	2. Government Accession No.	3. Recipient's Catalog No.	
4. Title and Subtitle Shot Peening for Ti-6Al-4V Alloy Compressor Blades		5. Report Date April 1987	
		6. Performing Organization Code	
7. Author(s) Gerald A. Carek		8. Performing Organization Report No. E-3430	
		10. Work Unit No.	
9. Performing Organization Name and Address National Aeronautics and Space Administration Lewis Research Center Cleveland, Ohio 44135		11. Contract or Grant No.	
		13. Type of Report and Period Covered Technical Paper	
12. Sponsoring Agency Name and Address National Aeronautics and Space Administration Washington, D.C. 20546		14. Sponsoring Agency Code	
15. Supplementary Notes			
16. Abstract  A test program was conducted to determine the effects of certain shot-peening parameters on the fatigue life of the Ti-6Al-4V alloy as well as the effect of a demarcation line on a test specimen. This demarcation line, caused by an abrupt change from untreated surface to shot-peened surface, was thought to have caused the failure of several blades in a multistage compressor at the NASA Lewis Research Center. The demarcation line had no detrimental effect on bending fatigue specimens tested at room temperature. Procedures for shot peening Ti-6Al-4V compressor blades are recommended for future applications.			
17. Key Words (Suggested by Author(s)) Shot peening; Fatigue; Compressor blades		18. Distribution Statement Unclassified—unlimited STAR Category 39	
19. Security Classif. (of this report) Unclassified	20. Security Classif. (of this page) Unclassified	21. No of pages 7	22. Price* A02

\*For sale by the National Technical Information Service, Springfield, Virginia 22161

NASA-Langley, 1987