

## Shunt Active Filter for Power Quality Improvement

João Afonso\*, Maurício Aredes<sup>+</sup>, Edson Watanabe<sup>+</sup>, Júlio Martins\*

\* University of Minho - Industrial Electronics Dept.

Campus de Azurém – 4800 Guimarães – Portugal

e-mail: lafonso@dei.uminho.pt

e-mail: jmartins@dei.uminho.pt

<sup>+</sup> Federal University of Rio de Janeiro – COPPE/UFRJ

Cx.P.2754 – CEP: 21945-970 Rio de Janeiro, RJ, Brazil

e-mail: aredes@coe.ufrj.br

e-mail: watanabe@coe.ufrj.br

### Abstract

This paper describes the development of a low cost shunt active power filter with digital control, which allows dynamic power factor correction and both harmonics and zero-sequence current compensation. The active filter controller is based on the instantaneous power theory (p-q theory) and was implemented using a standard 16 bits microcontroller. The p-q theory is introduced followed by the presentation of some active power filters topologies. Then a brief description of the implemented solution is made, including references to software tools used for simulation and system development. Experimental results are also presented, showing the good performance of the developed active filter.

### 1. Introduction

Due the intensive use of power converters and other non-linear loads in industry and by consumers in general, it can be observed an increasing deterioration of the power systems voltage and current waveforms. The explanation is simple. Accordingly to Fig. 1, which presents a single-phase system, the voltage across the load terminals is:

$$v_L = v_S - 2 \cdot \Delta v$$

where  $\Delta v$  is the voltage drop in the power lines impedances. Even if the supply voltage  $v_S$  is a pure sinusoid, the non-linear load input current is not, and as a result, the supply current

$$i_S = i_{L1} + i_{L2}$$

includes harmonics which makes both the voltage drop  $\Delta v$  and the load voltage ( $v_L$ ) non-sinusoidal.

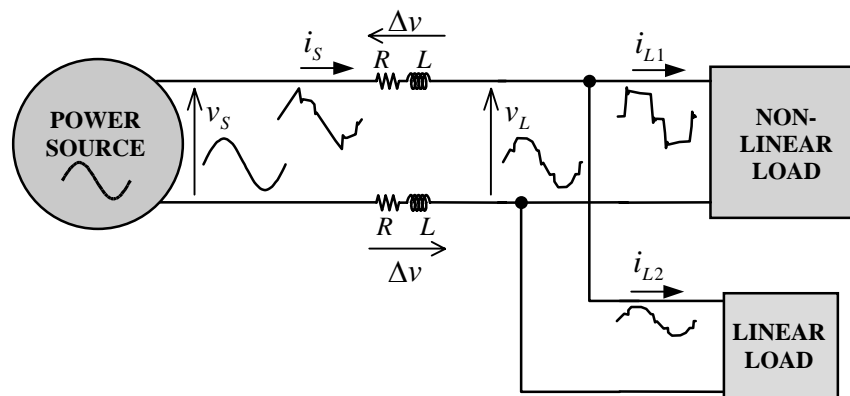

Fig. 1 – Problems caused by a non-linear load connected to the power system.

The presence of harmonics in the power lines results in greater power losses in distribution, interference problems in communication systems and, sometimes, in operation failures of electronic equipments, which are more and more sensitive since they include microelectronic control systems, which work with very low energy levels. Because of these problems, the issue of the power quality delivered to the end consumers is, more than ever, an object of great concern.

International standards concerning electrical energy consumption impose that electrical equipments should not produce harmonic contents greater than specified values. Meanwhile it is mandatory to solve the harmonic problems caused by those equipments already installed.

Passive filters have been used as a solution to solve harmonic current problems, but they present several disadvantages, namely: they only filter the frequencies they were previously tuned for; their operation cannot be limited to a certain load; resonances can occur because of the interaction between the passive filter and other loads, with unpredictable results. To cope with these disadvantages, recent efforts have been concentrated in the development of active power filters.

This paper presents a shunt active filter developed in the Industrial Electronics Department of the University of Minho, which uses a digital controller based on the p-q theory. Its main characteristics are the following:

- Dynamic power factor correction;
- Dynamic compensation of any harmonics currents with frequencies up to about 5 kHz;
- Dynamic zero-sequence current compensation;
- Flexible microcontroller-based implementation;
- Only one power converter: an inverter with just a capacitor on the DC side.
- IGBT power stage capable of compensating harmonics in three-phase systems up to 75 kVA (with the developed laboratory prototype).
- Low cost system.

## 2. The p-q theory

In 1983, Akagi *et al.* [1, 2] have proposed the "The Generalized Theory of the Instantaneous Reactive Power in Three-Phase Circuits", also known as p-q theory. It is based in instantaneous values in three-phase power systems with or without neutral wire, and is valid for steady-state or transitory operations, as well as for generic voltage and current waveforms. The p-q theory consists of an algebraic transformation (Clarke transformation) of the three-phase voltages and currents in the  $a$ - $b$ - $c$  coordinates to the  $\alpha$ - $\beta$ - $0$  coordinates, followed by the calculation of the p-q theory instantaneous power components:

$$\begin{bmatrix} v_0 \\ v_\alpha \\ v_\beta \end{bmatrix} = \sqrt{\frac{2}{3}} \cdot \begin{bmatrix} 1/\sqrt{2} & 1/\sqrt{2} & 1/\sqrt{2} \\ 1 & -1/2 & -1/2 \\ 0 & \sqrt{3}/2 & -\sqrt{3}/2 \end{bmatrix} \cdot \begin{bmatrix} v_a \\ v_b \\ v_c \end{bmatrix} \quad \begin{bmatrix} i_0 \\ i_\alpha \\ i_\beta \end{bmatrix} = \sqrt{\frac{2}{3}} \cdot \begin{bmatrix} 1/\sqrt{2} & 1/\sqrt{2} & 1/\sqrt{2} \\ 1 & -1/2 & -1/2 \\ 0 & \sqrt{3}/2 & -\sqrt{3}/2 \end{bmatrix} \cdot \begin{bmatrix} i_a \\ i_b \\ i_c \end{bmatrix} \quad (1)$$

$$p_0 = v_0 \cdot i_0 \quad - \text{instantaneous zero - sequence power} \quad (2)$$

$$p = v_\alpha \cdot i_\alpha + v_\beta \cdot i_\beta \quad - \text{instantaneous real power}$$

$$q \equiv v_\alpha \cdot i_\beta - v_\beta \cdot i_\alpha \quad - \text{instantaneous imaginary power (by definition)}$$

The power components  $p$  and  $q$  are related to the same  $\alpha$ - $\beta$  voltages and currents, and can be written together:

$$\begin{bmatrix} p \\ q \end{bmatrix} = \begin{bmatrix} v_\alpha & v_\beta \\ -v_\beta & v_\alpha \end{bmatrix} \cdot \begin{bmatrix} i_\alpha \\ i_\beta \end{bmatrix} \quad (3)$$

These quantities, illustrated in Fig. 2 for an electrical system represented in  $\alpha$ - $\beta$ - $0$  coordinates, have the following physical meaning:

$\bar{p}_0$  = mean value of the instantaneous zero-sequence power – corresponds to the energy per time unity which is transferred from the power supply to the load through the zero-sequence components of voltage and current.

$\tilde{p}_0$  = alternated value of the instantaneous zero-sequence power – it means the energy per time unity that is exchanged between the power supply and the load through the zero-sequence components. The zero-sequence power only exists in three-phase systems with neutral wire. Furthermore, the systems must have unbalanced voltages and currents, or multiple of 3 harmonics in both voltage and current of at least one phase.

$\bar{p}$  = mean value of the instantaneous real power – corresponds to the energy per time unity which is transferred from the power supply to the load.

$\tilde{p}$  = alternated value of the instantaneous real power – It is the energy per time unity that is exchanged between the power supply and the load.

$q$  = instantaneous imaginary power – corresponds to the power that is exchanged between the phases of the load. This component does not imply any transference or exchange of energy between the power supply and the load, but is responsible for the existence of undesirable currents, which circulate between the system phases. In the case of a balanced sinusoidal voltage system and a balanced load, with or without harmonics,  $\bar{q}$  (the mean value of the instantaneous imaginary power) is equal to the conventional reactive power ( $\bar{q} = 3 \cdot V \cdot I_1 \cdot \sin \phi_1$ ).

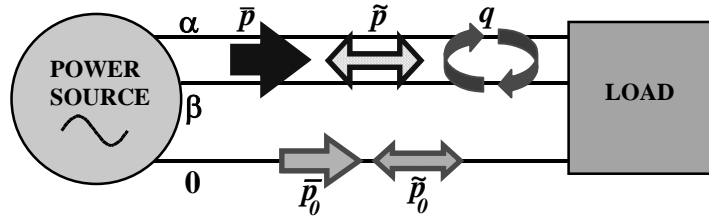

Fig. 2 – Powers components of the p-q theory in  $\alpha$ - $\beta$ -0 coordinates.

### The p-q theory applied to active filters

From all the power components obtained through the p-q theory, only  $\bar{p}$  and  $\bar{p}_0$  are desirable, as they correspond to the energy transferred from the supply to the load. The other quantities can be compensated using a shunt active power filter (Fig. 3). Even  $\bar{p}_0$ , which is related to a load unbalance (an undesirable operation condition), should be compensated whenever possible. *Watanabe et al.* [3, 4] presented a way to compensate  $\bar{p}_0$ , without the need of using any power supply in the active filter. They showed that the value of  $\bar{p}_0$  can be delivered from the power source to the active filter through the  $\alpha$ - $\beta$  coordinates, and then the active filter can supply this power to the load through the 0 coordinate (see Fig. 3). This means that the energy previously transferred from the source to the load through the zero-sequence components of voltage and current, is now delivered from the source phases through the active filter, in a balanced way.

It is also possible to see in Fig. 3 that the active filter capacitor is only necessary to compensate  $\tilde{p}$  and  $\tilde{p}_0$ , since these quantities must be stored in this component at one moment to be later delivered to the load. The instantaneous imaginary power ( $q$ ), which includes the conventional reactive power, can be compensated without any capacitor.

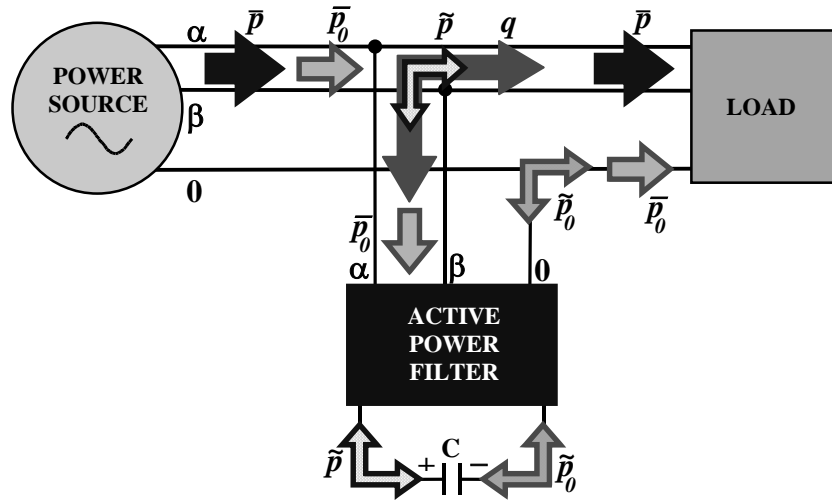

Fig. 3 - Compensation of power components  $\tilde{p}$ ,  $q$ ,  $\tilde{p}_0$  and  $\bar{p}_0$  in  $\alpha$ - $\beta$ -0 coordinates.

If the undesired power components ( $\bar{p}_0$ ,  $\tilde{p}_0$ ,  $\tilde{p}$ ,  $\bar{q}$ ,  $\tilde{q}$ ) are compensated, and for a three-phase system with balanced sinusoidal voltages, the supply currents are also sinusoidal balanced, and in phase with the voltages. In other words, the power supply “sees” the load as a purely resistive symmetrical load.

Since all the instantaneous zero-sequence power will be compensated, the reference compensation current in the 0 coordinate is  $i_0$  itself:  $i_{c0}^* = i_0$

To calculate the reference compensation currents in the  $\alpha$ - $\beta$  coordinates, the expression (3) is inverted and the powers to be compensated ( $p_x$  and  $q_x$ ) are used:

$$\begin{bmatrix} i_{c\alpha}^* \\ i_{c\beta}^* \end{bmatrix} = \frac{1}{v_\alpha^2 + v_\beta^2} \cdot \begin{bmatrix} v_\alpha & -v_\beta \\ v_\beta & v_\alpha \end{bmatrix} \cdot \begin{bmatrix} p_x \\ q_x \end{bmatrix}$$

$$p_x = \tilde{p} - \Delta\bar{p} \quad \Delta\bar{p} = \bar{p}_0 \quad (4)$$

$$q_x = q = \bar{q} + \tilde{q}$$

In order to obtain the reference compensation currents in the  $a$ - $b$ - $c$  coordinates the inverse of the transformation given in expression (1) is applied:

$$\begin{bmatrix} i_{ca}^* \\ i_{cb}^* \\ i_{cc}^* \end{bmatrix} = \frac{\sqrt{2}}{\sqrt{3}} \cdot \begin{bmatrix} 1/\sqrt{2} & 1 & 0 \\ 1/\sqrt{2} & -1/2 & \sqrt{3}/2 \\ 1/\sqrt{2} & -1/2 & -\sqrt{3}/2 \end{bmatrix} \cdot \begin{bmatrix} i_{c0}^* \\ i_{ca}^* \\ i_{c\beta}^* \end{bmatrix} \quad (5)$$

$$i_{cn}^* = -(i_{ca}^* + i_{cb}^* + i_{cc}^*)$$

### 3. Active Filters

There are basically two types of active filters: the shunt type and the series type. It is possible to find active filters combined with passive filters as well as active filters of both types acting together.

Fig. 4 presents the electrical scheme of a shunt active filter for a three-phase power system with neutral wire, which is able to compensate for both current harmonics and power factor. Furthermore, it allows load balancing, eliminating the current in the neutral wire. The power stage is, basically, a voltage-source inverter controlled in a way that it acts like a current-source. From the measured values of the phase voltages ( $v_a, v_b, v_c$ ) and load currents ( $i_a, i_b, i_c$ ), the controller calculates the reference currents ( $i_{ca}^*, i_{cb}^*, i_{cc}^*, i_{cn}^*$ ) used by the inverter to produce the compensation currents ( $i_{ca}, i_{cb}, i_{cc}, i_{cn}$ ). This solution requires 6 current sensors and 4 voltage sensors, and the inverter has 4 legs (8 power semiconductor switches).

For balanced loads (three-phase motors, three-phase adjustable speed drives, three-phase controlled or non-controlled rectifiers, etc) there is no need to compensate for the current in neutral wire. These allow the use of a simpler inverter (with only three legs) and only 4 current sensors. It also eases the controller calculations.

Fig. 5 shows the scheme of a series active filter for a three-phase power system. It is the dual of the shunt active filter, and is able to compensate for distortion in the power line voltages, making the voltages applied to the load sinusoidal (compensating for voltage harmonics). The filter consists of a voltage-source inverter (behaving as a controlled voltage source) and requires 3 single-phase transformers to interface with the power system.

The series active filter does not compensate for load current harmonics but it acts as high-impedance to the current harmonics coming from the power source side. Therefore, it guarantees that passive filters eventually placed at the load input will not drain harmonic currents from the rest of the power system. Another solution to solve the load current harmonics is to use a shunt active filter together with the series active filter (Fig. 6), so that both load voltages and the supplied currents are guaranteed to have sinusoidal waveforms.

### 4. Simulation tools

Simulation is a powerful way to reduce development time and ensure the proper fulfilment of critical steps. During the development process of the shunt active filter, simulations were performed, which allowed the study of its behaviour under different operation conditions, and permitted the tuning of some controller parameters together with the optimisation of the active filter components values. There are not many simulation tools that allow working with electrical systems, power electronics and control systems, in the same integrated environment. *Matlab/Simulink* and the *Power System Blockset* were used as simulation tools in this case and are briefly described in the following paragraphs.

#### *Matlab/Simulink*

*Matlab* is a high-level language oriented toward engineering and scientific applications. It has evolved over a ten-year history to become a popular, flexible, powerful, yet simple language. It has served as an effective platform for more than twenty toolboxes supporting specialised engineering and scientific applications, covering areas from symbolic computation to digital filter design, control theory, fuzzy logic, and neural nets. It is to be used interactively, and supports also the ability to define functions and scripts, and dynamically links with C and Fortran programs. Recent trends in the *Matlab* language have focused on an object-oriented graphics capability that permits a rich Graphical User Interface (GUI) construction [5].

*Simulink* is built on top of the *Matlab*. It is an interactive environment for modelling and simulating a wide variety of dynamic systems, including linear, non-linear, discrete-time, continuous-time, and hybrid systems. It combines the power and ease-of-use of an application package with the flexibility and extensibility of a language. The user can build block diagram models with click-and-drag operations, change model parameters on-the-fly, and display results "live" during a simulation. This tool is also a uniquely open system, allowing to choose, adapt, and create software and hardware components to suit each application [6].

Together, *Simulink* and *Matlab* provide an ideal integrated environment for developing models, performing dynamic system simulations, and designing and testing new ideas.

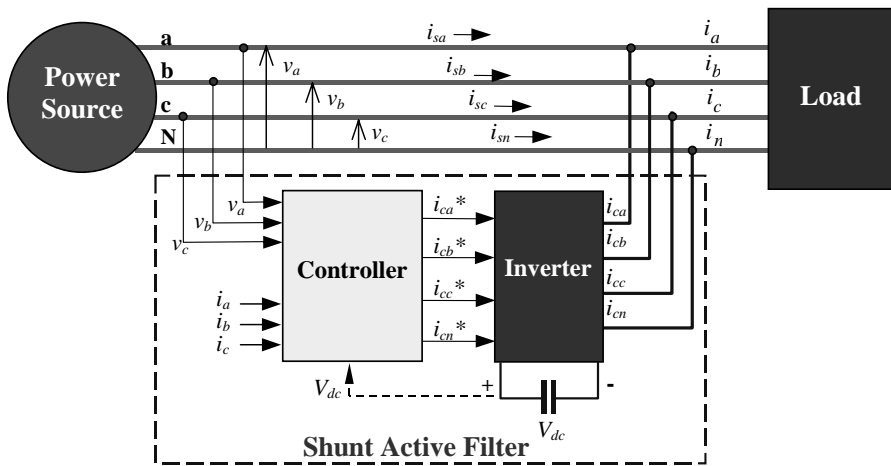

Fig. 4 - Shunt active filter in a three-phase power system with neutral wire.

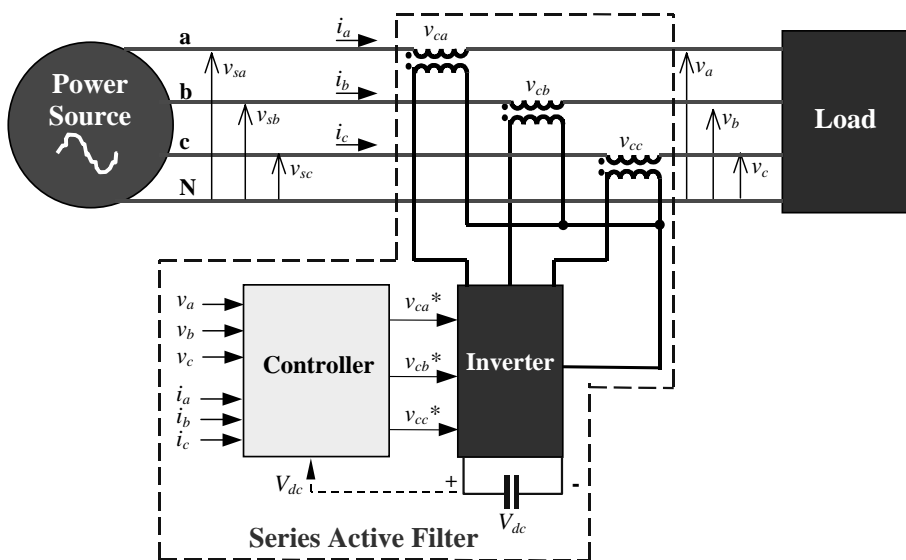

Fig. 5 - Series active filter in a three-phase power system.

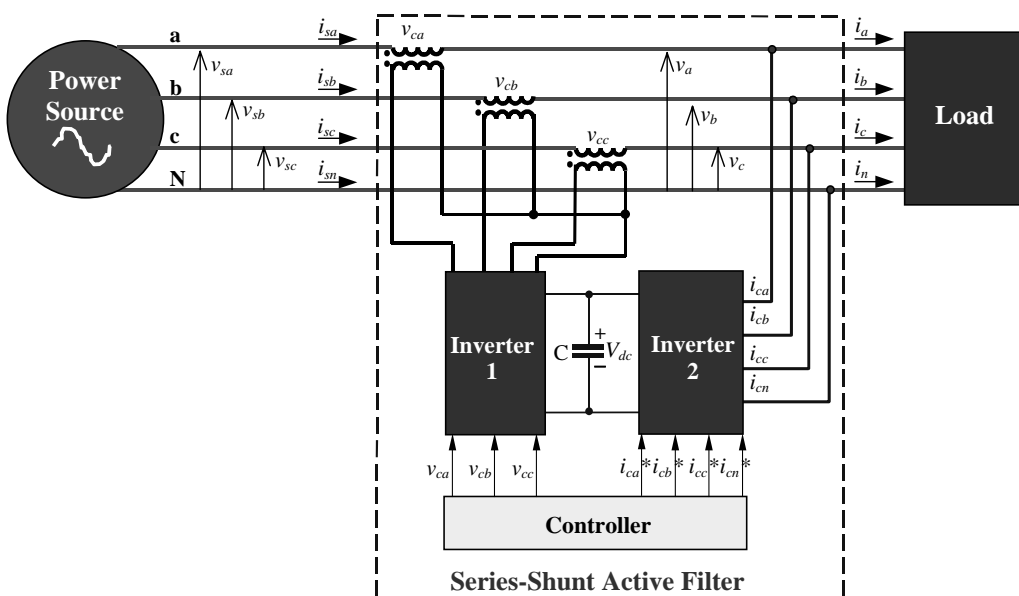

Fig. 6 – Series-shunt active filter in a three-phase power system.

**Power System Blockset**

*Power System Blockset* is a state-of-the-art design tool, developed by scientists and researchers at TEQSIM, Inc., and Hydro-Québec, for modelling and simulating electric power systems within the *Simulink* environment [7]. *Power System Blockset* block library contains *Simulink* blocks that represent common components and devices found in electrical power networks. Most of the blocks are based on well-known electro-magnetic and electro-mechanical equations. These blocks use standard electrical symbols, making it easy to create intuitive graphical models of electrical power systems. *Power System Blockset* extends *Simulink* to provide a unique environment for multi-domain modelling and controller design. By connecting the electrical parts of the simulation to blocks from *Simulink's* extensive modelling library, it is possible to rapidly draw the circuit topology and simultaneously analyse the circuit's interactions with mechanical, thermal, and control systems.

**5. The implemented shunt active filter**

The implemented shunt active filter consists, basically, of a digital controller and a current-controlled voltage source inverter (Fig. 4).

The controller implementation is based in a standard 16-bit microcontroller (*Intel* 80296SA) with minimum additional hardware to interface with the sensors and the inverter. Using the p-q theory, the controller calculates the reference compensation currents to be synthesized by the inverter. These calculations were optimised (namely using integer programming) to save CPU time and memory and improve the active filter dynamic and steady-state response. The microcontroller software was developed using the *Tasking EDE* (Embedded Development Environment) for 196/296. This compiler, specific for the *Intel* MCS96 family of microcontrollers, allows the development of programs in C or Assembler language.

The inverter, detailed in Fig. 7, uses a single capacitor in the DC side (the active filter does not need any power supply). Current-control is implemented, basically, comparing the reference currents calculated by the controller with the measured values of compensation currents, in order to produce command signals for the inverter semiconductor switches. An inductive filter is placed at the inverter output to limit the ripple of the compensation currents. An RC high-pass filter is set in the active filter output to filter the inverter commutation frequencies.

The capacitor voltage,  $V_{dc}$ , must be regulated, which is guaranteed by the same microcontroller that generates the current references.

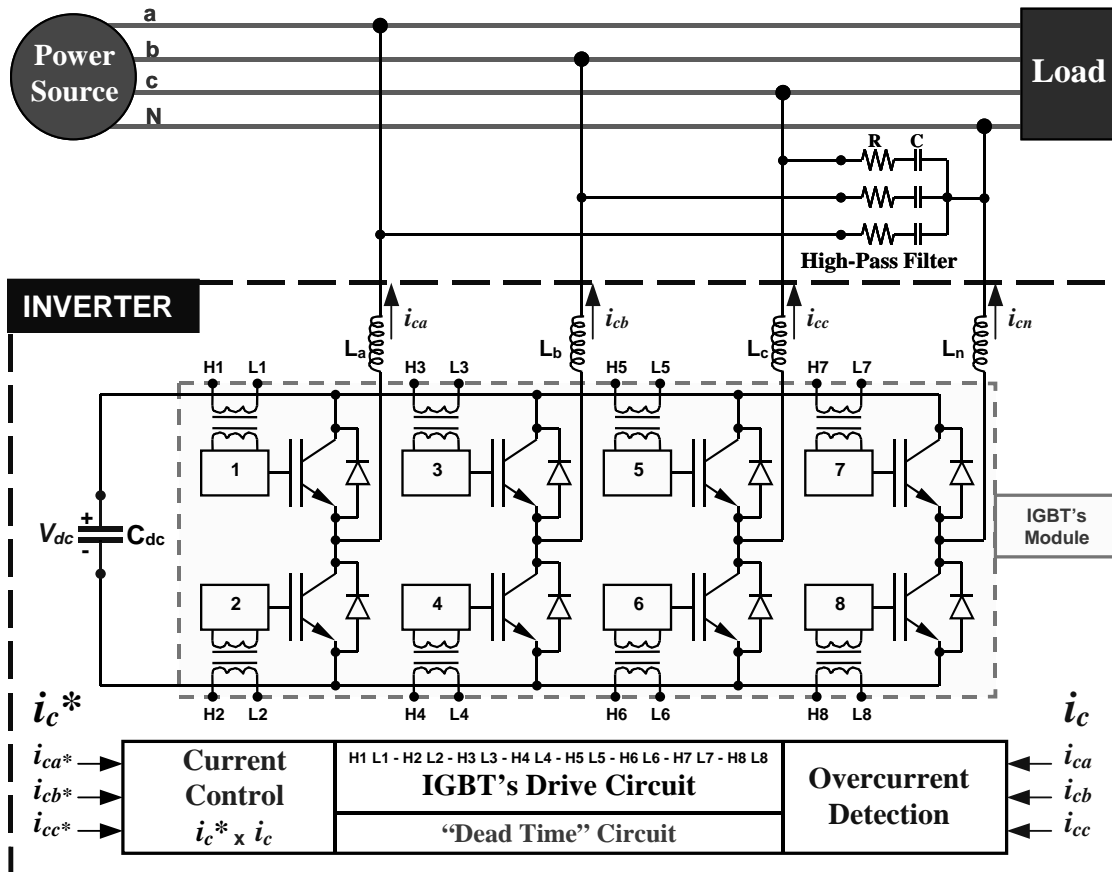

Fig. 7 – Details of the shunt active filter inverter.

## 6. Experimental results

The following figures illustrate the performance of the developed shunt active filter for different operation conditions. Although the power system and the active filter are three-phase, for the sake of better understanding, the figures only show waveforms for one phase. The reference and the compensation currents of the shunt active filter are also displayed (for the same phase).

In the first case (Fig. 8), the power system operates with a linear and almost “pure”  $L$  load, which can be confirmed noting that the supply current ( $i_{sa}$ ) is almost  $90^\circ$  delayed regarding to the phase voltage ( $v_a$ ). The active filter controller calculates the reference compensation current ( $i_{ca}^*$ ), and as soon as it is turned-on, the compensation current ( $i_{ca}$ ) produced by the inverter makes  $i_{sa}$  in phase with  $v_a$ . In other words, the shunt active filter compensates the load power factor and it does so almost instantaneously (Fig. 9).

Fig. 10 shows what happen when the power system is operating with a non-linear load. The source current is distorted (and delayed in relation to the voltage). After the active filter is turned-on,  $i_{sa}$  becomes sinusoidal and in phase with  $v_a$ . Fig. 11 presents the transitory that occurs when the active filter inverter is turned-on. Once again, the current distortion and the delay are immediately corrected.

Fig. 12 illustrates the response of the system to a load change. At the beginning it operates with a linear  $RL$  load and then a non-linear load (non-controlled three-phase rectifier) is connected. When the filter is on, the load changing is fully compensated in a half cycle. The current increases in amplitude because the demanded energy becomes larger with the new load, but the source current remains sinusoidal and in phase with the voltage. The compensation current when the active filter is on, is also showed.

The ripple observed in the supply current waveform when the shunt active filter in operating occurs due to the inverter commutation. However, it only seems to be relevant because the loads used to obtain the experimental results were relatively small. Operating with larger loads the current ripple would be negligible. Besides, this is a high-frequency ripple, which is easily filtered by the power system.

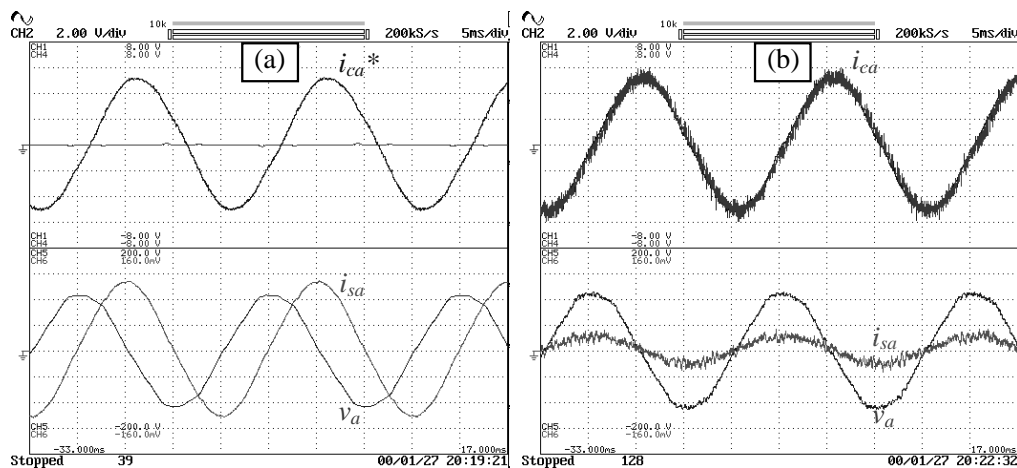

Fig. 8 - Power system with  $RL$  load before (a) and after (b) the active filter inverter is turned on.

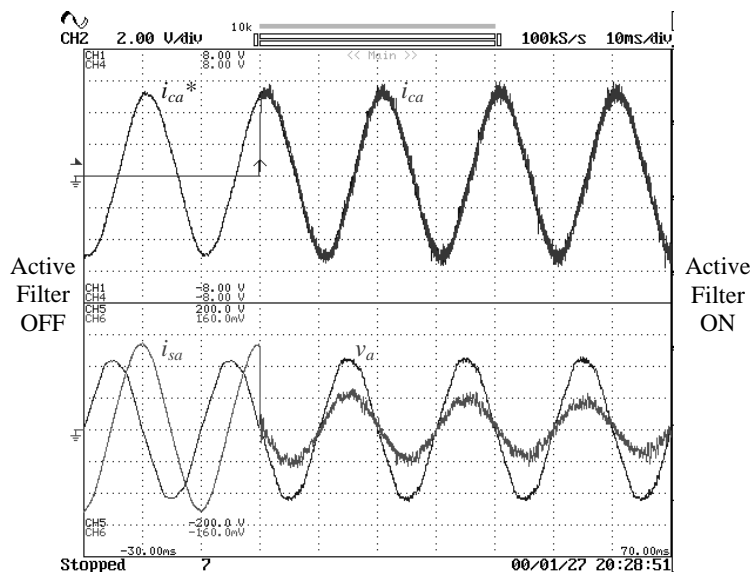

Fig. 9 - Power system with  $RL$  load: transitory when the active filter inverter is turned-on.

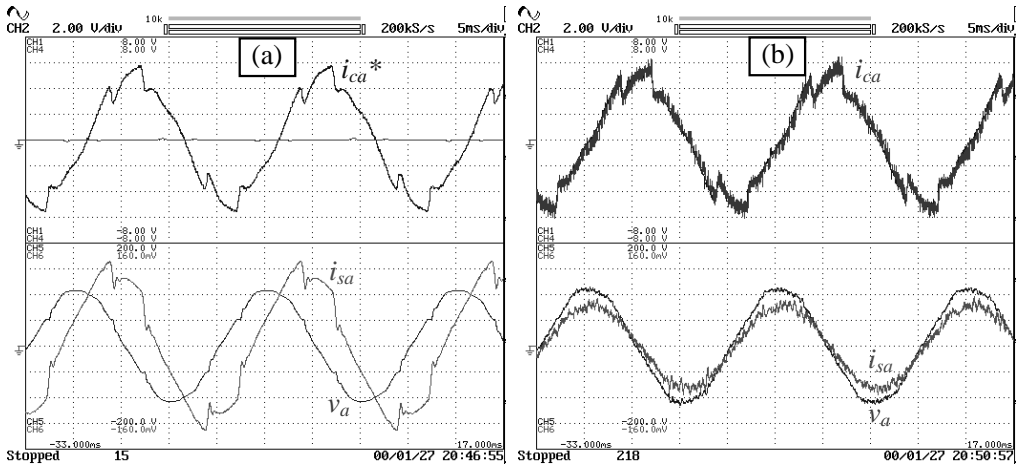

Fig. 10 - Power system with non-linear load: (a) Active filter inverter off; (b) Active filter inverter on.

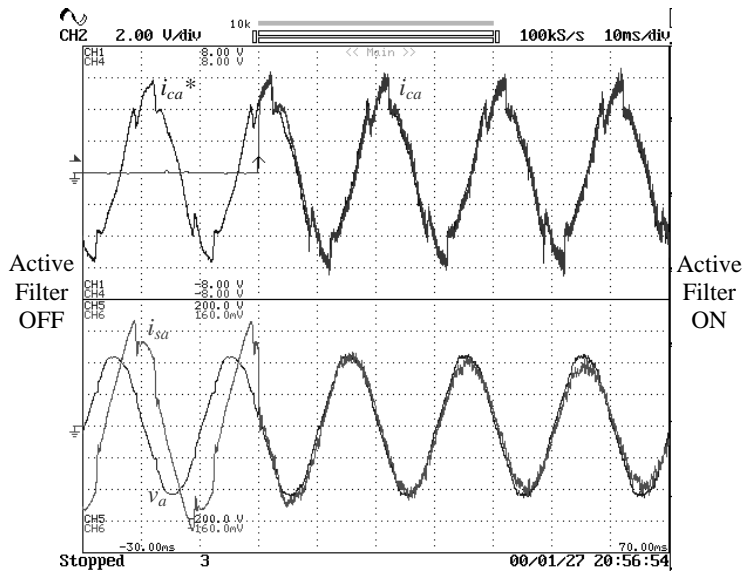

Fig. 11 - Power system with non-linear load: transitory when the active filter inverter is turned-on.

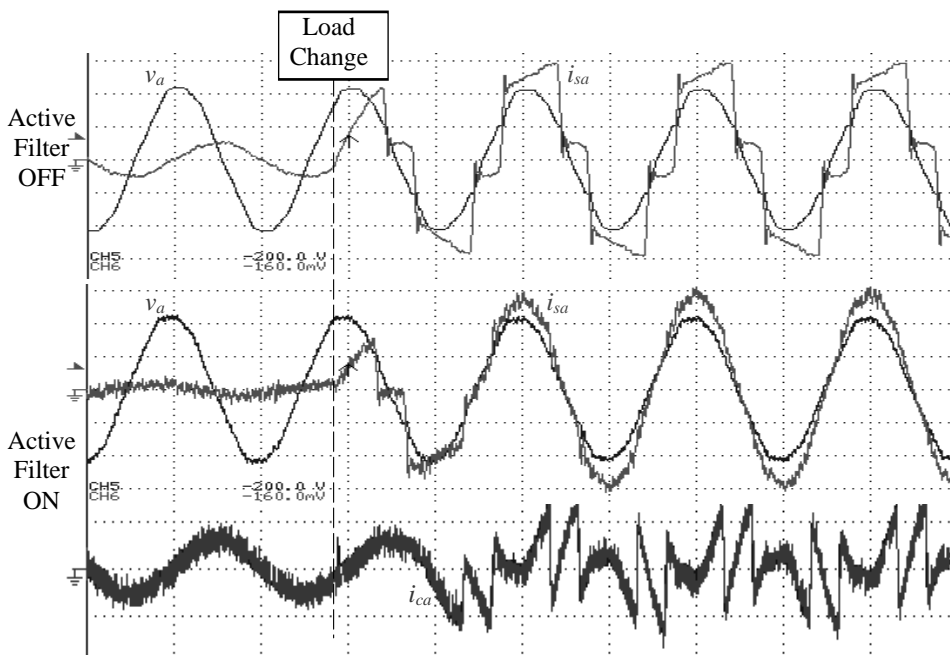

Fig. 12 - Response to a load change, with the shunt active filter off and on.



## 7. Conclusions

This paper presents a shunt active power filter as a reliable and cost-effective solution to power quality problems.

The active filter controller is based on the p-q theory, which proved to be a powerful tool, but simple enough to allow the digital implementation of the controller using a standard and inexpensive microcontroller with minimum additional hardware.

The filter presents good dynamic and steady-state response and it can be a much better solution for power factor and current harmonics compensation than the conventional approach (capacitors to correct the power factor and passive filters to compensate for current harmonics). Besides, the shunt active filter can also compensate for load current unbalances, eliminating the neutral wire current in the power lines. Therefore, this active filter allows the power source to see an unbalanced reactive non-linear load, as a symmetrical resistive load.

The proposed low-cost solution allows the use of a large number low-power active filters in the same facility, close to each problematic load (or group of loads), avoiding the circulation of current harmonics, reactive currents and neutral currents through the facility power lines. This solution reduces the power lines losses and voltage drops, and avoids voltage distortions at the loads terminals.

## 8. References

- [1] H. Akagi, Y. Kanazawa, A. Nabae, Generalized Theory of the Instantaneous Reactive Power in Three-Phase Circuits, *IPEC'83 - Int. Power Electronics Conf.*, Tokyo, Japan, 1983, pp. 1375-1386.
- [2] H. Akagi, Y. Kanazawa, A. Nabae, Instantaneous Reactive Power Compensator Comprising Switching Devices without Energy Storage Components", *IEEE Trans. Industry Applic.*, vol. 20, May/June 1984.
- [3] E. H. Watanabe, R. M. Stephan, M. Aredes, New Concepts of Instantaneous Active and Reactive Powers in Electrical Systems with Generic Loads, *IEEE Trans. Power Delivery*, vol. 8, no. 2, April 1993, pp. 697, 703.
- [4] M. Aredes, E. H. Watanabe, New Control Algorithms for Series and Shunt Three-Phase Four-Wire Active Power Filters, *IEEE Trans. Power Delivery*, vol 10, no. 3, July 1995, pp. 1649-1656.
- [5] MATLAB: High-Performance Numeric Computation and Visualization Software – Reference Guide, The MathWorks Inc., April 1993.
- [6] SIMULINK: The Dynamic System Simulation Software-User's Guide, MathWorks Inc., April 1993.
- [7] Power System Blockset User's Guide, TEQSIM International Inc. and Mathworks Inc., 1998.