

D. S. Kochhar and B. L. Wills

Dept. of Systems Design
University of Waterloo
Waterloo, Ontario, Canada

Summary

This paper describes a GPSS/360 simulation of a two-man machine model where the performance of both operators as they together perform a task comprising of a series of individual and/or interacting subtasks is simulated. The program considers inter and intra operator variance, and such factors as operator proficiency, stress tolerance and partner confidence. Output for various systems consists of areas of operator overload and underload, subtask and task failure or success and a comparison of the standard and actual execution times.

Introduction

Engineering design is the process of organizing and analysing various systems or devices in order to choose from among them the ones which acceptably perform the task at hand. When needs are slow to appear and demands for change modest, designs usually exhibit a slow steady evolutionary improvement. With more urgent needs, development of designs is along a number of channels and tends to be more innovative. At the very base of engineering design are two processes:

1. the process of creating a set of design proposals
2. a decision process for evaluating these design proposals

One can distinguish between two main approaches to engineering design which Gagné defines⁹ as the inventor approach and the systems approach. The former deals directly in terms of the physical hardware of the final design and evaluations of adequacy are achieved by experiments with this hardware. The systems approach, while ultimately concerned with hardware, initially leads the designer to work with suitable descriptions of the hardware components. The systems designer translates his ideas as to how the task can be accomplished into the language of mathematics, and the evaluations of the adequacy of the design are based on experiments with his mathematical model. The mathematical experimentation is called simulation.

In the design of systems involving both man and hardware the emphasis heretofore has invariably been on the selection of optimum hardware with the assumption (hope?) that suitable personnel could readily be found and integrated with the system. On many occasions this restricted design viewpoint has had unfavourable repercussions. It is therefore imperative that techniques for including the human elements be developed, especially from the systems approach.

Man-machine systems are those in which personnel performance and interpersonal relationships are conceded to be of major importance to total system effectiveness. In the design of such systems an attempt must be made to build models which take into account such factors as human stress, stress tolerance, learning, proficiency, and co-worker confidence. These models must be amenable to simulation using computers. Psychologists are often able to pursue such problems as the measurement of individual aptitudes, capacities, skills, motivation, etc., quite independently of the question of operational system performance.

Effective man-machine system models must draw on the knowledge available from this source at present and systems designers must indicate directions for further experimentation and research.

This paper looks at a technique, after Siegel and Wolf⁵, for modelling a class of multi-task man-machine systems. The model includes several important human factors and is simulated for design and analysis purposes using a next-event simulation language such as GPSS (General Purpose Systems Simulator). The results of the simulation can aid in answering such questions as:

1. For a particular equipment design and fixed operator procedure, can an average operator be expected to complete successfully all actions required in the performance of the task within a given time limit?
2. How would the probability of task success and the load on an operator change for slower or faster operators and longer or shorter periods of allotted time?
3. How do individual learning rates affect overall task success and the ability to sustain greater stress.
4. How great is the stress on each operator in the system during his performance and in which sections of the task is he over or under stressed? Conversely, what time limits should be set or what system changes should be implemented so as to have operator loading within permissible limits?
5. How does the probability of task success vary with changes in operator stress tolerance limits and operator skill?

Two Operator Man-Machine System Model

For illustrative purposes we will consider a particular two operator system composed of a sequence of subtasks as shown in Fig. 1. In the given system there are four types of subtasks:

1. Subtasks (ST) performed by operator 1
ST1,1 ; ST2,1 ; ST3,1 ; etc.
2. Subtasks performed by operator 2
ST1,2 ; ST2,2 ; ST3,2 ; etc.
3. Subtasks performed by both operators
ST8,1,2
4. Non-essential subtasks. These subtasks are not required for the successful completion of the overall operation but should be performed if there is sufficient time.

ST 6NE,1 ; ST 1ONE,2

An assumption of major importance in the construction of a model for the given system is that operator loading or stress must be accounted for⁵. Operator stress may be caused by a number of factors. For example:

- a) falling behind in time on the assigned task sequence
- b) a realisation that one's co-worker(s) are not performing adequately
- c) an inability to complete successfully any subtask on the first attempt with the possible need to then repeat the subtask
- d) the need to wait for hardware responses or to wait

for equipment repair.

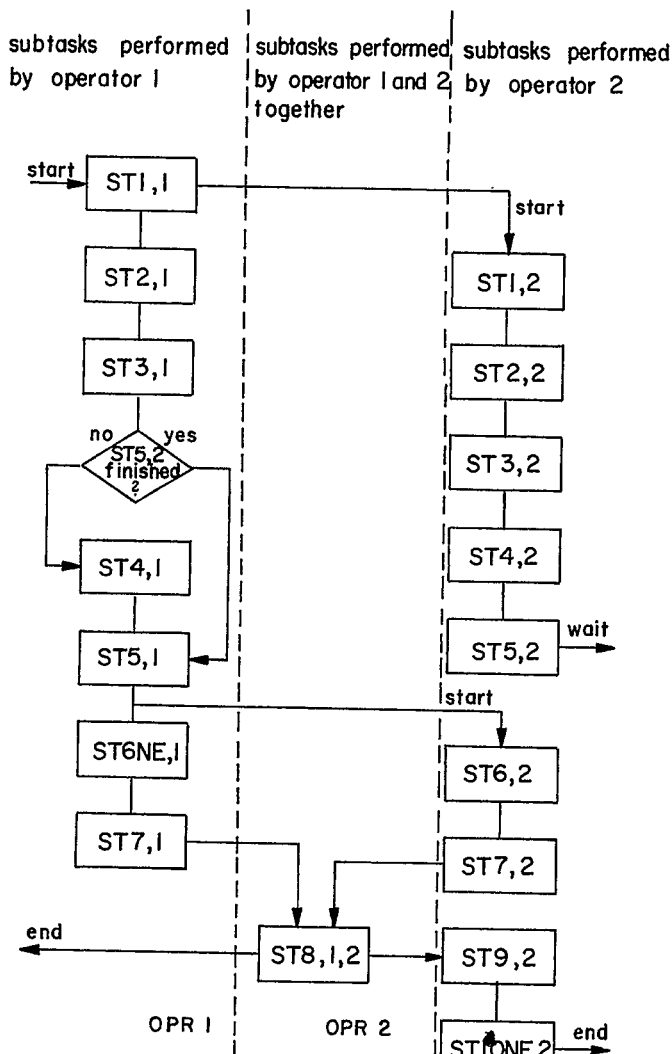

FIG. 1: The Subtask Sequence

Since stress is based on time pressure, the model is time oriented. Simulation begins at $t = 0$ and the performance of each subtask by each operator is simulated. Statistics are maintained for the execution time of each subtask, subtask failures or successes, operator stresses and waiting times. The total task execution times for each operator are also tabulated. Subtask success or failure is stochastically determined on the basis of operator stress together with an input probability model. The execution time for each subtask is determined on the basis of operator stress and operator skill. By observing the results of a suitably large number of runs through the entire task sequence, the total system performance can be estimated.

Model Details

Initial Parameters

Siegel and Wolf describe four such parameters. The task sequence here obviates the necessity of using the

time period for cyclic tasks as there are no cyclic subtasks in the system. The other three are described below along with two additional parameters.

1. Total Allotted Task Time (T_1 and T_2 for operators 1 and 2 respectively). This parameter is the total time allocated to each operator to perform the series of subtasks. It may or may not be equal for both operators.

2. Operator Skill Factor (OSF_1 and OSF_2 for operators 1 and 2 respectively). This factor is used to account for individual variance in work skill and is similar to performance rating in work measurement studies. An average operator has an OSF equal to 1.0. An operator with an $OSF = 0.8$ would require only 80% of the time taken by an average operator when both perform the same task under similar conditions.

In order to include the effects of learning on subtask execution time, an appropriate learning factor may be incorporated into the operator skill factor.

3. Operator Stress Threshold Parameters (M_1 and M_2 for operators 1 and 2 respectively). Some digression is required in order that this parameter can be fully defined. Current psychological theory suggests⁵ that the effect of stress on an individual (to a certain point) is to act as an organizing agent which results in a faster and more coherent operator response. In the simulation model, therefore, the effect of stress below a specified value, called the operator stress threshold, is to organize operator faculties. This results in a faster subtask execution time and a higher probability of subtask success. Above the threshold for each operator, execution time increases and subtask failure becomes more likely. On the basis of current research⁵, $M = 2.3$, has been found to be appropriate for average operators. This indicates that an average operator begins to become slower and less accurate at the point at which he has 2.3 times as much work to do as he has time remaining to do it.

4. Standard Execution Times--Each of the subtasks has a standard execution time defined as the time taken by an operator of average skill while not under stress. Since no operator is likely to perform the same task in precisely the same time on two different occasions, a suitable probability distribution is incorporated to account for this inherent variability. For the illustrative two-operator system described in this paper, a normal distribution has been chosen. Figure 2 lists mean (average) and standard deviations for the standard execution times for each of the eighteen subtasks in the system.

5. Subtask Success Parameters (X , Y and Z) These parameters specify the function to be used for determining the probability of success for each subtask. This function will be described in more detail later in the paper.

Simulation Parameters

The following describes the parameters which are computed for each operator immediately prior to the start of each subtask.

I Urgency of the Situation

One of three states of urgency is determined prior to the execution of each subtask for each operator. The situation is:

- Non-urgent: when enough time remains to complete both the essential and non-essential subtasks. In this case the operator stress remains constant.
- Urgent: when enough time remains to complete all essential subtasks, but this time is insufficient to complete all essential and non-essential subtasks.
- Highly urgent: when insufficient time remains to complete even the essential subtasks. In this case the stress for operator k is computed as

$$s_k = \frac{\sum_{i=j}^n \bar{t}_{i,k}}{T_k - TE_k}$$

where n = total number of subtasks for operator k
j = number of next subtask to be performed
T_k = total time allotted to operator k
TE_k = elapsed time so far for operator k
t_{i,k} = Average Standard Subtask Execution Time for subtask i

FIG 2: ST Execution times for an average operator while not under stress

SUBTASK	AVERAGE EXECUTION TIME (t, in sec.)	STANDARD DEVIATION (σ, in sec.)
ST1,1	7.5	1.0
ST2,1	22.0	2.0
ST3,1	45.5	5.5
ST4,1	16.0	2.5
ST5,1	10.0	1.5
ST6NE,1	8.5	0.5
ST7,1	14.5	1.2
ST8,1,2	6.5	0.8
ST1,2	22.5	3.5
ST2,2	8.5	1.8
ST3,2	16.0	2.0
ST4,2	17.5	2.8
ST5,2	24.5	4.0
ST6,2	10.0	1.8
ST7,2	13.5	2.0
ST9,2	5.0	0.8
ST10NE,2	11.0	1.8

II Partner Stress

Should the stress of an operator rise beyond the normal value of 1.0 and his co-workers sense the change in their partner's actions they will probably modify their own actions as well. This effect is accounted for in the model by using a co-worker stress additive A_{k,l} which is the stress added to that of operator k due to the increase sensed in operator l. Thus the total stress for operator k is given by the expression

$$S_k = s_k + \sum_{l=1}^n A_{k,l} \quad l \neq k$$

where n = the number of operators

The stress additive may be computed in a number of different ways depending on the system under study. The following illustrates one method of computing this factor for a two-operator system⁵.

Stress on op. 1	Stress on op. 2	Additive stress A _{2,1}	Total stress op. 2
s ₁ = 1.0	s ₂	A _{2,1} = 0	S ₂ = s ₂ + A _{2,1} = s ₂
1 < s ₁ < M ₁	s ₂	A _{2,1} = $\frac{s_1 - 1}{M_1 - 1}$	S ₂ = s ₂ + $\frac{s_1 - 1}{M_1 - 1}$
s ₁ > M ₁	s ₂	A _{2,1} = 1	S ₂ = s ₂ + 1

III Subtask Execution Time (SET)

This is the main simulation variable in the model. The effect of situation urgency and co-worker additive stress is to change the operator stress S, which, together with the standard average execution times and standard deviation for each subtask and the operator skill factor is used to determine the subtask execution time (SET). Figure 3 shows a model for determining the SET given the total operator stress. Using this figure SET is determined by the following procedure:

Generate a random number (V_{i,k}) with mean t_{i,k} and variance σ_{i,k} (where i,k refers to subtask i for operator k)

For S_k < M_k part AB of curve in Fig. 3 is used
M_k < S_k < M_k + 1 part B'C of curve is used
S_k > M_k + 1 part CD of curve is used

As may be noted from Fig. 3 the standard deviation of the subtask execution times decreases uniformly from a value of σ at point A, to a value of zero at point B, and increases uniformly from a value of zero at B' to a value of 3σ at C to simulate rapid disorganisation above the stress threshold. Beyond point C, the average execution time and standard deviation remain constant⁵. The final expressions for subtask execution times, including the individual operator skill factor, are as follows:

Region AB

$$SET_{i,k} = \left[\frac{M_k - S_k}{M_k - 1} \right] \left[V_{i,k} - \frac{\bar{t}_{i,k}}{M_k} \right] + \frac{\bar{t}_{i,k}}{M_k} \text{ OSF}_k$$

Region B'C

$$SET_{i,k} = \left[(S_k - M_k) (3 V_{i,k} - \bar{t}_{i,k}) + \bar{t}_{i,k} \right] \text{ OSF}_k$$

Region CD

$$SET_{i,k} = \left[3 V_{i,k} - \bar{t}_{i,k} \right] \text{ OSF}_k$$

where i = subtask number
k = operator number

IV Probability of Subtask Success

Figure 4 shows the assumed variation in subtask success with operator stress. At a stress level of 1.0 the probability of success is X%. As stress increases below the threshold value M the probability of success increases linearly to a value Y%. Above the threshold this percentage decreases from a value of X% to Z%.

Results of Two-Operator System Simulation

The following is a partial description of the output obtained for several runs of the system outlined in Fig. 1. These systems were simulated using the GPSS/360 language and results were obtained using the IBM 360/75 at the University of Waterloo.

One hundred runs were made since the results did not vary appreciably with any further increase in the number of runs. The average execution time was 28.2 seconds.

Time allotted to operators 1 and 2 for their subtasks is 132 secs. and 145 secs. respectively.

Standard subtask execution times as in Fig. 2.

System A1, A2

Initial Parameters		A ₁	A ₂
OSF ₁ = 1.0	OSF ₂ = 1.0	X = 98 , 70%	
M ₁ = 2.3	M ₂ = 2.3	Y = 100, 95%	
T ₁ = 200 sec.	T ₂ = 200	Z = 96 , 55%	

SUBTASK	Operator 1					
	A1			A2		
	success	failure	omitted	success	failure	omitted
ST1,1	100	1	0	100	45	0
ST2,1	99	1	0	68	32	0
ST3,1	98	2	0	70	30	0
ST4,1	30	0	70	25	4	71
ST5,1	99	1	0	67	33	0
ST6NE,1	97	3	0	73	27	0
ST7,1	99	1	0	74	26	0
ST8,1,2	97	3	0	67	33	0

Mean and Standard Deviations of execution time.

A ₁	A ₂
μ ₁ = 120.28 sec.	μ ₁ = 123.05 sec.
σ ₁ = 6.72 sec.	σ ₁ = 9.18 sec.

SUBTASK	Operator 2					
	A1			A2		
	success	failure	omitted	success	failure	omitted
ST1,2	99	1	0	75	25	0
ST2,2	97	3	0	79	21	0
ST3,2	99	1	0	72	28	0
ST4,2	100	0	0	71	29	0
ST5,2	98	2	0	69	31	0
ST6,2	100	0	0	68	32	0
ST7,2	99	1	0	70	30	0
ST8,1,2	97	3	0	67	33	0
ST9,2	99	1	0	74	26	0
ST10NE,2	99	1	0	67	33	0

Mean and Standard Deviation of Execution Time

A ₁	A ₂
μ ₂ = 143.28 sec.	μ ₂ = 146.61 sec.
σ ₂ = 6.71 sec.	σ ₂ = 10.57 sec.

Average waiting periods after ST5,2 = 3.2 and 3.7 sec.

Percentage times operator 2 had to wait = 13% and 21%

System B1, B2

Initial Parameters		B ₁	B ₂
OSF ₁ = 0.7	OSF ₂ = 1.3	X = 98 , 70%	
M ₁ = 2.3	M ₂ = 2.3	Y = 100, 95%	
T ₁ = 132 sec.	T ₂ = 145 sec.	Z = 96 , 55%	

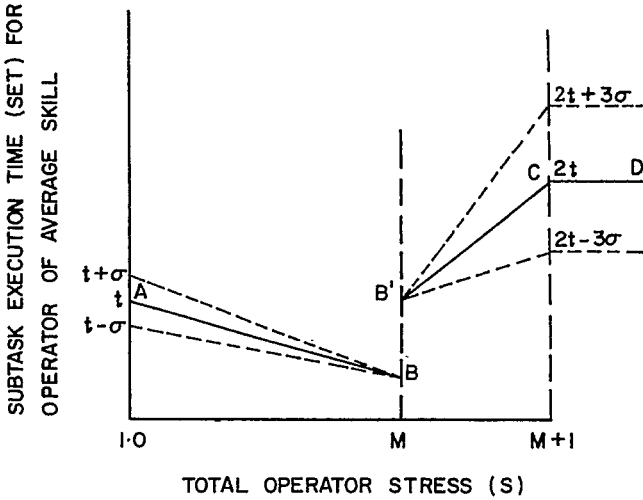

t - Average Standard Subtask Execution Time
 σ - Standard Deviation of Standard Subtask Execution Time (values of t and σ for each subtask are obtained from Fig.2)
 M - Operator Stress Threshold

FIG. 3: Model for determining Subtask Execution Times given the total operator stress⁵

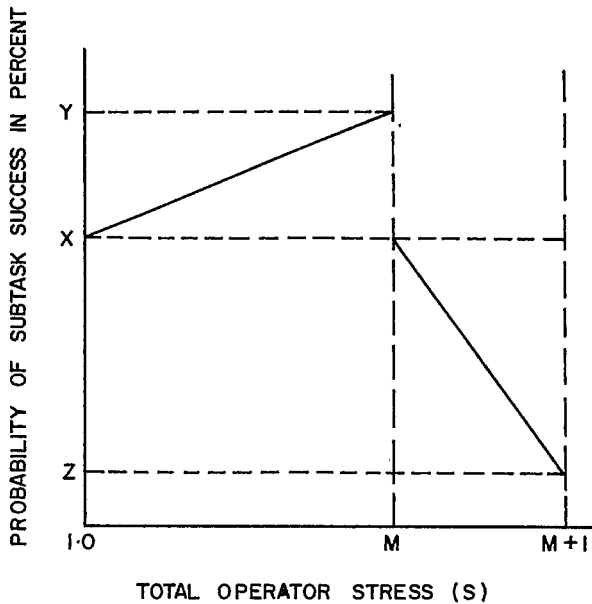

FIG. 4: Subtask Success vs Operator Stress

Operator 1						
SUBTASK	B1			B2		
	success	failure	omitted	success	failure	omitted
ST1,1	100	1	0	100	36	0
ST2,1	98	2	0	69	31	0
ST3,1	97	3	0	69	31	0
ST4,1	99	1	0	70	30	0
ST5,1	99	1	0	70	30	0
ST6NE,1	100	0	0	76	24	0
ST7,1	97	3	0	67	33	0
ST8,1,2	38	0	62	18	10	72

Mean and Standard Deviation of Execution Time

$\mu_1 = 88.77$ sec. $\mu_2 = 91.50$ sec.
 $\sigma_1 = 6.09$ sec. $\sigma_2 = 8.05$ sec.

Operator 2						
SUBTASK	B1			B2		
	success	failure	omitted	success	failure	omitted
ST1,2	100	0	0	79	21	0
ST2,2	99	1	0	71	29	0
ST3,2	98	2	0	74	26	0
ST4,2	99	1	0	75	25	0
ST5,2	99	1	0	69	31	0
ST6,2	99	1	0	77	21	2
ST7,2	96	1	3	67	24	9
ST8,1,2	38	0	62	18	10	72
ST9,2	17	0	83	10	5	85
ST10NE,2	0	0	100	0	0	100

$\mu_2 = 150.40$ sec. $\mu_2 = 150.42$ sec.
 $\sigma_2 = 5.54$ sec. $\sigma_2 = 6.14$ sec.

No waiting involved after ST5,2

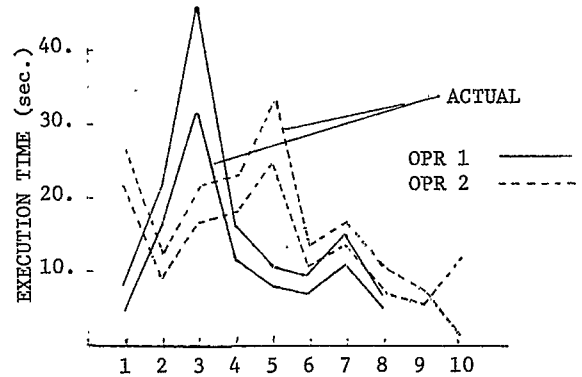
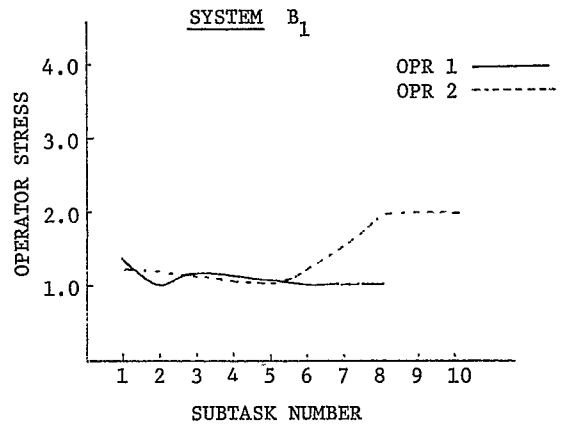
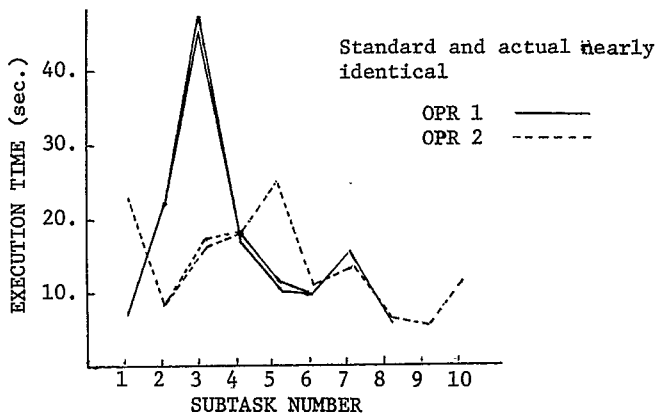
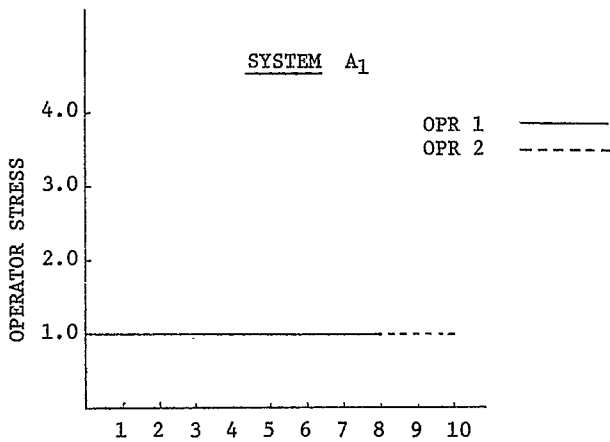

System C1, C2

Initial Parameters

$OSF_1 = 1.2$ $OSF_2 = 0.8$ $X = 98, 70\%$
 $M_1^1 = 2.7$ $M_2^2 = 1.9$ $Y = 100, 95\%$
 $T_1^1 = 132$ $T_2^2 = 145$ $Z = 96, 55\%$

Operator 1						
SUBTASKS	C1			C2		
	success	failure	omitted	success	failure	omitted
ST1,1	100	0	0	100	28	0
ST2,1	99	1	0	72	28	0
ST3,1	100	0	0	72	28	0
ST4,1	0	0	100	0	0	100
ST5,1	100	0	0	72	28	0
ST6NE,1	46	0	54	29	14	57
ST7,1	97	3	0	72	28	0
ST8,1,2	95	2	3	70	30	0

$\mu_1 = 131.93$ sec. $\mu_2 = 133.52$ sec.
 $\sigma_1 = 5.26$ sec. $\sigma_2 = 6.58$ sec.

Operator 2						
SUBTASKS	C1			C2		
	success	failure	omitted	success	failure	omitted
ST1,2	100	0	0	72	28	0
ST2,2	99	1	0	75	25	0
ST3,2	99	1	0	70	30	0
ST4,2	100	0	0	66	36	0
ST5,2	95	5	0	65	35	0
ST6,2	89	2	9	65	35	0
ST7,2	61	1	32	81	19	0
ST8,1,2	95	2	3	70	30	0
ST9,2	99	1	0	74	26	0
ST10NE,2	98	2	0	70	30	0

System D1, D2

Initial Parameters

OSF₁ = 0.7 OSF₂ = 1.3 X = 98 , 70 %
 M₁ = 1.9 M₂ = 2.7 Y = 100 , 95 %
 T₁ = 132 T₂ = 145 Z = 96 , 55 %

Operator 1						
SUBTASKS	D1			D2		
	success	failure	omitted	success	failure	omitted
ST1,1	100	2	0	100	34	0
ST2,1	97	3	0	71	29	0
ST3,1	100	0	0	73	27	0
ST4,1	99	1	0	74	26	0
ST5,1	99	1	0	75	25	0
ST6NE,1	100	0	0	75	25	0
ST7,1	99	1	0	65	35	0
ST2,1,2	5	0	95	2	1	97

D1 D2
 $\mu_1 = 86.63$ sec. $\mu_1 = 87.36$ sec.
 $\sigma_1 = 6.93$ sec. $\sigma_1 = 8.22$ sec.

Operator 2						
SUBTASKS	D1			D2		
	success	failure	omitted	success	failure	omitted
ST1,2	100	0	0	79	21	0
ST2,2	99	1	0	78	22	0
ST3,2	99	1	0	74	26	0
ST4,2	100	0	0	73	27	0
ST5,2	95	5	0	78	22	0
ST6,2	89	2	9	66	17	17
ST7,2	67	1	32	50	17	33
ST8,1,2	5	0	95	2	1	97
ST9,2	1	0	99	0	0	100
ST10NE,2	0	0	100	0	0	100

D1 D2
 $\mu_2 = 158.39$ sec. $\mu_2 = 159.49$ sec.
 $\sigma_2 = 11.46$ sec. $\sigma_2 = 11.28$ sec.

No waiting involved after ST5,2.

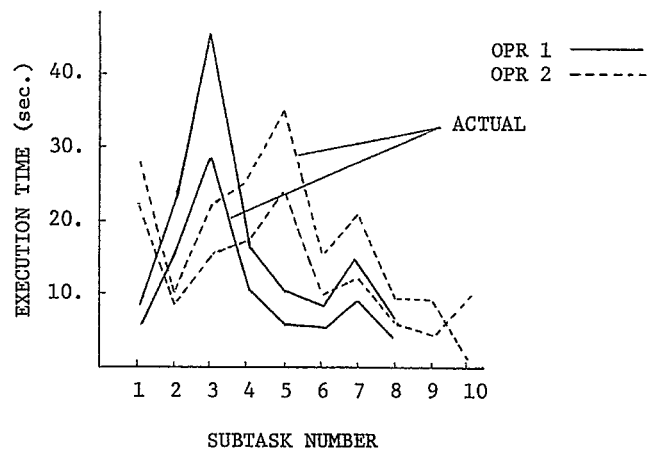
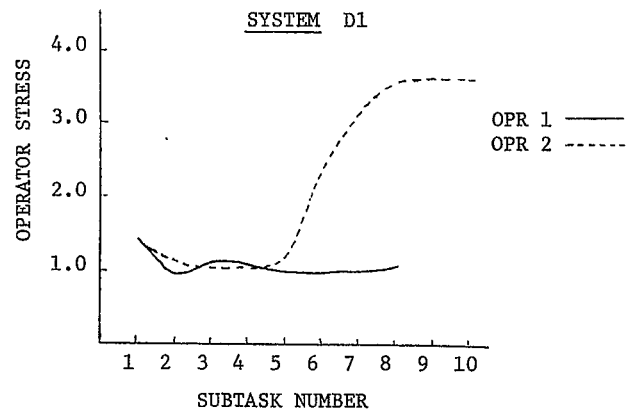
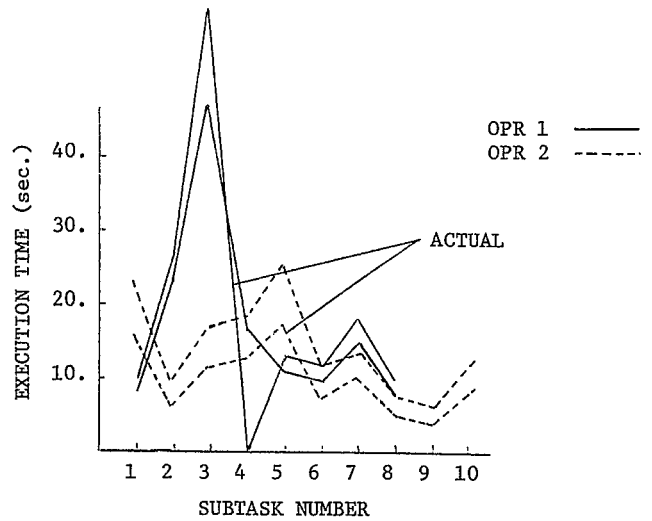
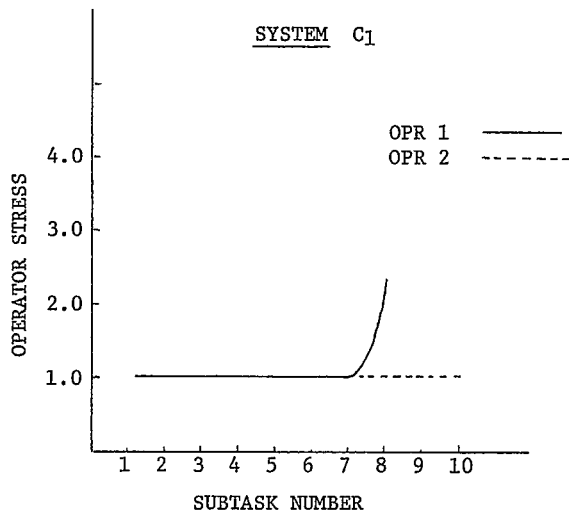

CONCLUSIONS

This system modelling technique represents a conceptual first step towards the comprehensive simulation of certain types of man-machine systems. The use of a language such as GPSS greatly simplifies the task of complex and extensive programming for a simulation system. However, computational problems are often encountered.

As a step further, it would be worthwhile to attempt a linkup between GPSS and FORTRAN so as to use the simulation capabilities of the former and the computational capabilities of the latter. Further still, an interactive CRT coupled display system could provide simultaneous interaction between the analyst and the system being simulated.

In addition much work remains to be done in order to refine the stress and success models, to add further concepts and interrelationships and to incorporate meaningful psychological data.

R E F E R E N C E S

1. Siegel, A.I., Wolf, J.J., Sorenson, R.T., "Evaluation of a One- or a Two- Operator System Evaluative Model through a Controlled Laboratory Test," Wayne, Pa., Applied Psychological Services.
 2. Martin, F.F., "Computer Modelling and Simulation," Wiley, New York, 1968.
 3. I de Sola Pool, "Simulating Social Systems," International Science and Technology, March 1964.
 4. Cartwright and Zander, "Group Dynamics," Harper and Row, New York.
 5. Siegel, A.I., Wolf, J.J., "Man-machine Simulation Models," Wiley Series in Human Factors, New York.
 6. Gagné, R.M., "Psychological Principles in System Development," Hold, Rinehart and Winston, New York.
 7. Shapiro and Rogers, "Prospects for Simulation and Simulators of Dynamic Systems," Macmillan and Co., London.
 8. Natrella, M.G., "Experimental Statistics," NBS Handbook 91 .
 9. Gagné, R.E., "On the Engineering use of Computers," Applied Mechanics Symposium, University of Waterloo, 1971 .
 10. Chapanis, A., "Men, machines and models," American Psychologist 1961, 16, 113- 131 .
-