

Simulink Application On Dynamic Modeling Of Biological Waste Water Treatment For Aerator Tank Case

Alban Kuriqi

Abstract: Environmental protection and water quality preservation is an import task for each person in the world. In this paper importance of water quality is discussed, in addition different waste water treatment processes are presented. Main objective of this paper is application of Simulink for dynamic modeling of biological treatment, especially concerning to the activated sludge processes (ASP). In connection with Simulink modeling different mathematical approach are presented and consider also during the simulation. Simulink modeling on Matlab is developed based on aerator tank model. Aerator model itself consists on movement of particles settled on bottom of the tank, by using air bubbling process. Several simulations are done for two different cases, dry weather and rain episode. Concerning to dry weather episode, equilibrium of biomass and organic matter is reached after long period (i.e. 200 days). While concerning to the rain episode there is a decrease of biomass and increase of organic matter, also it is notice a significant growth of bacteria's. Finally this model could be improved by considering a slow increase of flow rate.

Index Terms: Waste Water Treatment, Simulink, Aerator Tank, Rain Episode, Dry Weather, Organic Matter, Biomass.

1 INTRODUCTION

Water is one of the most important resources for human being, fauna and flora also, on the other hand preservation of the water quality is another challenges. In the past, construction and operation of sewer and sewage system has been driven by two main objectives: public hygiene and flooding prevention [1]. While last decades protection of environmental water has gained significant awareness from people, which is reflected also in different requirements and regulations [2], [3]. So, wastewater treatment is becoming more and more important especially in a highly populated area and industrialized world. Waste water contain significant amount of organic and inorganic matter. In terms of water quality, high attention should be given to the organic matter, especially to the nutrients (phosphorus, nitrogen) concentrations. High presences of nutrients in the water cause algae growth, oxygen depletion and other additional problems also. There are different treatment process, among them we can pick out biological treatment process, which accomplish sewage treatment and is one of the most economical and efficient. In connection with biological treatment, the activated sludge process (ASP) is one of the most often applied biological wastewater precaution technique [4], [5], [6]. This paper deals with dynamic modeling of ASP by using Matlab tools Simulink. Activated sludge models (ASMs) are generally accepted and consider as mathematical description of biological processes in the ASP reactors [7], [8]. Since awareness of public for protection of the environment is increased, importance and usage of modeling and simulation is increased also.

Modeling itself has significant importance, it is consider as substantial part of design and operation stage of waste water treatment process. Often, models used in practice can be classified as: conceptual, physical, empirical and mathematical [9], [10]. Before designing a waste water treatment plant, first step is conceptualization of the problem, and then mathematical model can be used for developing, operation and optimization of the waste water treatment plant. Usage of models is very promising in developing of advance tools with simple interface in order to understand interaction of different processes dealing with waste water treatment processes. There are several modeling approach and simulation tools developed for different purpose: research, industrial etc. Almost all these models and tools are developed based one different mathematical approach [11].

2 MATERILAS AND METHODS

2.1 Materials

Concerning to the parameters, those are obtained from waste water treatment plant which is built near the Hilaire river (Fig 1), with quality index is "Blue" (very good quality, index>80) following the SEQ-Eau nomenclature which is effective in France since the beginning of year 2000.

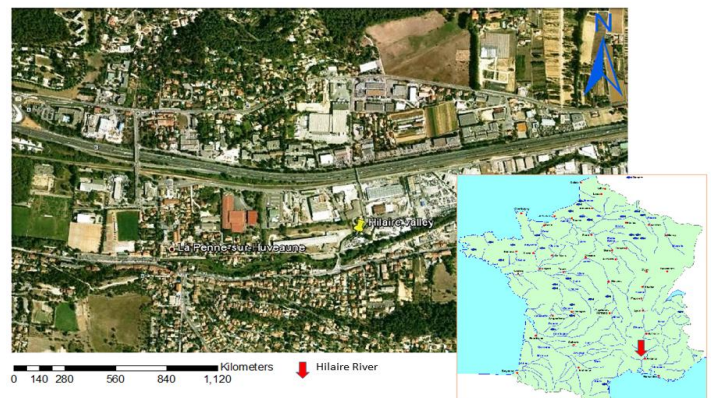

Fig.1. Location of Hilaire River

- Alban Kuriqi is currently working at Illyrian Consulting Engineers, Albania, PH-+355673078854.
- E-mail: albankuriqi@gmail.com

The discharge of waste water treatment plant in the natural environment must not disturb the ecological functions of the river. Indeed, this river has a good reputation for many activities such as fishing, recreational activities etc. The urban community takes a great advantage of this touristic attractiveness. The quality objective set by the project managers is a quality index > 60 (in regards of the SEQ-eau), which corresponds to a river declassification of one category, situation compatible with the downstream activities. We will now consider the dynamics of evolution of concentrations for a long period. All relevant parameters used in our Simulink modeling are shown in (Table 1).

Table 1. Parameters used in Simulink modeling

Parameters	Quantity	Units
O2	8	mg/l
DBO5	2	mg/l
DCO	10	mg/l
NH4+	0,3	mg/l
P _{total}	0.04	mg/l
MES	4	mg/l
QMNA5 Dry period	0.7	m3s-1
QMNA2 Rainfall period	2	2m3s-1
V	0.1	m.s-1
Y	0,7	Unit-less
μ _{max}	0,288	j-1
K _s	0,085	kg
X _a	3	g/l
b	0,01	j-1

2.2 Aerator tank model

A waste water treatment plant should be consider, also in mean time it should work as unit system where all processes and sub-processes are linked all together [12]. In aerator tank moving of settling materials is caused as result of air bubbling process which is a vigorous process, during this process entire reactor tank is assumed to be completely mixed [13]. The idea is to maintain suspended material in the wastewater by stirring or aeration. The suspended material contains bacteria, microorganisms, organic and inorganic particles. The organic material is used as the source of organic matter for the biomass (heterotrophic bacteria) and in that way, organic material is removed when biomass is produced. From the beginning, process was mainly used for removal of organic carbon substrates from the wastewater, which was easily obtained by rather simple methods. A schematic view of an activated sludge process is shown on the (Fig 2).

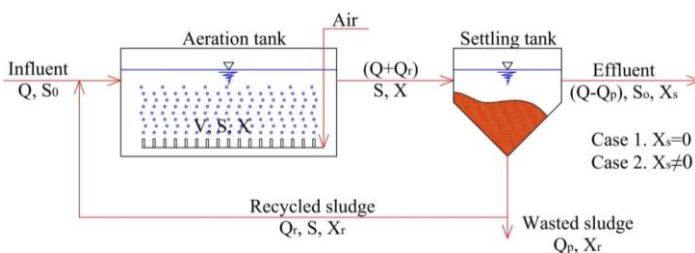

Fig. 2. Schematic representation of activated sludge process

In the aerator tank model, we consider the temporal evolution of the organic matter concentration (S), the biomass concentration (X) and the recirculated biomass concentration

(X_r). We assume an ideal flow in a complete mix-reactor, (i.e. the mixing is instantaneous). A second assumption is that input and output flow rates are equal, (i.e. the volume in the reactor is constant). The conceptual equation of the mass balance is: Variation of concentration along time = inflow – outflow + generation – loss (mortality)

$$\frac{dX(t)}{dt} = \frac{Q}{V} X_0 - \frac{Q}{V} X + \mu X(t) - K_d X(t) \tag{1}$$

Biomass concentration. For the biomass concentration (X), following the previous mass balance, we obtain:

Where:

- μ-is the growth rate of bacteria,
- K_d-the mortality coefficient of bacteria,
- X₀-the concentration of biomass at the entrance of the reactor,
- X (t)-the concentration of biomass at time (t),
- The growth rate (μ) depends on the availability of nutrients, mainly the concentration in organic matter (S). It is defined as a fraction of a maximal growth coefficient (μ_{max}), which is a constant, as:

$$\mu(S(t)) = \frac{S(t)}{S(t) + K_s} \mu_{max} \tag{2}$$

Sludge concentration. In this case, there is a loss of sludge by degradation but no generation. The loss depends on the concentration of biomass. The mass balance can be written as following:

$$\frac{dS(t)}{dt} = \frac{Q}{V} S_0 - \frac{Q}{V} S(t) - \frac{\mu}{Y} X(t) \tag{3}$$

Where:

- Y-is the synthesis yield coefficient; it gives the ratio of the produced mass of bacteria cells with the consumed mass of organic matter,
- S₀-the concentration of organic matter at the entrance of the reactor,
- S(t) -the concentration inside the reactor,
- $\frac{V}{Q}$ -is a time, which measures the time lapsed by the liquid in the reactor. It is called the hydraulic detention time (θ_H).

Recirculated biomass concentration. The mass balance of the recirculated biomass concentration (X_r) is the difference between the mass at the entrance and the mass at the output. If we only model the aerator (without settler), we have to include in this balance the loss of biomass with the part which is purged at the output of the settler, (X_p). The evolution of (X_r) can be written as following:

$$\frac{dX_r(t)}{dt} = \frac{Q + Q_r}{V} X - \frac{Q_r + Q_p}{V} X_r \tag{4}$$

2.3 Simulink modeling

To simulate the activated sludge process in a wastewater treatment plant, a dynamical model describing the process is needed. In this paper, the tool Simulink of Matlab software has been used to describe the activated sludge process [14], [15].The main objective of the work is to calibrate a dynamic

model that realistically describes the activated sludge and sedimentation processes. The activated sludge process is described by developing a model on Simulink as shown on (Fig 2).

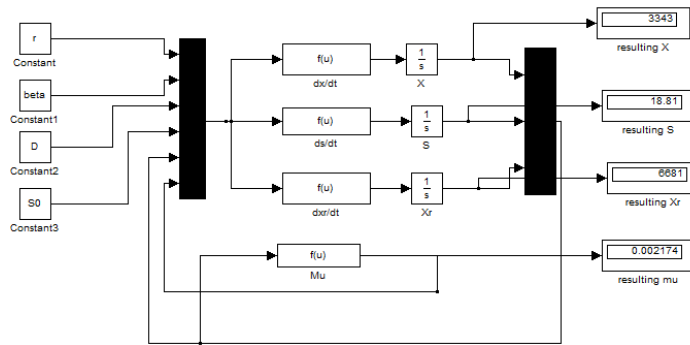

Fig. 1. ASP model developed with Simulink tool

In this model, considered parameters are:
 r-the ratio of recirculated concentration of biomass,
 β -the ratio of wasted concentration of biomass,
 $D = \frac{Q}{V} = \frac{1}{\theta_H}$ -the dilution factor and
 S_0 -the initial concentration of organic matter. The four equations used in this model are the ones given above.

3 RESULTS

Several simulation are performed for dry and rain episode, below are shown results for both cases. *Dry weather.* We have performed the computation for dry period and results obtained are shown graphically on (Fig 3). The model converges towards equilibrium states.

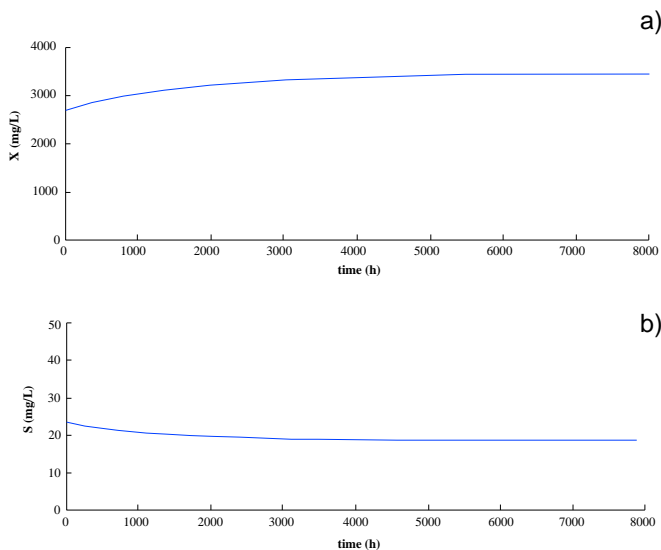

Fig. 2. Graphical representation of a) biomass and b) organic concentration evaluation during the time for dry period

Equilibrium is reached after approximately 5000h, (i.e. 208 day). The concentration of organic matter (S), reaches a final value equal around 19 mg/L. The biomass concentration (X) becomes equal to 3300 mg/L. In this paper, we imposed that the organic matter concentration at the output of the WWTP

was equal to 23mg/L. In this stationary model, we did not take into account a wasted liquid (with concentrations $X_p = \beta X$ and S). We notice that times to reach equilibrium are very long (200 day > 6 months!), we cannot explain it. Maybe we should take into account a mixing process in the aerator, which allows accelerating reactions. However, we have made the assumption of a complete mix-reactor and then reactions should be instantaneous. Another explanation could be that the evolution of concentrations is a kind of exponential. In a real plant, the equilibrium state is maybe not reach; however, final values of concentration should be very close to the equilibrium ones. *Rain episode.* We can play with this model and add a rain episode after a certain time. After 2000 steps of iteration (hours), we add a flow rate (Q_1) to the initial flow rate of wastewater (Q_0). If $Q = Q_e + Q_r$, the organic matter concentration entering in the station is equal to (S_0), the concentration of waste water, plus (S_1), the concentration of organic matter bring by storm water. The concentration of organic matter becomes:

$$S_0^r = \frac{S_0 Q_e + S_1 Q_r}{Q_e + Q_r} \tag{5}$$

We use a quantity of flow about $Q_1 = 190.8 \text{ m}^3/\text{h}$, while we know that (S_1) has a mean value of 100mg/L for a unitary network, to summary the model is built as following:

- For interval $< 2000 \text{ h}$, $S_0 = 285 \text{ mg/L}$, $Q = 252 \text{ m}^3/\text{h}$
- For interval $\geq 2000 \text{ h}$, $S_0 = S_{0r}$ and $Q = Q_e + Q_r$ with $Q_r = 191 \text{ m}^3/\text{h}$ and $S_r = 100 \text{ mg/L}$.

Results obtained concerning to the rain episode are shown graphically on (Figure 4).

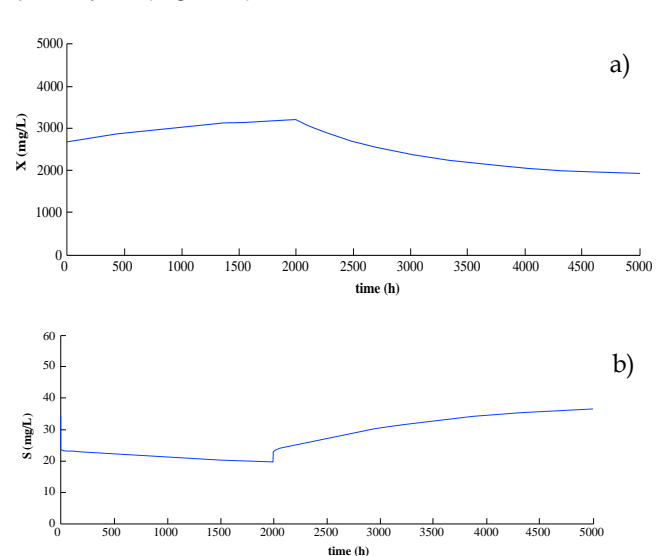

Fig. 3. Graphical representation of a) biomass and b) organic concentration evaluation during the time for rain period

After simulation is concluded that at $t = 2000 \text{ h}$, the organic matter concentration suddenly increases. It continues to increase, while there is a continuous input, brought by storm water. The biomass concentration decreases because the flow rate is increased and then biomass is diluted. Because of the

increase of (S), bacteria population is growing; however, it is not enough to compensate the dilution process. This model could be improved, considering a slow increase of flow rate.

CONCLUSIONS

In this paper is discussed dynamic modeling of biological waste water treatment process. As aforementioned, a Simulink tool is used for performing several simulations in order to see how the reaction of organic matter, biomass and bacteria population is. During the dry weather is notice a significant increase especially concerning to biomass and organic matter also. In addition for dry weather equilibrium state is reached after long period (i.e.200 days). Probably if we take into account mixing process in the reactor equilibrium could be reached for short period. While concerning to the simulation that is performed for rain episode as it is mentioned above, there is noticed decrease of biomass and significant increase of organic matter. In addition bacteria population is increase, which leads to deficiency of dilution process. For future research model could be improved by considering a slow increase of flow rate and other parameters also.

REFERENCES

- [1] Rauch, W., Bertrand-Krajewski, J. L., Krebs, P., Mark, O., Schilling, W., Schutze, M., & Vanrolleghem, P. A. (2002). Deterministic modelling of integrated urban drainage systems. *Water Science & Technology*, 45(3), 81-94.
- [2] Mulas, M., Baratti, R., & Skogestad, S. (2010). Controlled variables selection for a biological wastewater treatment process. In 8th IFAC Symposium on Dynamics and Control of Process Systems, Leuven.
- [3] Muraza, M., Mayo, A. W., & Norbert, J. (2013). Wetland Plant Dominance, Density and Biomass in Mara River Basin Wetland Upstream Of Lake Victoria in Tanzania. *International Journal of Scientific & Technology Research*, 2(12).
- [4] Chai, Q. (2008). Modeling, estimation, and control of biological wastewater treatment plants.
- [5] Harmand, J., Devisscher, M., & Steyer, J. P. (2002, July). Comparison of two advanced control strategies for monitoring of activated sludge processes. In *World Congress* (Vol. 15, No. 1, pp. 1461-1461).
- [6] Mulas, M. (2006). Modelling and control of activated sludge processes. *Università degli Studi di Cagliari*.
- [7] Henze, M., Gujer, W., Mino, T., & Van Loosedrecht, M. (2006). Activated sludge models ASM1, ASM2, ASM2d and ASM3.
- [8] Gernaey, K. V., van Loosedrecht, M., Henze, M., Lind, M., & Jørgensen, S. B. (2004). Activated sludge wastewater treatment plant modelling and simulation: state of the art. *Environmental Modelling & Software*, 19(9), 763-783.
- [9] Vanhooren, H., Meirlaen, J., Amerlinck, Y., Claeys, F., Vangheluwe, H., & Vanrolleghem, P. (2003). WEST: modelling biological wastewater treatment. *Journal of Hydroinformatics*, 5, 27-50.
- [10] Noykova, N., Müller, T. G., Gyllenberg, M., & Timmer, J. (2002). Quantitative analyses of anaerobic wastewater treatment processes: identifiability and parameter estimation. *Biotechnology and bioengineering*, 78(1), 89-103.
- [11] Morgenroth, E., Arvin, E., & Vanrolleghem, P. (2002). The use of mathematical models in teaching wastewater treatment engineering. *Water Science & Technology*, 45(6), 229-233.
- [12] Rosen, C., Vrecko, D., Gernaey, K. V., Pons, M. N., & Jeppsson, U. (2006). Implementing ADM 1 for plant-wide benchmark simulations in Matlab/Simulink. *Water Science & Technology*, 54(4), 11-19.
- [13] Wik, T. E., Lindén, B. T., & Wramner, P. I. (2009). Integrated dynamic aquaculture and wastewater treatment modelling for recirculating aquaculture systems. *Aquaculture*, 287(3), 361-370.
- [14] Rosen, C., Vrecko, D., Gernaey, K. V., Pons, M. N., & Jeppsson, U. (2006). Implementing ADM 1 for plant-wide benchmark simulations in Matlab/Simulink. *Water Science & Technology*, 54(4), 11-19.
- [15] Vrecko, D., Gernaey, K. V., Rosen, C., & Jeppsson, U. (2006). Benchmark simulation model No 2 in Matlab-Simulink: towards plant-wide WWTP control strategy evaluation (Vol. 54, No. 8, pp. 65-72).