

NASA Technical Memorandum 106456

5-25-94
E6834
Army Research Laboratory
Technical Report ARL-TR-10

Simultaneous Pressure Measurement and High-Speed Photography Study of Cavitation in a Dynamically Loaded Journal Bearing

D.C. Sun
*State University of New York at Binghamton
Binghamton, New York*

David E. Brewe
*Vehicle Propulsion Directorate
U.S. Army Research Laboratory
Lewis Research Center
Cleveland, Ohio*

and

Philip B. Abel
*Lewis Research Center
Cleveland, Ohio*

Prepared for the ASME/STLE Tribology Conference
cosponsored by the American Society of Mechanical Engineers and the Society of
Tribologists and Lubrication Engineers

NASA

U.S. ARMY
ARL
RESEARCH LABORATORY

SIMULTANEOUS PRESSURE MEASUREMENT AND HIGH-SPEED PHOTOGRAPHY STUDY
OF CAVITATION IN A DYNAMICALLY LOADED JOURNAL BEARING

D.C. Sun*

State University of New York at Binghamton
Department of Mechanical and Industrial Engineering
Binghamton, New York 13902-6000

David E. Brewé*

Vehicle Propulsion Directorate
U.S. Army Research Laboratory
Lewis Research Center
Cleveland, Ohio 44135-3191

and

Phillip B. Abel

National Aeronautics and Space Administration
Lewis Research Center
Cleveland, Ohio 44135-3191

SUMMARY

Cavitation of the oil film in a dynamically loaded journal bearing was studied using high-speed photography and pressure measurement simultaneously. Comparison of the visual and pressure data provided considerable insight into the occurrence and nonoccurrence of cavitation. It was found that (1) for the submerged journal bearing, cavitation typically occurred in the form of one bubble with the pressure in the cavitation bubble close to the absolute zero; and (2) for cavitation-producing operating conditions, cavitation did not always occur; with the oil film then supporting a tensile stress.

INTRODUCTION

Cavitation of the liquid lubricant film in a journal bearing affects bearing performance significantly. For stationary cavitation (resulting from steady bearing loads), the phenomenon is reasonably well understood (refs. 1 and 2). The latter reference also presented some visual results on the inception and development of the cavity during the transient period of bearing startup. For dynamic cavitation (resulting from unsteady bearing loads), many aspects of the phenomenon remain to be clarified. Unresolved questions include: What are the criteria for the onset of dynamic cavitation? What are the contents of a cavitation bubble? Can the cavitation bubble(s) be clearly separated from the full film region, or are they so numerous and thoroughly mingled with the liquid that the film should be treated as a two-phase fluid? These and other questions motivated many studies. These studies were briefly reviewed in reference 3, where the cavitation in a dynamically loaded journal bearing was studied with high-speed photography.

A unique feature of the work of Sun and Brewé (ref. 3) was that the bearing test rig could produce noncentered whirl, i.e., the journal axis could be displaced from the axis about which the sleeve whirled to produce desired static eccentricity values. In this way cavitation could be made to occur on one side of the

*Member ASME.

bearing circumference, and the entire life of a cavitation bubble could be studied. A main result of that work was that only the one-region cavitation pattern, rather than a well-mixed two-phase fluid of oil and air, was observed. An unsettling experience gained in the work was that producing cavitation was unexpectedly difficult, though a small bearing clearance, a large eccentricity, and/or a high whirl speed generally favored its occurrence.

To shed some light on the question of bubble contents, the characteristic time of filling a void with the vapor of the surrounding liquid, and one of filling the void by diffusion of the dissolved gas in the liquid, were derived (ref. 4). It was found that the evaporation time was much shorter, and the diffusion time much longer, than the characteristic time of the dynamic operation of oil film bearings. This suggested that the cavitation bubble would be filled with oil vapor but not with air that came out of the solution. This then implied that if the cavitation bubble contained air, the air must be the entrained air.

To further resolve the mystery of dynamic cavitation, it was deemed desirable to determine the pressure level in the cavitation region. Hence, the present investigation was conducted. The bearing test rig used earlier (ref. 3) was modified to allow simultaneous visual study and pressure measurement. As a result of the modifications, the journal was restricted from rotation during the measurement. Hence, the case investigated was one of a fixed nonrotating journal inside an orbiting but nonrotating sleeve.

The pressure field in dynamically loaded journal bearings has been measured by many investigators. Hibner and Bansal (ref. 5), San Andres and Vance (ref. 6.), and Jung et al. (refs. 7 and 8) measured it with the interest of obtaining the dynamic bearing forces. The former two authors aimed their investigation at the possibility that cavitation might make the lubricant a compressible fluid. The latter authors' emphasis was the inertia effect of flow. None of these works included visual studies. Zeidan and Vance (ref. 9) conducted both pressure measurement and visual study, but the two sets of results were obtained with different bearing housings (one made of steel, the other made of clear acrylic). Ku and Tichy (ref. 10) supplemented the pressure measurement with a film thickness study using a fiber optic probe which was installed 90° from the pressure transducer. All the above-mentioned works dealt with the case of controlled-orbit centered whirl and did not emphatically address the issue of subambient pressure in the oil film, except that Ku and Tichy noted that the pressure in the cavity was nearly constant and equal to the absolute zero.

Natsumeda and Someya (ref. 11) measured the pressure field in the case of controlled loads. Their interest was to develop the appropriate boundary conditions for solving the Reynolds equation. For both the cases of steady and unsteady loads, they measured a sharp tensile stress dent in the oil film right downstream of the pressure peak. In another work from the same school (ref. 12) the authors included also a visual study. Since the pressure measurement and visual study were performed on different bearing sleeves, correlation of the two sets of results was not attempted. The existence of tensile stress in the oil film in a steadily loaded journal bearing was reported earlier by Dyer and Reason (ref. 13).

The present study differs from previous efforts in the literature in that the pressure measurement and visual study were conducted in the same bearing, at the same location, and simultaneously. The pressure transducers were positioned within the field of view of the movie camera. As the cavitation bubble swept over the transducers, its entire development life was observed and documented in a movie, while the pressure variation was registered by the transducers. Comparison of the visual and pressure data provided considerable insight into the occurrence and nonoccurrence of cavitation. Details of the work are described in this paper.

NOMENCLATURE

- c radial clearance
- D journal diameter

e_d	whirl amplitude of sleeve about the sleeve-shaft center
e_s	distance between the journal center and the sleeve-shaft center
L	journal length
O	sleeve-shaft center (fig. 5)
O_b	sleeve center (fig. 5)
O_j	journal center (fig. 5)
p	pressure
p_a	ambient pressure
t	time
ϵ_d	dynamic eccentricity, e_d/c
ϵ_s	static eccentricity, e_s/c
θ	circumferential coordinate (fig. 5)
ω_b	whirl speed of sleeve

APPARATUS AND DATA ACQUISITION

A schematic of the bearing test rig is shown in figure 1. The rig consisted mainly of a journal and a sleeve. The sleeve support structure was fixed to a steel base; the journal support structure was anchored to a cross slide, which was fixed to the base. The base was clamped down on a sturdy, flat machine table whose level was adjustable. Details on the alignment of the rig, the method of generating the static and dynamic eccentricities, the transparent sleeve and photographic setup, the lubricant supply and sealing of the rig, etc. are as described in reference 3. The modifications made to accommodate the pressure measurement are as follows:

The Journal and Its Supporting Shaft

A new steel journal and journal shaft were made. The journal was hollow so that pressure transducers could be mounted from inside. The hollow space inside the journal was vented to the test chamber through openings cut on one end of the journal. The journal had a length-to-diameter ratio (L/D) of 0.5, and an outside diameter (D) of 84.58 mm, which resulted in a radial clearance (c) of 0.21 mm.

A gallery was cut through the axis of the journal shaft for transducer wires to be led out of the test chamber. The gallery was sealed with silicone rubber to prevent lubricant leakage. Because of the wiring arrangement, tests could not be run with the journal in rotation, but the journal could be rotated and fixed in any angular position.

Pressure Transducers

Two Kulite strain-gage type miniature absolute pressure transducers, built to NASA Specification U-100, were used. The dimensions of the transducers are shown in figure 2(a). The transducers had a full-scale pressure of 100 psi (689.4 kPa) with 3X overload capability; a nominal full-scale output (FSO) of 100 mV under 10 V excitation; 0.03 percent FSO nonrepeatability; 0.01 percent FSO hysteresis error; 0.09 percent FSO nonlinearity error; and a natural frequency of 240 kHz. When used in conjunction with a multimeter (and with the signals

amplified 10 times) to measure a steady-state pressure, the fluctuations of the readings were within 0.1 mV, which corresponded to an uncertainty of 0.01 psi (68.9 Pa).

The transducers were shop calibrated using 200 milli torr (26.7 Pa) manifold pressure as the absolute zero. This pressure was in the level of the vapor pressure at room temperature of the DEXRON II automatic transmission fluid used in the experiment. Hence, one should not expect these transducers to be capable of resolving the vapor pressure.

Discussions with the transducer manufacturer revealed that the absolute pressure transducer had the capability of measuring tension. This was because the structure of the absolute transducer was essentially the same as that of the differential transducer, except that in the former, the reference chamber under the diaphragm was evacuated and sealed, whereas in the latter the reference chamber was vented to the ambient atmosphere. Since the differential transducer could measure vacuum (negative gauge pressure), the same principle allowed the absolute transducer to measure tension, provided the fluid adhered to the diaphragm. However, the absolute transducers were not calibrated for tension; their tension readings could only be interpreted through extrapolation of the pressure calibration curves.

Transducer Mounting Plugs

Two brass plugs were made to house the transducers. The dimensions of the plugs are shown in figure 2(b). The plugs were press fit into the journal wall, then ground with the journal so as to minimize their interference of the cylindrical journal surface. The selection of the thickness of the plug cap and the size of the pressure sensing hole was a compromise between conflicting requirements: (1) The cap should be as thin as possible while still maintaining rigidity under the fluctuating pressure. (2) The hole should be as small as possible yet without causing excessive delay of the pressure signal. With the dimensions shown in figure 2(b), the error in pressure measurement due to the presence of the plugs was estimated¹ to be less than 150 Pa.

The two plugs were installed at the same circumferential location, one at the midplane of the journal and the other halfway between the midplane and the edge. Figure 3 shows the journal with the transducers installed as viewed from the side of the movie camera. The joints between the transducers and the plugs were sealed with vacuum grease and O-rings. Air tightness was checked under a vacuum of 10^{-5} torr.

The cavities in the plugs above the transducers were filled with liquid lubricant before the experiment. The journal, with the transducers installed, was placed in a desiccator and submerged in the liquid lubricant. The pressure in the desiccator was first pumped down to 66.7 Pa to evacuate the cavities. Then, the pressure was gradually returned to atmosphere and the liquid allowed to enter the cavities. The process was repeated several times to make sure that the cavities were completely filled with the liquid. Once filled, the liquid remained in the cavities even when the transducers were placed facing downward, due to surface tension.

Instrumentation

In addition to the 60-tooth gear disk used to monitor the whirl speed (ω_b) of the sleeve, which was described in reference 3, another disk with a single gear-tooth was also mounted on the sleeve-shaft to actuate a

¹This estimate was based on the pressure difference required to pass a given flow rate through an orifice or a capillary. The flow rate was the volume created by the estimated deflection of the transducer diaphragm divided by a required response time. The orifice flow formula was found to always yield a smaller pressure difference. Hence, the capillary flow formula was used.

magnetic pickup once per revolution. This one-tooth disk was used to mark the minimum oil film thickness occurring at $\theta = 0$,² a position that appeared in the middle of the movie camera's view (fig. 5).

Excitation and signal conditioning for the transducers were provided by conventional bridge balance units. The output signals were amplified 10 times and then displayed on a dual-beam oscilloscope and were synchronized with the whirling sleeve by the one-pulse-per-revolution signal. Figure 4 shows the instrumentation arrangement.

Data Acquisition

A Data Translation DT2805 board, along with a DT707 terminal panel, were used in conjunction with an IBM PC/XT to convert the pressure signals into digital data and store them in the computer. The board was programmed using BASIC language to perform these operations. The gain of the board was set such that its error in reading the pressure magnitude was 0.05 psi (344.5 Pa).

Three whirl speeds, viz., 600 r/min (62.8 rad/s), 1500 r/min (157.1 rad/s), and 2400 r/min (251.3 rad/s), were used in the experiment. For the two lower speeds, three channels of the board were used to read the one-pulse-per-revolution signal and the output signals of the two pressure transducers, respectively. The channels, each picking up 72 data per revolution of whirl, were activated sequentially. As a result, the offset in timing between any two successive signals was 1.67° . At the highest speed, the data capture rate of the board only allowed the use of two channels per run (one channel for the one-pulse-per-revolution signal and another channel for one transducer signal). Hence, the data of the two transducers were obtained in separate runs. These pressure data were synchronized using the one-pulse-per-revolution signal. The offset in timing between the two transducer signals in this case was due to the uncertainty in synchronization, which was less than 2.5° .

In the experiment the sleeve always whirled in the clockwise direction as viewed from the sleeve side. Figure 5 shows the relative positions of the journal and sleeve centers and the coordinate system. For the case of centered whirl, the pressure was measured with the transducers placed at $\theta = 0$, and presented in a two-dimensional plot of pressure versus time. For the case of noncentered whirl the same run was repeated 16 times, each time with the transducers placed at a different θ location (22.5° apart). The 16 pressure traces were lined up using the one-pulse-per-revolution signal. The pressure field (as a function of θ and t) so obtained was plotted using a three-dimensional graphics package.

RESULTS AND DISCUSSION

It was found during the tests that various components of the test rig suffered excessive deflections. With the use of an eddy-current type proximeter probe, the following data were obtained: At an amplitude set for $e_d = 0.21$ mm, the actual whirl amplitude of the sleeve was only 0.127 to 0.140 mm; that of the sleeve mounting plate was 0.153 to 0.178 mm. Meanwhile, the sleeve support structure oscillated with an amplitude of 0.0127 mm; the journal support structure with an amplitude of 0.0254 to 0.0330 mm. These large deviations from original settings were probably due to wear of the bearings and dynamic eccentricity device after several summers of extensive running. Unfortunately, the time constraints of the project did not permit rebuilding the rig. Hence, the nominally set eccentricity values contained a large margin of uncertainty.

²To indicate the same event in the movie, an ink mark was made on the dynamic eccentricity device (fig. 1) and another on the nonrotating sleeve. When the two marks lined up, the minimum oil film thickness occurred at $\theta = 0$. Since the camera speed was known, one could then also determine the angle of whirl by counting the frames.

Another source of error was that the journal surface in the neighborhood of the pressure transducers deviated from the true cylindrical shape. The region of flattening extended 30° in each direction from the transducers, with a dip of 0.084 mm at the center transducer and 0.127 mm at the side transducer. This defect in surface shape undoubtedly caused a significant reduction of the pressure magnitude. The error was discovered toward the end of the project and was not corrected. Both the deflection of the rig and the error in the surface shape rendered the measured results only illustrative.

Visual Study

The visual study confirmed the main results reported by Sun and Brewe (ref. 3), viz., (1) in both the cases of centered and noncentered whirl only the one-region cavitation pattern was observed; and (2) high whirl speeds and large eccentricities favored the occurrence of cavitation. There were always air bubbles present in the test chamber due to imperfect venting. These bubbles generally moved in and out of the bearing clearance following the pressure cycles. However, at high speeds the pressure variation was so rapid that these bubbles became trapped in the bearing clearance. The presence of these trapped air bubbles contributed to the increased size of the cavitation region.

These observations indicated that the basic form of cavitation was the one-region pattern, and its occurrence was related to the presence of entrained air bubbles. If adequate leak paths were not available for air to be continually entrained into the bearing clearance, then the cavitated oil film would not develop to a well-mixed two-phase fluid.

While the cavitation was found to be one region, there always appeared to be some complicated structures in it. A close observation of these structures indicated that they were composed of the residual filaments of the fractured oil film.

High-speed (2000 frames per second) movies were taken for several cases of centered and noncentered whirl along with the pressure measurement. Correlations between the two sets of results will be discussed below.

Pressure Measurement

A sample pressure trace in the case of centered whirl is shown in figure 6. The whirl amplitude was statistically set to be so large that the sleeve and journal surfaces contacted each other. Hence, the nominal eccentricity value was $\epsilon_d = 1$. The measured pressure was considerably lower than expected, however. This was most likely due to the flattening of the journal surface surrounding the pressure transducers. An error analysis of this surface defect is not available. If the amount of flattening could be used as a sort of effective clearance, then the effective eccentricity value might be taken as $\epsilon_d = 0.4$. A sample three-dimensional plot of the center-line pressure in the case of noncentered whirl is shown in figure 7. Note that the plot consists of 16 pressure traces obtained with the center transducer positioned successively at 22.5° intervals. The static eccentricity in this case was set at $\epsilon_s = 0.5$; the whirl amplitude was again set with the sleeve and journal surfaces in contact. Hence, the nominal dynamic eccentricity was $\epsilon_d = 0.5$.

The flat segment on any pressure curve in figures 6 and 7 corresponded to the cavitation region observed visually. Thus, the measurement revealed that the pressure in the cavitation region was very close to the absolute zero. As described by Sun and Brewe (ref. 4), the evaporation time of oil was much shorter than the time of dynamic operation; hence, oil vapor would always be present in the cavitation region. But the transducers were not capable of distinguishing the low vapor pressure from zero. It was also observed that air bubbles in the test

chamber sometimes joined the cavitation region. Suppose an air bubble was initially 1 mm in radius at the atmospheric pressure, and after merging with the cavitation bubble its air contents were distributed over a region 10 mm in radius. By the isothermal ideal gas relation the pressure after merging would be less than 1 percent of the atmospheric pressure, which would be in the same order of magnitude as the instrumentation error. Hence, whether the cavitation region contained vapor or air, its pressure would be close to the absolute zero.

The authors adapted both the long and short bearing solutions to the experimental conditions, and predicted that, at $\theta = 0$, the pressure versus time curve should start (at $t = 0$) with a negative slope and from the ambient pressure value.³ The measured pressure curves all displayed a large lead relative to these conventional theories. A part of this phase shift was due to an alignment error: It was found by examining the pressure traces in the case of noncentered whirl that the minimum-minimum film thickness was actually located near $\theta = 337.5^\circ$ instead of $\theta = 0$. The remaining part of the phase shift might be caused by the inertia effect of a rotating system subject to deflections.

Presence of Tensile Stress in the Oil Film

It was found that the oil could sustain tension. For a given operating condition, if cavitation occurred, the pressure in the cavitation region was nearly the absolute zero, as previously described. However, cavitation sometimes did not occur and the pressure measured was negative, i.e., the oil film was under a tensile stress. Which result would occur was not predictable, but once cavitation occurred or was absent, the behavior persisted. The phenomenon might be crucially dependent on the availability of cavitation nuclei in the oil. Where nuclei were present, the tensile strength of the oil was annihilated and cavitation occurred; where they were not, the oil might be able to withstand the tensile stress and remain intact. Since the oil used in this experiment was reasonably clean, the cavitation nuclei were most likely the small air bubbles not thoroughly vented out of the test chamber.

In figures 8 to 12, the photographs in parts (a) were extracted from the movies taken when the pressure variations shown in parts (b) were measured. The setting of the static and dynamic eccentricities in these figures (as well as in fig. 13) was identical to that in figure 7. In figure 8(a) the pear-shaped cavitation bubble went through its entire life in the upper half of the camera's view. Since the cavitation region cleared the pressure transducers, the latter recorded tensile stresses during part of the whirl cycle, as shown in figure 8(b). Sometimes, however, the cavitation bubble also appeared in the middle of the camera's view (fig. 9(a)). In this case the bubble only swept over the center transducer, as a result only the side transducer registered a tensile stress, as shown in figure 9(b). A similar situation occurred at a higher whirl speed (fig. 10). In this case the center transducer experienced the cavitation bubble, but the pressure in the bubble was clearly above the absolute zero level. This was caused by the fact that, at a higher whirl speed, more air bubbles joined the cavitation region resulting in a pressure visibly higher than the vapor pressure of oil.

The photographs in figures 11(a) and 12(a) were extracted from a movie where the transducers were placed at $\theta = 315^\circ$. In the case of figure 11 the side transducer did not experience cavitation and it registered a tensile stress when its neighbor, the center transducer, was cavitated. As the cavitation region spread, its influence began to reach the side transducer. In the situation shown in figure 12, the side transducer might be described as at the verge of becoming cavitated.

As mentioned earlier, the minimum-minimum film thickness was found to be near $\theta = 337.5^\circ$. It turned out that the measured tensile stresses were also the largest here. Figure 13 shows that the transducers at this

³The ambient pressure fluctuated between 14.3 and 14.5 psi during the period of this study. In presenting the results, the measured pressure in an experiment was normalized by the ambient pressure measured during that experiment.

location did not experience cavitation at any of the three whirl speeds. The largest tensile stress occurred at the center transducer at $\omega_0 = 251.3$ rad/s; its magnitude was almost 140 kPa.

Because of the deflection of the rig and the error in the journal surface shape, one cannot lend much credence to the accuracy of the pressure measurement. However, a convincing picture was formed by the combined pressure measurement and visual study, viz., a tensile stress existed in the oil film at a location where a cavitation bubble would otherwise appear.

Tensile stresses were found in liquid lubricant films by several investigators. An excellent review of this topic was given in reference 13. The recorded magnitudes of the tensile stresses were also high. For instance, Dyer and Reason (ref. 13) measured a tensile stress of 0.74 MPa in a steadily loaded journal bearing; Natsumeda and Someya (ref. 11) measured 1.2 MPa in a dynamically loaded journal bearing. However, Dyer and Reason pointed out that the measured magnitudes of the tensile stress, as well as the nonobservation of it, in previous attempts were probably limited by the pressure-measuring configurations. Thus, while the actual tensile stress a liquid can withstand might depend on the population of cavitation nuclei the liquid contains, the measurement of the tensile stress could further depend on the instrumentation. Based on their measured data from a steadily loaded journal bearing, Dyer and Reason (ref. 13) derived a criterion for the existence of tensile stresses. It is not clear whether the criterion would be equally applicable to the case of dynamically loaded journal bearings. Natsumeda and Someya (ref. 11) attempted to explain the presence of tension by developing a hydrodynamic lubrication theory of two-phase fluid. From the results obtained in this study, it seems clear that the presence of tensile stresses is associated more with the absence of cavitation than with an excess of cavitation (such that a two-phase fluid is formed).

SUMMARY OF RESULTS

Cavitation of the oil film in a dynamically loaded journal bearing was studied using high-speed photography and pressure measurement. The visual study and pressure measurement were conducted in the same bearing, at the same location, and simultaneously. Correlation of the two sets of results revealed the following:

1. For a given operating condition, if cavitation appeared, it was typically in the form of one bubble, which encompassed the residual filaments of the fractured oil film. The cavitation bubble contained oil vapor and most likely also air. The pressure in the cavitation bubble was close to the absolute zero.
2. Cavitation sometimes did not appear for the same operating condition, and the pressure measurement revealed that the oil film was under a tensile stress. The appearance or absence of cavitation was not predictable, but was quite persistent once a type of behavior occurred.
3. The appearance or absence of cavitation might be crucially dependent on the availability of cavitation nuclei in the oil. Where nuclei were not present, the oil could sustain tension without cavitation up to its tensile strength. Where nuclei were present, the tensile strength of the oil was annihilated and cavitation occurred. The cavitation nuclei in the experiment were most likely the small air bubbles not thoroughly vented out of the test chamber.

ACKNOWLEDGMENTS

The authors would like to thank Messrs. Thomas J. Toddy, David J. Clinton, Jay C. Owens, and Christopher Teodecki for their assistance in this work.

REFERENCES

1. Dowson, D.; and Taylor, C.M.: Cavitation in Bearings. *Ann. Rev. Fluid Mech.*, vol. 11, 1979, pp. 35–66.
2. Braun, M.J.; and Hendricks, R.C.: An Experimental Investigation of the Vaporous/Gaseous Cavity Characteristics of an Eccentric Journal Bearing. *ASLE Trans.*, vol. 27, 1984, pp. 1–14.
3. Sun, D.C.; and Brewe, D.E.: A High-Speed Photography Study of Cavitation in a Dynamically Loaded Journal Bearing. *ASME J. Trib.*, vol. 113, 1991, pp. 287–294.
4. Sun, D.C.; and Brewe, D.E.: Two Reference Time Scales for Studying the Dynamic Cavitation of Liquid Films. *ASME J. Trib.*, vol. 114, 1992, pp. 612–615.
5. Hibner, D.H.; and Bansal, P.N.: Effects of Fluid Compressibility on Viscous Damper Characteristics. Proceedings, Conference on the Stability and Dynamic Response of Rotors With Squeeze Film Bearings, U.S. Army Research Office, 1979, pp. 116–132.
6. San Andres, L.A.; and Vance, J.M.: Experimental Measurement of the Dynamic Pressure Distribution in a Squeeze-Film Bearing Damper Executing Circular-Centered Orbit. *STLE Trib. Trans.*, vol. 30, 1987, pp. 373–383.
7. Jung, S.Y., San Andres, L.A.; and Vance, J.M.: Measurements of Pressure Distributions and Force Coefficients in a Squeeze Film Damper. Part I: Fully Open Ended Configuration. *STLE Trib. Trans.*, vol. 34, 1991, pp. 375–382.
8. Jung, S.Y., San Andres, L.A.; and Vance, J.M.: Measurements of Pressure Distributions and Force Coefficients in a Squeeze Film Damper. Part II: Partially Sealed Configuration. *STLE Trib. Trans.*, vol. 34, 1991, pp. 383–388.
9. Zeidan, F.Y.; and Vance, J.M.: Cavitation Leading to a Two Phase Fluid in a Squeeze Film Damper Bearing. *STLE Trib. Trans.*, vol. 32, 1989, pp. 100–104.
10. Ku, C.P.; and Tichy, J.A.: An Experimental and Theoretical Study of Cavitation in a Finite Submerged Squeeze Film Damper. *ASME J. Trib.*, vol. 112, 1990, pp. 725–733.
11. Natsumeda, S.; and Someya, T.: Negative Pressures in Statistically and Dynamically Loaded Journal Bearings. Paper III(ii), Proceedings of Leeds-Lyon Symposium on Tribology, Leeds, England, 1986, pp. 65–72.
12. Kawase, T.; and Someya, T.: An Investigation Into the Oil Film Pressure Distribution in Dynamically Loaded Journal Bearings. Proceedings, 4th European Tribology Congress, vol. II, Ecully, France, Sept. 9–12, 1985.
13. Dyer, D.; and Reason, B.R.: A Study of Tensile Stresses in a Journal-Bearing Oil Film. *J. Mech. Eng. Sci.*, vol. 18, 1976, pp. 46–52.

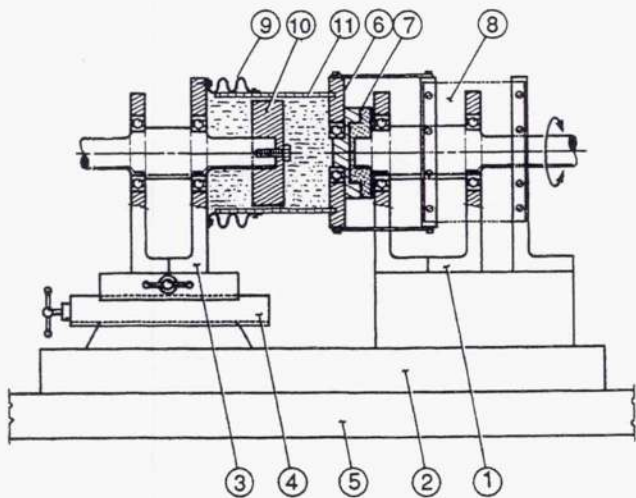

- | | |
|--------------------------------|--------------------------|
| 1. Sleeve support structure | 2. Steel base |
| 3. Journal support structure | 4. Cross slide |
| 5. Machine table | 6. Sleeve mounting plate |
| 7. Dynamic eccentricity device | 8. Flexure mechanism |
| 9. Bellow seal | 10. Journal |
| 11. Sleeve | |

Figure 1.—Schematic of test apparatus.

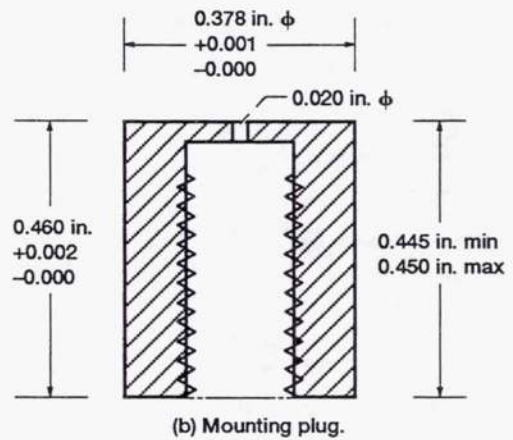
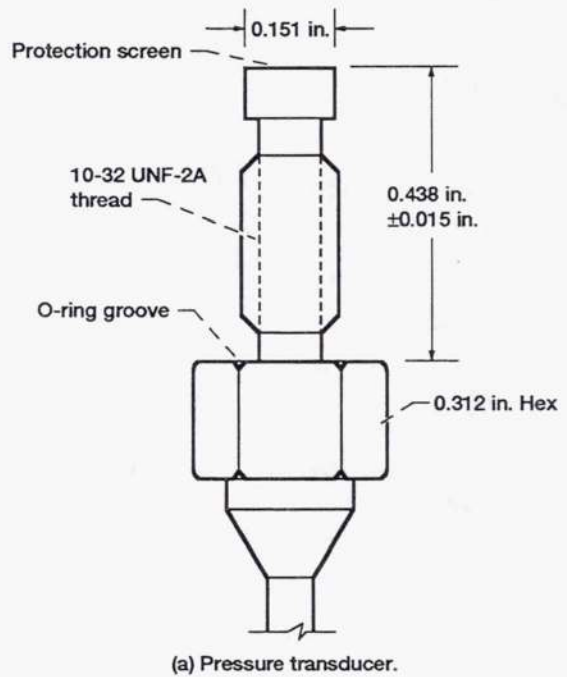

Figure 2.—Pressure transducer and its mounting plug.

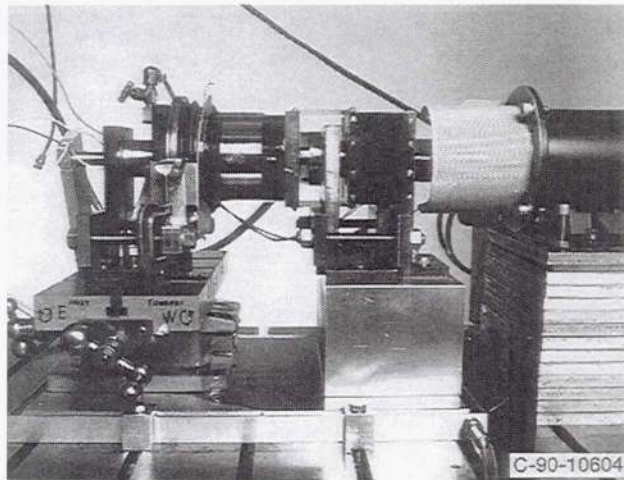

Figure 3.—A close-up view of the test rig.

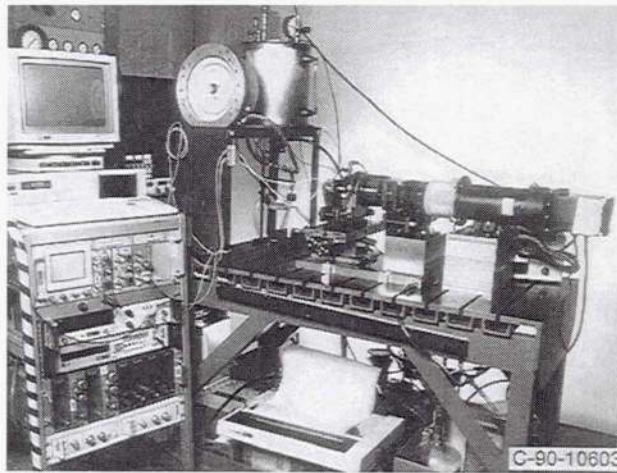

Figure 4.—Arrangement of instrumentation.

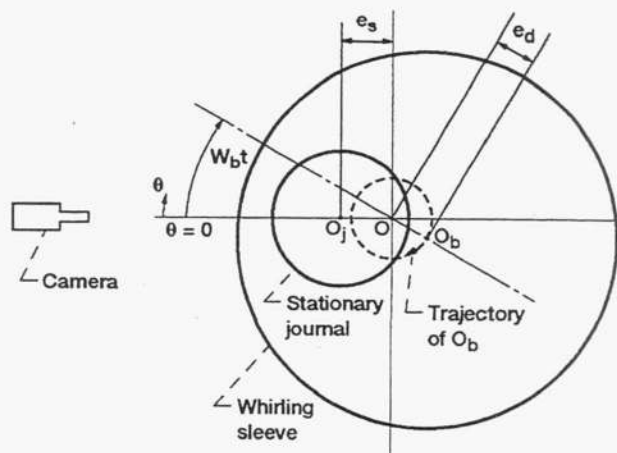

Figure 5.—Direction of whirl as viewed from the sleeve side.

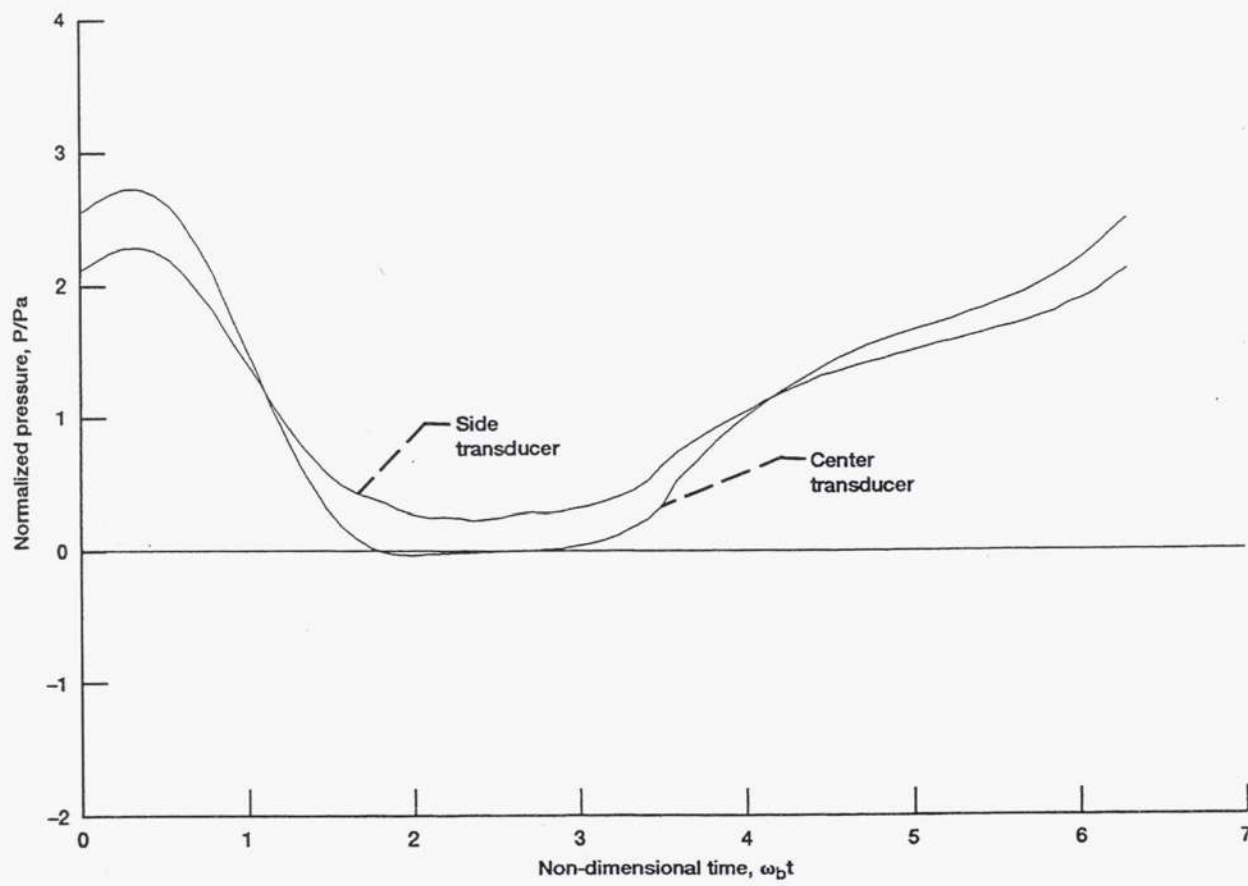

Figure 6.—Pressure versus time in the case of centered whirl, (transducers at $\theta = 0$, $\omega_b = 251.3$ rad/s).

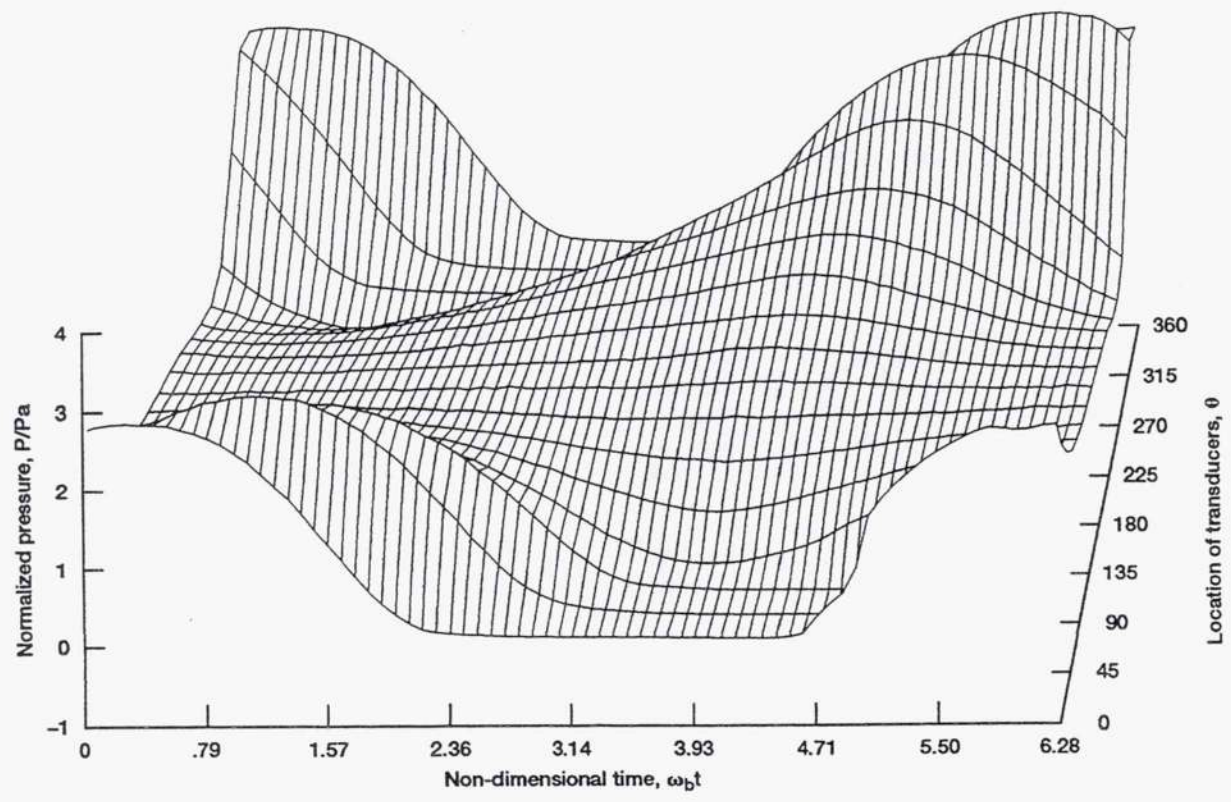
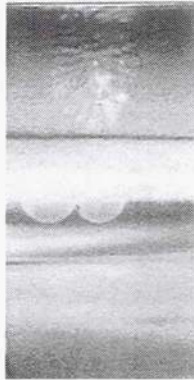
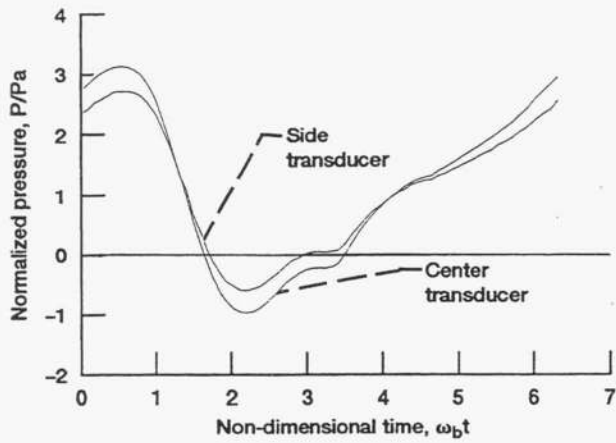

Figure 7.—Centerline pressure in the case of noncentered whirl, ($\omega_b = 251.3$ rad/s).



(a) Photograph of cavitation bubble.



(b) Pressure variation.

Figure 8.—Cavitation bubble and simultaneously measured pressure, (transducers at $\theta = 0$ deg, $\omega_b = 62.8$ rad/s).

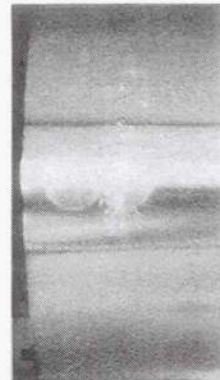

(a) Photograph of cavitation bubble.

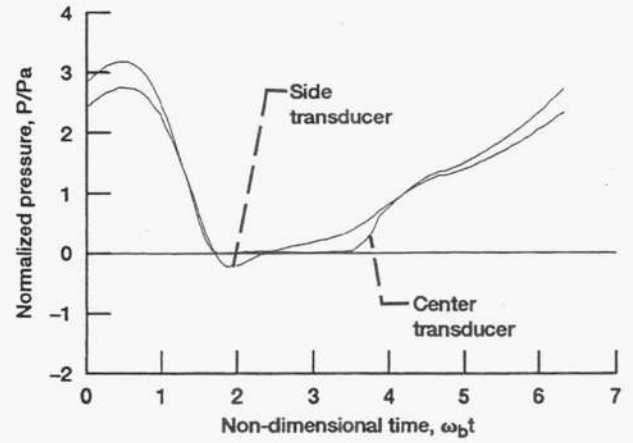

(b) Pressure variation.

Figure 9.—Cavitation bubble and simultaneously measured pressure, (transducers at $\theta = 0$ deg, $\omega_b = 62.8$ rad/s).

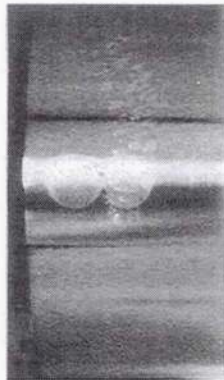

(a) Photograph of cavitation bubble.

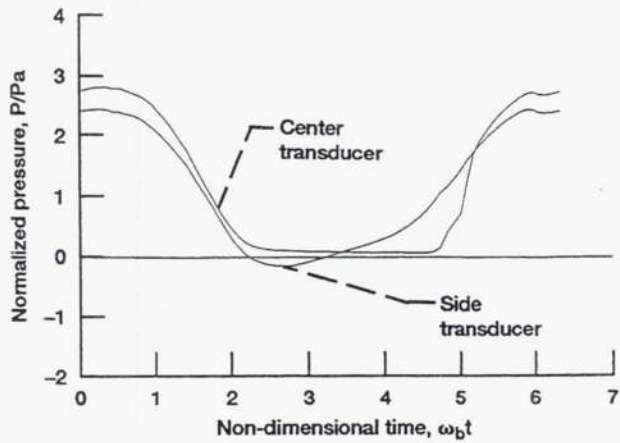

(b) Pressure variation.

Figure 10.—Cavitation bubble and simultaneously measured pressure, (transducers at $\theta = 0$ deg, $\omega_b = 251.3$ rad/s).

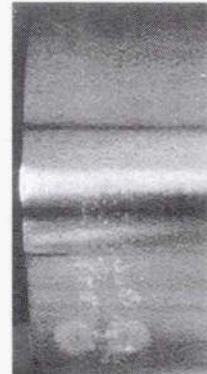

(a) Photograph of cavitation bubble.

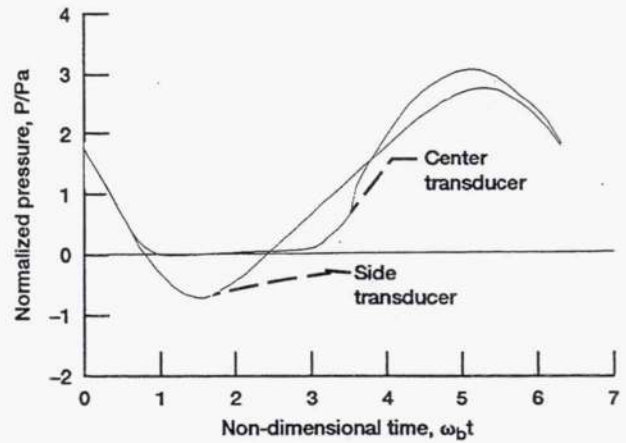

(b) Pressure variation.

Figure 11.—Cavitation bubble and simultaneously measured pressure, (transducers at $\theta = 315$ deg, $\omega_b = 251.3$ rad/s).

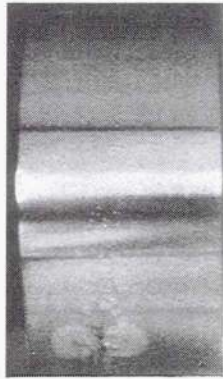

(a) Photograph of cavitation bubble.

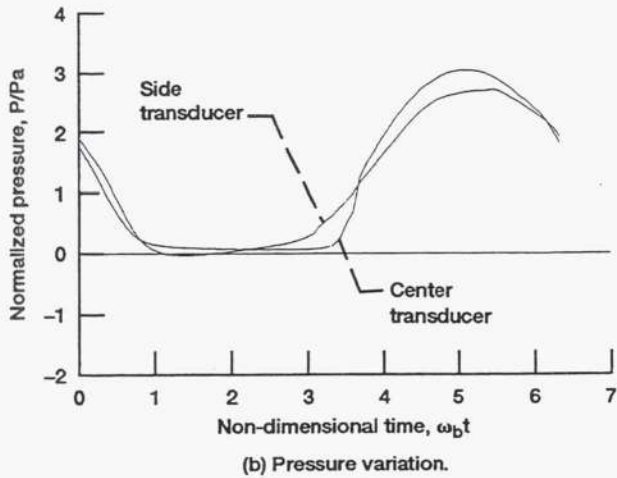

Figure 12.—Cavitation bubble and simultaneously measured pressure, (transducers at $\theta = 315$ deg, $\omega_b = 251.3$ rad/s).

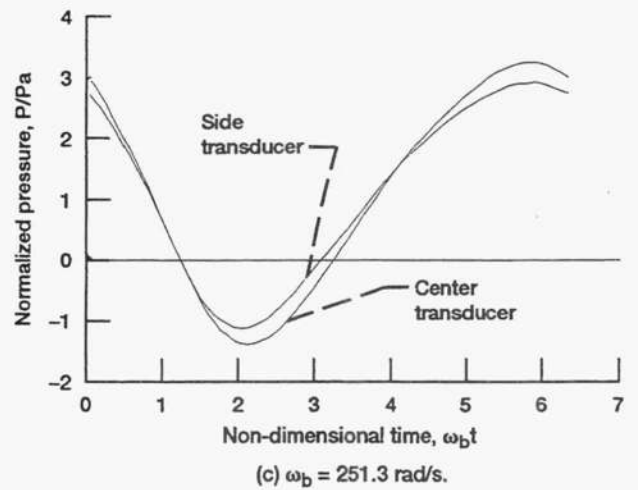
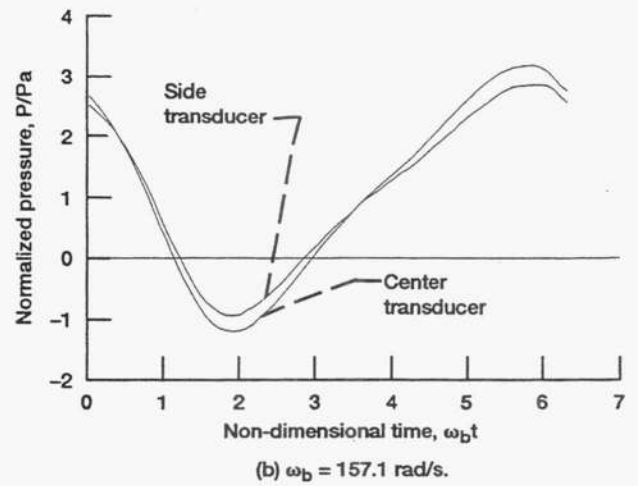
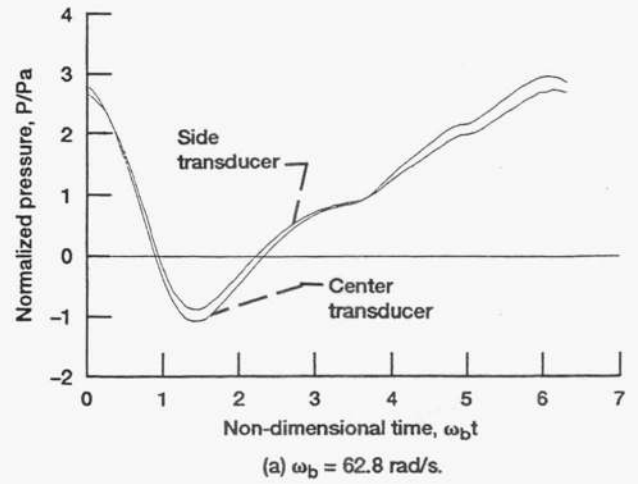

Figure 13.—Pressure variations at $\theta = 337.5$ deg.

REPORT DOCUMENTATION PAGE

Form Approved
OMB No. 0704-0188

Public reporting burden for this collection of information is estimated to average 1 hour per response, including the time for reviewing instructions, searching existing data sources, gathering and maintaining the data needed, and completing and reviewing the collection of information. Send comments regarding this burden estimate or any other aspect of this collection of information, including suggestions for reducing this burden, to Washington Headquarters Services, Directorate for Information Operations and Reports, 1215 Jefferson Davis Highway, Suite 1204, Arlington, VA 22202-4302, and to the Office of Management and Budget, Paperwork Reduction Project (0704-0188), Washington, DC 20503.

1. AGENCY USE ONLY (<i>Leave blank</i>)	2. REPORT DATE February 1994	3. REPORT TYPE AND DATES COVERED Technical Memorandum	
4. TITLE AND SUBTITLE Simultaneous Pressure Measurement and High-Speed Photography Study of Cavitation in a Dynamically Loaded Journal Bearing		5. FUNDING NUMBERS WU-505-63-5A IL161102AH45	
6. AUTHOR(S) D.C. Sun, David E. Brewe and Philip B. Abel		8. PERFORMING ORGANIZATION REPORT NUMBER E-6834	
7. PERFORMING ORGANIZATION NAME(S) AND ADDRESS(ES) NASA Lewis Research Center Cleveland, Ohio 44135-3191 and Vehicle Propulsion Directorate U.S. Army Research Laboratory Cleveland, Ohio 44135-3191		10. SPONSORING/MONITORING AGENCY REPORT NUMBER NASA TM-106456 ARL-TR-10	
9. SPONSORING/MONITORING AGENCY NAME(S) AND ADDRESS(ES) National Aeronautics and Space Administration Washington, D.C. 20546-0001 and U.S. Army Research Laboratory Adelphi, Maryland 20783-1145		11. SUPPLEMENTARY NOTES Prepared for the ASME/STLE Tribology Conference cosponsored by the American Society of Mechanical Engineers and the Society of Tribologists and Lubrication Engineers, San Diego, California, October 18-21, 1992. D.C. Sun, State University of New York at Binghamton, Department of Mechanical and Industrial Engineering, Binghamton, New York 13902-6000; David E. Brewe, Vehicle Propulsion Directorate, U.S. Army Research Laboratory; Philip B. Abel, NASA Lewis Research Center, Cleveland, Ohio 44135-3191. Responsible person, David E. Brewe, (216) 433-6067.	
12a. DISTRIBUTION/AVAILABILITY STATEMENT Unclassified - Unlimited Subject Category 37		12b. DISTRIBUTION CODE	
13. ABSTRACT (<i>Maximum 200 words</i>) Cavitation of the oil film in a dynamically loaded journal bearing was studied using high-speed photography and pressure measurement simultaneously. Comparison of the visual and pressure data provided considerable insight into the occurrence and nonoccurrence of cavitation. It was found that (1) for the submerged journal bearing, cavitation typically occurred in the form of one bubble with the pressure in the cavitation bubble close to the absolute zero; and (2) for cavitation-producing operating conditions, cavitation did not always occur; with the oil film then supporting a tensile stress.			
14. SUBJECT TERMS Cavitation pressure; Tensile stress; High speed photography; Pressure measurement; Liquid-vapor interfaces; Journal bearings; Fluid films			15. NUMBER OF PAGES 17
			16. PRICE CODE A03
17. SECURITY CLASSIFICATION OF REPORT Unclassified	18. SECURITY CLASSIFICATION OF THIS PAGE Unclassified	19. SECURITY CLASSIFICATION OF ABSTRACT Unclassified	20. LIMITATION OF ABSTRACT

National Aeronautics and
Space Administration
Lewis Research Center
21000 Brookpark Rd.
Cleveland, OH 44135-3191

Official Business
Penalty for Private Use \$300

POSTMASTER: If Undeliverable — Do Not Return