

Sinusoidal and Space Vector Pulse Width Modulation for Inverter

K. Mounika^{#1}, B. Kiran Babu^{^2}

[#]Final Year B. Tech, Dept. of EEE, KL University, Vaddeswaram, AP, India

[^]Assistant professor, Dept. of EEE, KL University, Vaddeswaram, AP, India
Address

Abstract- Inverters inherently have the property of controlling output frequency but the output voltage can't be varied. Usually to vary output voltage we have to vary supply voltage which is not always possible for this reason PWM techniques gained momentum. Basic aim of PWM technique is to control output voltage and harmonic reduction. Pulse-width modulation (PWM), or pulse-duration modulation (PDM), is a commonly used technique for controlling power to inertial electrical devices, made practical by modern electronic power switches. Here we apply PWM techniques like Sinusoidal pulse width modulation (SPWM) and Space Vector Pulse width Modulation (SVPWM) to inverter and study its performance.

In Sinusoidal Pulse width modulation (SPWM) we generate the gating signals by comparing a sinusoidal reference signal with a triangular carrier wave. In Space vector Modulation (SVPWM) we consider a rotating phasor which is obtained by adding all the three voltages. Modulation is accomplished by switching state of an inverter. Thus by comparing these two techniques we study the performance of our inverter.

Keywords - PWM (pulse width modulation), SPWM (sinusoidal pulse width modulation) and SVPWM (space vector pulse width modulation).

I. INTRODUCTION

Inverter is usually a device which converts DC power into AC power. In many industrial applications, it is often required to vary output voltage of inverter [1] due to the following reasons: 1.To compensate for the variations in input voltage.2.To compensate for the regulation of inverters.3. To supply some special loads which need variation of voltage with frequency. The various methods for the control of output voltage are: 1. External control of ac output voltage.

2. External control of dc input voltage.
3. Internal control of inverter.

In external type of control, circuit becomes bulky, costly and complicated so we go for internal control of inverter. In internal control inverter output voltage can be adjusted by exercising the control within the inverter itself. The two possible ways of doing this are: 1. Series inverter control. [7]
2. Pulse Width Modulation control. Pulse-width modulation (PWM) [2] uses a rectangular pulse wave whose pulse width is modulated resulting in the variation of the average value of the waveform. The simplest way to generate a PWM signal is the interceptive method, which requires only a saw tooth or a triangle waveform (easily generated using a simple oscillator) and a control wave. When the value of the reference signal is more than the modulation waveform, the PWM signal is in the high state, otherwise it is in the low state. The inverter output voltage is determined in the following:

- When $V_{control} > V_{tri}$, $V_{A0} = V_{dc}/2$
- When $V_{control} < V_{tri}$, $V_{A0} = -V_{dc}/2$

II. SINUSOIDAL PULSE WIDTH MODULATION

In single-pulse and multiple pulse modulation techniques the width of all pulses are same but in sinusoidal pulse width modulation the width of each pulse is varied in proportion to the amplitude of a sine wave. In this technique the gating signals are generated by comparing a sinusoidal reference signal with a triangular carrier wave. The DF and LOH [3] are reduced significantly. The output voltage is obtained from the mat lab results. The DF and LOH are measured by using FFT analysis. The gating signal for the

inverter is obtained by taking the repeating sequence(triangular wave)as the control signal and comparing it with the reference wave(sinusoidal wave).In order to detect or eliminate the zero sequence currents we use zero hold circuit and by comparing the with the help of greater than or equal to blocks.

III.SIMULATION CIRCUIT FOR SINUSOIDAL PWM

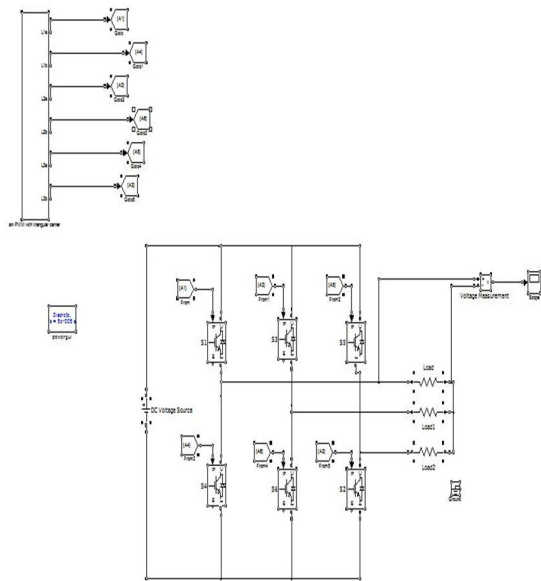

Fig:1 Circuit for sinusoidal pwm

IV. SPACE VECTOR PULSE WIDTH MODULATION

Space vector modulation is a PWM control algorithm [8] for multi-phase AC generation, in which the reference signal is sampled regularly; after each sample, non-zero active switching vectors adjacent to the reference vector and one or more of the zero switching vectors are selected for the appropriate fraction of the sampling period in order to synthesize the reference signal as the average of the used vectors. The topology of a three-leg voltage source inverter is Because of the constraint that the input lines must never be shorted and the output current must always be continuous a voltage source inverter can assume only eight distinct topologies. Six out of these eight topologies produce a nonzero output voltage and are known as non-zero switching states and the remaining two topologies produce zero output voltage and are known as zero switching states.

V. SIMULATION CIRCUIT FOR SVPWM

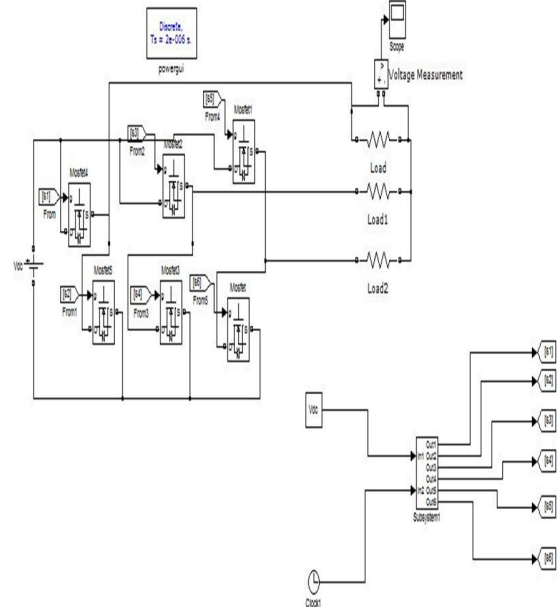

Fig:2 circuit for svpwm

VI. IMPLEMENTING SVPWM

The SVPWM [4] can be implemented by using wither sector selection algorithm or by using a carrier based space vector algorithm. The types of SVPWM implementations are: a) Sector selection based space vector modulation b) Reduced switching Space vector modulation c) Carrier based space vector modulation d) Reduced switching carrier based space vector modulation.

VII. STEPS TO IMPLEMENT SVPWM, THE CONVENTIONAL METHOD

1) The sector in which the tip of the reference sector is situated is to be determined from the instantaneous phase references V_a^* , V_b^* and V_c^*

- $V_a^*, V_b^*, V_c^* \rightarrow v_{\alpha}, v_{\beta} \rightarrow \theta = \text{Tan}^{-1}(v_{\beta} / v_{\alpha})$
- $\alpha = \theta - k(60^{\circ})$; k such that $\alpha < 60^{\circ}$
- Sector number = k + 1

2) Computation of T_1 and T_2 ; here lookup tables are needed to know the values of $\text{Sin}(60^{\circ} - \alpha)$ and $\text{Sin} \alpha$
 3) Determination of switching vectors.
 4) Assert the appropriate control signals to affect the required switching action.
 From this analysis, the space vector modulation task can be solved into following steps to make actual PWM pattern.

Step-1: Sector identification

By comparing the stationary frame d-q components of the reference voltage vector, the sector where the reference voltage vector is located is identified.

Step-2: Calculating the effective times

Using the d-q components of the reference voltage vector, a sine loop voltage and a dc-link voltage information, the effective times T1, T2 are calculated. Instead of the sine table, to reduce the calculation time, another look-up table which contains the corresponding to each sector number may be used.

Step-3: Determining the switching states

Using the corresponding sector information the actual switching time for each inverter leg is generated from the combination of effective times and zero sequence time. Equating volt-seconds along the α -axis:

$$(|V_{sr}| \cos \alpha) * T_s = V_{dc} * T_1 + (V_{dc} \cos 60^\circ) * T_2$$

Equating volt-seconds along the β -axis:

$$(|V_{sr}| \sin \alpha) * T_s = (V_{dc} \sin 60^\circ) * T_2$$

Solving the above two simultaneous equations, one gets:

$$T_1 = \frac{|V_{sr}| T_s \sin(\pi/3 - \alpha)}{V_{dc} \sin(\pi/3)}$$

$$T_2 = \frac{|V_{sr}| T_s \sin \alpha}{V_{dc} \sin(\pi/3)}$$

$|V_{sr}|$ represents the length of the reference Vector and α is measured from the start of the vector.

$$T_1 = \frac{2T_s[v_\alpha \sin(\pi/3) - v_\beta \cos(\pi/3)]}{\sqrt{3}V_{dc}} ; T_2 = \frac{2T_s v_\beta}{\sqrt{3}V_{dc}}$$

Substituting

$$v_\alpha = \frac{3}{2} v_a^*$$

$$v_\beta = \frac{\sqrt{3}}{2} (v_b^* - v_c^*)$$

$$T_1 = \frac{T_s (v_a^* - v_b^*)}{V_{dc}} ; T_2 = \frac{T_s (v_b^* - v_c^*)}{V_{dc}}$$

The imaginary switching periods T_{as} , T_{bs} and T_{cs} are defined as:

$$T_{as} \equiv \left(\frac{T_s}{V_{dc}}\right) v_a^* ; T_{bs} \equiv \left(\frac{T_s}{V_{dc}}\right) v_b^* ; T_{cs} \equiv \left(\frac{T_s}{V_{dc}}\right) v_c^*$$

The active vector switching times T_1 and T_2 in sector-1 may be expressed as:

$$T_1 = T_{as} - T_{bs} ; T_2 = T_{bs} - T_{cs}$$

Extending this procedure, for the other sectors, the active vector switching times (T_1 and T_2) [4] and for the respective sectors may be expressed in terms of the imaginary switching times (T_{as} , T_{bs} and T_{cs}) for a particular sampling interval. The effective time T_{eff} is the time during which the active vectors are switched in a sector and is given by ($T_1 + T_2$). This may be determined as the difference between the maximum and minimum values among T_{as} , T_{bs} and T_{cs} . Hence, $T_0 = T_s - T_{eff}$.

$$T_{eff} = \max\{T_{as}, T_{bs}, T_{cs}\} - \min\{T_{as}, T_{bs}, T_{cs}\} = T_{max} - T_{min}$$

The offset time, T_{offset} required to distribute the zero voltage symmetrically during one sampling period is given by:

$$T_{offset} = \frac{T_0}{2} - T_{min}$$

The actual switching times for each the inverter leg can be obtained by the time shifting operation as follows:

$$T_{ga} = T_{as} + T_{offset} ; T_{gb} = T_{bs} + T_{offset} ; T_{gc} = T_{cs} + T_{offset}$$

VIII. DC-BUS UTILIZATION WITH SVPWM

The principal advantage of the SVPWM over SPWM is that it enhances the DC bus utilization [6] by about 15%. It is instructive to evaluate the sample-averaged pole voltage of a phase, V_{AO} for instance, to understand this fact.

During ($0 < \omega t < 30$)

$$V_{AO,avg} = \frac{V_{dc}/2}{T_s} \left(-\frac{T_0}{2} - T_1 + T_2 + \frac{T_0}{2} \right)$$

$$V_{BO,avg} = \frac{V_{dc}/2}{T_s} \left(-\frac{T_0}{2} - T_1 - T_2 + \frac{T_0}{2} \right)$$

$$V_{CO,avg} = \frac{V_{dc}/2}{T_s} \left(-\frac{T_0}{2} + T_1 + T_2 + \frac{T_0}{2} \right)$$

During (30<Wt<90)

$$V_{AO,avg} = \frac{V_{dc}/2}{T_s} \left(-\frac{T_0}{2} + T_1 + T_2 + \frac{T_0}{2} \right)$$

$$V_{BO,avg} = \frac{V_{dc}/2}{T_s} \left(-\frac{T_0}{2} - T_1 - T_2 + \frac{T_0}{2} \right)$$

$$V_{CO,avg} = \frac{V_{dc}/2}{T_s} \left(-\frac{T_0}{2} + T_1 - T_2 + \frac{T_0}{2} \right)$$

$$V_{AO,avg} = \frac{V_{dc}/2}{T_s} * \frac{|V_{sr}|}{V_{dc}} * \frac{T_s}{\sin 60} (-\sin(\theta - \alpha) + \sin \alpha)$$

$$\omega t = \alpha - 30^0$$

when $\omega t \leq 30^0$ simplifying

Noting that

$$\omega t = \alpha + 30^0$$

when $30^0 \leq \omega t \leq 90^0$

simplifying

$$V_{AO,avg} = \frac{|V_{sr}|}{\sqrt{3}} \sin(\omega t + 30^0)$$

The peak value of the A-phase voltage, while the inverter is operated in the range of linear modulation is given by:

$$V_{ph,peak} = (2/3) * |V_{sr}|$$

The maximum magnitude of the reference voltage space vector corresponds to the radius of the biggest circle that can be inscribed in the hexagon. Thus, the maximum value of the peak-phase voltage is given by

$$V_{ph,peakmax} = \frac{2}{3} * \frac{\sqrt{3}}{2} * V_{dc} = \frac{V_{dc}}{\sqrt{3}} = 0.577 * V_{dc}$$

IX. OUTPUT VOLTAGE FOR SPWM INVERTER

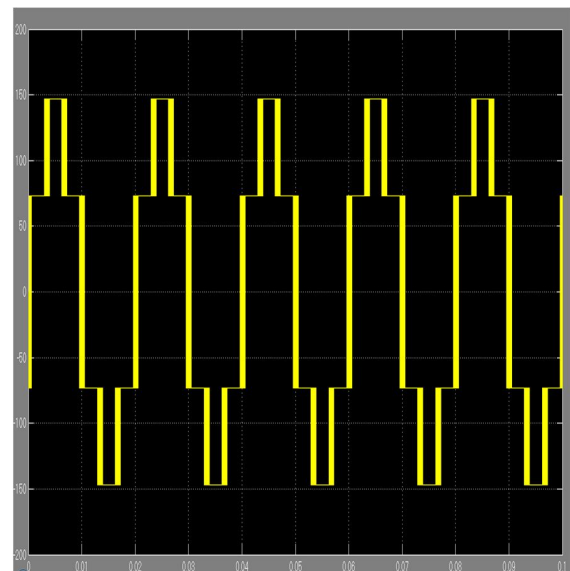

Fig:3 output waveform of spwm

Fig:5 fft analysis of spwm

X. OUTPUT VOLTAGE OF SVPWM

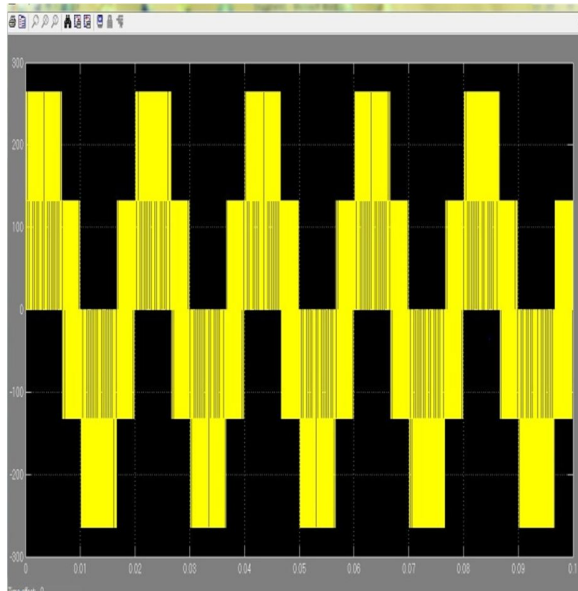
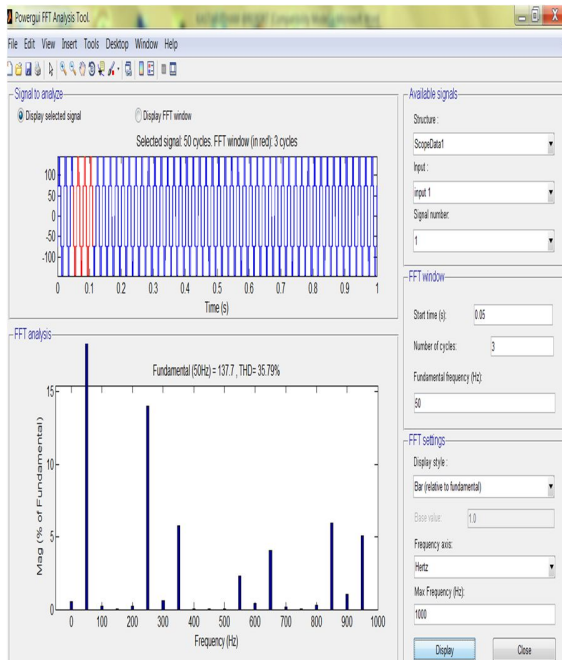

Fig:4 output waveform of svpwm

Simulation results [5] are observed by the following analysis.

XI. FFT ANALYSIS OF SPWM



XII. FFT ANALYSIS FOR SVPWM

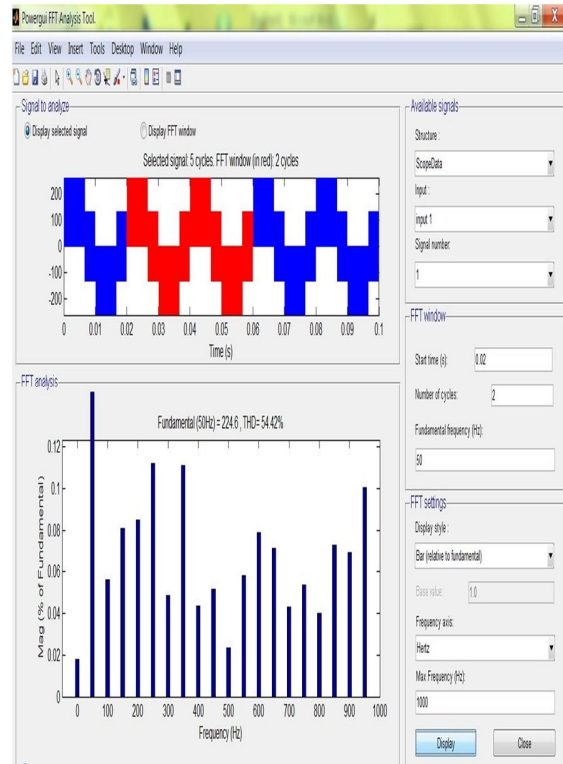

Fig:6 fft analysis of svpwm

XIII. CONCLUSION

Compared to SPWM the Total harmonic distortion (THD) and lower order harmonics (LOH) contents are decreased in SVPWM. It is known that the maximum value of the peak-phase voltage that can be obtained from a 3-Ph inverter with Sinusoidal Pulse Width Modulation (SPWM) technique is equal to $V_{dc}/2$. It is therefore evident that SVPWM achieves a better DC bus utilization compared to SPWM (by about 15.4%).

XIV. LATEST IMPROVEMENTS

- Microprocessor-based controllers eliminate analog, potentiometer-based adjustments.
- Digital control capability.
- Built-in Power Factor correction.
- Radio Frequency Interference (RFI) filters.
- Short Circuit Protection (automatic shutdown).
- Advanced circuitry to detect motor rotor position by sampling power at terminals, ASD and motor circuitry combined to keep power waveforms sinusoidal, minimizing power losses.
- Motor Control Centers (MCC) coupled with the ASD using real-time monitors to trace motor-drive system performance.
- Higher starting torques at low speeds (up to 150% running torque) up to 500 HP, in voltage source drives.
- Load-commutated Inverters coupled with synchronous motors.

REFERENCES

- [1]. Dr. P.S.Bimbhra "power electronics, Fourth edition, 2009
- [2]. Muhammad H. Rashid, "Power electronic circuits, devices, and applications. Low price edition. Isbn:978-81-317-0246-8.
- [3]M.D.Singh, K.B.Kanchandani "Power electronics" Tata McGraw-Hill Education Private limited, Isbn: 13:978-0-07-058394.
- [4]. Mohan, Undeland, Riobbins, "Power electronic converters, applications and design" WILEY STUDENT EDITION, Isbn: 978-8126-510900.
- [5].www.mathwork.com
- [6]. B.K. Bose. 1986. Power electronics and ac drives. Prentice hall Inc., Englewood Cliffs, New Jersey.
- [7]. Shoji Fukuda and Yoshitaka Iwaji, "Introduction of the Harmonic Distortion Determining Factor and its Application to Evaluating Real Time PWM Inverters," IEEE transactions on Industry Applications, Vol. 31, No. 1, January/February, 1995.
- [8]. G. Narayanan, Harish K. Krishnamurthy, Rajapandian Ayyanar and V. T. Ranganathan, "Space Vector Based Hybrid PWM Techniques for Reduced Current Ripple," IEEE Transactions on Industrial Electronics, Vol. 55, No. 4, April 2008.

BIOGRAPHIES



Kondapalli Mounika was born in India in 1991. She is pursuing B. Tech final year in KL University in Electrical and Electronics Engineering. Her field of interest is in FACTS devices and Power Electronics.

Email Id: mouni.kondapalli99@gmail.com



B. Kiran babu received the B. Tech degree from JNTU Hyderabad in the year 2004, the M. Tech degree in power system engineering from MNIT Jaipur, Rajasthan in the year 2007. His research area includes distribution system reconfiguration, transmission loss allocation.

Email Id: kiranbabu.b@gmail.com