

2007-01-01

## Slow and Fast-light in Optical Fibers: an Overview

Ronny Henker

*Deutsche Telekom Fachhochschule Leipzig*

Thomas Schneider

*Deutsche Telekom Fachhochschule Leipzig*

Kai-Uwe Lauterbach

*Deutsche Telekom Fachhochschule Leipzig*

*See next page for additional authors*

Follow this and additional works at: <https://arrow.tudublin.ie/engschececon>



Part of the [Electrical and Computer Engineering Commons](#)

---

### Recommended Citation

Henker, R. et al. (2007) Slow and fast-light in optical fibers: an overview. *International Students and Young Scientists Workshop in Photonics and Microsystems*, pp.32-37. Dresden, 8-10 July, 2007, doi:10.1109/STYSW.2007.4559119

This Conference Paper is brought to you for free and open access by the School of Electrical and Electronic Engineering at ARROW@TU Dublin. It has been accepted for inclusion in Conference papers by an authorized administrator of ARROW@TU Dublin. For more information, please contact [arrow.admin@tudublin.ie](mailto:arrow.admin@tudublin.ie), [aisling.coyne@tudublin.ie](mailto:aisling.coyne@tudublin.ie).



This work is licensed under a [Creative Commons Attribution-NonCommercial-Share Alike 4.0 License](#)

---

**Authors**

Ronny Henker, Thomas Schneider, Kai-Uwe Lauterbach, Markus Junker, Max Ammann, and Andreas Schwarzbacher

# Slow and Fast-Light in Optical Fibers – An Overview

Ronny Henker<sup>1,2)</sup>, Thomas Schneider<sup>1)</sup>, Kai-Uwe Lauterbach<sup>1,2)</sup>, Markus Junker<sup>1,2)</sup>, Max James Ammann<sup>2)</sup>, and Andreas Thomas Schwarzbacher<sup>2)</sup>

<sup>1)</sup>Deutsche Telekom AG, Hochschule für Telekommunikation, Leipzig (FH), Germany

<sup>2)</sup>School of Electronic & Communications Engineering, Dublin Institute of Technology, Dublin, Ireland  
ronny.henker@hft-leipzig.de

**Abstract** - Slow- and Fast-Light is the control of the velocity of light in a medium by light. As a fascinating new field in physics there is a fundamental interest on this effect on the one side, but on the other side there exist a lot of practical applications for telecommunication and information systems. Among these are optical signal processing, the radio frequency-photonics, nonlinear optics and spectroscopy in time domain. Furthermore, the Slow- and Fast-Light effect can be seen as a key technology for optical delay lines, buffers, equalizers and synchronizers in packed switched networks. To realize the effect there are different methods and material systems possible. Beside these especially the nonlinear effect of stimulated Brillouin scattering (SBS) is of special interest because it has several advantages. This article gives an overview about the fundamentals and limits of the Slow- and Fast-Light effect in general and based on the SBS in optical fibers. Some experimental results which were achieved so far are shown.

## I. INTRODUCTION

Today's data networks consist of optical fibers for the transport of data signals and network nodes for their switching through the net. The data traffic is nearly doubled in transport networks every year. But, this is not a big problem for optical transmission technologies because every fiber is able to transmit more than 100 channels with data rates of 10 or 40 Gbit/s. Contrary to this the capacity of network nodes is doubled only every 18 months [1].

Inside every node the optical pulses are converted into electrical signals to process and to switch them. After that they are converted back into the optical domain to transmit them to the next node over the fiber. For the processing of the signal in the node it is necessary to store the pulses for a certain time otherwise it would lead to collisions. Therefore, every signal channel needs an own card for the handling which is shown in Fig. 1.

If the data traffic increases in the networks the number of channels and so the number of handling cards increases as well. Then, one problem is that the physical dimensions of the nodes expand. Hence, the distance between the in- and the output of the card increases drastically. Electrical signals with a high frequency cannot pass long distances without suffering significant losses and distortions. But for optical signals this is not a problem. That is why there has begun a reinforced development of optical alternatives to electrical network

nodes. Then, these optical nodes should take over all functions of the electrical ones including signal buffering.

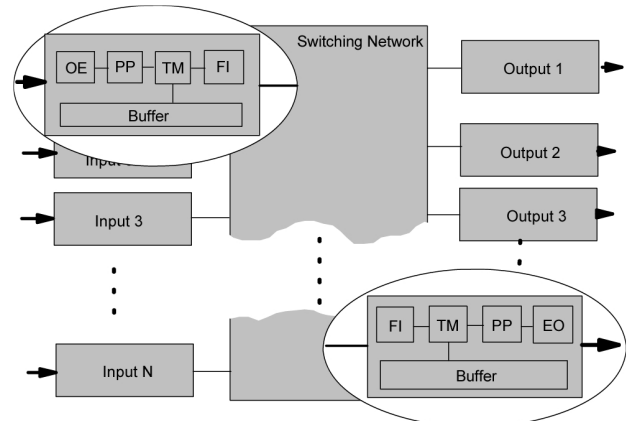

Fig. 1 Schematic setup of a network node. OE; optical-electrical conversion, PP; packet processor, TM; traffic manager, FI; fabric interface, EO; electrical-optical conversion.

## II. OPTICAL BUFFERS

Most functions of an optical network node have already been shown in Ref. [2], [3]. But the intermediate storage of the signals is not a satisfactorily solved problem up to now. For an ideal processing the packets have to be buffered on the in- and outputs of the network channel cards. This basic requirement is shown in Fig. 2.

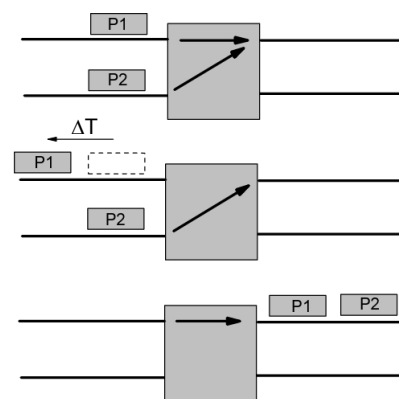

Fig. 2 Principle of an optical buffer for an avoiding of collisions.

In the upper picture there are two packets ( $P1$  and  $P2$ ) which want to access on one output port at the same time. Without an optical buffer this would lead to a collision and a blockade of the node. Hence, one of the packets ( $P1$ ) is

delayed by  $\Delta T$  like shown in the middle picture. So, the node has enough time to process  $P2$  at first and then  $P1$  as can be seen in the lower picture.

Such an optical buffer can be defined as follows [4]:

- The data stream is completely optically. No optical-electrical-optical conversion is proceeded.
- The buffer stores the signal for a time  $\Delta T$  only with low distortions and attenuations.
- The delay time is variable and externally controllable.

The requirements on the storage capacity and the reaction rate depend on the respective application.

The basic form of an optical buffer is shown in Fig. 3. In the upper picture (Fig. 3a) a packet is sent to a delay line with a fixed length  $L$ , e. g. an optical fiber. Inside the fiber segment the signal moves with the group velocity:

$$v_g = \frac{\partial \omega}{\partial k} = \frac{c - \omega \frac{\partial n(k, \omega)}{\partial k}}{n(k, \omega) + \omega \frac{\partial n(k, \omega)}{\partial \omega}} \quad (1)$$

where  $n$  is the real part of the refractive index of the fiber and  $k$  is the wave number of the optical waveguide. Then, the time delay is caused by the fiber length and amounts  $T_g = L/v_g$ . With  $a$  as the number of passes through the delay line the time delay becomes  $a \times T_g$ . Hence, the storage capacity and the number of bits, respectively, depend on  $T_g$ . But, if the number of bits is longer there occur interferences between the bits at the beginning and the end of the packet. And, if the packet is coupled into the fiber once it can be read out only after a whole circulation. Next to the fiber length the waveguide dispersion  $\partial n/\partial k$  can influence the time delay.

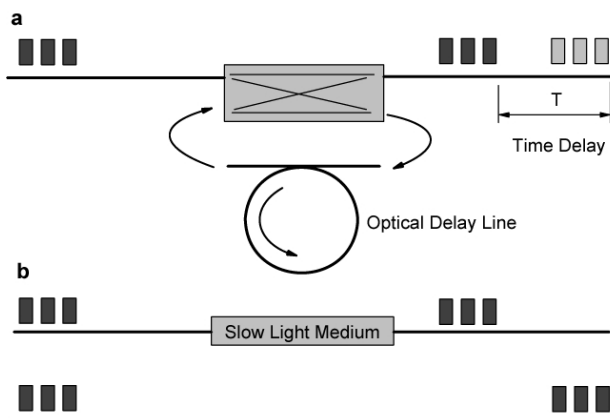

Fig. 3 Basic concept of optical storage; a) via delay line; b) via medium with increased group index.

Huge group delays can be achieved for example by optical waveguides which are wound up to a coil [5]. With resonators in ring structures which are built up by “Silicon-on-Insulator” (SOI) -structures it is possible to get extremely small optical

buffers with dimensions of only  $0.09 \text{ mm}^2$ . This Silicon-chip is able to store 10 bit at data rates up to 5 Gbit/s error-free [6].

The main problem of these methods is that the storage time is fixed and cannot be varied. But, in data networks the arrival time is stochastic and not quantized. The attenuation of the signal in long passive delay lines is another problem.

Due to these disadvantages the so-called “Slow-Light” concept which could provide a way out of these problems has been discussed and developed for the last few years.

### III. SLOW- AND FAST-LIGHT

Due to the Slow- and Fast-Light effect the time delay does not depend on the length of a fiber but on the value of the group index  $n_g$  like shown in Fig. 3b. If the wave guide dispersion can be neglected (1) changes to:

$$v_g = \frac{c}{n(\omega) + \omega \frac{\partial n(\omega)}{\partial \omega}} = \frac{c}{n_g} \quad (2)$$

If  $n_g$  is arbitrarily alterable then any time delay can be adjusted. Equation (2) shows that a change of the frequency sensitivity of the group index  $\omega \partial n/\partial \omega$  results in a change of the group velocity. A strong material dispersion causes automatically a big change of the group delay. If it is positive the pulse is delayed and if it is negative the pulse is accelerated sometimes even to vacuum superluminal velocity.

Mostly such a dispersion occurs if the frequency of the light is nearby material resonances which results in absorption or amplification processes. The first experiments of the delay of light have been shown in thinned [7] and by the effect of “electromagnetically induced transparency” (EIT) [8] in ultra hot [9] and cold atom-gases [10]. But, the problem of such systems is that they have a narrow bandwidth and that the used wavelengths are not in the range of the applications in telecommunications. Furthermore, it is difficult to integrate cold and hot gases into optical networks.

This is the reason for a development of many other techniques which works at room temperatures and which can be easily integrated into existing communication systems. In this case the natural resonance of the material was not used anymore. Now, the resonances were created artificially in semiconductor-nanostructures [4], quantum-well [11] and quantum-dot [12] systems as well as in waveguides which work like photonic crystals [13]. The time delay nearby a resonance created by amplification was shown in Erbium-doped fiber amplifiers (EDFA) [14] and semiconductor optical amplifiers (SOA) [15]. The problem with such amplifiers is that the time delay is combined with a gain of the signal on the one hand but also an amplified spontaneous emission on the other hand. Finally, all these described methods have the disadvantage that the time delay is very low and the storage capacity does not exceed 1 bit.

## IV. BRILLOUIN SCATTERING

In optical fibers also nonlinear effects offer the opportunity to change the group velocity. This has the big advantage that the fibers can be integrated seamlessly in optical networks. For generating Slow-Light one can use e. g. four wave mixing (FWM) together with the fiber dispersion [16] and Raman scattering [17]. But the effect of SBS is of very special interest [18] because there are several advantages:

- The SBS needs just small pump powers for high time delays.
- For SBS off-the-shelf telecommunication equipment can be used.
- The SBS works in all fiber types in their transparency range.

With SBS group velocities between 71000 km/s and vacuum superluminal velocity have been shown [19]. The principle of SBS can be seen in Fig. 4.

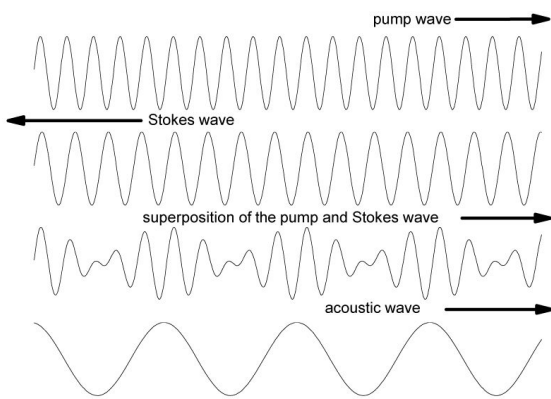

Fig. 4 Principle of the stimulated Brillouin scattering [20].

A strong pump wave propagates through the waveguide. A part of the optical power is scattered on fluctuations of the density in the opposite direction. This so-called Stokes-wave superimposes with the pump wave and creates a density wave in direction of the pump wave via electrostriction. Hence, more optical power is scattered on this density wave which in turn amplifies the density wave again and so on. So, from a certain power of the pump wave (threshold) the process becomes stimulated.

Thereby the pump and the density waves have a relative speed to each other, and hence the Stokes wave has another frequency and wavelength, respectively, as the pump wave  $f_p$ . This frequency shift is the so-called “Brillouin shift”  $f_B$  which is around 11 GHz in a standard single mode fiber (SSMF) at a pump wavelength of 1550 nm.

If the input power is under the threshold the pump wave creates a gain inside the fiber on which a contra propagating signal can be amplified. Therefore, the signal and the pump wave have to have a frequency shift equal to the Brillouin shift  $f_p - f_B$ . If another wave is contra propagating with a frequency of  $f_p + f_B$  it acts like a pump wave and transfers its power to the actual pump wave; it is attenuated. The result is a gain and a loss as can be seen in the upper picture of Fig. 5. These Brillouin gain and loss have a relatively small full

width at half maximum (FWHM) bandwidth  $\Delta f_B$  of around 30 MHz and they are accompanied with a change of phase – which corresponds to a dispersion – and hence a change of the refractive index in the fiber, like the middle and lower part of Fig. 5 shows.

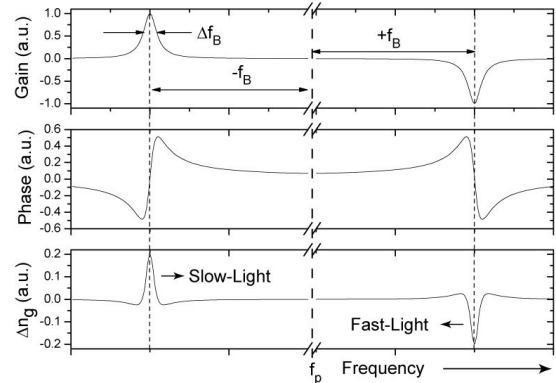

Fig. 5 Gain and loss (top), phase (middle) and group index change (bottom) via Brillouin scattering.

## V. SLOW- AND FAST-LIGHT BASED ON SBS

According to (2) the gradient of the refractive index leads to a change of the group velocity. As can be seen in Fig. 5 for a Brillouin gain this gradient is positive and hence the group index increases. The group velocity is reduced and so the pulses are delayed (Slow-Light). For a Brillouin loss spectrum a negative gradient is resulted and the group index becomes smaller which leads to a higher group velocity (Fast-Light).

If a pulse is propagating through the medium the amplitude of the output pulse  $A(\omega, z)$  relating to the input pulse  $A(\omega, 0)$  is:

$$A(\omega, z) = A(\omega, 0) e^{jk(\omega)z} \quad (3)$$

with  $z$  as the length of the medium and  $k(\omega)$  as the complex wave number. A medium is not ideal in reality, hence the complex wave number can be developed into a Taylor-series:

$$k(\omega) = k_0 + k_1(\omega - \omega_0) + \frac{1}{2}k_2(\omega - \omega_0)^2 + \dots \quad (4)$$

with  $k_1 = dk/d\omega$  and  $k_2 = dk^2/d\omega^2$  as the reciprocal group velocity and as the group velocity dispersion [20]. So, the time delay due to the propagation through the fiber is  $\Delta T = z(k_1 - 1/c)$ . For a SBS gain the complex wave number in the fiber becomes:

$$k(\omega) = n_0 \frac{\omega}{c} + \frac{g_0}{z} \left( \frac{\gamma}{(\omega - \omega_0) + j\gamma} \right) \quad (5)$$

with  $n_0$  as the complex refractive index in the fiber,  $\gamma = \pi \Delta f_B$  as the half FWHM-bandwidth of the SBS as angular frequency and

$$g_0 = \frac{g P L_{eff}}{A_{eff}} \quad (6)$$

as the gain in the line center at  $\omega = \omega_0$ . In (6)  $g$  is the Brillouin gain,  $P$  is the optical input power,  $L_{eff}$  is the effective fiber length and  $A_{eff}$  the effective fiber profile [20].

The imaginary part of (5) leads to an amplification of the pulses (Fig. 5, top) and the real part to a phase change (Fig. 5, middle). According to (4) the derivation of the real part leads to a group index change (Fig. 5, bottom). Then, the time delay in the line center of the gain only caused by the SBS is:

$$\Delta T_{SBS} = \frac{1}{c} (L_{eff} n_{SBS} - L n_{gn}) = \frac{g_0}{\gamma} \quad (7)$$

with  $n_{gn}$  as group index without SBS and  $n_{SBS}$  as the group index only caused by the SBS.

Simultaneously the pulse is distorted by higher orders of (4). The factor of the pulse broadening  $B$  is the relation between the output-  $\tau_{out}$  and input pulse width  $\tau_{in}$ . It can be described by [21]:

$$B = \frac{\tau_{out}}{\tau_{in}} = \sqrt{1 + \frac{16 \ln 2}{\tau_{in}^2 \gamma^2} g_0} \quad (8)$$

Thus, every time delay accompanies with a broadening of the pulse. But, with a broader bandwidth of the SBS the pulse broadening declines.

A possible experimental setup for the generation of Slow- and Fast-Light shows Fig. 6. At first only the components drawn with a solid line are needed. The fiber laser on the right hand side creates the carrier wave for the pulses which are generated by a pulse generator combined with a Mach-Zehnder modulator. Normally, we use pulses with a width of 30 ns and a repetition rate in the MHz-range at wavelengths of 1550 nm. Then, these are coupled into a 50 km long SSMF which is our Slow- and Fast-Light medium. We use such a long fiber in order to minimize the pump powers. All other research groups use shorter fibers but they just need higher pump powers. Another way is to use short highly-nonlinear fibers [22], [23].

From the other side a pump wave (Pump1) from a DFB-laser diode with the frequency  $f_{p1}$  is coupled into the same fiber via an optical circulator. The gain spectrum which is induced by this pump wave can be seen in the inset b of Fig. 6. To control the time delay the power of the pump laser is varied by a tunable optical attenuator. Finally, the delayed pulses are detected by a photodiode on port 3 of the circulator and interpreted via an oscilloscope.

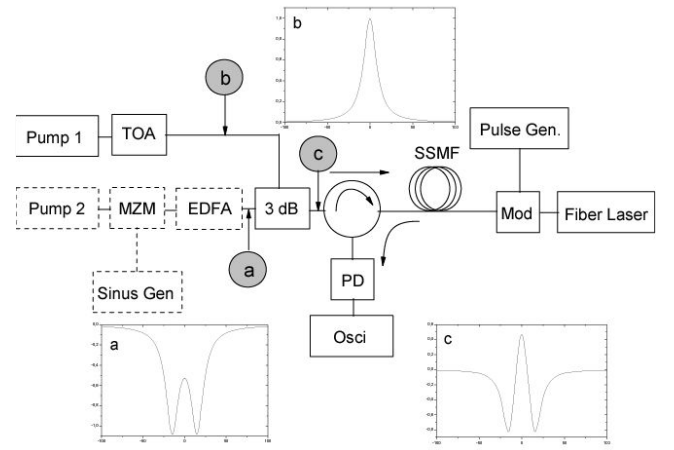

Fig. 6 Experimental setup. MZM; Mach-Zehnder modulator, TOA; tunable optical attenuator, Gen; generator, Mod; modulator, PD; photodiode, Osci; oscilloscope.

Figure 7 shows a typical result of pulse delays via SBS. As can be seen the delay increases with increasing pump powers, but the distortion (pulse broadening) is increased as well. Higher time delays are not possible with such a setup because the range of stimulated emission of the SBS is reached with higher pump powers. For our setup this occurs at powers higher than approximately 7 mW.

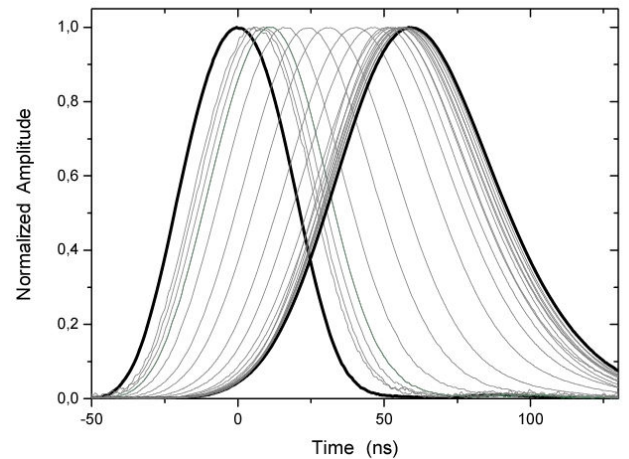

Fig. 7 Delay pulses via SBS.

## VI. LIMITS OF THE METHOD

One problem of the SBS is the narrow FWHM-bandwidth of only 30 MHz which can be used for a delay of pulses with a maximum data rate of 15 Mbit/s. On the one hand the natural Brillouin bandwidth  $\Delta f_B$  is defined by parameters of the used fiber. But on the other hand the resulting bandwidth  $\gamma$  is based on a convolution between the bandwidth of the pump signal  $\Delta f_P$  and  $\Delta f_B$  [20]:

$$\gamma = \pi (\Delta f_p \otimes \Delta f_B) \quad (9)$$

Thus, the bandwidth of the SBS can easily be broadened by an external or direct modulation of the pump wave. In [19] for

example the pump laser was modulated directly with a pseudo random bit sequence (PRBS) signal with a data rate of 38 Mbit/s. The result was a pump spectrum of 325 MHz. In [24] the Slow-Light bandwidth was broadened to 1.9 GHz by a direct modulation of the pump wave with a Gaussian noise. The same method was used in [25]. There the SBS bandwidth was enhanced to 12.6 GHz inside a highly-nonlinear fiber with a Brillouin shift of 9.6 GHz.

As can be seen in Fig. 5 an enhancement of the pump spectrum leads to a wider Brillouin gain spectrum but a wider loss spectrum as well. At the position of the pump wavelength the gain and the loss cancel each other out. Hence, it was assumed that the maximum bandwidth is in the range of  $2f_B$  [25], [26]. This means that data rates of not more than 10 Gbit/s could be delayed. But in optical telecommunication networks data rates of 40 Gbit/s and more should be processed. So, in [27] we were able to show how the Brillouin bandwidth can be further enhanced by using multiple pump sources. If a second pump laser is used (Pump2 in Fig. 6) at a frequency of  $f_{P2}=f_{P1}-2f_B$  its loss can be compensated by the gain of the first one. With a pump power of  $f_{P1}$  higher than  $f_{P2}$  the result is an overall gain which is further enhanced. By adding more pump sources in the same manner this method does not have a limit and we believe that every arbitrary bandwidth can be generated.

A second problem is the small storage capacity which is combined with the pulse width of the delayed pulses. As can be seen in Fig. 7 it is merely 1 bit.

In most of the publications the maximum time delay is around 30 ns by using SBS with the natural bandwidth. Thereby, the Brillouin threshold limits the delay. Hence, different methods to enhance the maximum time delay were developed. In [28] four delay lines with an own pump source were cascaded. Additionally the pulse was attenuated in every passage from one to another line. With this method time delays of 152 ns were achieved. But, due to the pulse broadening from 40 ns to 102 ns the effective time delay was only 1.5 bit. In [29] we have shown that these distortions can be decreased by broaden the pump spectrum with multiple Brillouin lines. A distortion reduction of around 30% was achieved.

The disadvantage of this method is that it is very complicated. A technique which is much easier and with which much higher time delays can be achieved is to superimpose the narrowband Brillouin gain with a broadened Brillouin loss. The delay depends on the gradient of the gain whereas the amplification and the saturation respectively is a function of the maximum height of the gain. With the superposition of the Brillouin spectrums the delay is decoupled from the amplification process and hence very high time delays can be achieved.

One result of this method is shown in Fig. 8. Input pulses with a width of 34 ns were delayed by 100 ns which corresponds a storage capacity of 3 bit. Without an additional loss spectrum the maximum time delay was limited to approximately 44 ns. As can be seen from the inset of Fig. 8 the gain as well as the output amplitude did not increase with

the time delay enhancement. The temporal width of the output pulse was 64 ns and so the storage capacity was around 1.6 bit [30].

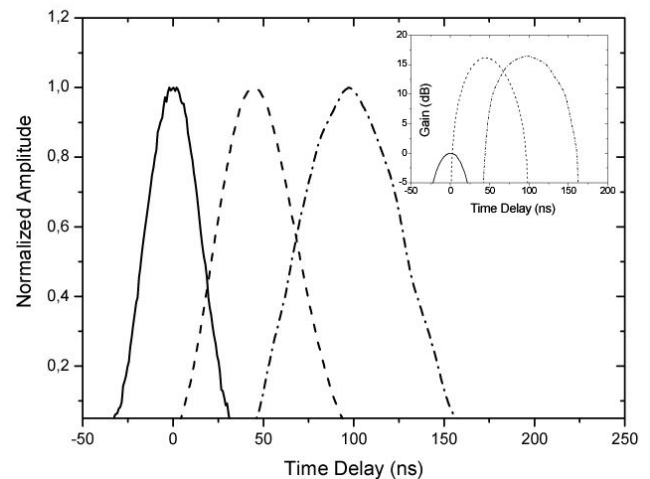

Fig. 8 Delayed pulses. solid line: reference, dashed line: without additional loss spectrum, dashed-dotted line: with additional loss spectrum.

With this method the line center height of the gain was shifted but the gradient of the spectrum was kept. If the gradient is changed in addition to the line center shift the maximum time delay can be further enhanced. For this we superimpose the gain spectrum (inset b of Fig. 6) with two loss spectrums (inset a of Fig. 6) which are positioned at the wings of the gain [31]. The resulting spectrum is shown in inset c of Fig. 6. These both loss spectrums are generated by an external modulation of the pump wave (Pump2) with a sinusoidal signal via MZM in double sideband suppressed carrier mode. Finally, we achieved a further enhancement of the maximum time delay up to 120 ns [32].

How much the storage capacity of these procedures is limited theoretically is not really known at this moment. In [33] it is supposed that the maximum time delay – for a maximum toleratable pulse broadening to the double – is:

$$\left( \frac{\Delta T_{SBS}}{\tau_{in}} \right)_{\max} = \frac{3}{2} \gamma \tau_{in} \quad (10)$$

By choosing  $\gamma$  as high as one wants the storage capacity can be reach any dimension. Another assumption is shown in [34] where the gain  $G$  for buffering  $N$  bits has to be:

$$G \approx 50N^{\frac{3}{2}} \quad (11)$$

For a storage capacity of more than 5 bits the gain should be higher than 560 dB which is not realistic. Even for our 3 bit delay we would need 260 dB. But, like one can see in Fig. 8 we used a gain of only 16 dB. Hence, in equation (11) there is disregarded the opportunity to decouple the time delay and the gain.

## VII. CONCLUSIONS

Next to the fundamental interest on the control of the velocity of propagation of light in media there is an increasing interest to possible practical applications of this method. In this paper an overview about the fundamentals, the limits of Slow- and Fast-Light systems especially based on SBS and achieved experimental results so far was given. Thereby methods for an application in optical fiber networks were of special interest.

## ACKNOWLEDGMENT

We gratefully acknowledge the loan of the equipment from C. Schaeffer from the TU-Dresden and K. Buse from the University in Bonn and the help of J. Klinger from the Hochschule fuer Telekommunikation Leipzig.

## REFERENCES

- [1] P. Bernasconi, J. E. Simsarian, J. Gripp, M. Dülk, and D. T. Neilson, "Toward Optical Packet Switching," *Photonics Spectra*, pp. 4-92, March 2006.
- [2] *Journ. of Lightw. Technol.* (Special Issue on Optical Networks), vol. 18, Dec. 2000.
- [3] N. Nagatsu, "Photonic Network Design Issues and Applications to the IP Backbone," *Journ. of Lightw. Technol.*, vol. 18, no. 12, pp. 2010-2018, Dec. 2000.
- [4] C. J. Chang-Hasnain, P.-C. Ku, J. Kim, and S.-L. Chuang, "Variable Optical Buffer Using Slow Light in Semiconductor Nanostructures," *Proc. IEEE*, vol. 91, pp. 1884-1897, 2003.
- [5] M. S. Rasras et al., "Integrated Resonance-Enhanced Variable Optical Delay Lines," *IEEE Photon. Technol. Lett.*, vol. 17, no. 4, pp. 834-836, April 2005.
- [6] F. Xia, L. Sekaric, and Y. Vlasov, "Ultracompact Optical Buffers on a Silicon Chip," *Nature Photonics*, vol. 1, pp. 65-71, 2006.
- [7] D. J. Gauthier, A. L. Gaeta, and R. W. Boyd, "Slow Light; From Basics to Future Aspects," *Photonics Spectra*, pp. 44-50, March 2006.
- [8] S. E. Harris, J. E. Field, and A. Imamoglu, "Nonlinear Optical Processes Using Electromagnetically Induced Transparency," *Phys. Rev. Lett.*, vol. 64, no. 10, pp. 1107-1110, March 1990.
- [9] M. M. Kash et al., "Ultraslow Group Velocity and Enhanced Nonlinear Optical Effects in a Coherently Driven Hot Atomic Gas," *Phys. Rev. Lett.*, vol. 82, no. 26, pp. 5229-5232, June 1999.
- [10] L. V. Hau, S. E. Harris, Z. Dutton, and C. H. Behroozi, "Light Speed Reduction to 17 meters per second in an Ultracold Atomic Gas," *Nature*, vol. 397, pp. 594-598, 1999.
- [11] P. C. Ku et al., "Slow Light in Semiconductor Quantum Wells," *Opt. Lett.*, vol. 29, no. 19, pp. 2291-2293, Oct. 2004.
- [12] M. van der Poel, J. Mørk, and J. M. Hvam, "Controllable Delay of Ultrashort Pulses in a Quantum Dot Optical Amplifier," *Opt. Exp.*, vol. 13, no. 20, pp. 8032-8037, Oct. 2005.
- [13] H. Gersen et al., "Real-Space Observation of Ultraslow Light in Photonic Crystal Waveguides," *Phys. Rev. Lett.*, vol. 94, no. 7, pp. 073903-1-073903-4, 2005.
- [14] N. N. Lepeshkin, A. Schweinsberg, M. S. Bigelow, G. Gehring, R. W. Boyd, "Slow and Fast Light Propagation in Erbium Doped Fiber," in *Proc. of QELS'05*, Baltimore, USA, May 2005, QTuC3.
- [15] A. V. Uskov, F. G. Sedgwick, and C. J. Chang-Hasnain, "Delay Limit of Slow Light in Semiconductor Optical Amplifiers," *IEEE Photon. Technol. Lett.*, vol. 18, no. 6, pp. 731-733, March 2006.
- [16] J. E. Sharping, Y. Okawachi, J. van Howe, C. Xu and A. L. Gaeta, "All-Optical Tunable, Nanosecond Delay Using Wavelength Conversion and Fiber Dispersion," in *Proc. of CLEO 2005*, Long Beach, USA, 2005, CTuT1.
- [17] J. E. Sharping, Y. Okawachi, and A. L. Gaeta, "Wide Bandwidth Slow Light Using a Raman Fiber Amplifier," *Opt. Exp.*, vol. 13, no. 16, pp. 6092-6098, Aug. 2005.
- [18] Y. Okawachi et al., "Tunable All-Optical Delays via Brillouin Slow Light in an Optical Fiber," *Phys. Rev. Lett.*, vol. 94, 2005, 153902.
- [19] M. G. Herraez, K. Y. Song, and L. Thévenaz, "Arbitrary-Bandwidth Brillouin Slow Light in Optical Fibers," *Opt. Exp.*, vol. 14, no. 4, pp. 1395-1400, Feb. 2006.
- [20] T. Schneider, *Nonlinear Optics in Telecommunications*, Springer, Berlin, New York, 2004.
- [21] Z. Zhu et al., "Numerical Study of All-Optical Slow-Light Delays via Stimulated Brillouin Scattering in an Optical Fiber," *J. Opt. Soc. Am. B*, vol. 22, no. 11, pp. 2378-2384, Nov. 2005.
- [22] K. S. Abedin, "Stimulated Scattering in Singlemode Tellurite Glass Fiber," *Opt. Exp.*, vol. 14, no. 24, pp. 11766-11772, Nov. 2006.
- [23] C. Florea, M. Bashkansky, Z. Dutton, J. Sanghera, P. Pureza, and I. Aggarwal, "Stimulated Brillouin Scattering in Single-Mode As<sub>2</sub>S<sub>3</sub> and As<sub>2</sub>Se<sub>3</sub> Chalcogenide Fibers," *Opt. Exp.*, vol. 14, no. 25, pp. 12063-12070, Nov. 2006.
- [24] A. M. C. Dawes, Z. Zhu, and D. J. Gauthier, "Improving the Bandwidth of SBS-Based Slow-Light Delay," in *Proc. of CLEO'06*, USA, 2006, CThW1.
- [25] Z. Zhu, A. M. C. Dawes, D. J. Gauthier, L. Zhang, and A. E. Willner, "12-GHz-Bandwidth SBS Slow Light in Optical Fibers," in *Proc. of OFC'06*, USA, 2006, PDP1.
- [26] E. Shumakher, N. Orbach, A. Nevet, D. Dahan, and G. Eisenstein, "On the Balance Between Delay, Bandwidth and Signal Distortion in Slow Light Systems Based on Stimulated Brillouin Scattering in Optical Fibers," *Opt. Exp.*, vol. 14, no. 13, pp. 5877-5884, June 2006.
- [27] T. Schneider, M. Junker, and K.-U. Lauterbach, "Potential Ultrawide Slow-Light Bandwidth enhancement," *Opt. Exp.*, vol. 14, no. 23, pp. 11082-11087, Nov. 2006.
- [28] K. Y. Song, M. G. Herraez, and L. Thévenaz, "Long Optically Controlled Delays in Optical Fibers," *Opt. Lett.*, vol. 30, no. 14, pp. 1782-1784, July 2005.
- [29] T. Schneider, M. Junker, K.-U. Lauterbach, and R. Henker, "Distortion Reduction in Cascaded Slow Light Delays," *Electr. Lett.*, vol. 42, no. 19, pp. 1110-1112, Sept. 2006.
- [30] T. Schneider, M. Junker, and K.-U. Lauterbach, "Time Delay Enhancement in Stimulated Brillouin Scattering Based Slow Light Systems," *Opt. Lett.*, vol. 32, no. 3, pp. 220-223, Feb. 2007.
- [31] T. Schneider, R. Henker, K.-U. Lauterbach, and M. Junker, "Adapting the Brillouin Spectrum for Slow Light Delays," *Electr. Lett.*, in press.
- [32] T. Schneider, R. Henker, M. Junker, and K.-U. Lauterbach, "Comparison of Delay Enhancement Mechanisms for SBS-Based Slow Light Systems," *Opt. Exp.*, unpublished.
- [33] R. W. Boyd, D. J. Gauthier, A. L. Gaeta, and A. E. Willner, "Limits on the Time Delay Induced by Slow-Light Propagation," in *Proc. of QELS'05*, 2005, QTuC1.
- [34] J. B. Khurgin, "Performance Limits of Delay Lines Based on Optical Amplifiers," *Opt. Lett.*, vol. 31, no. 7, pp. 948-950, 2006.