

---

# Small Wind Turbines: Specification, Design, and Economic Evaluation

---

Jakub Bukala, Krzysztof Damaziak,  
Krzysztof Kroszczynski, Jerzy Malachowski,  
Tomasz Szafranski, Michal Tomaszewski,  
Hamid R. Karimi, Krzysztof Jozwik,  
Maciej Karczewski and Krzysztof Sobczak

Additional information is available at the end of the chapter

<http://dx.doi.org/10.5772/62821>

---

## Abstract

In this work, we consider various aspects of small wind turbines' (SWTs) design and operation. First, an extensive literature study is presented by considering SWTs specification, market statistics, the smart grid, and the prosumer concepts as well as the most important parameters affecting the efficiency of wind turbines. Then, both the literature review and series of coupled numerical simulations investigating impact of the chosen design solutions on small wind turbine operation are performed. It allowed objective evaluation of different design approaches, which in turn enabled the systematic identification of actual limitations as well as the opportunities for specific design solutions of SWTs: horizontal axis wind turbines (HAWTs) and vertical axis wind turbines (VAWTs); the rotor position in relation to the tower (upwind vs. downwind); and diffuser-augmented wind turbine (DAWT). Additionally, an economic evaluation is carried with the use of an advanced numerical Weather Research & Forecasting (WRF) model. It is shown that auxiliary power generation using privately owned SWTs can be an economically viable option. Finally, a set of design goals for future SWTs is formulated based on the performed numerical analyses.

**Keywords:** Small wind turbine, Design, Economy, Evaluation, Market

## 1. Introduction

Small wind turbines (SWTs) are a distinct and separate group of devices developed within the wind energy sector. According to the IEC 61400-2 standard, SWTs are characterized by a rotor area of  $<200\text{m}^2$  and rated power below 50kW [1]. Wind power plants in this category are generally designed for small and individual customers such as households, farms, weather stations, road signalization, and advertising systems. SWTs offer a promising alternative for many remote electrical uses where, given a set of site evaluation criteria, the wind resources can be identified as beneficial, both as stand-alone applications and in combination with other energy conversion technologies such as photovoltaic, small hydro or diesel engines.

The quantity of SWTs operating worldwide grows every year. In 2012, the total number of such devices was approximately 800,000 worldwide [2] with the growth of about 10%. The majority of SWTs (about 70%) are located in China, where the highest number of new installed units in 2012 was also noted. The second biggest market of SWTs is USA, where around 155,000 SWTs are operating at the time this document is prepared. In Europe, the leader is the United Kingdom: 23,500 units, followed by Germany: 10,000 units, Spain: 7020 units, and Poland: 3200 units. Total SWT generation capacity installed in 2012 was equal to around 678 MW (576 MW in 2011). The majority of world's capacity (85%) belongs to three countries: China (274 MW), USA (216 MW), and UK (83.7 MW). Unfortunately, developing countries play a minor role in small wind turbine industry. Electrical capacity growth in 2013 was small, with just 90 MW installed across Africa, for a cumulative total of 1255 MW. It is exceptionally regrettable considering enormous wind power potential (best around the coasts and in the eastern highlands of the African continent) [2]. A global forecast concerning SWTs installed capacity in years 2009–2020 is presented in **Figure 1**.

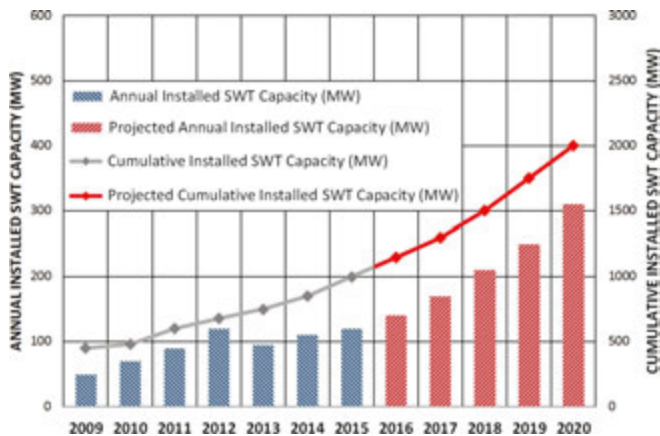

**Figure 1.** SWT installed capacity world market forecast for 2009–2020 [2].

The development and dissemination of SWTs involves great expectations in the field of eco-energy production. Some opinions suggest that without the dissemination of SWTs, the fulfillment of legal requirements for energy efficiency and energy production from renewable sources will be relatively difficult. In particular, in the developing countries, small wind turbine sector can efficiently contribute to provide electricity to millions of people in rural areas. In order to create a positive outcome, a big challenge awaits not only the authors of laws supporting investments in SWTs, but also engineers and scientists who should propose design solutions addressing the real issues found in the small wind turbine energy sector (aerodynamics: ill-optimized blade often using trends and observations from large HAWTs, poorly addressed issue of local wind resources abundance; structural: different nature of loads experienced by SWTs, little care given to weight optimization; conversion/control: seldom usage of active regulation methods, such as rpm control to expand operational margin of the SWTs, little attention given to match turbine's mechanical power capability with that of a generator; economic: lack of cost optimized SWTs) [3].

The wide prevalence of SWTs and the emergence of the so-called "prosumers" within the electrical grid (the Smart Grid concept) are believed to be one of the biggest factors changing the way that the power companies will deliver service over the next decade. This qualitative change may result in a reduction of transmission losses and make the electricity infrastructure more flexible and secure. The specialists agree that work on the design and architecture of the future grid is as important as the work on the technologies and products that would realize a smart grid vision, for example, SWTs being a part of electricity network [4]. The above motivates to devote more effort to the field of modern SWTs development.

In the small wind turbine market, the return on investment (ROI) is one of the most important factors determining the turbine's validity [5]. Having the above in mind, it has become a challenge for many designers and research facilities to develop a small wind turbine design which would be competitive with other renewable energy sources. For this to be possible, it would have to incorporate a number of factors: high efficiency, sufficient longevity, low installation, and maintenance costs. Having above in mind, it has been concluded that SWTs should be characterized by the lowest possible price, while maintaining relatively high efficiency as well as satisfying reliability and maintenance parameters.

## 2. SWT design solutions

This section presents both the literature investigation including manufactures data and independent expertise as well as series of coupled numerical simulations (computational fluid dynamics (CFD), Finite Element Method (FEM), multi-body), investigating impact of the chosen design solutions on small wind turbine operation. It allowed objective evaluation of different design approaches (advantages and disadvantages), which in turn enabled the systematic identification of actual limitations as well as the opportunities for specific design solutions of SWTs: horizontal axis wind turbines (HAWTs) and vertical axis wind turbines (VAWTs); the rotor position in relation to the tower (upwind vs. downwind); and the addition of a duct that encapsulates the rotor (diffusor-augmented wind turbine—DAWT).

## 2.1. Horizontal and vertical axis SWTs

Wind turbines in general can be divided into two major groups based on the position of rotor axis of revolution: HAWTs and VAWTs [6].

HAWTs are currently the vast majority of installed solutions worldwide. Consequently, close to 75% of SWTs are HAWTs. That is due to their high efficiency in relation to low installation and maintenance costs. Apart from the unconventional solutions and one- and two-bladed configurations, the classic three-bladed layout is the default choice with a 99% market share of all operating HAWTs [7]. Three blades is the lowest blade count which allows for easier management of centrifugal body forces. Some small turbines incorporate an increased amount of blades, which may improve aerodynamic efficiency slightly, but most often the added mass and material cost outweigh any benefits gained.

VAWTs are the earliest examples of harnessing the energy of the wind. These early machines were primarily based on a drag force as the mechanics to turn the turbine's working section. Some modern designs try to re-invent the concept, but the efficiency is generally unsatisfactory because of the limited tip speed ratio. Modern-day VAWTs most often use the aerodynamic principles of lift force to work, with Darrieus wind turbines being a good example. Some of the marketed advantages of VAWTs over the classic horizontal designs are as follows: easier maintenance thanks to the generator and the gearbox being placed near the ground, low cut-in wind speeds and no need for yaw mechanisms. In practice, maintenance and operational costs are similar because of the high loads on the bottom bearing, efficiency in converting wind kinetic energy into a mechanical power is relatively low for low wind speeds and response to an often changing wind direction dominated by turbulence is poor [7, 8]. Nevertheless, VAWTs are a popular choice for urban wind environments and are seeing some optimization research with advanced evolutionary algorithms aimed at raising the overall performance of these designs [9].

## 2.2. Shrouded SWTs

An interesting design solution for HAWT turbines is the addition of a circular duct that encapsulates the rotor. Such turbines have a number of commercial and scientific designations, such as DAWT, wind lens, compact wind acceleration turbine (CWAT). Attempts to add a shroud in order to stabilize and accelerate the flow through a turbine have been reported nearly 150 years ago. An invention proposed by Ernest Bollée, patented in 1868, was an American style multiblade wind turbine with a stator in the form of a shroud. After decades of stagnancy, shrouded turbines have seen a major interest increase in recent years with many academic and industrial centers proposing mechanically and aerodynamically optimized solutions which are said to be vastly superior to non-shrouded designs. The influence of the shroud on the air flow has been proven to be beneficial in numerous wind tunnel tests [10, 11], but little is available on the performance of such turbines in real outside conditions. What is more, the added diffuser is often expensive due to the amount of material used and the added mass puts more stress on the towers foundation and hinders the operation of the yaw system.

The concept of Framed Light Shell Diffuser (**Figure 2**) was created as an attempt to lighten the diffuser made of glass fiber composites which are the most commonly used materials for such applications nowadays. Geometrical shape of the diffuser was developed based on CFD simulations considering turbine efficiency optimization for low wind speed conditions. The authors focused on developing an overall structural design, as well as detailed technical solutions (stiffer struts, connecting rods, material forming issues). Subsequently, static structural finite element analysis was performed in order to assess the stiffness and stress distribution based on load conditions in the form of pressure field from the CFD analysis and gravitational forces. Obtained results lead to a conclusion that designed aluminum shell frame diffuser may be an alternative for the composite diffuser. Moreover, the developed structure is characterized by lower mass and comparable stiffness to its composite counterpart. It is worth mentioning that lighter diffusers allow use of lighter supporting structures, such as towers or guy-wired masts. This fact may contribute to lowering the overall costs of future SWTs and could be very beneficial for the privately owned small wind turbine market.

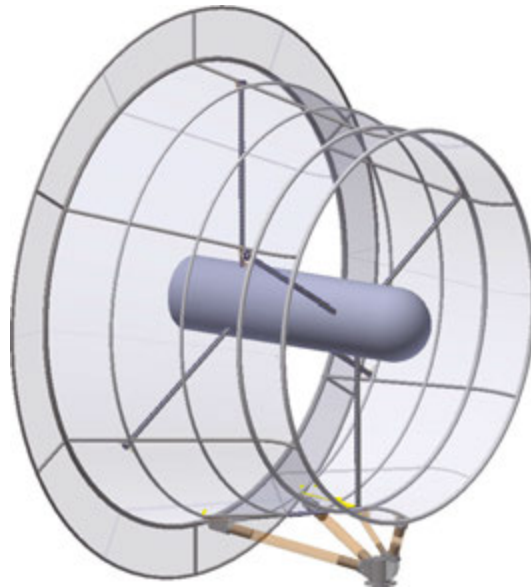

**Figure 2.** Framed Light Shell Diffuser concept for SWT.

### 2.3. Upwind vs. downwind SWTs

One of the fundamental distinguishing factors in horizontal wind turbines is the rotor position in relation to the tower (see **Figure 3**). Today market is dominated by upwind rotors: relative to the wind, their rotor is located in front of the tower (windward) (**Figure 3a**), while downwind rotors are behind the tower (leeward) (**Figure 3b**) [12].

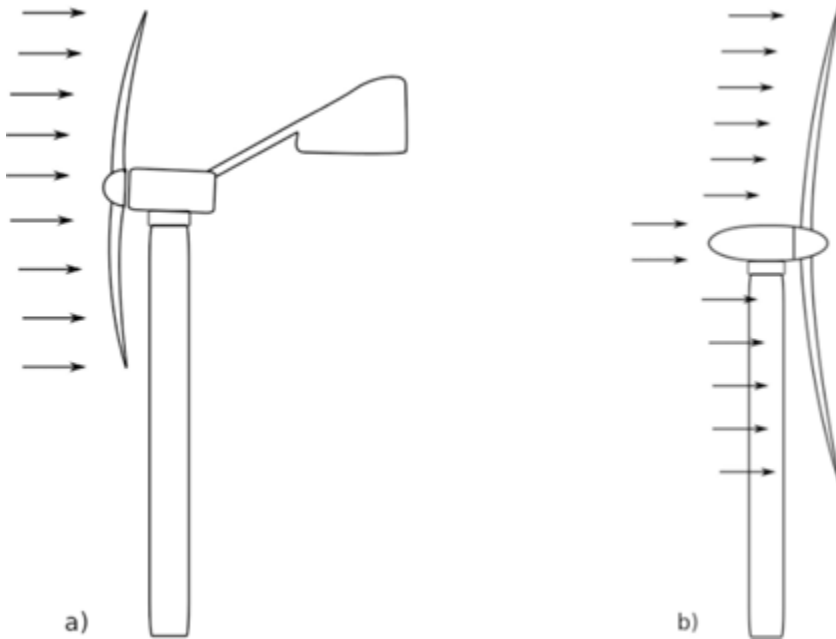

**Figure 3.** Upwind (a) and downwind (b) wind turbines.

In upwind design solution, the rotor is in the front of the unit (facing the wind) and it is characterized by higher efficiency due to the reduced tower impact on wind inducted at the working section. Unlike upwind, the downwind turbines experience a different inlet wind profile effectively changed by the development of a boundary layer on a nacelle and by the formation of wakes in the aerodynamic trail behind the mast. In upwind designs, the rotor needs to be made rather inflexible and placed at some distance from the tower to avoid collision. What is more, those are not self-aligning in the direction of the wind, and therefore, they need a tail vane or a yaw system to keep the rotor facing the wind.

In downwind turbines, the rotor is on the back side of the turbine (the lee side of the tower). Their main advantages are that they may be built without a yaw mechanism and the rotor may be made more flexible (since there is no danger of a tower strike). This may be an advantage both in regards to weight and the structural dynamics of the machine. Therefore, the basic advantage of the downwind machine is that theoretically, it may be built simpler and lighter than an upwind machine. Downwind turbines generally have lower aerodynamic efficiency, and the fluctuation in the wind power due to the rotor passing through the wind shade of the tower may give more fatigue loads on the turbine than those with an upwind design. Although the upwind type is more popular than the other one, the advantage that the downwind configuration can face the wind automatically makes them much more promising for SWTs due to its simplicity.

Using the methodology of aero-, servo-, elastic-coupled numerical analyses, the authors carried out analysis of small wind turbine behavior in terms of upwind vs. downwind SWT comparison. It is worth pointing out that the relative low cost of such research methods is a great advantage in comparison to real experiments (e.g., wind tunnel tests) [13].

The first set of the obtained results concerns the dynamic response of the simulated variants in terms of rapidly changing wind speed conditions. Case one was here the IEC 61400-1 direction-change condition [14]. Both considered turbine variants have proved to be capable of quick and precise nacelle turn during the changing direction, event and it can be stated that both design solutions work properly and similarly in this case. The upwind variant of the small wind turbine proves to have 5% higher efficiency than the downwind variant, which in turn resulted in a 13% higher energy output in economic analysis. For the 3 kW machine, the downwind variant should be at least 1200 USD cheaper than the upwind small wind turbine to be economically valid (by the application of lighter and cheaper materials, deflective blades, etc.); on the contrary, it is more likely to equip the small wind turbine in a tail vain having additional 1200 USD. The biggest disadvantage of the downwind design variant is the presence of significant fluctuations of momentums in rotor blades and forces on the top of turbine tower, which may cause a real danger of fatigue damage in the turbine construction as well as the risk of resonance [15].

#### **2.4. Other SWTs designs**

Other design solutions that can be found in SWT applications or concepts are, that is, as follows: two-blade, single-blade turbines with a counterweigh, multiblade rotors, Venturi design turbines, Magnus effect turbines, multi-rotor solutions, H-type turbines, Darrieus–Savonius hybrid, Tornado/Jet/Vortex/Spiral airfoil, Fuller's design (bladeless—Tesla like), Pawlak's design, airborne concepts, and other unconventional solutions.

The main driver for multiblade (up to three) turbine development is the fact that aerodynamic efficiency increases with the number of blades. Increasing the number of blades from one to two yields a six percent increase in aerodynamic efficiency, whereas increasing the blade count from two to three yields only an additional three percent in efficiency [16].

Extraction of wind energy by a single rotor leaves a substantial amount of power unrecovered. To use this remaining potential, a two-stage wind turbine was proposed. Contra-rotating wind turbines possessing two co-axial rotors can theoretically gain up to 40% more energy from a given swept area as compared to a single-rotor turbine. Contra-rotating turbines require a generator tailored for this system in order to avoid expensive and impractical placement of the second generator on rotor-nacelle assembly (RNA) to convert energy from the additional rotor. In fact, the twin shaft technology of co-axial rotors presents a possibility to increase the rotation speed of the electrical generator by summing up the relative velocities of the rotor and stator. The main drawbacks of two-stage turbines are an increased interaction between the rotors posing problems from aero-mechanical point of view and the additional costs associated with the installation of the second stage and a more sophisticated generator [17].

The Savonius rotor is a self-starting, high-torque wind turbine. It may be used alone or to jump start the Darrieus rotor, a high-efficiency rotor, but with a limited capability to initiate operation on its own. This combination is presented as an effective design that combines the advantages of both designs [18].

The Magnus effect is the commonly observed effect in which a spinning ball (or cylinder) curves away from its principal flight path (a force perpendicular to the direction of movement, acting on the rotating cylinder or other rotary body, moving relative to the fluid). This makes a range of potential advantages with respect to traditional blade wind turbine. Radial cylinder location is analogous to wind wheel blades with horizontal axe. The basic advantages are said to be seen at low, but the most repeated wind velocities 2–6 m/s, at which blade wind turbines are not effective [19].

## 2.5. SWT's blades

The blades are the components, which interact with wind and are designed to maximize the turbine efficiency. Blades are made from light materials, such as glass- or aluminum-based fiber-reinforced plastics, possessing good resistance to wear and tear. The fibers are incorporated in a matrix of polyester, epoxy resin, or vinyl ester constituting two shells kept together and strengthened by an internal matrix. The external surface of the blade is covered with a layer of colored gel to prevent ageing of composite material due to ultraviolet radiation [6, 7, 9].

A hollow shell corresponding to the defined blade envelope clearly provides a simple, efficient structure to resist flexural and torsional loads, and some blade manufacturers adopt this form of construction. The hollow shell structure defined by the airfoil section is not very efficient in resisting out-of-plane shear loads, so these are catered for by the inclusion of one or more shear webs oriented perpendicular to the blade chord.

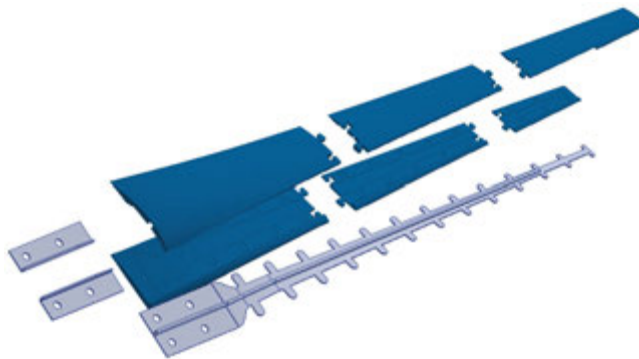

**Figure 4.** 3D printed ABS polymer-based SWT blade with a stiffening core made of steel.

Five different materials were considered in terms of turbine blade optimization: steel, aluminum alloy, glass fiber composite, carbon fiber composite, and ABS polymer for three-dimensional (3D) printing (**Figure 4**). Blades made of all listed materials have fulfilled the strength



criterion (stresses values generated by maximum loads did not crossed yield or fracture). Analysis revealed that the best material in terms of mass and stiffness is the carbon composite. Unfortunately, this material is very expensive and was opted with in order to keep SWT price reasonably low. Metal-based materials are characterized by very high stiffness, which reduces the blade tip deflection; however, the mass of the blade was too high in this case. What is more, a relatively high stiffness was a direct cause of relatively high stress values. Those values have raised justified questions on the fatigue toughness of the SWT. The ABS polymer is the cheapest and the lightest one of all mentioned. It is also the best choice from the manufacturing point of view. Unfortunately, it is also the most flexible material, producing high blade tip deflections even after the introduction of stiffening core made of steel (**Figure 5**).

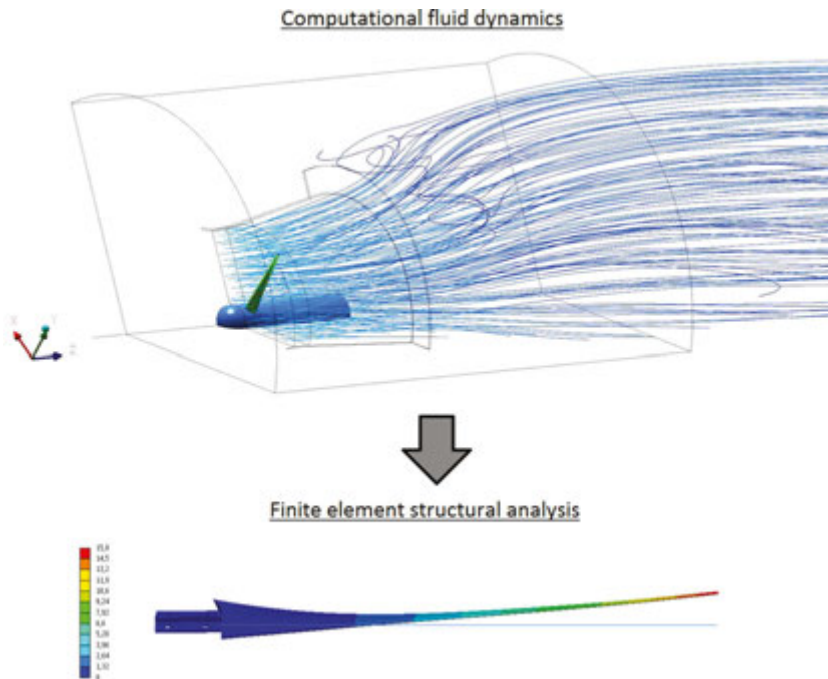

Figure 5. SWT blade deflection (ABS 3D printed coating with a steel core).

## 2.6. SWT's generators

SWTs are usually equipped with synchronous generators operating at variable angular speeds based on permanent magnets (e.g., neodymium magnets) [20]. It is a design solution which can contribute to meeting the requirements of efficient operation. Working principles of the variable speed generator determine many other aspects of the wind turbine operation including, for example, a tremendously increased annual energy production (AEP) in comparison with equal-power fixed pitch, fixed speed turbines.



**Figure 6.** Roof-mounted SWT equipped with the diffuser.

SWTs typically operate in autonomous systems without connection to the grid, in which they directly power heating and other loads that do not require stable electric parameters, dictated by economic issues. Potential expenditure related to connecting the SWT to the electrical grid exceeds the usual financial benefits of possible income from selling energy produced. The other aspect is the fact that SWTs are generally simple devices and they are rarely equipped with sophisticated control systems such as blade pitch mechanisms.

This type of generator produces alternating current (AC), which must be rectified to direct current (DC) by means of a simple bridge rectifier. Similar to solar photovoltaic (PV) systems, the DC voltage allows the use of these turbines for battery charging. For in-battery charging systems, a charge controller is added to prevent the battery from overcharging. A dump load

is required to protect the inverter from overvoltage and to prevent the turbine from over-speeding [21].

### 2.7. SWT's supporting structures

The SWT is usually placed on a pole, preferably higher than 15 m, to lessen the impact of turbulent, sheared winds forming in close proximity to the ground. Utility-scale wind turbine towers are mostly of tubular type. In case of SWTs, tubular type towers are also popular; however, guyed lattice towers are also used. The tilt-up poles/towers are very popular since they are easy to install and offer good accessibility for maintenance and repair. Tubular towers are usually made of rolled steel, although sometimes reinforced concrete is used [9].

Rooftop-mounted turbines are yet another option. Such turbines are directly installed on a building. Both vertical and horizontal axis turbines can be mounted in such a way (**Figure 6**), but they might be subject to slightly different wind profiles being inducted at the rotor [21]. Particularly important for roof-mounted turbines is the identification of flow separations due to rooftop edges. Such flow structures not only influence the production efficiency but may be a source of unwanted loads that are difficult to control.

## 3. SWT's economic evaluation

The investment in SWTs is more often made by private individuals in order to partially fulfill residential household demand for electricity or to produce hot tap water. However, practice shows that a large portion of those who have decided to build a backyard wind turbine is disappointed with the actual amount of energy produced by it. This is mainly due to the promotion of inaccurate, overstated, or even incorrect information on the projected turbine's power output by manufacturers or installers. This reduces public confidence in the legitimacy of this sort of economic investment, thus slowing down the development of this industry sector [22, 23].

Numerical weather prediction (NWP) simulations over the span of year 2013, covering the whole area of Poland, were carried out. The purpose of these forecasts was to establish a reliable and accurate wind resource atlas for approximate AEP of small wind turbine systems. Long-term wind speed forecasting has been used with success for utility-scaled wind farms. This accounts not only for planned sites but also operational power plants, where weather forecasting is used constantly for setting up advanced control schemes or predicting suitable time windows for planned maintenance [24].

Calculation of meteorological parameters was performed using the non-hydrostatic mesoscale Weather Research & Forecasting (WRF) model. WRF is designed both for operational forecasting and atmospheric research use. It enables an atmospheric phenomena simulation for scales ranging from thousands of kilometers to single meters. The model contains several capabilities, important from the research point of view, such as: 3D data control with initial data and model results correction possibilities using aerological, radar and satellite measure-

ments; multilayer ground modeling; humidity cycle; vegetation; cloud cover and precipitation parameterization including water phase state; radiation transport processes; and boundary layer with turbulent vertical transport. These modules are responsible for the parameterization of physical phenomena occurring in the atmosphere. The boundary layer area of intensive surface radiative forcing and mechanical forcing is an important part of the simulated phenomena. Mechanical forcing is determined by orography, roughness, and cover. Radiative forcing is defined by albedo and thermal capacity of the surface. The parameters are determined by the ratio of land to water area; vegetation and its status; irradiation depending on location and inclination. Determination of these factors was of importance because the boundary layer close to the surface is the area associated with the presented studies.

The data used in the study covered the period of 1 year (01.01.2013-31.12.2013). The input data of the WRF came from the archive of the global forecast system (GFS). These were obtained from the National SOO Science and Training Resource Centre (NWS SOO/STRC). The model was run for each day and for each main synoptic term. Two grids with spatial resolution of 36 and 12 km were used. The simulation domain included a selected area of Europe as shown in **Figure 7**. Forecast modeling time was set equal to 24 h with a 1 h data sampling rate. Results for each 24-h period were obtained in a five-dimensional set of prognostic parameters fields. This set includes, among others: pressure values, geopotential, temperature, and three-dimensional wind fields [16]. Wind speed data averaged over a 60 min period have been said to be useful for long-term energy yield predictions for SWTs [25].

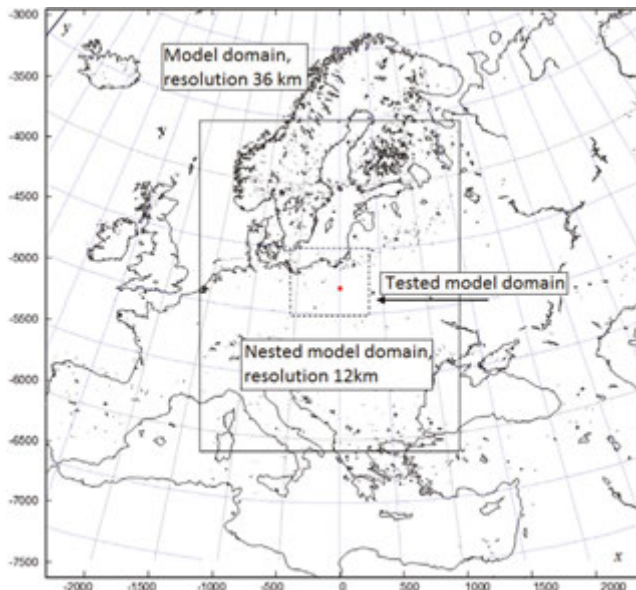

**Figure 7.** WRF model domains—36 and 12 km grid [23].

A randomly chosen location in model domain was a rural region neighboring a small town called Sokolow Malopolski in the Voivodship of Sub-Carpathia. It is characterized with rather typical rural wind speed conditions. Many of the houses built in the region are solitary and surrounded by open grass or farm fields, thus producing a suspected low ground roughness rate. Such households could potentially benefit from an auxiliary power or heating source in the form of a small wind turbine.

Calculations of the power output were performed using the following formula:

$$E = \sum_{i=1}^n \begin{cases} \frac{1}{2} A \rho \eta(v_i) v_i^3 h & P_r > \frac{1}{2} A \rho \eta(v_i) v_i^3 \\ P_r h & P_r \leq \frac{1}{2} A \rho \eta(v_i) v_i^3 \end{cases} \quad (1)$$

where:  $E$  is the estimated total energy generated throughout the test period,  $n$  is the number of samples,  $h$  is the sample duration (1 h),  $v_i$  is the wind speed for sample  $i$ ,  $A$  is the swept area of a given turbine,  $\rho_i$  is the air density for sample  $i$ ,  $\eta(v_i)$  wind turbine efficiency at given tip-speed ratio (TSR) and  $P_r$  is the turbine rated power.

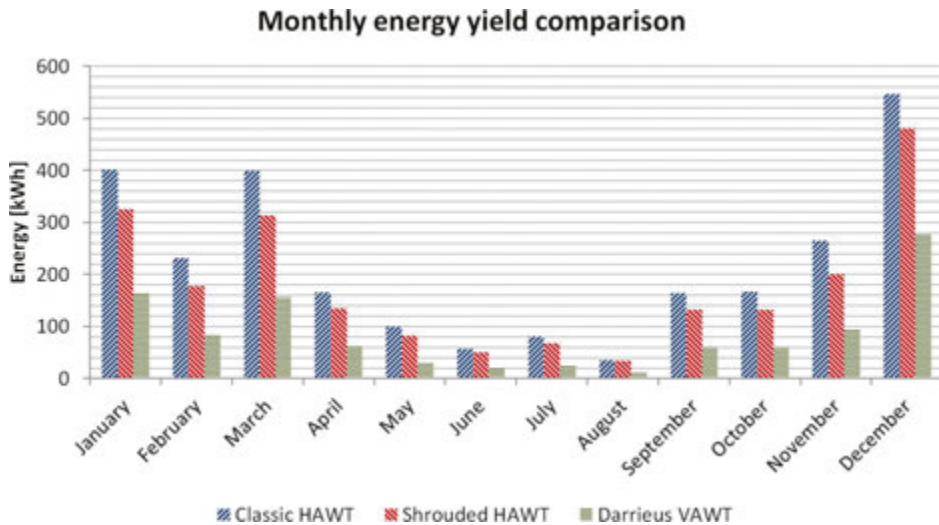

Figure 8. Monthly energy output for the chosen turbines [23].

### 3.1. HAWT, VAWT, and DAWT comparison

Three types of SWTs were chosen to be compared in terms of their productivity and cost-effectiveness. The first is a typical three-bladed HAWT design. The second is an aerodynamically complex, shrouded HAWT. The third is the Darrieus-type VAWT. All the turbine

characteristics, such as power curves, price, swept area, were taken from very popular, commercially proven designs. For the results to be meaningful, all the chosen turbines have a similar rated power of around 3 kW.

The outcome of the performed calculations is shown in **Figure 8** and compared in **Table 1**. When estimating the investment return period, the price for energy supplied (power supply) was established at 0.2 \$/kWh. Maintenance and any additional costs associated with turbine operation are assumed to be the same for all three systems and are therefore neglected.

	Energy produced (kWh/year)	ROI (years)
Classic HAWT	2610	28+
Shrouded HAWT	2126	31+
Darrieus VAWT	1036	137+

**Table 1.** Chosen designs economic comparison [16].

The difference in monthly power generation is clearly visible with the majority of energy being produced during the windy winter months. Any needed maintenance or routine inspections should be carried out during calm summer months. Such a discrepancy in electricity generation raises the problem of continuous power supply.

For the chosen localization, the classic three-bladed HAWT proved to be the most cost-effective design of those taken into account, even though it had the lowest rated power. In theory, the advanced construction of the shrouded HAWT turbine allowed for a very high theoretical efficiency. In practice, because of its small rotor diameter it proved to be slightly inferior to the classic layout with a larger rotor. Moreover, the shroud is likely to put additional strain on the tower due to added mass and increased aerodynamic drag, possibly increasing the maintenance costs. Snowfall and icing of the shroud could lower the operational availability and introduce the need for deicing. The chosen Darrieus vertical wind turbine was the worst design in the terms of cost-effectiveness. Very high system costs and low efficiency in relation to rotor size led to the return period being unacceptably long [23].

### 3.2. Investigation of parameters influencing the efficiency of SWTs

Three cases will be carried out in order to find the factors which have the highest impact on the estimated electrical power generation. Case one investigates the difference between estimated one with a theoretical, constant efficiency turbine and a popular, commercially available, wind turbine using its power curve. The second case estimates the generated amount of energy based on three types of wind data for a randomly chosen site. In this case, calculations were performed using a yearly mean wind speed, discretized meteorological data and the Weibull wind speed distribution function. The third case shows the difference of estimated energy production for three tower heights: 10, 20, and 30 m [22]. Calculations of the power outputs were performed using formula (1.).

The turbine chosen for the analyses is the Evance R9000, which is a popular small wind turbine design with a high market share, especially in the UK. It is a 5 kW turbine, with a 5.5-m-radius rotor and a typical, of HAWTs, power curve [26]. Factors such as maintenance and down time were not taken into account. That is due to the fact that the goal for these calculations was to estimate small wind turbine sensitivity to operating parameters such as a tower height, efficiency, and wind data type with which the AEP forecast is modeled.

The estimated energy produced by the Evance R9000 amounted to 7551 kWh, assuming energy cost of 0.2 €/kWh, that is an equivalent of 1510 €. For a 5-year ROI period, without any maintenance or down time, the turbine would have to be priced at around 7500 €; however, in reality, such solutions are roughly priced at 36,500 €. Another aspect worth mentioning is that a yearly demand for energy of typical household is estimated at around 3–4 MWh. Thus, in theory, it would be possible to achieve energy independence. In practice, it would be nearly impossible (the problem arising from high fluctuation of the energy production throughout the year, mentioned in 3.1.1.).

Another very interesting way to present the obtained results is to draw an energy density function on top of the occurring wind speeds. **Figure 9** shows, in blue, the wind speed occurrence rates and, in red, the amount of energy generated from a specific wind speed by the Evance R9000 turbine during the whole year. The shift of the energy density function to the right in respect to wind speed curve is a direct result of the power equation, proportional wind speed cubed Equation (1).

Using Matlab computer software, the maximum likelihood estimate of the Weibull parameters has been established with the *wlbfite* function. The resultant Weibull probability density function is shown in **Figure 9**. Additionally, an arithmetic mean of the wind speed for the given location has been calculated and is equal to around 4.77 m/s. The yearly power generated has been again calculated using the obtained Weibull function and the mean wind speed with the standard Evance9000 power curve. A comparison of the estimated power production based on three different wind data types is presented in **Figure 10**. It is clearly visible that estimating the amount of wind power generation using an arithmetic mean of the wind speed is highly inaccurate. The predicted amount was 4420 kWh which is almost 70% off the amount of energy predicted using the direct method with accurate wind speed data. Energy production estimated with the Weibull function equaled 7932 kWh, which is 5% different from the result obtained using the direct method. This difference is small enough to prove the validity of using the Weibull or Rayleigh distributions for estimating small wind turbine energy production.

Five different calculations of estimated energy output were performed with five different small wind turbine characteristics. The first was performed with an artificial, constant value of 33%. Three characteristics were based on the Evance R9000 power curve including the original curve, one which is offset by +5% and another which is offset by -5% from the original distribution. The fifth one is a hypothetically proposed, small wind turbine curve which has increased efficiency in low wind speeds—STOW (**Figure 11**). The results of the performed calculations are presented in **Figure 12**.

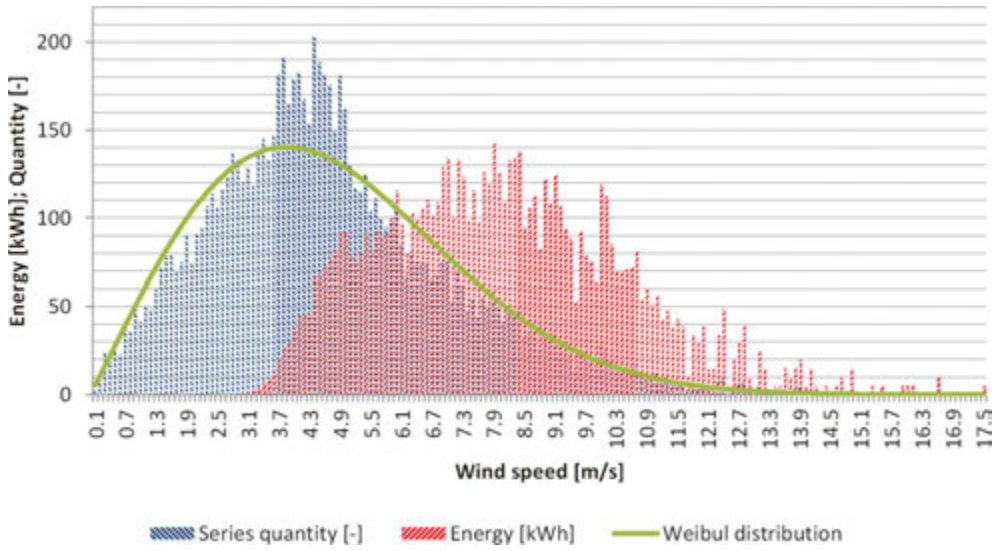

Figure 9. Wind speed distribution, energy distribution, and Weibull function fit ( $c = 5379$ ;  $k = 2023$ ) [22].

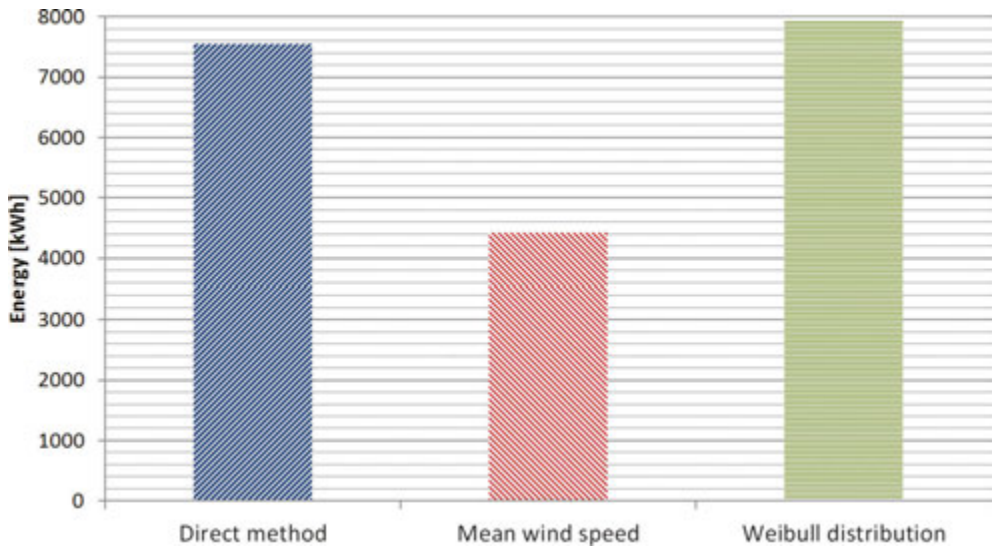

Figure 10. Energy production estimates based on three different wind speed data types [22].



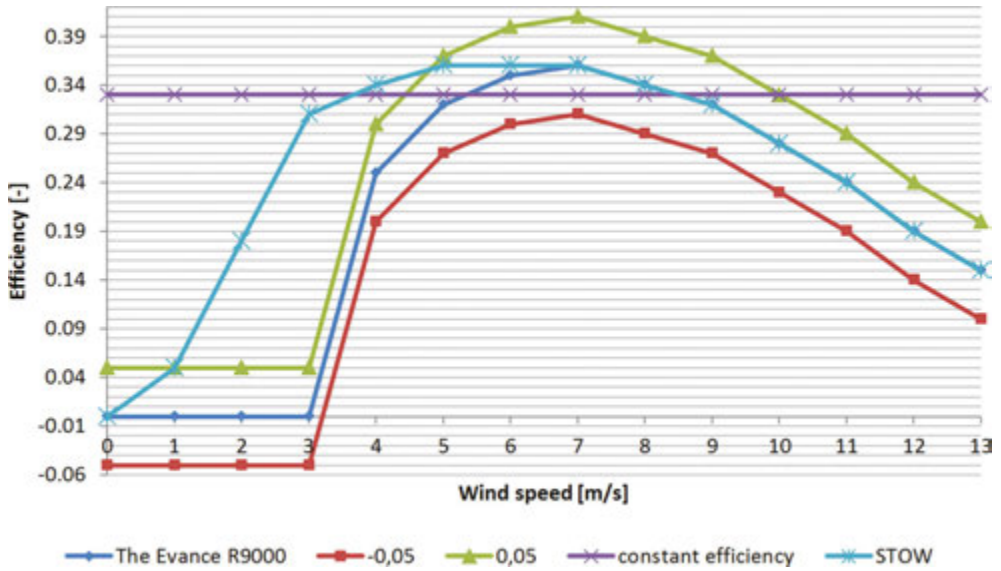

Figure 11. Efficiency curves used for the energy calculations [22].

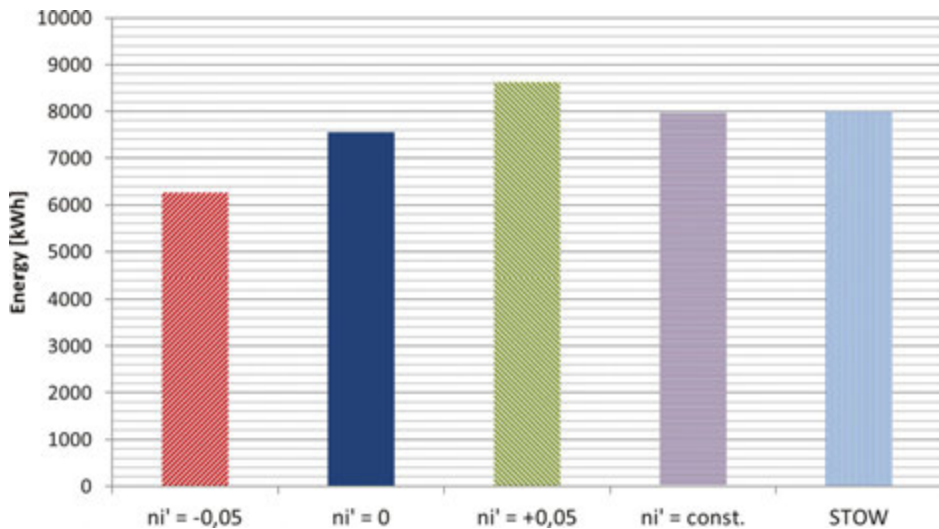
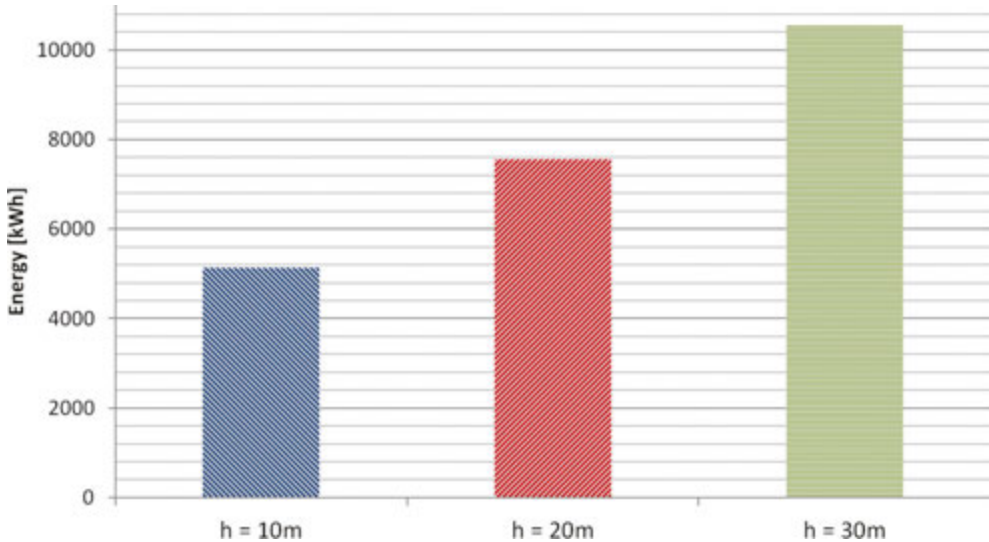

Figure 12. Energy produced by a 5 kW rated turbine with different efficiency curves; the series are tied to the curves presented in Figure 11 [22].

The final investigated small wind turbine parameter was the tower height. Wind speed data were collected at 10 m height. Using the power law with the terrain dependent parameter  $\alpha = 1/7$ , the wind speeds for the whole year have been recalculated for 20 and 30 m heights. The obtained wind speeds were used to estimate the produced power with the standard power curve and are presented in **Figure 13**.



**Figure 13.** Estimated energy generated for different tower height variants (10, 20, and 30 m)—wind speed obtained with the empirical power law [22].

## 4. Summary

Auxiliary power generation using privately owned SWTs can be an economically viable option, but the price of design solutions available on the market is often unreasonably high. Due to the very long ROI period (even for popular and commercially proven designs), it is of great importance for those systems to be installed in areas with above average wind conditions.

Advanced and experimental solutions such as shrouded or VAWTs are an interesting concept, but real efficiency of such designs appears to be virtually equal or even lower to equivalent classic three-bladed turbines. Additionally, the overall size and weight of these systems are increased. This in turn forces the need for sturdier and more expensive towers.

Private investors interested in setting up a green auxiliary power system should be aware of the fact that wind turbines installed inland will be subjected to seasonally changing winds.

To avoid energy waste on AC/DC/AC conversion of electricity, it is advisable to use the generated power for water heating. The use of power banks greatly raises costs of the invest-

ment and is hazardous to the environment, as the used batteries are very difficult to recycle. With the windy winter months, no energy would be wasted as hot water is used constantly during this period of the year.

Most importantly, though, it has been shown that even a major increase in a turbine aerodynamic and overall efficiency will not provide as much additional power as an increased tower height. Aerodynamic optimization of the rotor, use of advanced, light materials, etc. will have a positive outcome in the turbines operation and power output; however, the increased costs of such solutions will undoubtedly result in the same or even longer ROI periods, based on the methodology presented herein. Taking into account all the above, in the authors' opinion, a major focus in developing new small wind turbine solutions should be paid to reducing the price of the final product and mounting the design on a tower as high as it is reasonably, from the aeromechanical and operational safety point of view, economically and legally possible. When establishing the final tower height, numerous aspects associated with it must be taken into account, such as, but not limited to: national construction law, mooring possibilities, space available on site, and the soil type. In short, it is more reasonable to invest in a robust and cheap turbine design and mount it on a high tower. Additionally, the authors' attention was also paid to the fact that optimizing a wind turbine for low speed conditions (4–5 m/s) is economically unjustified as such wind speed does not provide sufficient kinetic energy for the turbine.

## Acknowledgements

The research leading to these results has received funding from the Polish-Norwegian Research Programme operated by the National Centre for Research and Development under the Norwegian Financial Mechanism 2009–2014 in the frame of Project Contract no. Pol-Nor/200957/47/2013.

## Author details

Jakub Bukala<sup>1\*</sup>, Krzysztof Damaziak<sup>1</sup>, Krzysztof Kroszczynski<sup>1</sup>, Jerzy Malachowski<sup>1</sup>, Tomasz Szafranski<sup>1</sup>, Michal Tomaszewski<sup>1</sup>, Hamid R. Karimi<sup>2</sup>, Krzysztof Jozwik<sup>3</sup>, Maciej Karczewski<sup>3</sup> and Krzysztof Sobczak<sup>3</sup>

\*Address all correspondence to: [jakub.bukala@wat.edu.pl](mailto:jakub.bukala@wat.edu.pl)

1 Military University of Technology, Warsaw, Poland

2 University of Agder, Grimstad, Norway

3 Lodz University of Technology, Lodz, Poland

## References

- [1] IEC 61400-2: Wind turbines—part 2: small wind turbines. International Electrotechnical Commission; 2013. doi: ISBN 978-2-8322-1284-4
- [2] Gsänger S, Pitteloud J. Small Wind World Report 2014. WWEA; 2014
- [3] Aresti L, Tutar M, Chen Y, Calay RK. Computational study of a small scale vertical axis wind turbine (VAWT): comparative performance of various turbulence models. *Wind and Structures*. 2013;17(6):647–670.
- [4] Grijalva S, Umer Tariq M. Prosumer-based smart grid architecture enables a flat, sustainable electricity industry. *IEEE*; 2011. doi: ISBN 978-1-61284-220-2
- [5] Woofenden I, Sargillo M. Is wind electricity right for you. *Home Power*. 2011;143:52–61.
- [6] Gasch R, Twele J. Wind power plants: fundamentals, design, construction and operation, 2nd edition. Springer; Heidelberg 2012. doi: ISBN 978-3-642-22937-4.
- [7] Burton T, Jenkins N, Sharpe D, Bossanyi E. Wind energy handbook. 2nd edition. John Wiley and Sons Ltd.; Chichester 2011.
- [8] Bedon G, Castelli MR, Benini E. Optimization of a Darrieus vertical-axis wind. *Renewable Energy*. 2013;59:184–192.
- [9] Technical Application Papers: Wind Power Plants. No 13 ed. ABB SACE e ABB S.p.A. L.V.; 2011.
- [10] Ohya Y, Karasudani T. A shrouded wind turbine generating high output power. *Energies*. 2012;3(4):634–649.
- [11] Olasek K, Karczewski M, Lipian M, Wiklak P, Jozwik K. Wind tunnel experimental investigations of a diffuser augmented wind turbine model. *International Journal of Numerical Methods for Heat and Fluid Flow*. Forthcoming. DOI (10.1108/HFF-06-2015-0246).
- [12] Manwell JF, McGowan JG, Rogers AL. Wind energy explained: theory, design and application. Chichester: John Wiley & Sons; 2003.
- [13] Kwansu K, Changhee L, Yong-Oon O, Ilhan K, Neungsoo Y, Insu P. Time-domain dynamic simulation of a wind turbine including yaw motion for power prediction. *International Journal of Precision Engineering and Manufacturing*. 2014;15(10):2199–2203.
- [14] International Electrotechnical Commission. IEC 61400-2: Wind turbines—part 2: small wind turbines. 3.0 edition. IEC, Geneva 2013. doi: ISBN 978-2-8322-1284-4

- [15] Bukala J, Damaziak K, Karimi HR, Malachowski J. Upwind vs downwind small wind turbine comparison—numerical analysis and economical evaluation. *Journal of Wind Engineering & Industrial Aerodynamics*. Forthcoming.
- [16] Hau E, editor. *Wind turbines fundamentals, technologies, applications, economics*. 2nd edition. Springer; Heidelberg 2006. doi: ISBN 3-540-24240-6
- [17] Iowa State University. Iowa State Engineers Study the Benefits of Adding a Second, Smaller Rotor to Wind Turbines [Internet]. March 6, 2015. Available from: <http://www.news.iastate.edu/news/2015/03/06/dualrotorturbines> [Accessed: February 10, 2016]
- [18] T. Letcher, The Ohio State University, Columbus, OH. Small Scale Wind Turbines Optimized for Low Wind Speeds [Internet]. Available from: [http://kb.osu.edu/dspace/bitstream/handle/1811/45531/hayes\\_proceedings\\_paper.pdf?sequence=1](http://kb.osu.edu/dspace/bitstream/handle/1811/45531/hayes_proceedings_paper.pdf?sequence=1) [Accessed: February 10, 2016]
- [19] Kozlov VV, Bychkov NM. Wind Turbine with Magnus Effect [Internet]. [Updated: 2011]. Available from: <http://www.itam.nsc.ru/en/section/292/> [Accessed: February 10, 2016]
- [20] Goudarzi N, Zhu WD. A review on the development of wind turbine generators across the world. *International Journal of Dynamics and Control*. 2013;1(2):192–202.
- [21] Rolland S, Auzane B. The potential of small and medium wind energy in developing countries. Position Paper: Alliance for Rural Electrification; 2012.
- [22] Bukala J, Damaziak K, Kroszczyński K, Krzeszowiec M, Malachowski J. Investigation of parameters influencing the efficiency of small wind turbines. *Journal of Wind Engineering and Industrial Aerodynamics*. 2015;146:29–38.
- [23] Bukala J, Damaziak K, Karimi HR, Kroszczyński K, Krzeszowiec M, Malachowski J. Modern small wind turbine design solutions comparison in terms of estimated cost to energy output ratio. *Renewable Energy*. 2015;83:1166–1173.
- [24] Al-Yahyai S, Charabi Y, Gastli A. Review of the use of Numerical Weather Prediction (NWP) Models for wind energy assessment. *Renewable and Sustainable Energy*. 2010;14(9):3192–3198.
- [25] Elliott D, Infield D. An assessment of the impact of reduced averaging time on small wind turbine power curves, energy capture predictions and turbulence intensity measurements. *Wind Energy*. 2012;2(17):337–342.
- [26] Small Wind Certification Council. Evance Summary Report. SWCC. 2013; pp. 10–27.

