

Smart Bin: Internet-of-Things Garbage Monitoring System

Mustafa M.R¹, and Ku Azir K.N.F^{1*}

¹Universiti Malaysia Perlis, ENAC Research Cluster, 02600, Arau, Perlis, Malaysia

Abstract. This work introduces the design and development of smart green environment of garbage monitoring system by measuring the garbage level in real time and to alert the municipality where never the bin is full based on the types of garbage. The proposed system consisted the ultrasonic sensors which measure the garbage level, an ARM microcontroller which controls system operation whereas everything will be connected to ThingSpeak. This work demonstrates a system that allows the waste management to monitor based on the level of the garbage depth inside the dustbin. The system shows the status of different four types of garbage; domestic waste, paper, glass and plastic through LCD and ThingSpeak in a real time to store the data for future use and analysis, such as prediction of peak level of garbage bin fullness. It is expected that this system can create greener environment by monitoring and controlling the collection of garbage smartly through Internet-of-Things.

1 Introduction

From 1950 until 2017, Malaysia's population has rapidly increase 74% which makeup into Malaysia current population which is 31, 164, 177 where 77% of the population is staying at urban. According to United Nations Population Fund (see www.unfpa.org), by 2030 five billion of people will be lived in urban areas, therefore, there is no surprise where Malaysian produce an average of 30,000 tons of waste every day and only 5% percent of it is recycled. According to Ministry of Urban Wellbeing, Housing and Local Government shows that these waste are resulting in tremendous land and air pollution for the environment, health problems for communities and bottlenecks to the economic growth. Taken together, the problem of poor waste management in Malaysia is one of the nation's biggest issues to date.

Waste can be divided into two categories, liquid or solid waste, both can be hazardous. Both of these waste can be group into organic, re-usable and recyclable waste. Mainly, liquid waste came from a point source or non-point source discharges such as wash water from homes, liquids used from cleaning in industries and waste detergents. Meanwhile, solid waste is any garbage, refuse or rubbish that make from home. These include old car tires, old newspapers, broken furniture and even food waste.

Generally, in Malaysia waste management is monitor by the state council. Locally, in Perlis the waste management managed by Idaman company which was given the responsibility by the state council to collect the waste. The domestic wastes are collected twice a week while the recycled wastes are collected once a week.

* Corresponding author: fazira@unimap.edu.my

Though, the waste collection is consistent however the current collection does not allow the local municipal to know the status of the garbage bin either full or empty. This practice of garbage collection become irregular and not relevant, once the increasing of state's population. Whilst, it does not have a systematic schedule to collect every type of garbage, the overloaded garbage will attract animals and insects. So, it will create unhygienic condition for surrounding environment and creates bad smell which can lead in spreading some deadly disease and human illness. Current garbage collection is inefficiencies, time waste and required a huge amount of human energy. This is because the garbage collectors need to check whether the garbage is full or not according to the fix schedule. The objectives of the project are to design a prototype of Internet-of-Thing (IoT) garbage monitoring system and alert the garbage collectors the fullness of the bin by identify the level of garbage based on the depth of the bin.

2 Garbage Monitoring System

Waste management is the activities and actions required to manage waste from its origin to its final disposal. This incorporates in addition to other things, collection, transport, treatment and disposal of waste together with monitoring and regulation. It also includes the legal and regulatory framework that relates to waste management encompassing guidance on recycling.

The term normally relates to all kinds of waste, whether generated during the extraction of raw materials, the processing of raw materials into intermediate and final products, the consumption of final products, or

other human activities, including municipal, agricultural, and social. Waste management is intended to reduce unfriendly effects of waste on health, the environment or aesthetics. Waste management practices are not uniform among countries developed and developing nations, regions urban, rural area, sectors residential and industrial. Thus, many researchers and industry are trying their best to create a resolution of finding smarter way to manage waste pollution.

Prakash and Prabu [1] have design IoT Base Waste Management for Smart City for solving the trash overflow which create unhygienic condition and bad smell around the surrounding. This project has two part that are transmitter section and receiver. The 8051 microcontroller, RF Transmitter and sensors in the transmitter section that attached to the dustbin. The receiver section using RF Receiver, Intel Galileo, and Web Browser is used. This system can detect waste level in dustbin and avoid the overflow of dustbin. Meanwhile, Tey Ja Sin and et al., [2] design a sustainability waste management. This concept was design based on the interview to six industry practitioner in both private and government sector in Malaysia. S.S.Navghane et al., [3] use the dustbin that interfaced with microcontroller based system having IR wireless systems along with central system showing current status of garbage, on mobile web browser with html page by Wi-Fi. Hence the status will be updated on to the html page.

Smart Garbage System (SGS) [4] is proposed to reduce the amount of food waste. The system exchange information with each other using wireless mesh networks, and a router and server collect and analyse the information for service provisioning and been operated as pilot project in Gangnam district. The results showed that the average amount of food waste could be reduced by 33%. "Smart Bin" by [5] was designed to manage the waste collection system based on smart city. The network of sensors enabled smart bins connected through the cellular network generates a large amount of data, which is further analysed and visualized at real time to gain insights about the status of waste around the city. Meanwhile, Catania and Ventura [6] proposed smart waste collection by using smart-M3 platform to improve and optimize the handling of solid urban waste by introduce 'green points' for encouraging citizens to recycle. On the other hand, Medvedev et., al [7] IoT components such as RFIDs, sensors, cameras and actuators for efficient waste collection by proposed Decision Support System (DSS) for efficient waste collection in Smart Cities. The system handles ineffective waste collection by incorporates a model for data sharing between truck drivers on real time and dynamic route optimization.

3 Methodology

Fig 1 shows the application of this project that demonstrates a system based on Internet-of-Thing (IoT)

that allows the waste management to monitor based on the level of the garbage depth inside the dustbin. The system let users being alert the level of garbage on four types of garbage; domestic waste, paper, glass and plastic.



Fig. 1. Implementation of proposed waste management system

Meanwhile, Fig 2 shows the proposed system through a block diagram. The proposed system is using ultrasonic sensor as input and placed at the maximum level of the garbage bin. The system consists the ultrasonic sensor which measure the garbage level and an ARM microcontroller which controls system operation whereas everything will be connected to ThingSpeak. At the same time, the level of garbage also will display on LCD to allow user to know the level of garbage in the dustbin without open it. The four ultrasonic sensors connect to ARM microcontroller to detect the level of garbage of each bin based on the depth of the bin. At the same, these four ultrasonic sensors connect to ESP8266 wifi module to make sure the data transfer and display on ThingSpeak. The LCD are interfaces with ARM microcontroller will display the percentage of the garbage for each bins. In this work, the system will try to monitor the depth of the garbage based on garbage type. The domestic waste does not wait the bin to be 100% full as the longer it will be in the bin; the longer the domestic waste will be rotten and create unpleasant environment.

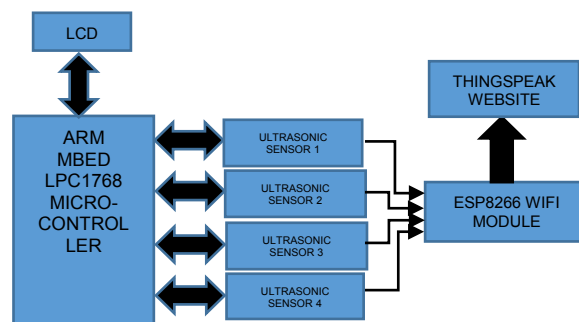

Fig. 2. Block diagram of the proposed system

Fig 3 shows the circuit diagram and each component connect each other. Here, four ultrasonic sensors are connected to ARM microcontroller and ESP8266 wifi module using logic level converter. The function of logic level converter is to reduce the voltage from ultrasonic sensor 5V to 3.3V. This is because every PIN in ESP8266 wifi module can accept 3.3V only. If the wifi module accept more than 3.3V it will make the wifi module burn. In this system, the ultrasonic sensor

need at least 5V to generate the data and display the data on LCD. To make connect ultrasonic sensor to wifi module, its need logic level converter to reduce the voltage.

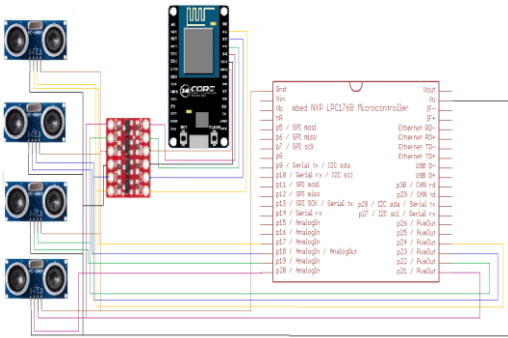

Fig. 3. Circuit Diagram

These four sensors then connected to ESP8266, a low-cost Wi-Fi chip with full TCP/IP stack which give any microcontroller access own network Wi-Fi. It requires a minimal external circuitry and integrates a integrates a 32-bit Tensilica MCU, standard digital peripheral interfaces, antenna switches, RF balun, power amplifier, low noise receive amplifier, filters and power management modules all in one small package. The, mbed NXP LPC1769 is used as the microcontroller as the controller of the system. The date than been collected then send to ThinkSpeak to analyse and visualise uploaded data.

4 Result and Discussion

Fig 4 shows a complete circuit of IoT garbage monitoring system. This system is using ARM microcontroller and ARM application board that attach with the garbage bins to show the real application. This circuit are made from several components which comprises of ARM board, ultrasonic sensor, ESP8266 wifi module, LCD that interface with ARM microcontroller, rechargeable battery, breadboard and some wires as connection.

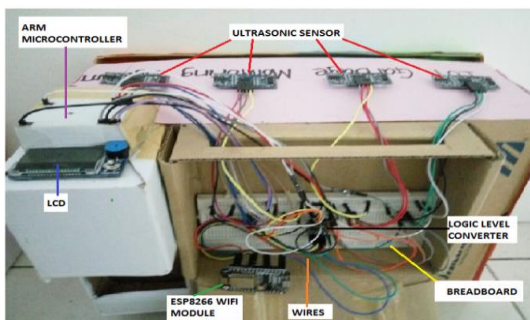

Fig. 4. Complete circuit of IoT garbage monitoring system

The system is evaluated by testing the emptiness and fullness of the garbage bin. Fig 5 (a) shows that the garbage bin is empty thus level of garbage is empty. Data will then display the percentage of the fullness of the bin on LCD that attach at the bin to alert the users percentage of the fullness of the bin.



Fig 5(a)

Fig 5(b)

Fig 5(a) show emptiness of the garbage bin and the level of garbage as shown on LCD in Fig 5(b).

At the same time, data from sensor will send to ThingSpeak via ESP8266 wifi module. The ThingSpeak will shown the data in the real time as shown in Fig 6. The data on the ThingSpeak show the zero value because no garbage in the bin. So, the waste management can monitor based on the level of garbage depth inside the dustbin in ThingSpeak.

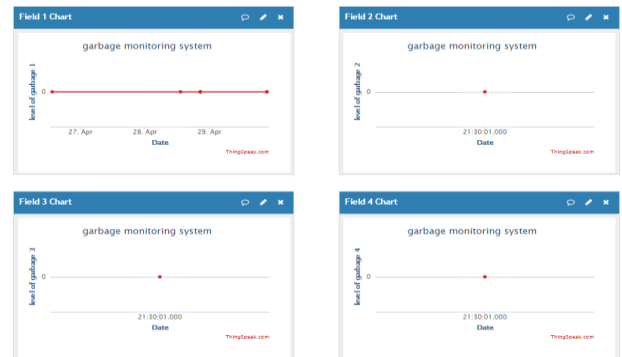

Fig. 6. The data on ThingSpeak for each bin

Fig 7(a) shows the dustbins are full with garbage. The sensor at the bin will detect the level of garbage and will convert it to the percent. The sensor will connect to microcontroller that control system operation. Moreover, data for each bin will display on LCD (Fig 7(b)) that attach at the bin to alert the user how many percent of the garbage in the bins.

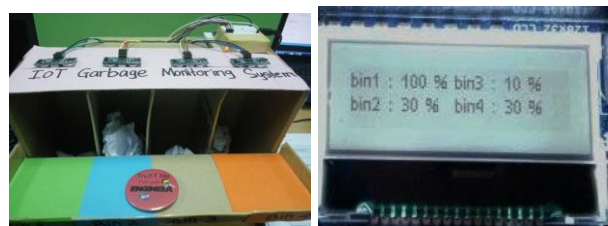

Fig 7(a)

Fig 7(b)

Fig 7(a) show the garbage bin fill in with garbage and the level of garbage as shown on LCD in Fig 7(b).

The data on the ThingSpeak will shows the percentage for each bins to make sure the waste management can monitor it as shown in Fig 8. If the bin is full, the waste management can inform to collector to collect the garbage. So, collector can do their duties without any problem.

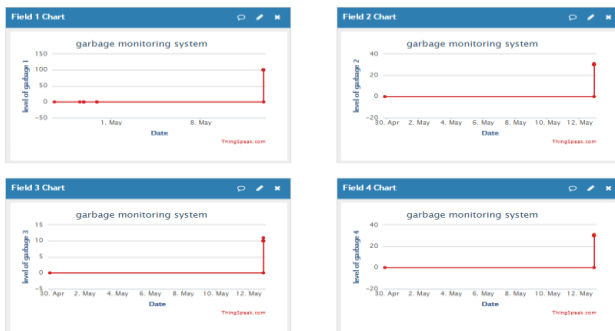

Fig. 8. The data on ThingSpeak once the bin been full with garbage

5 Conclusions

A practical system for monitor the level of garbage is being presented in this paper. This project implementing real time waste management system by using sensors to check the level of garbage in the dustbin. In this system, the information of the dustbin can have accessed from anywhere and anytime. This system will help inform the status of each dustbins in real time. So, waste management can send the garbage collector to pick up the garbage when the dustbin is full. The range of ultrasonic sensor can detect distance is between 2cm until 400cm. This sensor will compare the depth of the dustbin to show the level of garbage in the bin. This sensor will collect the data and sent to microcontroller to display on LCD. At the same time, this sensor will send data to ThingSpeak via ESP8266 wifi module. The data in ThingSpeak will show the data in real time. Therefore, waste management can be monitor.

However, if there is a limited coverage or availability of network, the wifi module will not be working thus will disturb the whole system. A proposed future development of the communication hardware need to be done in the future. Additionally, the development of the system can improve by designing a system that can identify different type of garbage by using image recognition in avoiding mistakenly put the garbage at the wrong bin.

By implementing this proposed system, it will reduce cost, man power and indirectly reducing traffic in that place.

References

[1] Parkash and V. Prabu, "IOT based waste management for smart city," *International Journal Research Computer and Communciation Engineering*, vol. 4, no. 2, 2016.

[2] A. Omran, A. Mahmood, and H. a Aziz, "Current practice of solid waste management in Malaysia and its disposal," *Environmental Engineering Management Journal*, vol. 6, no. 4, pp. 295–300, 2007.

[3] S. S. Navghane, M. S. Killedar, and V. M. Rohokale, "IoT Based Smart Garbage and Waste Collection Bin," *Internatonal Journal of Advanced Research in Electronics and Communication Engineering*, vol. 5, no. 5, pp. 1576–1578, 2016.

[4] I. Hong, S. Park, B. Lee, J. Lee, D. Jeong, and S. Park, "IoT-based smart garbage system for efficient food waste management.," *Scientific World Journal*, vol. 2014, p. 646953, Aug. 2014.

[5] N. Sharma, N. Singha, and T. Dutta, "Smart Bin Implementation for Smart Cities," *International Journal. Science Engineering. Research.*, vol. 6, no. 9, pp. 787–791, 2015.

[6] V. Catania and D. Ventura, "An approach for monitoring and smart planning of urban solid waste management using smart-M3 platform," in *Proceedings of 15th Conference of Open Innovations Association FRUCT*, 2014, pp. 24–31.

[7] A. Medvedev, P. Fedchenkov, A. Zaslavsky, T. Anagnostopoulos, and S. Khoruzhnikov, "Waste management as an IoT-enabled service in smart cities," in *Lecture Notes in Computer Science (including subseries Lecture Notes in Artificial Intelligence and Lecture Notes in Bioinformatics)*, 2015, vol. 9247, pp. 104–115.