

Smart Grid Distribution Management System (SGDMS) for Optimised Electricity Bills

Weixian Li, Chonghao Ng, Thillainathan Logenthiran, Van-Tung Phan, Wai Lok Woo

School of Electrical and Electronic Engineering, Newcastle University, Singapore Campus, Singapore

Email: w.li17@newcastle.ac.uk, c.h.ng@newcastle.ac.uk, t.logenthiran@ncl.ac.uk, vantung.phan@ncl.ac.uk,

lok.woo@newcastle.ac.uk

How to cite this paper: Li, W.X., Ng, C.H., Logenthiran, T., Phan, V.-T. and Woo, W.L. (2018) Smart Grid Distribution Management System (SGDMS) for Optimised Electricity Bills. *Journal of Power and Energy Engineering*, 6, 49-62.

<https://doi.org/10.4236/jpee.2018.68003>

Received: June 30, 2018

Accepted: August 17, 2018

Published: August 20, 2018

Copyright © 2018 by authors and Scientific Research Publishing Inc.

This work is licensed under the Creative Commons Attribution-NonCommercial International License (CC BY-NC 4.0).

<http://creativecommons.org/licenses/by-nc/4.0/>



Open Access

Abstract

This paper presents the use of proposed Smart Grid Distribution Management System (SGDMS) for Singapore contestable and non-contestable consumers. The SGDMS is a distributed management system proposed using Multi-Agent System (MAS) technology. This system can optimise the distribution of renewable energy while minimizing electricity bills for consumers. The entire system was developed using Java with the extension of JADE which is an IEEE FIPA compliant multi-agent system platform. This decentralised platform allows agents to interact and communicate using energy sources from different sectors and control them intelligently to minimise the cost of electricity for the consumers. Simulation studies were carried out on the proposed system to show its potential for providing solutions through intelligent distribution techniques and how it influences the cost of electricity.

Keywords

Smart Grid, Multi-Agent System, Electricity Bill

1. Introduction

Power grid system is one of the main factors which control the distribution of the electricity to various grids. Tradition power grid is usually dispatchable and relatively inexpensive, however, it will cause significant pollution to the environment. As such, renewable energy has been extensively researched due to the generation of clean power sources. However, the generation of power cannot be accurately predicted. Hence, smart grid system is more favourable compared to traditional power grid [1].

In order to achieve a low carbon energy environment, power grids and renewable energy integration developments are currently carried out. However,

the increasing research on such technology would incur a high cost which requires the support of the government [2] [3] [4] [5].

The world renewable energy has been contributing 19% to the current electricity usage. Hydroelectric energy had been producing 16%, thus making wind and PV energy production modest, but it means that many initiatives can improve these renewable energies [6] [7].

Renewable energy systems (RES) are not able to replace existing electrical grids as it has been established and used for ages due to its reliability. Although RES technology is not able to cope with the demand of electricity consumption these days, integrating it with the existing power grid has shown that it is able to change the system towards certain extent [8] [9].

RES involves certain criteria to be practical. The criteria are reliability, efficiency, development of algorithms for advanced control, and monitoring. Therefore, availability of equipment or tools would be crucial for the research of such technology [10]. The use of RES was encouraged by various countries to decarbonise the traditional power generators. This resulted in increasing use of wind, tidal, and solar to produce distributed power for the grid with immense pace.

Ng, C. H., *et al.* [11] proposed an intelligent distributed smart grid network using reconfiguration to perform self healing on a mesh transmission network. This proposed method uses a set of rules and search techniques to solve sudden abnormal situations in the grid. However, it did not consider the cost of electricity despite solving anomaly situations.

W. Li., *et al.* [12] proposed an intelligent multi-agent system for power grid communication. This proposed method introduces MAS to enhance the data communication in existing power grid for efficient power distribution. However, except the enhancement of data communication, it did not include any algorithms for optimising the power distributions and reducing electricity cost. Thus, these studies show the need of algorithms to reduce the cost of electricity in the power grid with enhanced communication channel.

The proposed Smart Grid Distribution Management System (SGDMS) allows smart grid to be equipped with better distribution techniques to optimise electricity costs. Additionally, the proposed system includes MAS as its communication channel that increases the reliability and efficiency of data transmission.

The remaining paper is organised as follows: Section 2 shares the information used for the proposed system. Section 3 shows the proposed SGDMS. Section 4 provides simulation results. Finally, the paper is concluded in Section 5.

2. Information on Power Grid in Singapore

Singapore power grid was distributed to 3 main sub-grids which are the industrial, commercial, and residential grids. Transport-related and others grids contain a smaller distribution of electricity. Singapore is exploring the options of

alternative power resources using renewable energy to create a smart nation concept of a green country.

Singapore power grid has one of the most reliable electricity networks in the world. The grid had already deployed advanced Supervisory Control and Data Acquisition (SCADA) systems which were able to read electricity supply data to bring its power grid capabilities even further.

In Singapore, the Energy Market Authority (EMA) was set up to liberalise the electricity markets to promote reliable, secure, and effective electric supply. Energy Market Company (EMC) was established to connect the electricity makers and buyers in order to give alternative from regulated tariffs from SP Services [13]. The wholesale electricity market allows the consumer to purchase electricity from the electricity retailers that fluctuates every half an hour. Currently, in Singapore, a commercial or industrial consumer with an average monthly electricity consumption of 2000 kWh (approximately SGD\$550) is eligible to be contestable while residential consumers are all non-contestable [14].

The electricity prices were separated into contestable and non-contestable due to different pricing in electricity purchase. Contestable consumers are able to purchase from the electricity market using wholesale pricing run by Energy Market Company while non-contestable consumers use the regulated tariff prices from SP Services.

Table 1 data shows the total power harvested from renewable energy in Singapore. **Table 2** shows the data taken from Energy Market Authority of Singapore [15]. **Table 3** shows the data of the total electricity in the period, day, and year. **Table 4** shows the electricity price for a contestable consumer in a 48 period (24 hours) format from Energy Market Company (EMC) for 1st September 2015 [16]. The non-contestable consumer's electricity pricing were 20.35 cents per kWh (with effect from 1 Oct. 15 to 31 Dec. 15) regardless of the time periods [17]. These data collected accommodates different electricity pricing which allows economical research on both non-contestable and contestable electricity sources.

$$P_{\text{day}} = P_{\text{year}}/365 \quad (1)$$

$$P_{\text{period}} = P_{\text{day}}/365 \quad (2)$$

where, P_{year} represents the total power consumption in a year, P_{day} in a day, and P_{period} in a period.

The average power consumption is scaled down to year, day, and period using the formula 1 and 2. Due to different periods having different prices, it can be used to calculate how much the consumers were paying per period.

The mathematic equation for renewable energy in Singapore was defined as follow:

$$P_{\text{SG Wind/year}} = P_{\text{Wind}}/39 \quad (3)$$

$$P_{\text{SG Tidal/year}} = P_{\text{SG Tidal/Period}} * 365 * 24 \quad (4)$$

Table 1. Total renewable energy harvest in Singapore.

Renewable Energy	Power per annum for Singapore (MWh)
Wind	0.26
Tidal	8.76
Solar	4800
Total	4809.02

Table 2. Singapore electricity data.

Year 2014	Contestable (GWh)	Non-Contestable Consumers (GWh)	Total Singapore electricity demand (GWh)
Industrial	18,528.20	1260.30	19,788.50
Commercial	12,163.50	4790.80	16,954.30
Transport	2,284.00	155.4	2439.40
Residential	0	6935.80	6935.80
Others	28.5	256.4	284.90
Overall	33,004.20	13,398.70	46,402.90

Table 3. Different type of power in period, day, and year.

Year 2014	Contestable Consumer			Non-Contestable Consumers		
	Per year (GWh)	Per day (GWh)	Per period (GWh)	Per year (GWh)	Per day (GWh)	Per period (GWh)
Industrial	18,528.20	50.76	1.06	1260.30	3.45	0.07
Commercial	12,163.50	33.32	0.69	4790.80	13.13	0.27
Transport	2284.00	6.26	0.13	155.40	0.43	0.01
Residential	0.00	0.00	0.00	6935.80	19.00	0.40
Others	28.50	0.08	0.00	256.40	0.70	0.01
Overall	33,004.20	90.42	1.88	13,398.70	36.71	0.76

where P_{Wind} represents the total wind power generated for the region for the year, $P_{\text{SG Wind/year}}$ represents the wind power generated for a year in Singapore. $P_{\text{SG Tidal/Period}}$ represents the tidal power generated for a period in Singapore, $P_{\text{SG Tidal/year}}$ represents the tidal power generated for a year in Singapore.

In Singapore, the government agencies JTC Corp and the Housing Board are looking into the use of wind turbines. Small and medium-sized enterprises (SMEs) like CygnusPower and Daily Life Renewable Energy (DLRE) are exploring the usage of wind turbines to have better efficiency. Daily Life Renewable Energy (DLRE) had already built a 10 MW commercial wind farm in Sri Lanka to serve 39 countries in the Asia-Pacific region [18]. Thus the power distribution divided equally using formula 3.

There had been a study that Singapore environment can extract 250 MW peak with a tidal barrage [19]. Thus, a team from Nanyang Technological University

Table 4. Wholesale pricing for 48 periods.

Time	Period	WEP (\$/MWh)	Time	Period	WEP (\$/MWh)
00:00-00:30	1	77.78	12:00-12:30	25	64.45
00:30-01:00	2	73.95	12:30-13:00	26	66.39
01:00-01:30	3	67.14	13:00-13:30	27	71.31
01:30-02:00	4	68.26	13:30-14:00	28	77.6
02:00-02:30	5	66.54	14:00-14:30	29	77.73
02:30-03:00	6	73.85	14:30-15:00	30	85.31
03:00-03:30	7	69.11	15:00-15:30	31	85.24
03:30-04:00	8	67.44	15:30-16:00	32	73.11
04:00-04:30	9	66.06	16:00-16:30	33	67.09
04:30-05:00	10	60.81	16:30-17:00	34	66.28
05:00-05:30	11	55.66	17:00-17:30	35	64.35
05:30-06:00	12	67.75	17:30-18:00	36	60.83
06:00-06:30	13	68.65	18:00-18:30	37	59.85
06:30-07:00	14	66.98	18:30-19:00	38	61.1
07:00-07:30	15	53.95	19:00-19:30	39	65.36
07:30-08:00	16	56.69	19:30-20:00	40	66.49
08:00-08:30	17	59.87	20:00-20:30	41	66.91
08:30-09:00	18	61.41	20:30-21:00	42	61.16
09:00-09:30	19	61.12	21:00-21:30	43	63.52
09:30-10:00	20	64.94	21:30-22:00	44	61.19
10:00-10:30	21	66.55	22:00-22:30	45	58.09
10:30-11:00	22	66.71	22:30-23:00	46	56.34
11:00-11:30	23	66.69	23:00-23:30	47	54.3
11:30-12:00	24	64.59	23:30-00:00	48	53.01

(NTU) designed and built 2 turbines which will extract up to a thousand watts of energy per hour combined. This test project shows the Singapore government support of tidal energy usage [20]. By using formula 4, the Tidal energy for a year in Singapore can be calculated.

Singapore total generations of electricity by PV systems (Solar energy) were estimated to be 4.8 GWh electric energy per annum [21]. Singapore Housing and Development Board (HDB) are currently installing PV systems on residential building rooftops to increase the electricity generation by renewable energy [22]. This information allows a realistic calculated amount of renewable energy produced for the overall power grid in Singapore.

3. Proposed Smart Grid Distribution Management System

3.1. Proposed Algorithm

Figure 1 shows a general flowchart of the algorithm in regard to the price and electricity distribution.

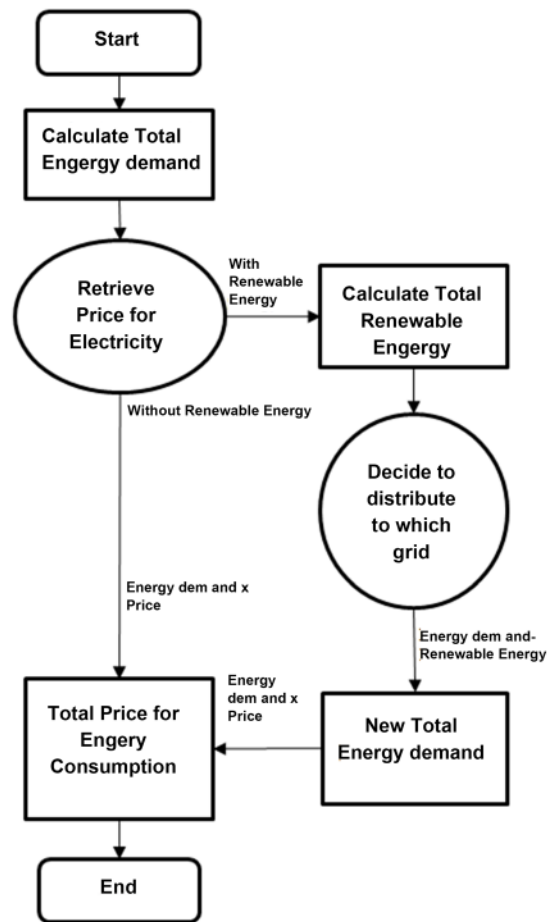

Figure 1. Flowchart for the proposed algorithm.

The mathematical formulas of the cost are defined as follows:

$$M_{\text{cont/yr}} = \left(\sum_{i=1}^{48} P_{\text{cont/period}} * PP_{\text{cont}(i)} \right) * 365 \quad (5)$$

$$M_{\text{non-cont/yr}} = P_{\text{non-cont/year}} * PP_{\text{non-cont}} \quad (6)$$

$$M_{\text{Total/yr}} = M_{\text{cont/year}} + M_{\text{non-cont/year}} \quad (7)$$

where $PP_{\text{cont}(i)}$ represents the price in different period for contestable, $PP_{\text{non-cont}}$ for non-contestable. $M_{\text{cont/yr}}$ represents the total amount of electricity cost in a year for contestable, $M_{\text{non-cont/yr}}$ for non-contestable, and $M_{\text{Total/yr}}$ for the total amount of electricity cost. $P_{\text{non-cont/year}}$ represents the total power for non-contestable in a year, $P_{\text{cont/period}}$ for contestable in a period.

The equations calculate the consumer cost dependent on how the electricity is being distributed in the grid. These equations are widely used in Singapore to calculate the electricity cost for consumers.

3.2. Proposed RES Connections

Figure 2 shows the overall grid connections with RES using Power World Simulator Software [23]. **Figure 3** shows the grid connection with power

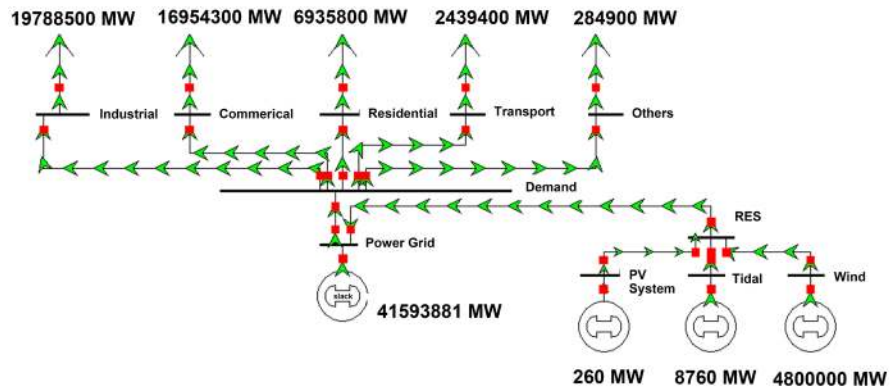

Figure 2. Illustration of overall grid connections.

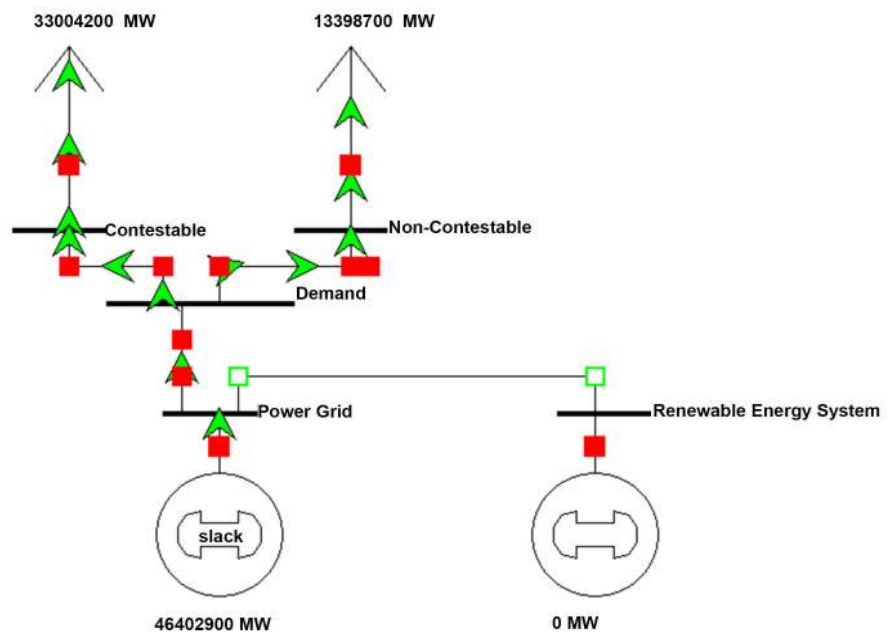

Figure 3. Illustration of PG without RES in PWS.

consumption if no renewable energy is connected. Figure 4 shows the grid connection with power consumption if renewable energy is connected and evenly distributed. Figure 5 shows the grid connection with power consumption if renewable energy is connected and distributed only to contestable. Figure 6 shows the grid connection with power consumption if renewable energy is connected and distributed only to non-contestable.

For this research, Figure 3 will be the first case study, Figure 4 will be the second case study, Figure 5 will be the third, and lastly Figure 6. These case studies will be used to determine the economic impact of the electricity prices in Singapore.

3.3 Proposed Multi-Agent System

Figure 7 depicts the overall picture of the multi-agent system. Smart Grid Distribution Management System (SGDMS) was categorised into two parts

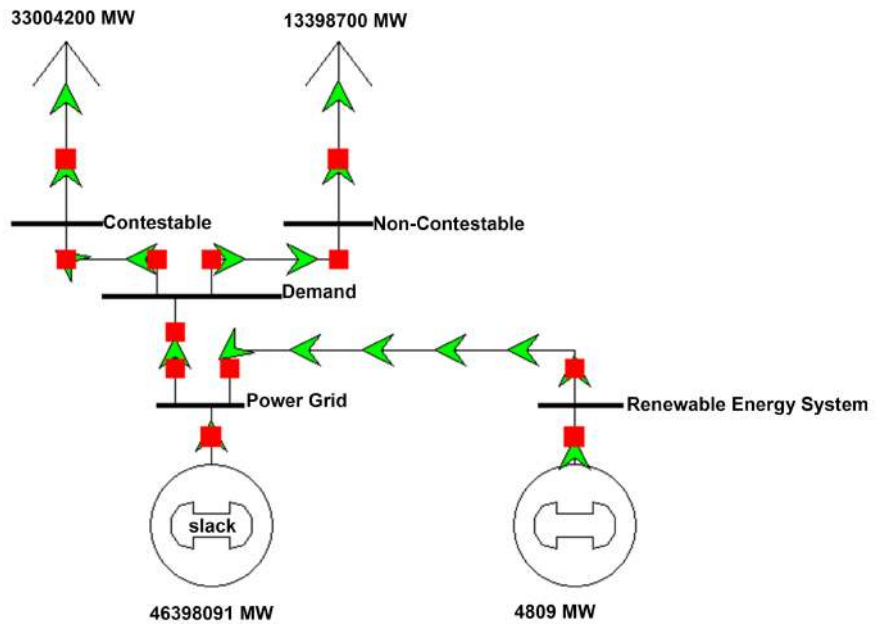

Figure 4. Illustration of PG with RES evenly distributed in PWS.

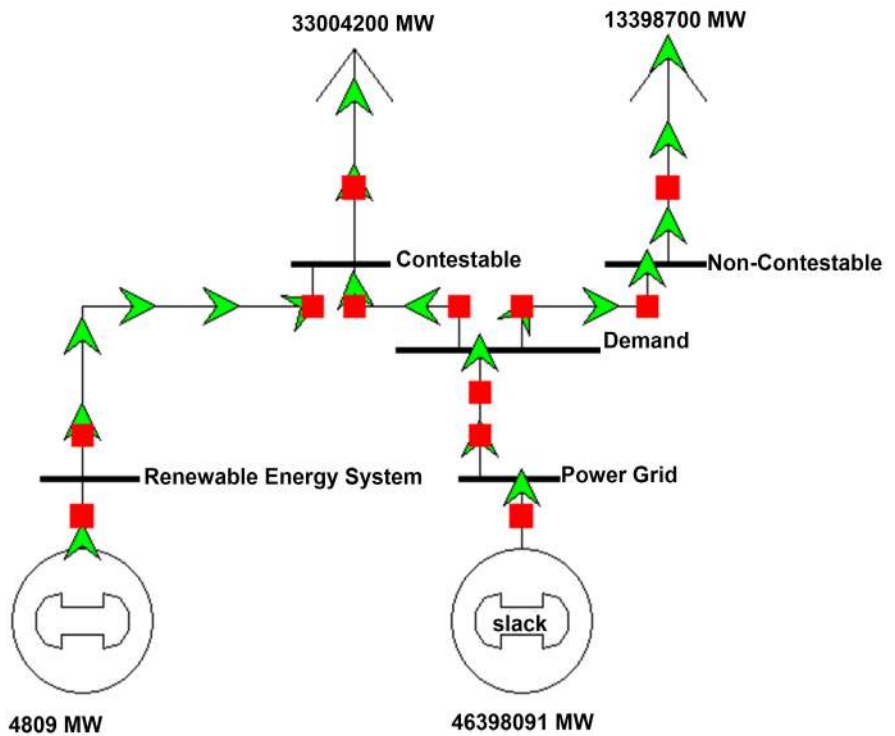

Figure 5. Illustration of PG with RES distribution to contestable in PWS.

which are the Renewable Energy System (RES) and Grid System (GS). RES was then further categorised into three parts which are the PhotoVoltaics (PV) system, Tidal Energy, and Wind Energy. GS was then further categorised into three parts which are the Industrial Grid (IG), Commercial Grid (CG), and Residential Grid (RG).

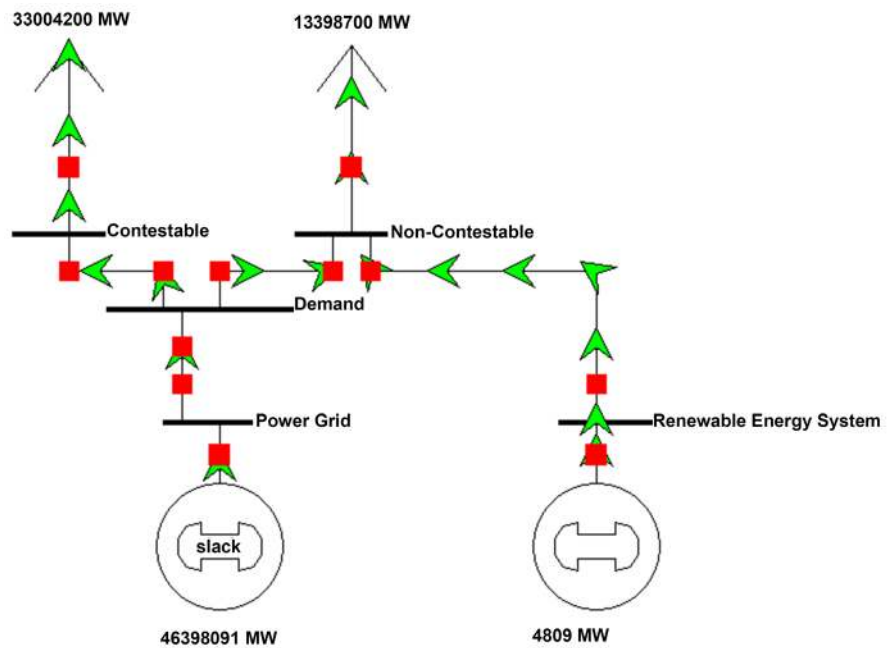

Figure 6. Illustration of PG with RES distribution to non-contestable in PWS.

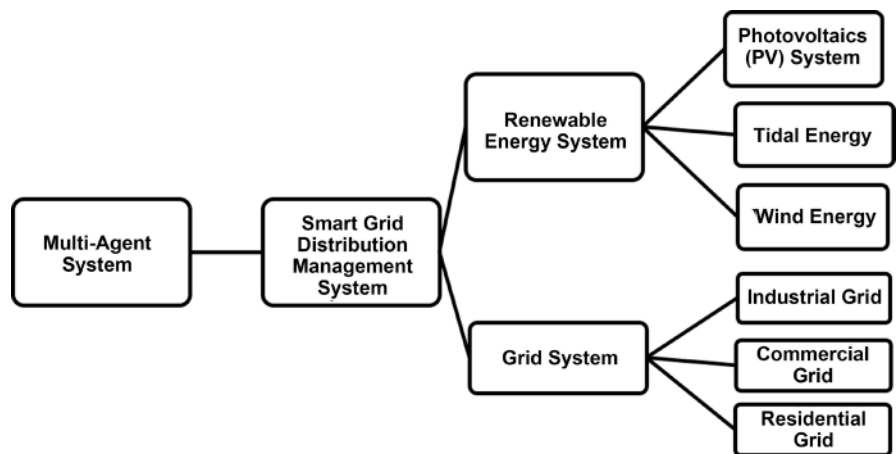

Figure 7. MAS architecture.

The functionality of the RES collects and calculates the data that is available to the SGDMS. GS calculates the amount of electricity that is needed for them. SGDMS will then decide how much power will be distributed to which grid. The messages set are “REQUEST”, “SUBSCRIBE”, “CONFIRM” “, “INFORM” and “CFP”. Each message sent would provide different kinds of information when it is required during the process of algorithm calculations.

4. Simulation Studies and Results

Simulation studies were carried out on the following types of the distribution system which are given in Table 5.

Table 6 represents the final simulation results for each individual power distribution system. It shows a significant difference of up to SGD\$978634.84

Table 5. Representatives of different power distribution system.

Representative	Description
No RES	Power Grid with no RES supply
RES	Power Grid with evenly distributed RES supply
RES1	Power Grid with RES supply distributed to contestable only
RES2	Power Grid with RES supply distributed to non-contestable only

Table 6. Overall results of electricity distribution to different sectors.

Description	No RES	RES	RES1	RES2
Amount of RES power distribution (MWh)				
Contestable	0	2404.51	4809.02	0
Non-Contestable	0	2404.51	0	4809.02
Total Power after RES power distribution (GWh)				
Contestable	33,004.20	33,001.80	32,999.39	33,004.20
Non-Contestable	13,398.70	13,396.30	13,398.70	13,393.89
Average electricity usage (MWh)				
Contestable for 1 period	1883.80	1883.66	1883.53	1883.80
Average electricity price (SGD\$)				
Contestable for 1 day	5,951,889.27	5,951,455.64	5,951,022.021	5,951,889.27
Contestable for 1 year	2,172,439,582	2,172,281,310	2,172,123,038	2,172,439,582
Non-Contestable for 1 year	2,726,635,450	2,726,146,133	2,726,635,450	2,725,656,815
Cost (SGD\$)				
Total for 1 year	4,899,075,032	4,898,427,442	4,898,758,488	4,898,096,397
Savings compared to no RES	0	647,589.66	316,544.49	978,634.84

savings by using the integrated power grid when comparing RES with the traditional power grid.

These results were understood by the amount of money saved when more renewable energy was distributed to the contestable or non-contestable electricity source with the same total electricity consumption. The simulation result shows when more power was distributed to the non-contestable electricity demand, the overall electricity pricing would be cheaper compared to the contestable electricity demand.

The results shown in **Figure 8** use Java with the extension of Jade to simulate the overall results and communications of the grids. **Figure 9** and **Figure 10** shows the result of price per period and the total price of the power grid with or without renewable energy.

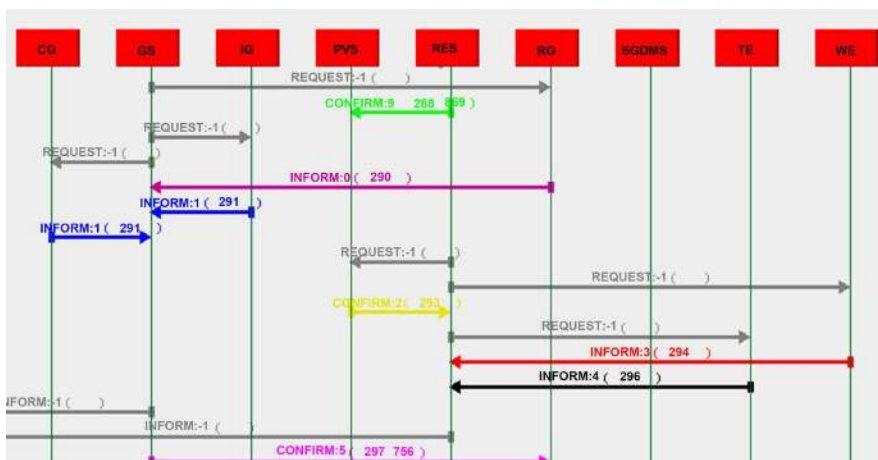

Figure 8. Simulation of MAS communication using JADE.

```

-----
EMC Price for contestable in half an hour=$58.09
Electricity Price for contestable in half an hour= $109430.02157534247
TotalC=$563605.17191781
-----
Period=45
-----
EMC Price for contestable in half an hour=$56.34
Electricity Price for contestable in half an hour= $106133.3691780822
TotalC=$5749738.541095892
-----
Period=46
-----
EMC Price for contestable in half an hour=$54.3
Electricity Price for contestable in half an hour= $102290.41438356164
TotalC=$5852028.955479453
-----
Period=47
-----
EMC Price for contestable in half an hour=$53.01
Electricity Price for contestable in half an hour= $99860.31061643835
TotalC=$5951889.26609892
-----
Power for contestable in half an hour=1883.8013698630136
TotalC=$2.1724395821250005E9
TotalNC=2.72663545E9
TotalPrice for a year=4.899075032125E9
    
```

Figure 9. Simulation of prices for period and year without RES.

These simulations show the effects of economic impacts on the distribution of renewable energy to different sectors.

5. Conclusions

In this paper, it was shown how the use of renewable energy sources makes differences in Singapore power grid. The proposed algorithm optimises the electricity cost of consumers while maximizing the use of renewable energy sources. These simulation studies show that the proposed Smart Grid Distribution Management System (SGDMS) achieves the maximum use of

```

Power for contestable in half an hour=1883.8013698630136
-----
TotalC=$2.1724395821250005E9
TotalNC=2.72663545E9
TotalPrice for a year=$4.899075032125E9
-----
RES power=4809.01641025641
Power for contestable in half an hour=1883.6641262439991
-----
TotalC=$2.1722813098808503E9
TotalNC=2.7261461325802565E9
TotalPrice for a year=$4.898427442461107E9
-----
RES power=4809.01641025641
Power for contestable in half an hour=1883.526882624985
-----
TotalC=$2.1721230376366997E9
TotalNC=2.7263545E9
TotalPrice for a year=$4.89887584876367E9
-----
RES power=4809.01641025641
Power for contestable in half an hour=1883.8013698630136
-----
TotalC=$2.1724395821250005E9
TotalNC=$2.725656815160513E9
TotalPrice for a year=$4.898096397285513E9
-----

```

Figure 10. Simulation of prices for period and year results.

power distribution, minimises the cost of electricity bills and lowers greenhouse effects by the existing power grid.

In the view of the smart grid, this research demonstrates various types of power grid distribution and the impact on the prices based on the current electricity market. These lead to a smart nation concept which would be beneficial to the future of Singapore.

Enhancements of the SGDMS would require an increase in reliability and further improvements for optimization in order to get better efficiency of the grid. With the help of increased renewable energy sources, overloading of generators will be greatly reduced. Ultimately, this approach will step towards a more environmentally friendly and cost-effective grid system for Singapore.

Conflicts of Interest

The authors declare no conflicts of interest regarding the publication of this paper.

References

- [1] Li, W., Logenthiran, T., Woo, W., Phan, V. and Srinivasan, D. (2016) Implementation of Demand Side Management of a Smart Home Using Multi-Agent System. *IEEE World Congress on Computational Intelligence*, Vancouver, BC, 24-29 July 2016, 1-8.
- [2] McArthur, S.D., Davidson, E.M., Catterson, V.M., Dimeas, A.L., Hatziargyriou,

- N.D., Ponci, F. and Funabashi, T. (2007) Multi-Agent Systems for Power Engineering Applications Part I: Concepts, Approaches, and Technical Challenges. *IEEE Transactions on Power Systems*, **22**, 1743-1752.
- [3] McArthur, S.D., Davidson, E.M., Catterson, V.M., Dimeas, A.L., Hatziargyriou, N.D., Ponci, F. and Funabashi, T. (2007) Multi-Agent Systems for Power Engineering Applications Part II: Technologies, Standards, and Tools for Building Multi-Agent Systems. *IEEE Transactions on Power Systems*, **22**, 1753-1759.
- [4] Zhang, D., Li, S., Sun, M. and Neill, Z.O. (2016) An Optimal and Learning-Based Demand Response and Home Energy Management System. *IEEE Transactions on Smart Grid*, **7**, 1790-1801. <https://doi.org/10.1109/TSG.2016.2552169>
- [5] Li, W., Logenthiran, T. and Woo, W. (2015) Intelligent Multi-Agent System for Smart Home Energy Management. *IEEE Innovative Smart Grid Technologies-Asia (ISGT ASIA)*, Bangkok, 3-6 November 2015, 1-6.
- [6] Li, W., Logenthiran, T., Phan, V.-T. and Woo, W.L. (2017) Housing Development Building Management System (HDBMS) for Optimized Electricity Bills. *Transactions on Environment and Electrical Engineering*, **2**, 64-71. <https://doi.org/10.22149/tee.v2i2.113>
- [7] Li, W., Logenthiran, T., Phan, V.-T. and Woo, W.L. (2017) Intelligent Housing Development Building Management System (HDBMS) for Optimized Electricity Bills. *IEEE International Conference on Environment and Electrical Engineering, IEEE Industrial and Commercial Power Systems Europe (EEEIC/I & CPS Europe)*, Milan, 6-9 June 2017, 1-6.
- [8] Chao, H.-L., Tsai, C.-C., Hsiung, P.-A., Chou, I., et al. (2014) Smart Grid as a Service: A Discussion on Design Issues. *The Scientific World Journal*, **2014**, Article ID: 535308.
- [9] Corno, F. and Razzak, F. (2012) Intelligent Energy Optimization for User Intelligible Goals in Smart Home Environments. *IEEE Transactions on Smart Grid*, **3**, 2128-2135. <https://doi.org/10.1109/TSG.2012.2214407>
- [10] Wang, C., Zhou, Y., Jiao, B., Wang, Y., Liu, W. and Wang, D. (2015) Robust Optimization for Load Scheduling of a Smart Home with Photovoltaic System. *Energy Conversion and Management*, **102**, 247-257. <https://doi.org/10.1016/j.enconman.2015.01.053>
- [11] Ng, C., Logenthiran, T. and Woo, W. (2015) Intelligent Distributed Smart Grid Network Reconfiguration. *Innovative Smart Grid Technologies-Asia (ISGT ASIA)*, Bangkok, 3-6 November 2015, 1-6.
- [12] Li, W., Logenthiran, T., Phan, V.-T. and Woo, W.L. (2016) Intelligent Multi-Agent System for Power Grid Communication. *IEEE Region 10 Conference (TENCON)*, Singapore, 22-25 November 2016, 3386-3389.
- [13] Authority, E.M. (2015) Energy Consumption. https://www.ema.gov.sg/cmsmedia/Publications_and_Statistics/Publications/ses/2016/energy-consumption/index.html
- [14] Market, O.E. (2018) Singapore's Electricity Market. <https://www.openelectricitymarket.sg/about/market-overview.html>
- [15] Authority, E.M. (2015) Singapore Energy Statistics. https://www.ema.gov.sg/cmsmedia/Publications_and_Statistics/Publications/SES%202015%20Chapters/Publication_Singapore_Energy_Statistics_2015.pdf
- [16] Company, E.M. (2015) Price information. <https://www.emcsg.com/marketdata/priceinformation#priceDataView>

- [17] S. P. Ltd. (2014) Tari_s.
<http://www.singaporepower.com.sg/irj/servlet/prt/portal/prtroot>
- [18] Cheam, J. (2011) The Straits Times: Singapore Rides on Asia's Wind Market.
<https://www.nccs.gov.sg/news/straits-times-singapore-rides-asias-wind-market>
- [19] Srikanth, N. (2014) Barriers to Ocean Energy Technology Adoption and Role of Policies & Institutional System to Promote in Asia.
<http://www.icoe2014canada.org/wp-content/uploads/2014/11/3-Srikanth-Halifax-presentation-v10.pdf>
- [20] Ee, D. (2011) Singapore's First Tidal Energy Generator Launched off Sentosa.
<https://www.straitstimes.com/singapore/singapores-first-tidal-energy-generator-launched-off-sentosa>
- [21] J. L., *et al.* (2011) Solar Energy Technology Primer: A Summary.
- [22] Tanoto, B. (2017) Hdb Calls "Largest Tender" to Install Solar Panels across Government Agencies.
<https://www.channelnewsasia.com/news/singapore/hdb-calls-largest-tender-to-install-solar-panels-across-9365000>
- [23] P. Corporation. The Visual Approach to Electric Power Systems.
<https://www.powerworld.com/>