

 Open access • Proceedings Article • DOI:10.1109/ISIE.2017.8001563

## **SmartFingerBraille: A tactile sensing and actuation based communication glove for deafblind people** — [Source link](#)

Oliver Ozioko, William Taube, Marion Hersh, Ravinder Dahiya

**Institutions:** University of Glasgow

**Published on:** 01 Jun 2017 - International Symposium on Industrial Electronics

**Topics:** Braille and Tactile sensor

Related papers:

- [Wearable Assistive Tactile Communication Interface Based on Integrated Touch Sensors and Actuators](#)
- [Remote tactile sensing glove-based system](#)
- [Braille reader equipped with tactile sensing mechanism](#)
- [MEMS based Braille system](#)
- [Wearable tactile sensor system for reading braille](#)

Share this paper:    

View more about this paper here: <https://typeset.io/papers/smartfingerbraille-a-tactile-sensing-and-actuation-based-575dtk8j2z>



Ozioko, O., Taube, W., Hersh, M. and Dahiya, R. (2017) SmartFingerBraille: A Tactile Sensing and Actuation Based Communication Glove for Deafblind People. In: 2017 IEEE 26th International Symposium on Industrial Electronics, Edinburgh, UK, 19-21 Jun 2017, pp. 2014-2018. ISBN 9781509014125.

There may be differences between this version and the published version. You are advised to consult the publisher's version if you wish to cite from it.

<http://eprints.gla.ac.uk/149763/>

Deposited on: 16 October 2017

Enlighten – Research publications by members of the University of Glasgow  
<http://eprints.gla.ac.uk>

# SmartFingerBraille: A Tactile Sensing and Actuation based Communication Glove for Deafblind People

Oliver Ozioko<sup>vw</sup>, William Taube<sup>v</sup>, Marion Hersh<sup>u</sup>, Ravinder Dahiya<sup>vw\*</sup>

<sup>v</sup>Bendable Electronics and Sensing Technologies group, School of Engineering, University of Glasgow, UK

<sup>u</sup>Biomedical Engineering Division, School of Engineering, University of Glasgow, UK

\*Correspondence to Ravinder.Dahiya@glasgow.ac.uk

**Abstract**—This paper presents a smart tactile sensing and actuation-based finger-glove to be used by visual and hearing impaired people for communication and learning. It is based on the concept of finger Braille and supports both face-to-face and distant communication. The device comprises of a smart finger-glove worn on both hands in the ring, middle and index finger and communicates with mobile devices using Bluetooth technology. Six tactile sensors and actuators each were used and a pair embedded in the glove in the ring, middle, and index fingers of both hands to represent the six dots of the Braille code. The user wears the smart finger-glove and taps the correct finger combination corresponding to the Braille code on any surface to compose and send messages to mobile devices or other gloves. Messages can equally be received with the glove from a mobile device in the form of vibrations on the fingers corresponding to the Braille codes. The facile and low-cost nature of the device will make it attractive to Braille users and makes learning Braille an entertainment activity and could spur the interest of sighted people also to learn Braille.

**Keywords**—*finger Braille; deafblind; communication; smart glove; tactile sensing; actuator*

## I. INTRODUCTION

Deafblindness is a dual sensory impairment resulting from combination of significant vision and hearing impairments which leads to significant barriers in communication, access to information, mobility and participation in the society [1]. Deafblind people are people who have this sort of impairment. They use several methods of communication which depends on the extent and history of their impairment as well as country [2]. These methods can be divided into tactile and non-tactile (e.g. speech, sign language) approaches. The focus here is on tactile methods which include, deafblind manual alphabets, Braille etc. This disability often poses a great challenge for this important group of people in terms of communication and usage of modern information and communication technology.

Braille is an effective method of reading and writing for the blind community, but research shows that Braille literacy is low among blind people [3]. A Braille cell is made up of six dots, and combination of raised dots is used to represent letters, numbers and special characters. By touching the Braille cell, the user checks which of the dots are raised up and through it interpret the characters. Although originally intended for the purpose of information being documented on paper, braille can now be used as a digital aid for conversation, with some smartphones offering braille displays, and computer braille keyboards allowing access to instant messaging software, Skype or chat rooms [3]. Braille is largely used by the blind

community and by a small percentage of the deafblind people [4]

Several different types of tactile communication devices based on Braille have been developed, including devices to support finger-Braille and devices on mobile or smart phones. Finger Braille is a method deafblind communication in which the ring, middle and index fingers of both left and right hands are used to represent the six dots of the Braille cell. Body Braille involves putting some form of tactile stimulation on six different locations of the body of the deafblind person (usually at the back) and a combination of these six locations corresponding to Braille code are stimulated to carry out communication [5]. A tele-support system was developed for deafblind people using body-Braille and mobile phone [5]. The mobile phone was used to support the deafblind person remotely and the response is interpreted in the form of body vibration which is based on Braille. Though the technology was able to make remote support possible, its limitations include the high cost of video transmission, and too many wires on the user's body. In [6] they introduced "B-brll" which is very similar to the tele-support system but in this work the concept of using two micro-vibrators instead of six were presented. This only helped to reduce the number of vibrators that are placed on the body of the deafblind person, but not other limitations. In continuation of their research on body-Braille systems they implemented the body Braille based on two micro-vibrators and added more features that enables the deafblind person to determine a nearby communication partner and its two-way communication is based on infrared wireless technology [7]. Despite the improvement in this device, the infrared technology used is a line-of-sight method of communication.

Furthermore, there are other existing devices that are also based on Braille, but are not wearable. A prototype was developed by M. Chun *et al.* [8] which is particularly usable by sighted people who can read Mandarin phonetics. Though the device costs as low as NT\$4,000 (about £105), it does not support remote communication. Fernando *et al.* developed a communication device for deafblind people using ARM-based computer (Raspberry Pi) as the main processing unit [9]. The device enables deafblind people to communicate and carry out public speaking using USB keyboard and voice output. Deafblind people can receive messages using a Braille display. The device uses Braille display which is expensive, does not support remote communication and requires individuals to take turn to use the keyboard. Yasuhiro, M. *et al.* developed a finger braille teaching interface based on Japanese Braille and used to teach clauses [10].

The proposed device “SmartFingerBraille” in this paper is based on finger Braille and can be easily used both for communication as well as for learning the Braille and thereby, an effective means to address the Braille literacy problem. Different types of tactile sensing technologies have been applied for similar touch-sensing applications including capacitive [11], resistive [12] etc. Resistive tactile sensor was adopted in this work.

Tactile sensation is very important for human beings and has been used by deafblind people as a means of communication. Designs involving tactile stimulation of the human skin require paying attention to the threshold of human tactile perception. In [13], it was reported that human detectable indent corresponding to different areas of the palm is around 10 $\mu$ m to 50 $\mu$ m, and in [14], the vibration range of 20 to 1000Hz are perceivable with maximum sensitivity around 250Hz. Also the pressure exerted by a tactile device should be above 60mN/cm<sup>2</sup> in order to adequately stimulate the finger mechanoreceptor [15]. It was equally reported in [16] that 90% of mechanoreceptors are able to detect forces as low as 85mN applied on an area of 1mm<sup>2</sup>. A number of actuation technologies have been proposed for tactile stimulation of the fingers including, Electroactive polymers, piezoelectric, and electromagnetic etc. [14]. In this work, vibrotactile stimulation of the deafblind person’s finger was achieved using a coin-type eccentric rotation mass (ERM) vibration motor which has a rated vibration frequency of about 203Hz.

This paper is structured as follows: section II presents the description of the entire modules of the system, section III gives details of how the glove was fabricated. In section IV, the testing of the device and its results were presented. Finally the paper ends with a conclusion and some references.

## II. DESCRIPTION OF THE SYSTEM

SmartFingerBraille is based on the concept of finger Braille. But in this case there is no need of physical contact, and deafblind people can independently use this to communicate with sighted and hearing people as well as other deafblind people. It is made up of a smart finger-glove that communicates with a mobile app via Bluetooth technology. The concept of the smart glove is as shown in Fig. 1 comprising mainly of six tactile sensors and six actuators which represent the six dots of the Braille. The tactile sensors are positioned at the tip of index, middle and ring fingers of both left and right hands, while the haptic actuators are positioned at the back of these fingers correspondingly. The tactile sensors are used to compose and send messages to mobile devices by tapping the tip of the finger on any surface in order to compose messages based on Braille codes. Messages are received using the haptic actuators in the form of vibrations.

This means that deafblind people can either use this glove to communicate with a nearby or remote mobile phone user as well as a nearby or distant smart-glove user. The glove-to-glove communication is via the mobile phone internet which enables distant deafblind-to-deafblind chat as shown in Fig. 2.

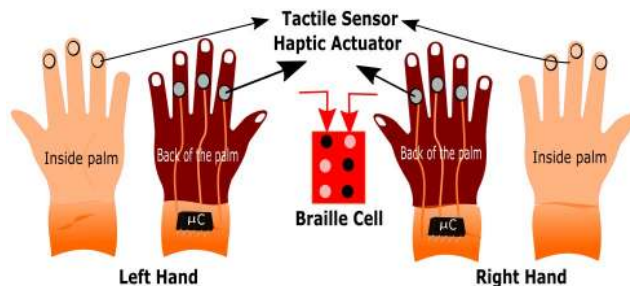

Fig. 1. The concept of the smart finger-glove

### A. Input Unit

The input unit receives user input from the glove wearer and comprises of six polymeric Force Sensing Resistors (FSR) placed at the tip of the ring, middle and index fingers of both left and right hands to represent the Braille codes. The FSR used is a polymeric thick film device whose resistance decreases with increase in applied force. It was chosen due to its low-cost and availability. The performance of the FSR was measured using different loads and Fig. 3 shows its response. It is clear from Fig. 3 that its sensing range falls within “gentle touch” which corresponds to a pressure of 5 - 90 kPa [11]. A digital filter was implemented in the program to compensate for any drift or noise in the measurement. A threshold was set during the design in order to effectively determine when a finger is pressed.

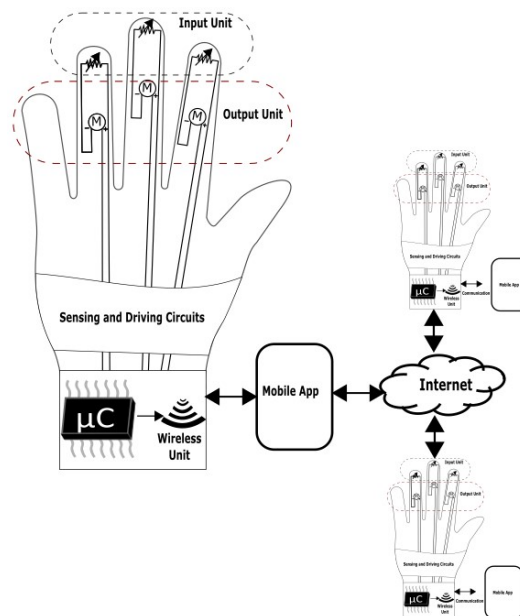

Fig. 2. Modular description of the proposed system

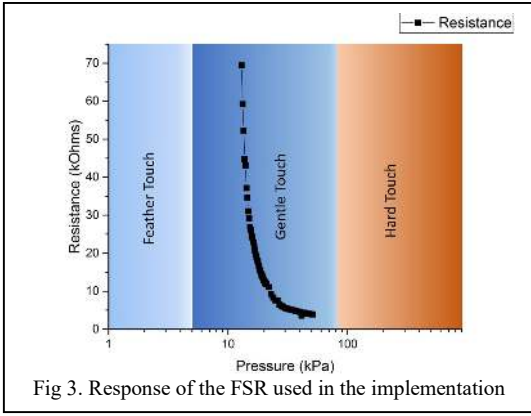

Fig 3. Response of the FSR used in the implementation

### B. The Output Unit

The output unit is primarily made of six 10mm Eccentric Rotation Mass (ERM) vibration motors (310-113.002 from Precision Microdrives) with rated current and voltage of 63mA and 3V. It has a rated vibration speed of 12,200rpm which is about 203Hz. In order to choose a suitable actuator capable of giving a suitable tactile stimulation to the finger of the deafblind user, some requirements specifications were formed and then parameters of different actuators compared based on these specifications. These specifications include: small size (about 10mm), vibration frequency of about 200Hz which is within the human-vibration detectable range of 20-1000Hz as cited in introduction, low power consumption, low cost, 3V DC input signal, simple drive mechanism, durable quality. Four different categories of actuators were considered, these are: Linear Resonant Actuator (LRA), piezoelectric and Electroactive polymer (EAP) actuators as shown in Table I. Parameters considered include: Range of vibration frequency, type of drive signal, haptic performance, durability, cost and availability. Table I shows that the ERM meets most of the aforementioned specification and hence is a good choice for this application.

### C. Control and Wireless Unit

The control unit controls all the different modules in the smart glove and was built around an Atmega32U4 microcontroller. The control unit includes also the wireless unit and the power supply unit. The power supply was designed to give 3V to the vibration motors as per motor specification and 5V to the rest of the circuit. Fig.4 shows a simplified functional circuit diagram of the smart glove with interfacing passive components.

The wireless unit was realised using the HC-05 Bluetooth module because it is capable of being configured both as master and slave using ATtention (AT) commands, unlike the HC-06. Bluetooth wireless technology was chosen because it suits the following wireless communication requirements which were created for the implementation of the smart glove. These are: low power consumption, short range (10-100m), low data rate, small bandwidth, and ease of use with mobile phone, and cost. Table II shows a comparison of some wireless communication protocols [17]. Bluetooth technology

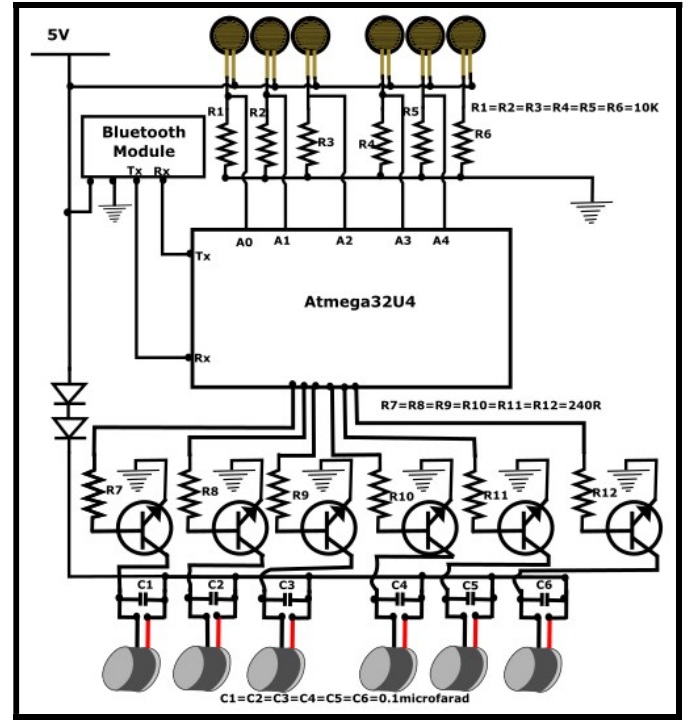

Fig.4. Simplified functional circuit diagram of the smart glove

was selected with a major focus on range, cost and ease of use with mobile phone.

### III. FABRICATION OF SMART FINGER GLOVE

The glove was fabricated using neoprene with the off-the-shelf touch sensors and actuators embedded in it. The input and output units were fabricated in two different segments. The input unit which has the FSR embedded was fabricated like a dome shape structure and sits on the finger like a finger cap.

TABLE I. COMPARISON OF SOME COMMON ACTUATORS

Parameter	Actuator type				Choice for Smart Finger Braille
	ERM	LRA	Piezo-electric	Electro-active polymer	
Form factor	3mm-20mm	2mm-10mm	<3mm	<3mm	All
Vibration Freq. Range	47-280Hz	Fixed (typically 150 – 200Hz)	About 150-300Hz usable	95-125Hz	All
Type of Drive Signal	DC	AC	DC	DC	ERM
Haptic performance	Good	Better	Very good	Very good	ALL
Durability	Durable	Very durable	Very durable	Excellent	All
Cost and availability	Very cheap & available	Cheap and available	Expensive	Expensive	ERM

TABLE II. COMPARISON OF SOME WIRELESS COMMUNICATION PROTOCOLS [17].

Parameter	Wireless Communication Protocols			Choice for SmartFinger Braille
	Bluetooth	Ultra-wide band (UWB)	ZigBee	
Frequency Band	2.4 GHz	3.1-10.6 GHz	868/915 MHz; 2.4 GHz	All
Max Signal Rate	1 Mb/s	110 Mb/s	250 Kb/s	Bluetooth, Zigbee
Nominal Range (m)	10-100	10	10 - 100	All
Nominal Transmitter Power	0 - 10 dBm	-41.3 dBm/MHz	(-25) - 0 dBm	ZigBee, Bluetooth
Channel Bandwidth	1 MHz	500 MHz - 7.5 GHz	0.3/0.6 MHz; 2 MHz	Bluetooth, ZigBee
Ease of Use with Mobile phone and PC	Very Easy to Configure	Not easy	Not easy	Bluetooth
Cost	Very cheap	Cheap	Very cheap	Bluetooth, ZigBee

The output unit which houses the vibration motor was made in ring shape and also worn like a ring. The front and back view of a single finger of the glove is shown in Fig. 5a. The vibration motors were bonded to these neoprene using iron-on fabric and the fabric sewn. The rectangular-shaped neoprene was then folded in the shape of a ring and sewn. The sewn neoprene was then turned inside-out to properly secure and position the embedded vibration motors. The input unit was fabricated by first cutting six different pieces of neoprene material into dome shapes. The input and output units of the glove were attached together using Velcro and all wires embedded in a stretchy cotton jersey fabric.

#### IV. DEVICE TESTING AND RESULTS

Two main testing stages are intended for this device: (1) Laboratory testing and (2) end-user testing. Only first stage testing was carried out which involved no real deafblind person. Testing with real deafblind people is part of the future work. Three of the researchers were used as subjects for the testing. The testing involved verifying the correct transmission of the 26 letters of the English alphabet, short words, numbers and special characters. During the test, the glove was worn on the hand by one subject while the second subject holds the mobile phone and the third records the response and waits for a turn. The Braille codes and the corresponding letters were visually presented to the subjects since they have no prior knowledge of Braille. The user wearing the glove taps the corresponding fingers on a desk to send messages to the

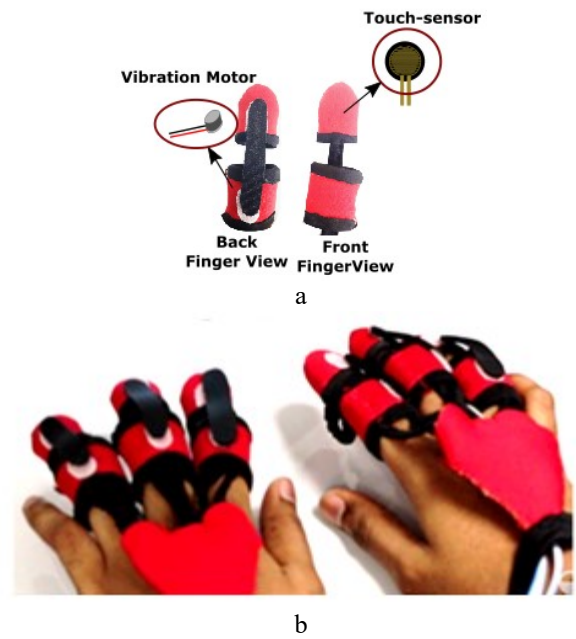

Fig.5. (a) A single-finger glove (b) SmartFingerBraille glove worn on the hand.

mobile app. Each of the three subjects wore the glove and equally held the mobile phone in turn so as to have a feel of both sides and be able to give the necessary feedback. The Braille code of all the 26 letters of the English alphabets were first typed and sent one by one and then followed by numbers and special characters including space. Next was the typing and sending of different words e.g. “hi”, “touch of genius” etc. Both short and long phrases/words were able to be sent and received. Fig. 5b shows the smart finger-glove worn in the hand during testing. Fig. 6 shows the implemented smart phone app. Fig. 6a, shows the mobile app during the testing of the communication from mobile phone to the glove. The word “HI” was sent to the glove and the corresponding fingers vibrated to translate the letters received to Braille codes. Fig. 6b shows the result of sending the Braille code for the letters “abcd” from the glove by gently tapping the corresponding

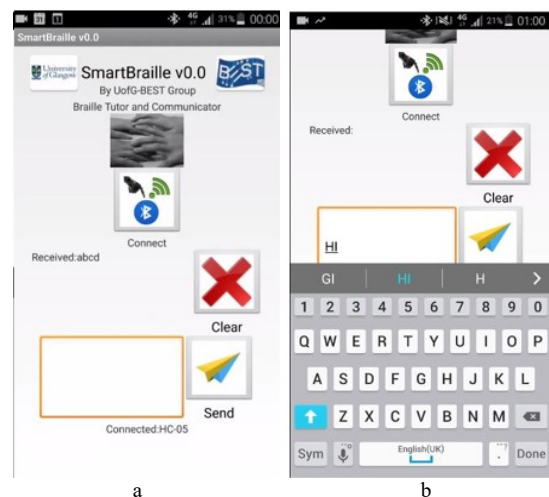

Fig. 6. Smartphone App (a) Receiving message and (b) Sending message using SmartFingerBraille

fingers on a desk. All sent messages were properly displayed on the mobile app.

## V. CONCLUSION AND FUTURE WORK

A smart tactile communication glove for deafblind people has been presented. This facile device was designed for the purpose of allowing deafblind people to communicate independently with mobile device users and hence have an increased access to information and communication technology. The developed smart glove has the potential to enable this important group of people to also learn and play games. Presently the device can only be used for the English alphabets, numbers and popularly used special characters.

Future work will be done for the interpretation of accented and other additional letters e.g. Cyrillic and Greek alphabets, and to properly test the device with actual end-users. There is also plan to add options for spoken input and voice output and ability to communicate with other Bluetooth-based Braille devices. Research is also ongoing towards the fabrication of a more power-effective micro-actuator which will replace the off-the-shelf vibration motors used in this work.

## ACKNOWLEDGMENT

This work was supported in part by Engineering and Physical Sciences Research Council (EPSRC) Fellowship for Growth - Printable Tactile Skin (EP/M002527/1) project. We are also thankful to Glasgow Electronic Systems Design Centre (ESDC) for their support in terms of device design and characterization.

## REFERENCES

- [1] O.Ozioko, and M.A. Hersh. "Development of a portable two-way communication and information device for deafblind people". in 13th AAATE International Conference. 2015. Budapest, Hungary: IOS Press.
- [2] M.A. Hersh, K. Worrall, and M.A. Johnson, eds. "A survey of AT for deafblind people: state of the art and new developments". Assistive Technology: Shaping the future, ed. G.M. Craddock. 2003, IOS Press.
- [3] A.Alfadhe, M.A Khan, and S. C.D. Freitas, "Magnetic tactile sensor for Braille reading". IEEE Sensor Journal, 2016. 16(24): P. 8700-8705.
- [4] M.A.Hersh, and M.A. Johnson, "Information technology, accessibility and deafblind people", in AAATE 2005. 2005: Lille, France.
- [5] O.Satoshi, S.Hasegawa, N.Sssaki, and T.Harakawa, "The introduction of tele-support system for deaf-blind people using body-Braille and a mobile phone", in 5th IEEE Consumer Communication and Networking Conference. 2008: Las Vegas, Nevada. p. 1263-1264.
- [6] O.Satoshi, N.Sssaki, S.Hasegawa and T.Harakawa,., Body-Braille system for disabled people", in ICCHP 2008. 2008, Springer-Verlag Berlin Heidelberg. p. 682-685.
- [7] O.Satoshi, S.Hasegawa, N.Sssaki, T.Harakawa, "Communication system between deaf-blind people and non-deafblind people using body-Braille and infrared communication", in 7th IEEE Consumer Communication and Networking Conference. 2010: Las Vegas, Nevada.
- [8] S.Mu-Chun, et al., "Portable communication aid for deaf-blind people". Computer & Control Engineering Journal, 2001: p. 37-43.
- [9] R.G.Fernando, et al., "My Vox - Device for the communication between people: blind, deaf, deaf-blind, and unimpaired". IEEE Explore, 2014: p. 506-510.
- [10] M.Yasuhiro, et al. "Finger Braille teaching system for people who communicate with deafblind people". in Proceedings of the 2007 IEEE International Conference on Mechatronics and Automation. 2007. Harbin, China.
- [11] W.T.Navaraj, et al. "Upper limb prosthetic control using toe gesture sensors". In: IEEE Sensors Conference, Busan, South Korea, 01-04 Nov 2015, pp. 1-4. ISBN 9781479982035.
- [12] A.Polishchuk, Navaraj, W.T., Heidari, H., Dahiya, R. "Multisensory smart glove for tactile feedback in prosthetic hand". 30<sup>th</sup> Eurosensor Conference. Procedia Engineering. Elsevier. vol. 168 (2016): 1605-1608.
- [13] R.S.Johansson and A.B.Vallbo, "Detection of tactile stimuli. thresholds of afferent units related psychophysical thresholds in the human hand". The Journal of Physiology, 1979. 297: p. 405-422.
- [14] L.Spirkovska, "Summary of tactile user interfaces techniques and systems". 2005, NASA Ames Research Center; Moffett Field, CA, United States: United States
- [15] J.Streque, et al., "New magnetic microactuator design based on PDMS elastomer and MEMS technologies for tactile display". IEEE Transaction on Haptics, 2010. 3(2): p. 88-97.
- [16] R.S., Dahiya, and M. Valle, "Robotic tactile sensing: Technologies and systems". 2013: Springer Dordrecht Heidelberg New York London.
- [17] J.-S.Lee, Y.-W. Su, and C.-C. Shen, "A comparative study of wireless protocols: Bluetooth, UWB, ZigBee, and Wi-Fi", in The 33rd Annual Conference of the IEEE Industrial Electronics Society (IECON). 2007, IEEE: Taipei, Taiwan. p. 46-51.