

SOCIAL ENTREPRENEUR IN ORGANIZATIONAL CULTURE AND ORGANIZATIONAL EFFECTIVENESS IN SUSTAINABILITY OF SEKOLAH PETERNAKAN RAKYAT NGUDI REJEKI KEDIRI

Nurus Sabani^{*1}, Anggraini Sukmawati^{*}, and I Made Sumertajaya^{*}

^{*}Department of Management, Faculty of Economics and Management, IPB University
Jl. Agatis, IPB Dramaga Campus Bogor 16680, Indonesia

Abstract: This study aimed to analyze the influence of social entrepreneurs, organizational culture, and organizational effectiveness for the sustainability of the Sekolah Peternakan Rakyat Ngudi Rejeki (SPR). The study population and sample were all members of the Sekolah Peternakan Rakyat Ngudi Rejeki, amounting to 31 SPR members. Interviews and questionnaires did the data collection, and the data was analyzed with the structural equation model - partial least square (SEM-PLS). The results showed that social entrepreneurs have a positive and significant effect on organizational culture, organizational effectiveness, and indirectly on organizational sustainability; organizational culture has a positive and significant effect on organizational effectiveness. Culture has not significantly or indirectly affected sustainability. Organizational effectiveness has not significant effect on organizational sustainability.

Keywords: organizational culture, organizational effectiveness, organizational sustainability, Social entrepreneur, SPR

Abstrak: Tujuan penelitian ini menganalisis pengaruh social entrepreneur, budaya organisasi dan efektivitas organisasi bagi keberlanjutan Sekolah Peternakan Rakyat Ngudi Rejeki Kediri. Populasi dan sampel penelitian adalah seluruh anggota Sekolah Peternakan Rakyat Ngudi Rejeki yang berjumlah 31 anggota. Metode pengumpulan data menggunakan wawancara dan kuesioner, metode analisis data menggunakan structural equation model- partial least square (SEM-PLS). Hasil penelitian menunjukkan bahwa social entrepreneur berpengaruh positif dan signifikan terhadap budaya organisasi, social entrepreneur berpengaruh positif dan signifikan terhadap efektivitas organisasi, social entrepreneur berpengaruh positif dan signifikan tidak langsung terhadap keberlanjutan organisasi, budaya organisasi berpengaruh positif dan signifikan terhadap efektivitas organisasi, budaya organisasi tidak memiliki dampak positif dan signifikan secara langsung atau tidak langsung terhadap keberlanjutan organisasi. Efektivitas organisasi tidak berpengaruh signifikan terhadap keberlanjutan organisasi.

Kata kunci: Budaya organisasi, efektivitas organisasi, keberlanjutan organisasi, wirausaha sosial, SPR

¹ Corresponding author:
Email: jinurus28@gmail.com

INTRODUCTION

Sustainability was first introduced in the concept of Triple Bottom Line (TBL or 3BL); People, Planet and Profit (Elkinjton, 1998). The concept emphasizes the empowerment of others, both members of the organization, consumers, and society in general that makes economic entities educate people as a major factor in maintaining the organization's sustainability. If organizational members are well educated, it could lead to the workforce producing cost-efficient, quality products. Not only economic entities maintain the sustainability of the required raw materials and energy, but pollution and waste generated by organizations must be environmentally friendly and the impact is very small for the environment. If the organization members, consumers, and the community are empowered and the planet remains sustainable, the benefits will automatically come for the organization. This means that profit is not the main objective, rather the impact of good and responsible organizational performance is.

Environmental and social sustainability are increasingly important concerns to companies, governments, academics, and civil society organizations (Narayanan and Boyce, 2018). An organization can maintain its existence in the future, One of the efforts that need to be done is how the organization can be responsive to all the changes that occur, as well as social entrepreneurship or social entrepreneurship organizations (Umniyyati and Martono, 2017).

In 2013, LPPM IPB made a breakthrough by establishing a Sekolah Peternakan Rakyat (Smallholder Farm School) abbreviated as SPR which is classified as social entrepreneurship. Social entrepreneurship is a new concept that has been applied progressively to overcome social problems (Bernadino et al. 2018). This means that social enterprise is an organization that is devoted to overcoming problems in society by using business methods. The ultimate goal of social entrepreneurship is to create social value and achieve social benefits in the long run (Moss et al. 2013).

In one SPR there is one leader, namely the chair of the DPPT (Dewan Perwakilan Pemilik Ternak, DPPT). Martono (2013) stated that the task and role of a leader is essential in determining the organization members's quality of work and thus the right person is needed to lead the organization. The Chairman of the DPPT is democratically elected by farmers who are considered

to have broader insights compared to other farmers. Members who are elected as Chairman of the DPPT must be prepared to spread a series of actions for the welfare and sovereignty of the SPR members and the impact should benefit the broader community. The Chairman of the DPPT is a social entrepreneur because they lead social businesses and do not work for their personal interests but for the welfare of SPR members and the community (Ghalwash et al. 2017).

Social entrepreneurs start with sensitivity to social problems, skills, background or experience, discourse, demographics, and motives that surround them, eventually generating an idea that others sometimes never thought of. The work done by a social entrepreneur involves other people, and the surrounding community gets an impact from what he does and leads to better change for the environment.

A social entrepreneur's managerial skills are needed to overcome social problems and overcome business challenges that often change, which is possible because they are always innovating and looking for new opportunities for social goals (Ebrashi, 2013). However, not all social entrepreneurs can successfully complete tasks, depending on the ability of specific individuals to match the shape of the organization (Saxena, 2017).

Social entrepreneurs can be called "unreasonable" which is people who deviate because of thinking and working outside in general, because what is done is not for their personal interests but for others' welfare. Social entrepreneur as a leader in social entrepreneurship has a relationship with many factors, one of which is organizational culture. Organizational culture is created by shared experience in solving organizational problems regarding external and internal survival of the organization, but it is the leader who starts the process of culture formation by implementing beliefs, values, and assumptions of action at the outset (Muthiane et al. 2010).

The object of this research is Sekolah Peternakan Rakyat Ngudi Rejeki Kediri (Smallholder Farm School, SPR Ngudi Rejeki Kediri). In 2017 the government of Kediri Regency through the Department of Animal Husbandry and Fisheries collaborated with the Bogor Institute of Agriculture Community Service Research (LPPM IPB) to form the SPR Ngudi Rejeki. The program is supported by IPB livestock experts and livestock academics whose aim is to improve livestock welfare through capacity

building and technological insemination (especially feed and production technology) by providing training to farmers.

The provided training can help farmers be more effective in their short-term and long-term work. Research also shows that organizational training members to acquire individual or managerial skills is one of the processes in increasing organizational effectiveness (Rahman et al. 2013). The need for professional management of human resources (HR) in the company to create a balance between the needs of members with the company's demands and capabilities. Upon establishing the SPR, one of the expected outcomes was the establishment of a collective a small-scale legal business entity for small farmers managed professionally and proportionally.

The problem that occurs in the Smallholder Farm School to date is that when the mentoring or education period is over, the SPR's life will also end. This means that there is no sustainability of the organization in the future, while it is hoped that the SPR can run the organization in an independent and sustainable manner. The researchers' reason conducted a study on SPR Ngudi Rejeki Kediri was because in 2019 the SPR had completed the mentoring program and had been declared passed by the Institute of Research and Community Service (LPPM) of IPB University. Moreover, the organization wheel is run independently by the Chairman of DPPT and the members of SPR. In 2019 SPR Ngudi Rejeki completed a mentoring program spanning 2 years and 6 months and was declared graduated by LPPM IPB. Furthermore, the organization's wheels are run by the Chairman of the DPPT which is expected to be able to shape the culture of the organization with values that bound the SPR members to achieve high organizational effectiveness and the sustainability of the SPR Ngudi Rejeki in the future.

Previous researchers have found that organizational sustainability is influenced by the competence of employees and learning organizations (Muslim et al. 2017). Organizational sustainability can also be attained by maintaining organizational trust, which acts as a catalyst for employee involvement and leaders' role in creating open communication with subordinates (Ilyas et al. 2020). Ikhwan et al. (2018), said that the learning organization is still possible to be implemented in SPR Maju Bersama to maintain the continuity of its business.

There have been limited empirical literature studies that examined the correlation between social entrepreneurs, organizational culture, organizational effectiveness, and sustainability. Therefore, this study attempts to find the correlation among social entrepreneurs, organizational culture, organizational effectiveness, and sustainability.

Organizational culture as organizational values and norms that become habits and beliefs inherent in an organization as the basic foundation of behaving rules that form the same attitudes and behaviors in members of one organization (Nahdluddin and Martukhah, 2015). Organizational culture also supports the formation of a climate in the organization, the larger an organization and the longer it stands, the more climate will be formed in the organization (Tahapary and Martono, 2017).

Organizational effectiveness is the work produced more than the work of the number of individuals and groups (Martono and Wijayanto, 2014). High organizational effectiveness is the ultimate goal of every organization since it involves people's perceptions about how effectively the organization achieves its goals. It can be concluded that the effectiveness of the organization is measured by how much the organization produces higher levels of output than the output of each member of the organization and groups that involve people's perceptions in assessing how effective the organization is (Mehdibeigi et al. 2016).

The literature above became the base of this study. This study aimed at: 1) identifying the impact of the social entrepreneur on the organizational culture, 2) identifying the impact of a social entrepreneur on the organizational effectiveness, 3) identifying the impact of a social entrepreneur on the sustainability, 4) identifying the impact of organizational culture on the organizational effectiveness, 5) identifying the impact of organizational culture on the sustainability, and 6) identifying the impact of organizational effectiveness on the sustainability.

The study focused on the social entrepreneur in organizational culture and organizational effectiveness in the sustainability of SPR Ngudi Rejeki. For social entrepreneur measurement, the study used Satar and Natasha (2019) theory, with four indicators including social passion, innovativeness, pro-activeness, and risk-taking. For the measurement of organizational culture, the study used Cameron and Quinn (2011) theory, with

four indicators including clan culture, adhocracy culture, market culture, and hierarchical culture. The study used the theory Quinn and Rohrbaugh (1983) to measure organizational effectiveness, with four indicators, including the rational objectives model, human relations model, open systems model, and Internal process model. For the measurement of sustainability, the study used the theory Elkington (1998), with three indicators including economic sustainability, social sustainability, and environmental sustainability.

METHODS

School for smallholder community Ngudi Rejeki Kediri is one of the SPRs in Indonesia that has completed their schooling or mentoring period in a period of 2 years 6 months and is among the fastest SPRs compared. The population of samples in this study consisted of every beef and dairy cattle farmers who are also a member of SPR Ngudi Rejeki Kabupaten Kediri, amounting to 31 people. This study uses primary data. The survey was done using a complete census method.

This research uses Structural Equation Modeling - Partial Least Square (SEM-PLS) analysis. Use of SEM PLS processing was done because the research sample is relatively small and SEM PLS can analyze constructs that are formed with reflective indicators and formative indicators (Ghozali, 2014).

To build an SEM model, the minimum number of samples needed is about 5 times the number of research indicators. Therefore, to meet these requirements, a resampling process was conducted with a recovery of size 100. This means that in the resampling process with recovery, there is a chance that one sample may appear more than once. This process is done using Minitab version 16 to get consistent results.

Researchers conducted interviews with the management and members of SPR Ngudi Rejeki using the questionnaire. The rating scale uses the five-point Likert scale ranging from number one to number five with the following explanation: number 5 (strongly agree), number 4 (agree), number 3 (neither agree nor disagree), number 2 (disagree), number 1 (strongly disagree). The assessment is used to determine the differences in agreement from the respondents on the questions asked.

The very fast technological advances not only give rise to modern civilization, but organizations are faced with the threat of future uncertainty. Chairman of the DPPT as a leader who has strategic policies in carrying out the SPR. SPR Ngudi Rejeki visions and missions are interpreted as the general description of the organization. SPR Ngudi Rejeki fortune makes the Chairman of the DPPT the key to running the organization's wheels. Operational framework of this study in Figure 1 and operational definition in Table 1.

The literature on the correlation between social entrepreneurs, organizational culture, organizational effectiveness, and sustainability rarely contains empirical proof. Based on the discussion of various theories and problems above, this study hypotheses can be formulated as:

- H1 Social entrepreneurs have a positive and significant effect on organizational culture.
- H2 Social entrepreneurs have a positive and significant effect on organizational effectiveness.
- H3 Social entrepreneurs have a positive and significant effect on organizational sustainability.
- H4 Organizational culture has a positive and significant effect on organizational effectiveness.
- H5 Organizational culture has a positive and significant effect on organizational sustainability.
- H6 Organizational effectiveness has a positive and significant effect on organizational sustainability.

RESULTS

Evaluation of measurements (Outer Model)

In this research, all outer model evaluations use reflective indicators on all latent variables. This measurement model can be assessed using reliability and validity. To find out if the variable is said to be stable, the variable has to have a composite reliability value greater than 0.6 and has a Cronbach's alpha value greater than 0.7. Assessing the construct's validity can be determined by looking at the AVE value, a good model when each construct value is greater than 0.5. Table 2 can be explained that of the four constructs that have fulfilled the reliable and valid criteria, namely the composite value of composite reliability values above 0.6, Cronbach's alpha above 0.7 and AVE values above 0.5 as recommended (Ghozali, 2014). It can be concluded that the construct of this study has good reliability and validity.

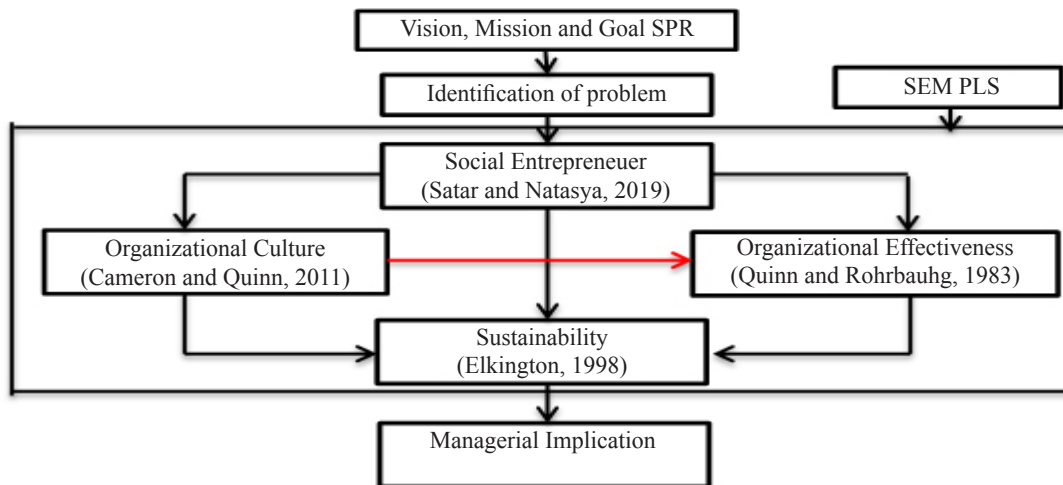

Figure 1. The Research Framework

Table 1. Operational definition

Variabel	Indicator		Definition
Social Entrepreneur	Social Passion	Satar and Natasha (2019)	have an explicit focus on creating social value
	innovativeness	Satar and Natasha (2019)	always trying new ideas through a unique approach with good planning and solving problems in different ways in general
	Pro-activeness	Satar and Natasha (2019)	usually act in anticipation of future problems, needs or changes
	Risk-taking	Satar and Natasha (2019)	like to take bold actions by venturing into the unknown
Organizational Culture	Clan culture	Cameron and Quinn (2011)	creating a sense of togetherness like family in the organization, prioritizing teamwork, involving members, and guiding members to easily participate with customers
	Adhocracy culture	Cameron and Quinn (2011)	prioritizing the creation of new ideas in dealing with changes in needs that will occur in the future
	Market culture	Cameron and Quinn (2011)	focus on the results-oriented organization's external environment
	Hierarchical culture	Cameron and Quinn (2011)	a form of formal organization, controlled, standardized in all work activity processes in the organization
Organizational Effectiveness	Rational objectives model	Quinn and Rohrbaugh (1983)	organizational success in achieving the objectives that have been set together
	Human relations models	Quinn and Rohrbaugh (1983)	the success for the well-being of organizational members
	Open systems model:	Quinn and Rohrbaugh (1983)	the organization's ability to facing the environment to gain resources in future organizational development
	Internal process model	Quinn and Rohrbaugh (1983)	Organizational success in information management, and participation of members in joint decision-making planning and supervision in the implementation of tasks
Sustainability	Economic sustainability	(Elkington 1994)	aims to gain benefit and prosperity for the members of the organization
	Social sustainability	(Elkington 1994)	organizational responsibility to internal and external organizations
	Environmental sustainability	(Elkington 1994)	The organization's ability to maintain nature sustainability by replacing natural resources with eco-friendly technology

Table 2. Assessment of the measurement model

Latent variable	Composite Reliability	Cronbach's Alpha	AVE
Social Entrepreneur	0.919	0.863	0.792
Organizational culture	0.945	0.923	0.812
Organizational Effectiveness	0.954	0.936	0.838
Sustainability	0.907	0.845	0.765

Figure 2 shows that the outer model results that have been reprocessed without an indicator that has an outer loading value below 0.5. In this study, indicators of social entrepreneur variables that have coefficient values below 0.5. Thus the SO4 (risk-taking) reflective indicator is removed. At the same time, the reflective indicators of organizational culture variables, organizational effectiveness, and sustainability all have reliability and validity because these values are above 0.5.

Evaluation of Structural Models (inner model)

Structural models are tested by finding the R-square value, which is a goodness-of-fit test of each endogenous variable's model. Table 3 shows the R-square values of this study's three endogenous variables, namely how much the exogenous variables explain the diversity of endogenous variables. The model of the influence of social entrepreneurs on organizational culture gives an R-square value of 0.645,

Based on Table 4, it can be explained that social entrepreneurship (SE) has a positive and significant effect on organizational culture (OC). This can be seen from the output of the path coefficient of 0.803 with a t-statistic of 18.201 > 1.96. Social entrepreneur has a positive and significant effect on meaning that social entrepreneur variables can explain organizational culture variables by 64.4 percent, while 35.6 percent is explained by other variables outside the research, such as the organization's structure, organization behavior, and leadership style.

The organizational effectiveness variable is formed by the social entrepreneur variable and organizational culture with an R-square value of 0.930. Variable organizational effectiveness can be explained by social entrepreneur variables and organizational culture with a diversity of 93 percent.

Sustainability variables are formed by social entrepreneur variables, organizational culture variables, and organizational effectiveness variables which have an R-square value of 0.344. It can be concluded that sustainability can be explained by social entrepreneur variables, organizational culture, and organizational effectiveness variables for up to 34.4 percent. The remaining of 65.6 percent was affected by other variables not explored in this research.

Organizational effectiveness (OE) directly with a value of 0.291 with a t-statistic of 4.981 > 1.96 and indirectly with of the path coefficient of 0.574 with a t-statistic of 9.969 > 1.96. Social entrepreneurship (SE) has positive and significant indirect effects on sustainability (S). This is indicated by the value of the coefficient of the magnitude of 0.504 and t-statistics of 7.419 > t-table (1.96).

Organizational culture (OC) has a positive and significant effect on organizational effectiveness (OE). With a path coefficient value of 0.715 with a t-statistic of 12.091 > 1.96. Organizational culture (OC) has no significant effect directly or indirectly on the sustainability (S) of the SPR. This is indicated by the path coefficient direct effects of 0.130 with a t-statistic of 0.346 < 1.96 and by the path coefficient indirect effects of 0.331 with a t-statistic of 1.142 < 1.96. While organizational effectiveness (OE) has not significant effect on sustainability (S) with a path coefficient value 0.462 and t-Statistics 1.273 < 1.96.

Research Hypothesis Testing

Testing the hypothesis of this study can be seen from the value of the output bootstrapping on the path coefficient seen in Table 4. To see the positive or negative relationship between constructs seen from the original sample value (O), and the significance of the factors can be seen from t-statistics.

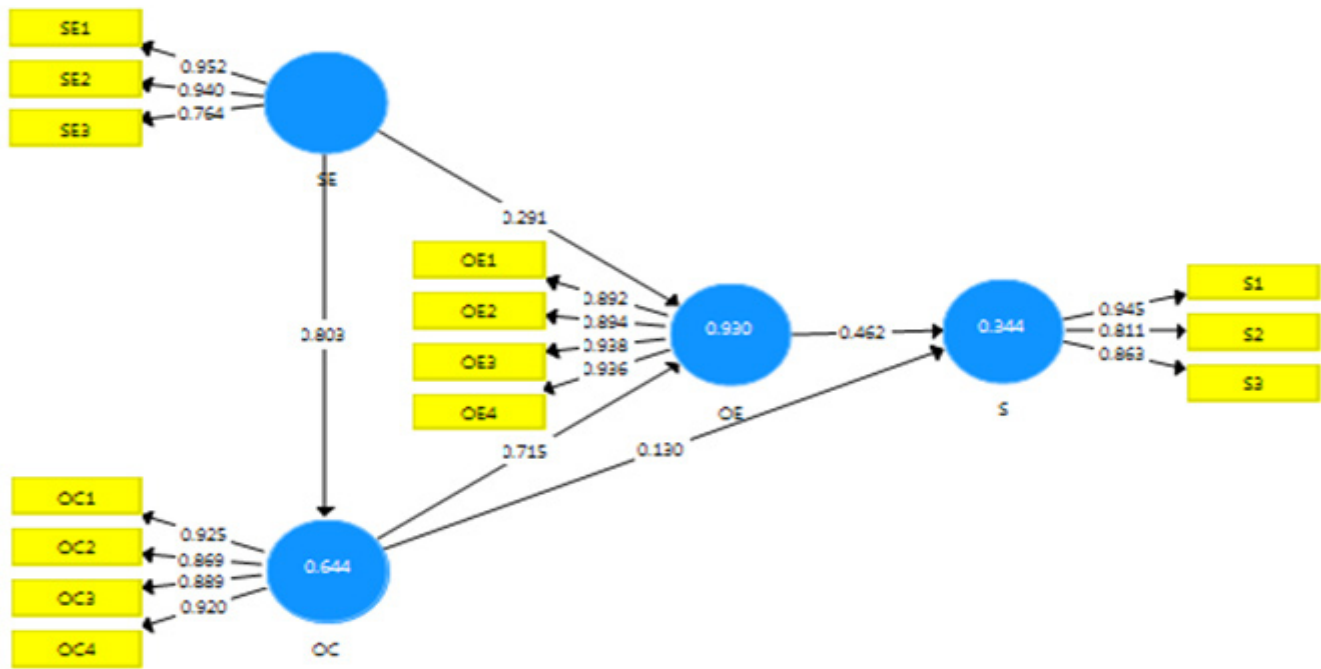

Figure 2. Result of the outer model

Table 3. Value of the R-square

Latent variable of endogenous	R-square
Organizational culture	0.644
Organizational Effectiveness	0.930
Sustainability	0.344

Table 4. Assessment of the structural model

Pathway	Original sample (O)	Sample mean (M)	Standard Error (STERR)	T-Statistics	Information
SE → OC	0.803	0.802	0.044	18.201	Direct Effects
SE → OE	0.291	0.290	0.058	4.981	Direct Effects
OC → OE	0.715	0.717	0.059	12.091	Direct Effects
OC → S	0.130	0.123	0.376	0.346	Direct Effects
OE → S	0.462	0.474	0.363	1.273	Direct Effects
SE → S	0.504	0.513	0.068	7.419	Indirect Effects
SE → OE	0.574	0.580	0.058	9.969	Indirect Effects
OC → S	0.331	0.331	0.290	1.142	Indirect Effects

The influence of social entrepreneurs on organizational culture

Based on bootstrapping results, it can be explained that social entrepreneurs (SE) have a positive and significant influence on organizational culture (OC). This can be seen from the path coefficient of 0.803 with a t-statistic value of 18.201 > t-table (1.96). This means that with better encouragement from social entrepreneurs (Chairman of the DPPT) towards organizational culture, the stronger the culture of the organization in the SPR

Ngudi Rejeki. Acar (2012), who said that a leader has an influence on organizational culture, starting from forming organizational culture, developing, and changing organizational culture. The Chairperson of the DPPT has a strategic role in running the SPR such as building a work environment since SPR members will depend on what they know. Schein also reinforces the study results in Muthiane et al. (2010), a leader who starts the initial process of forming organizational culture by imposing values, beliefs, and assumptions of action at the beginning of the organization. In addition,

Warrick's (2017) research is also in line with this study that leaders influence organizational culture, ie leaders who pay attention to the success of the members' performance will positively impact cultural norms.

Empirical findings in the research, namely the Chairman of the DPPT made a registration policy for new members, namely breeders who want to join the SPR Ngudi Rejeki Kediri members must be willing to have their cattle recorded every month by the SPR. The program is carried out from one cage to another until all the SPR members' cows are finished recording. One of the goals of the program is to build teamwork relationships among members. The members without being governed by the Chairman of the DPPT automatically took turns removing the cow from the cage to the scales and putting it back into the cage.

The Chairperson of the DPPT provides motivation to members through both chat group and regular monthly meeting of the SPR Ngudi Rejeki, so it will indirectly add insight to SPR members because the knowledge shared will not diminish but will bring blessings instead. The Chairperson of the DPPT also provides open opportunities for SPR members to ask if there are obstacles in completing work.

Every direction from the Chairman of the DPPT both in personnel and as stated in the SPR policy will certainly encourage the stronger culture of the SPR Ngudi Rejeki. In addition, what needs to be considered by the Chairman of the DPPT is consistency to continue to reward the performance of members who are able to increase the weight of their cows well even though it's not of monetary value. This can cause complacency and increase self-confidence which will have a positive impact on cultural values. Success tends to unite and instill pride in the SPR and make the SPR culture stronger. Therefore, celebrating success and communicating the success achieved by members in person and SPR can be built with culture.

The influence of social entrepreneurs on organizational effectiveness

Table 4 shows that social entrepreneurs have a positive and significant influence on organizational effectiveness. This means that with better leadership from social entrepreneurs, higher organizational effectiveness will be achieved. Taylor et al reinforced the study results, said that a chairman plays an important role in

organizational effectiveness and the results of research conducted by Mishra and Misra (2017), that social entrepreneur have a positive and significant influence on organizational effectiveness.

Based on the findings in this study, an effective organization is triggered by social entrepreneurial factors. The Chairman of the DPPT first conduct a thorough analysis in every decision-making made to face the problems of SPR Ngudi Rejeki. The Chairman of DPPT Ngudi Rejeki Kediri also provided insights into the social benefits felt by members and the community from this collective effort. Then, the Chairman of the DPPT also helps SPR members adapt to the new environment by eliminating the traditional pattern of less effective breeders towards more effective cultivation.

The Chairperson of the DPPT provides inspiration from personal experience, social networks and social problems that occur, so it is easy to explain new ideas that can be accepted by SPR members. In addition, the Chairperson of the DPPT also stimulates SPR members' minds to increase their performance, which is realized by giving confidence to SPR members to be more creative and innovative. Thus, the aforementioned factors can trigger SPR members to work optimally in achieving organizational effectiveness.

SPR Ngudi Rejeki Kediri has been effective, this has been proven by the Kinarya Satwasentosa award. The award includes six criteria including: being able to be independent in the congregation, anti-ignorance and love of innovation, joint efforts of the middle class, to be stronger in the synergy between institutions, there is a high enthusiasm in strengthening institutions and having started a collective business.

The influence of social entrepreneurs on sustainability

Based on the results of the bootstrapping test in table 4, it shows that social entrepreneurs have a positive and significant influence indirectly on sustainability. This can be seen from the path coefficient of 0.504 with a t-statistic of $7.419 > 1.96$. This means that the sustainability of the SPR Ngudi Rejeki Kediri will be more established in the future if the social entrepreneur (DPPT chairman) is better at leading the SPR. The results of the study are strengthened by previous research that social entrepreneur has a positive effect on organizational sustainability (Alex, 2015). The

research results of Caroline (2017), are also in line with this study that social entrepreneurs have a positive contribution in running social entrepreneurship.

The Chairman of the DPPT SPR Ngudi Rejeki is a key element in running the SPR. The DPPT chair's policy determines all SPR decisions and plans that will be carried forward. Social entrepreneur factors that can preserve SPR sustainability in the future include: social passion, innovativeness, and pro-activeness. There are two types of social entrepreneurs in social entrepreneurship; those who actively work to improve community resilience by generating additional income and those who prefer to act as enthusiasts (Caroline, 2017). Chairman of DPPT SPR Ngudi Rejeki wishes to create SPR sustainability stated specifically in the research's empirical findings.

Empirical findings from social passion factors are that the DPPT chairperson focuses on creating social values with all SPR policymaking felt by members of the SPR Ngudi Rejeki Kediri and the general public such as, the chairperson of the DPPT provides insights from personal experiences to SPR members regarding effective cultivation methods and efficient starting from the feeding, livestock care, costs that must be spent for each cow per day, and the time required for fattening on a business scale. This provides inspiration for members to improve their performance because being SPR members allows them to improve their financial condition. The Chairman of the DPPT also opened as many partnerships as possible with investors, facilitated by the SPR Ngudi Rejeki's cooperative with one-door management, which impacted the SPR members to increase the capacity of their cages using loans from the cooperative's money, which indirectly open employment opportunities for non-breeder communities. In addition, Chairman of the DPPT builds a network with surrounding communities that sell green feed and agricultural waste that can be used as animal feed, making it easier for SPR members to get feed.

Innovative factors, the head of the DPPT SPR Ngudi Rejeki took several innovative actions for the sustainability of the SPR going forward, namely the head of the DPPT seeking livestock insurance for SPR members which is a new idea so that members need not fear if there is an event from their cow dying. Another thing the Chairman of the DPPT began to innovate in

making animal feed with feed composition in accordance with the needs of livestock and low prices for members. In addition, the Chairman of the DPPT adopted a policy regarding sharing with partnerships of 65 percent for SPR members and 35 percent for investors, this would be very beneficial for farmers because the rules that apply in the community are generally 50 percent for investors and 50 percent for farmers. Another idea conveyed by the Chairman of the DPPT was to look for additional income by providing education to traders and breeders in the cattle market through a cattle scales service that costs five thousand rupiahs. The Chairman of the DPPT provides motivation by comparing the results of managing an area of a one-seventh hectare with the same result as maintaining one beef cattle, considering buying one-seventh hectare of land costs around two hundred and fifty million rupiahs while one cow is around twenty million rupiahs.

Pro-activeness factor, where the Chairman of the DPPT sees SPR Ngudi Rejeki has potential opportunities going forward that will positively impact the welfare of farmers, social impacts on non-farmer communities, as well as providing benefits to the environment. Every problem that occurs in the SPR, the Chairman of the DPPT does not blame others but prefers self-introspection and is responsible for finding solutions to these problems.

The focus of the Chairman of the DPPT is to make SPR Ngudi Rejeki an expert in fattening beef cattle. This is evidenced by the experiment in making animal feed conducted by the Chairman of the DPPT starting from his own farm before being spread to SPR members. In addition, the Chairperson of the DPPT is actively providing education to the surrounding community about the benefits obtained by joining SPR and benefits gained by switching from traditional breeders to professional breeders. Not only that, the Chairman of the DPPT continued to take various actions to look for opportunities that could have an impact on the sustainability of the SPR Ngudi fortune in the future, such as establishing communication with various government agencies that could support the development of the SPR going forward. This is a gift in the head of the DPPT for self-awareness in maintaining the sustainability of the SPR Ngudi Rejeki with a conscience and creative imagination of experience and sensitivity to the environment.

The influence of organizational culture on organizational effectiveness

Organizational culture has on organizational effectiveness with a t-statistic value of $12.091 > \text{table } (1.96)$. This means that the SPR Ngudi Rejeki will be more effective if the cultural value in the Ngudi Rejeki SPR gets higher. These results are consistent with previous research conducted by Arefin (2015) and Daneshmandnia (2019), that organizational culture positively influences organizational effectiveness. Research findings are also strengthened by (Zheng et al. 2010) regarding the relationship between organizational culture and organizational effectiveness.

Empirical findings of organizational culture in this study, namely the existence of regular monthly meetings at 20th held by SPR Ngudi Rejeki. The meeting discussed the evaluation of the recording and the awarding of members who had good performance in raising the weight of their livestock, then the member was given the opportunity to share their performance experience for one month so that they could motivate other members. In addition, the involvement of members in every decision-making that will be taken by the SPR such as the SPR does not provide loans in the form of money but in the form of feed produced by the SPR and loans to renovate the cage. Loyalty from high SPR members can be seen from every SPR activity starting from recording, routine meetings and other activities. The presence of SPR members reaches 85 percent, it is that members hold firm to the SPR Ngudi Rejeki rules. Adjustment of the organization's ability to open as many partnerships as possible, namely the SPR began to improve from the internal organization, such as improving the member cages for greater capacity because it was deemed important for the progress of the SPR Ngudi Rejeki going forward.

The influence of organizational culture on sustainability

Bootstrapping test results presented in table 4 show that organizational culture has no significant or indirect effect on sustainability. it means that the organizational culture of SPR Ngudi Rejeki has not been well formed. Previous researchers that organizational sustainability is influenced by organizational culture (Dyck et al. 2019). The cultural strength in each organization varies depending on the cycle of the organization (Belak, 2016). Where the longer the organization reaches,

the stronger the culture of the organization. The most important is how culture can foster collaboration and sharing to overcome limited resources and increase new opportunities by maintaining a culture of sustainable learning as part of company culture (Kumar and Sharma, 2018).

Research findings based on data processing results show that the most dominant cultural characteristics in the SPR Ngudi Rejeki Kediri is Clan Culture at 28.33%. The culture in the SPR Ngudi Rejeki is familial; prioritizing teamwork, unity, and participation of SPR members in organizational activities; a sense of togetherness; and SPR's commitment to its members. The success of the SPR Ngudi Rejeki can be managed well through joint work (not individual ones), while the development of members and customers is considered a partner.

SPR Ngudi Rejeki members expected that in the future culture of SPR Ngudi Rejeki will be more advanced than now and have a long existence is a reflection of adhocracy culture (27.5%). Characteristics of an adhocracy culture are organizations are oriented to innovation so that the SPR can quickly respond to changing needs that will occur in the future. The main objective of adhocracy culture is to build an entrepreneurial spirit and bring out the creativity and innovation of SPR members that might bring organizational success, especially in the development of new products or services. Thus, SPR Ngudi Rejeki can choose the main priorities that need to be developed from the perspective of organizational culture to maintain the organization's sustainability in the future.

The influence of organizational effectiveness on sustainability

Organizational effectiveness has not significant effect on sustainability. This can be seen from the path coefficient value of 0.462 with a t-statistic value of $1.273 < 1.96$. The results of the study reinforce the organizational effectiveness perspective proposed by Gibson et al. (1985) with a systems approach, if one part of an organization is weak it will have a effect on the entire organizational system.

This study provides empirical findings that led to the effectiveness of the SPR Ngudi Rejeki negatively affecting the sustainability of the SPR, namely there are weaknesses in the management structure of SPR Ngudi

Rejeki that prevents it to work optimally. Another thing, the SPR did not formally issue the objectives to be achieved, so that the SPR was not maximal in measuring the organizational achievements. In addition, SPR members not only work as farmers but also have other jobs including: civil servants, teachers, doctors, traders, private employees and concurrent breeders besides beef cattle. It is also one of the factors that negatively influence the effectiveness of the SPR SPR negatively affecting the sustainability of the Ngudi Rejeki in the long term because members are unable to focus on their role.

Managerial Implication

In the managerial aspect, the organization still needs constant assistance to ensure the independence of the SPR to be a collective company that is managed professionally and proportionally. For advanced researchers, research on social entrepreneurs needs to be carried out on the sustainability of SPR mediated by knowledge management, organizational structure.

CONCLUSIONS AND RECOMMENDATIONS

Conclusions

The findings of this research provide new insights in the field of animal husbandry, especially the School for smallholder communities. First, this study reveals how a social entrepreneur (Chairman of the DPPT) has a major influence on organizational culture formation in social entrepreneurship. Because it is not easy for a chairperson of the DPPT to change the pattern of behavior of farmers who have traditionally gone down to the professional breeders. Second, social entrepreneurs have a positive and significant effect on organizational effectiveness. This means that the better the social entrepreneur in leading the SPR Ngudi Rejeki, the more effective the SPR will be. Third, social entrepreneurs indirectly have a positive and significant effect on the sustainability of SPR Ngudi Rejeki's development. This means that the factors of social passion, innovation, and pro-activeness from the Chairman of the DPPT are necessary to maintain the long-term survival of SPR, as social entrepreneurs are ready to work for farmers' interests the community. Fourth, organizational culture has a positive and significant effect on organizational effectiveness. This means that the SPR Ngudi Rejeki will be more effective if the culture in

the SPR is strengthened. Fifth, organizational culture has not significant effect directly or indirectly on the sustainability of the SPR Ngudi Rejeki Kediri. Today's dominant cultural characteristic is clan culture, for the culture expected by SPR members advancement is the adhocracy culture. Sixth, organizational effectiveness has not significant effect on the sustainability of SPR Ngudi Rejeki.

Recommendations

Researchers recommend to the SPR Ngudi Rejeki namely, during the election of the Chairman of the DPPT SPR Ngudi Rejeki, consider applying social entrepreneurship criteria, including social passion, innovativeness, and pro-activeness factors as a requirement. This can maintain the sustainability of the SPR in the future because social entrepreneurs are able to create social values, innovate, empower others, and are accustomed to dealing with social problems with good planning. Each meeting of the Chairperson of the DPPT needs to convey the vision and mission of the SPR so that it will be attached to the SPR members, finally being able to clarify the purpose of the SPR. Finally, the SPR Ngudi Rejeki needs to improve the organization's structure so that no one holds someone outside the community holds a concurrent position and the SPR Manager position in accordance with LPPM IPB guidelines.

REFERENCES

- Acar A, Zafer. 2012. Organizational culture, leadership styles and organizational commitment in Turkish logistics industry. *Social and Behavioral Sciences* 58:217–26.
- Alex OVAHC. 2015. Leadership style of sustainability professionals in the UK construction industry. *Built Environment Project and Asset Management* 5(2):184 - 201
- Arefin M, Shamsul B. 2015. The impact of business intelligence on organization's effectiveness: an empirical study. *Journal of Systems and Information Technology* 17(3):263–285
- Belak J. 2016. Management and governance: organizational culture in relation to enterprise life cycle. *Kybernetes* 45(4):1-24
- Bernadino et al. 2018. Social Entrepreneur and Gender : What's Personality Got to Do with It ? And Gender. *International Journal of Gender*

- and *Entrepreneurship* 10(1):61–82.
- Caroline MERDB. 2017. The role of social entrepreneurs in developing community resilience in remote areas. *Journal of Enterprising Communities: People and Places in the Global Economy* 11(1):1-27.
- Daneshmandnia A. 2019. The influence of organizational culture on information governance effectiveness. *Records Management Journal* 29(1):19-41.
- Dyck Dyck BK, Arran C. 2019. Antecedents of sustainable organizing : a look at the relationship between organizational culture and the triple bottom line. *Journal of Cleaner Production* 231(2019): 1235–1247.
- Ebrashi RE. 2013. Social entrepreneurship theory and sustainable social impact. *Social Responsibility Journal* 9(2):188 – 209.
- Elkinjton J. 1998. Partnerships from Cannibals with Forks : The Triple bottom line of 21st Century Business. 37–51.
- Ghalwash S, Tolba A, Ismail A. 2017. What motivates social entrepreneurs to start social ventures? an exploratory study in the context of a developing economy. *Social Enterprise Journal* 13(3):268-298.
- Ghozali I. 2014. *Structural Equation Modeling, Metode Alternatif dengan Partial Least Square (PLS)*. Edisi 4. Semarang: Badan Penerbit Universitas Diponegoro.
- Ikhwan K., Sukmawati A, Cahyadi ER. 2018. The Implementation of learning organization in order to increase supply chain performance in SPR Maju Bersama Bojonegoro. *Jurnal Manajemen dan Agribisnis* 15(1):83–95.
- Ilyas S, Abid G, Ashfaq F. 2020. Ethical leadership in sustainable organizations: the moderating role of general self-efficacy and the mediating role of organizational trust. *Sustainable Production and Consumption* (22): 195-204.
- Kumar N, Sharma DD. 2018. The role of organisational culture in the internationalisation of new ventures. *International Marketing Review* 35(5):806-832.
- Martono S, Wijayanto A. 2014. Peningkatan efektivitas program studi di perguruan tinggi swasta melalui kepemimpinan adaptif integratif. *Jurnal Dinamika Manajemen* 5(1):103–120.
- Mehdibeigi N, Deghani M. 2016. Customer knowledge management and organization's effectiveness : explaining the mediator role of Organizational Agility. *Procedia - Social and Behavioral Sciences* 230(May):94–103.
- Mishra P, Misra RK. 2017. Information Technology and Quantitative Management (ITQM) entrepreneurial leadership and organizational effectiveness: a comparative study of executives and non-executives. *Procedia Computer Science* 122:71–78.
- Muhammad N, Ida M. 2015. Pengaruh motivasi kerja, budaya organisasi, dan kualitas kehidupan kerja terhadap kinerja karyawan. *Management Analysis Journal* 4(3):219–228.
- Muslim MI, Sukmawati A, Syafitri UD. 2017. Implementasi organisasi pembelajar bagi keberlanjutan UKM klaster kerajinan batik di Cirebon. *Jurnal Manajemen Teknologi* 16(3): 294–309.
- Muthiane MC et al. 2010. Management & Organisational Behaviour. *Journal of Clinical Pathology* 4: 835.
- Narayanan V, Boyce G. 2018. Exploring the transformative potential of management control systems in organisational change towards sustainability. *Accounting, Auditing & Accountability* 32(5): 1211-1239.
- Rahman AA, Wong F. 2013. Training and organizational effectiveness : moderating role of knowledge management process. *European Journal of Training and Development* 37(5):472-488.
- Renko M. 2013. Early Challenges of nascent social entrepreneurs. *Entrepreneurship Theory and Practice* 312:1045–1069.
- Satar MS, Natasha S. 2019. Individual social entrepreneurship orientation : towards development of a measurement scale. *Asia Pacific Journal of Innovation and Entrepreneurship* 13(1):49–72.
- Saxena G. 2017. Multidimensional competency construct for social entrepreneurs: a logistic regression approach *Kasetsart Journal of Social Sciences* 1–5.
- Susmiati, Sudarma K. 2013. Pengaruh Budaya Organisasi dan Dukungan Organisasi Persepsi terhadap Kinerja PT. Augrah Raharjo Semarang. *Management Analysis Journal* 2(2):1–9.
- Tahapary JF, Martono S. 2017. Pengaruh budaya organisasi, stres kerja, dan komitmen efektif terhadap keinginan keluar. *Management Analysis Journal* 6(1):90-101.
- Taylor CM et al. 2014. Visionary leadership and Its relationship to organizational effectiveness. *Leadership & Organization Development Journal* 35 (6):566 - 583.

- Umniyyati R, Martono S. 2017. Pengaruh budaya organisasi, efikasi diri, harga diri, pada kinerja perawat. *Management Analysis Journal* 6(2):137-143.
- Warrick DD. 2017. What leaders need to know about organizational culture. *Business Horizons* 60(3):395–404.
- Zheng W, Yang B, Mclean GN. 2010. Linking organizational culture, structure, strategy, and organizational effectiveness: Mediating role of knowledge management. *Journal of Business Research* 63(7):763–771.