



Newcastle University ePrints

Widmer JD, Spargo CM, Atkinson GJ, Mecrow BC.

[Solar Plane Propulsion Motors With Precompressed Aluminum Stator Windings.](#)

IEEE Transactions on Energy Conversion 2014, 29(3), 681-688.

Copyright:

© 2014 IEEE. Personal use of this material is permitted. Permission from IEEE must be obtained for all other uses, in any current or future media, including reprinting/republishing this material for advertising or promotional purposes, creating new collective works, for resale or redistribution to servers or lists, or reuse of any copyrighted component of this work in other works.

Link to published article:

<http://dx.doi.org/10.1109/TEC.2014.2313642>

Date deposited: 11th February 2015

ePrints – Newcastle University ePrints

<http://eprint.ncl.ac.uk>

Solar Plane Propulsion Motors with Pre-Compressed Aluminium Stator Windings

J. D. Widmer, C. M. Spargo, *Member, IEEE*, G. J. Atkinson, and B. C. Mecrow, *Member, IEEE*

Abstract— This paper reports a propulsion motor for a solar powered aircraft. The motor uses pre-compressed aluminium stator windings, with a fill factor of greater than 75%, in a permanent magnet synchronous machine (PMSM). The motor performance is compared empirically to an identical machine with conventionally wound copper windings. It is shown that there are many advantages to using compressed aluminium windings in terms of weight reduction, thermal improvement and lower cost, for the same loss and electromagnetic performance, provided a sufficiently high slot fill factor can be achieved. The design and manufacture of the compressed coils is also discussed. A modular stator arrangement is used, in the form of a solid coreback with keyed teeth to allow easy assembly of the compressed windings. It is noted that the electromagnetic performance of the machine is unaffected by the modular nature of the magnetic core. Two prototype motors, one wound with conventional copper and the other with pre-compressed aluminium windings, are constructed and tested.

Index Terms—Compressed windings, aluminium windings, fill factor, high efficiency, electric motor, aerospace, solar plane.

I. INTRODUCTION

ALUMINIUM has been widely used for many years as a conducting material in applications such as power distribution and low cost electrical machines, particularly in induction machine rotors [1, 2]. However copper has tended to maintain a dominant position in the development of higher performance motors, due primarily to its high electrical conductivity. In motor applications, aluminium has many advantages over copper [3, 4], including:

- Low mass density – only 30% that of copper - important in applications where motor mass is a significant consideration;
- Low cost – approximately only 10% the cost per unit volume of copper and 30% per unit mass [5];
- High thermal heat capacity – approximately double that of copper per unit mass, important in overload conditions;

This paper is an outcome of work undertaken as part of the Boeing SolarEagle aircraft development project and was funded by U.S. Government Defense Advanced Research Projects Agency (DARPA). The views expressed are those of the authors and do not reflect the official policy or position of the Department of Defense or the U.S. Government. Distribution Statement “A” (Approved for Public Release, Distribution Unlimited).

The authors are with the School of Electrical and Electronic Engineering, Newcastle University, Newcastle-upon-Tyne, NE1 7RU, UK (e-mail: james.widmer@ncl.ac.uk; c.m.spargo@ncl.ac.uk; glynn.atkinson@ncl.ac.uk; barrie.mecrow@ncl.ac.uk).

- Increased recyclability – Aluminium can be recycled with steel, whereas copper is a considerable contaminant in the steel recycling process. For most motor designs it is extremely difficult to separate the windings from the steel core without significant dismantling processes, making this an increasingly relevant issue [6].

These factors are of great interest to electrical machine designers. High thermal heat capacity may be important where there is a desire to operate motors in short term overload conditions. Low mass is important in the design of ‘mobile’ electrical motors for use in applications ranging from electric vehicles to the More Electric Aircraft. Low cost is always of interest and recyclability is of concern to all designers, driven by initiatives such as the European End of Vehicle Life Directive, which requires manufacturers to recycle a larger percentage of a vehicle at its end of life [7].

There are also challenges associated with the use of aluminium for stator windings, as follows:

- It only has two thirds the electrical conductivity of copper, making it less volume efficient, increasing the size of windings and therefore indirectly the mass of a motor, perhaps outweighing its benefits;
- The reliable and safe termination of Aluminium cables has also caused concern amongst consumers, particularly in the US [8];
- Concerns exist over the high temperature performance of aluminium conductors and particularly their ability to maintain their shape at temperatures above 150°C.

These issues must be addressed in order to fulfil the material’s promise as an electrical conductor in high performance electrical machines. The fundamental barrier to overcome is that of reduced electrical conductivity. To match the winding losses in a copper wound machine it is necessary to have 50% greater volume of aluminium winding, ideally without any increase in overall machine size. This paper proposes to achieve this using a very high fill factor ($\approx 75\%$), compressed aluminium coil.

The motor has been developed for use in an extremely demanding application, that of providing propulsion for a Solar Powered Aircraft. The use of such aluminium coils has enabled the design and construction of a machine with both lower mass and also reduced winding losses when compared to an electromagnetically equivalent machine with conventionally wound copper windings. The paper

investigates mitigations for some of the issues discussed above, and presents techniques to manufacture a motor with such high fill factor windings. Results are presented for two prototype motors: one using these compressed aluminium windings and one conventionally wound in copper, supporting the findings in this paper.

II. SOLAR PLANE MOTOR REQUIREMENTS AND CONSTRAINTS

The development of the perpetually flying, Solar Powered Aircraft has over recent years become a reality, with both the UK's QinetiQ Zephyr [9] [11] and Swiss Solar Impulse [10] aircraft demonstrating the technology's feasibility.

The motor described in this paper takes this work a step further. Developed to support Boeing's SolarEagle, a much larger solar powered aircraft [12], a new 6kW motor was required. The proposed motor design is required to offer extremely high efficiency during the aircraft's 'cruise' phase, with a very challenging mass requirement in order assist in the maintenance of very low aircraft weight. These requirements are contradictory; a larger motor will generally have higher efficiency and a smaller motor lower mass. The motor must also provide an extensive overload capability in order to support aircraft take-off, whilst being able to operate reliably at altitudes of up to 60,000ft, temperatures as low as -70°C and for a continuous duration of up to 5 years.

III. PROPOSED HIGH EFFICIENCY MOTOR DESIGN

For this new motor, a large diameter outer rotor Permanent Magnet Surface Mount (PM-SM) design was selected (Fig.1), based on the findings of the Zephyr project [7]. The authors' previous work [11] had shown that this design offered the optimum balance of low mass and low losses. A permanent magnet machine intrinsically offers the lowest losses for a small machine of this type, whilst an outer rotor design maximised the airgap diameter for a given active mass. Based on a simplistic analysis, large diameter rotors can be shown to require a lower magnetising field strength and therefore electrical loading to produce the same torque. Therefore a large diameter coupled with as short an axial length can be shown have lower winding losses. In order to reduce iron losses, a very low loss, 6.5% Silicon steel was used (10JNEX900 from JFE steel). This material has a 0.1mm lamination thickness and has specified losses of less than 14W/kg at a flux density of 1T and a frequency of 1kHz.

The resulting electrical machine was selected from a number of differing options, featuring differing slot and pole numbers, with the final design optimised to minimise loss at its key operating point. The motor was designed with the key features shown in Table I.

IV. SELECTION OF COMPRESSED ALUMINIUM WINDINGS

Copper windings are the standard choice for electric motors, owing to their high electric and thermal conductivities. However, in this application, where the motor mass is a major design constraint, the option of aluminium was also investigated, aiming to give the same electromagnetic performance but with lower mass for a given geometry.



Fig. 1. Prototype motor with compressed aluminium windings.

TABLE I
OUTER ROTOR PM-SM DESIGN PARAMETERS

Parameter	Value
Topology	3 Phase, Outer Rotor, surface mount permanent magnet motor
Slots / Poles	36 / 40
Series Turns per phase	207, single tooth wound, star connected
Airgap diameter	223.8mm
Stack Length	25.8mm
Airgap Length	0.8mm
Rated Power	6kW
Maximum Torque	60Nm
Maximum Speed	1300rpm
Rated Current	45A(rms)
DC Link Voltage	270V

The ohmic winding loss in an electrical machine is calculated to be:

$$P_w = \frac{n \cdot m \cdot MMF_s^2 \cdot l_{av}}{\sigma \cdot S_{FF} \cdot A_{slot}} \quad (1)$$

Where ' m ' is the number of phases, ' n ' is the number of coils per phase, ' l_{av} ' is the average turn length in a coil, ' σ ' is the winding material electric conductivity, ' S_{FF} ' is the slot fill factor, ' A_{slot} ' is the slot area and ' MMF_s ' is the coil rms MMF given by;

$$MMF_s = N_{coil} \cdot I_{ph} \quad (2)$$

' N_{coil} ' is the number of series turns per phase and ' I_{ph} ' is the rms phase current.

It is evident that for the same machine geometry, the number of phases, number of coils per phase and the slot area are fixed. If it is assumed that the average turn length is also fixed then the material conductivity and the slot fill-factor become the remaining variables. Assuming that a fixed MMF is required in order to produce the desired motor torque, then

it is these variables which will evidently define the level of winding loss in the motor.

Mass is a critical aspect of the solar propulsion motor. The mass density of copper (ρ_{Cu}) is 8940 kg/m³ and for aluminium (ρ_{Al}) it is 2700 kg/m³. The mass ratio of the two windings is given by:

$$\partial_{mass} = \frac{m_{Al}}{m_{Cu}} = \frac{\rho_{Al} S_{FF}^{Al}}{\rho_{Cu} S_{FF}^{Cu}} \cong 0.302 \frac{S_{FF}^{Al}}{S_{FF}^{Cu}} \quad (3)$$

Therefore for the same slot fill factor, replacing copper with aluminium results in a reduction in the mass of the windings to 30% of the initial value. However the lower conductivity of aluminium also needs to be considered and so it is also necessary to take into account the electrical conductivity of the two materials when considering the electrical resistance ratio:

$$\partial_R = \frac{R_{Al}}{R_{Cu}} = \frac{\sigma_{Cu} S_{FF}^{Cu}}{\sigma_{Al} S_{FF}^{Al}} \cong 1.638 \frac{S_{FF}^{Cu}}{S_{FF}^{Al}} \quad (4)$$

At 20°C the electrical conductivities are $\sigma_{Cu} = 58.0 \times 10^6$ S/m and $\sigma_{Al} = 35.4 \times 10^6$ S/m. Both materials have similar thermal coefficients of conductivity, hence this ratio remains valid across a wide range of temperatures.

From above, it is clear that for the same slot fill factor, mass is reduced by 70% but resistance rises by 64%. It is now possible to trade off mass reduction for equivalent winding loss by setting $\partial_R = 1$, which forces the loss, ' P_w ' to meet the constraint;

$$P_w^{Al} = P_w^{Cu} \quad (5)$$

For this condition the slot fill factor of the aluminium winding must rise by 64%, but the mass of the winding will still be only 49% that of the copper winding.

Assuming a copper wound machine with a fill factor of 45%, a typical upper limit for hand wound coils, the aluminium wound machine would need a slot fill factor of 74%. Because the windings are wound round single teeth it is possible to bobbin wind them off the machine, with subsequent assembly of the stator from a number of components. However, a 74% slot fill factor even exceeds the limits of conventional bobbin winding techniques. Consequently it was decided to try and extend the work, investigating the compression of windings, previously undertaken by the authors' [13], in order to further increase the achievable slot fill factor.

In [13] it was shown that copper windings could be pre-compressed under high pressure in order to achieve a fill factor of up to 80%. The application of this process to aluminium windings could therefore lead to reductions in winding mass, whilst matching the winding resistance of conventional copper windings.

The use of aluminium windings were predicted to reduce the winding mass from 2.03kg to 1.02kg, a 50% winding mass

reduction, which equates to around a 12% mass reduction for the same output torque and loss.

V. WINDING CONFIGURATION SELECTION

The machine has a fractional slot concentrated winding. The twelve coils per phase were arranged into four parallel paths (Fig. 2), with each coil comprising 69 turns: it had been found that series connection would require a wire diameter of over 2.0mm, which would give unacceptably high proximity loss. Detailed finite element analysis showed that a reduction in wire diameter to 1.4mm or less would reduce such losses to negligible levels at the required operating points. This analysis was undertaken for copper windings but would also be acceptable in an aluminium winding, as proximity losses are inversely proportional to material conductivity.

Whilst the parallel configuration carries the potential for additional ohmic winding loss due to circulating currents between the parallel coil paths, this risk was considered to be low for this class of machine.

Two magnetically identical machines were constructed, both making use of this winding configuration. The first, with conventional windings, used 1.06mm diameter, grade 2 class H copper wire offering a 43% fill factor. The second machine, constructed with compressed aluminium windings, would utilise 1.4mm diameter, grade 2 class H aluminium wire and achieve a fill factor of 75%. These winding configurations are compared in Table II.

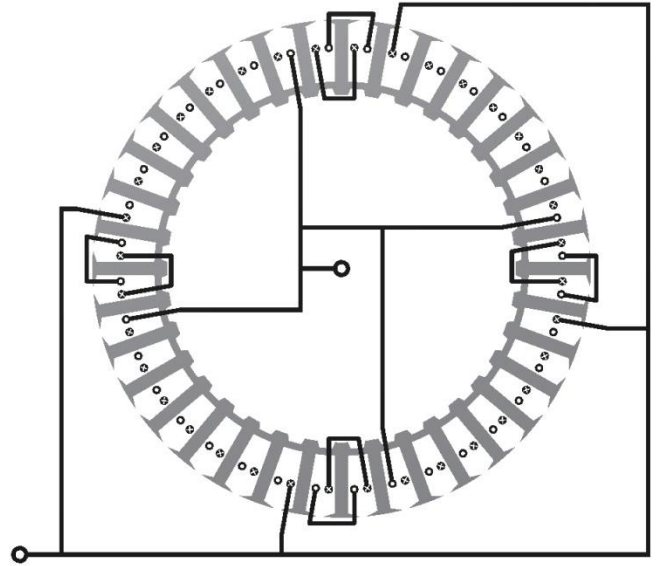

Fig. 2. Selected fractional slot winding configuration (single phase shown).

VI. COMPRESSED ALUMINIUM COIL CONSIDERATIONS

A. Coil Manufacture

In order to reliably achieve the required fill factor it is necessary to compress the motor windings before assembling them into the motor. As had been previously applied to copper windings, this was achieved through the use of a specially manufactured bobbin, punch and die set (Fig. 3). The tool pieces are designed such that when the bobbin and punch are fitted into the die a void forming the final shape of the coil,

minus any predicted material ‘spring-back’, remains. ‘Spring-back’ is governed by elastic recovery of the material and is influenced by the Young’s Modulus and yield strength of the material, with aluminium and copper having different responses as will be seen.

TABLE II
WINDING CONFIGURATIONS FOR COPPER AND ALUMINIUM WOUND MOTORS (PREDICTIONS)

<i>Motor Parameters</i>	<i>Cu Windings</i>	<i>Al Windings</i>
Winding Configuration	4 sets of three adjacent series coils per phase, Star connected	4 sets of three adjacent series coils per phase, Star connected
Number of Turns	69 per coil (equiv. 207 per phase)	69 per coil (equiv. 207 per phase)
Winding Material	Grade 2, Class H Copper	Grade 2, Class H Aluminium
Conductor Diameter	1.06mm	1.4mm
Fill Factor	43%	75%
Phase Resistance	0.100 Ohms	0.090 Ohms
Phase Inductance	727 μ H	727 μ H
Motor Mass	7.06kg	6.22kg



Fig. 3. Compressed winding die (left) suitable for compaction of 6 coils. Compressed coil fitted to bobbin, pictured with punch above (right).

An essential element in achieving a high fill factor is to ensure that the windings are laid-up on the bobbin such that they are distributed evenly and in the relative position in which they will occupy once the coil is pressed. If this approach is not followed then some parts of the cross sectional area of the pressed coil may have a very high winding density where other areas are less dense, reducing total coil fill factor. It is also important that the position of the coil terminations in the bobbin wound coil is considered as it is also critical that they be located in a position which will allow them to be accessed once assembled with the completed machine.

The coils are wound onto the bobbin and wrapped with a thin (0.03mm) Kapton tape in order to hold them in place and to provide a level of abrasion protection at the outside surface of the coil. The bobbin is inserted into the die and then punch fitted in place. Using in this case a 15 tonne workshop press, a uniformly increasing pressure is then applied to the punch until it pressed flush with the top surface of the die. For copper windings this has been previously been found to require pressure in the order of 400MPa. However using aluminium

the required pressure was reduced, totalling only 250MPa. This is thought to be due to the higher malleability of the aluminium conductor compared to the copper allowing a lower pressure to be used in forming the coil. This effect is also seen when the pressure is removed from the punch. With copper coils there is a significant spring-back in the order of 2-3% whereas with aluminium this is far less pronounced, moving only 0.5-1%. This reduced spring-back is to be expected as pure aluminium has a lower Young’s Modulus than copper (70GPa versus 130GPa), which would result in a lower material elasticity, coupled to having a lower yield strength (20MPa versus 33MPa), providing a greater tendency to retain the deformation due to the coil compression.

The pressed coil is then removed from the die, the Kapton tape removed and the terminations exposed (Fig. 4). The figure shows clearly how the compression of the coils has led to a close hexagonal packing of the coil’s conductors, removing air voids completely. The even distribution of enamel between the conductors can also be clearly seen; testing (see Section VI.E) has shown that as a result turn to turn faults are unlikely during compression.

B. Stator Design for Compressed Coils

A stator design is required which allows the pressed coil to be fitted to the stator tooth.

Several existing designs were considered. An open slot design, such as [14, 15], was assessed but found to have unacceptably high winding proximity losses.

A number of methods of allowing compressed winding assembly, using modular stator yoke components, were also assessed [16-19]. These each raised concerns over the effect on motor performance of the gaps which would be left between stator yoke components during assembly.

In order to address these limitations the so called ‘keyed tooth’ design was developed. This design attached the stator tooth to stator coreback through the use of a tapered, precision fit ‘key’ (see Fig. 5 and Fig. 6) This would allow the coil to be assembled first to the tooth which could then in turn be fitted into coreback.

The rationale for the selection of this method is that previous research has shown that compressive stress in motor laminations increases iron loss [20] whilst reducing permeability [21], therefore also increasing winding losses. As a result there is a need to avoid any mechanism that builds compressive stress into the tooth root. The use of a precision fit taper met this requirement and it was possible to manufacture this tapered key and keyway to the tolerances required (+/- 0.02mm) through the use of an Electrical Discharge Machining (EDM) wire erosion machine. For the low manufacturing volumes and throughput required for the construction of solar powered aircraft, this was considered to be an appropriate manufacturing process.

A 1 degree taper angle was selected as this allowed a good, consistent fit whilst maintaining sensible diameters for the keyway at each end; avoiding the need for very small and fragile features. As can be seen in Fig.5, a castellated coreback design was selected for the prototype; this increased the available area for keyway opening whilst also providing a mechanical interface with the rotor support structure without significant increase in total motor mass.

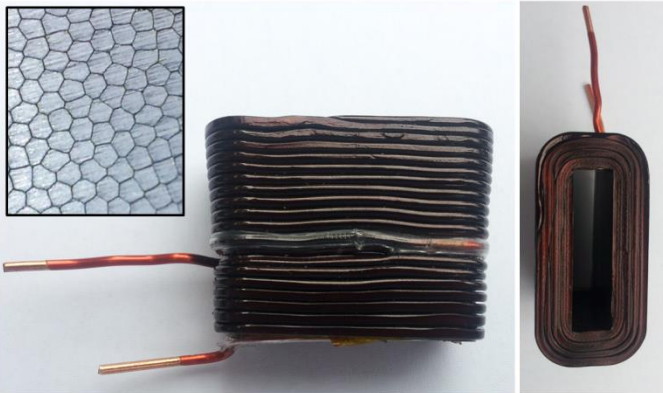

Fig. 4. Compressed coil showing copper interconnecting leads. Inset shows the level of compression achieved at 250MPa (~2x magnification).

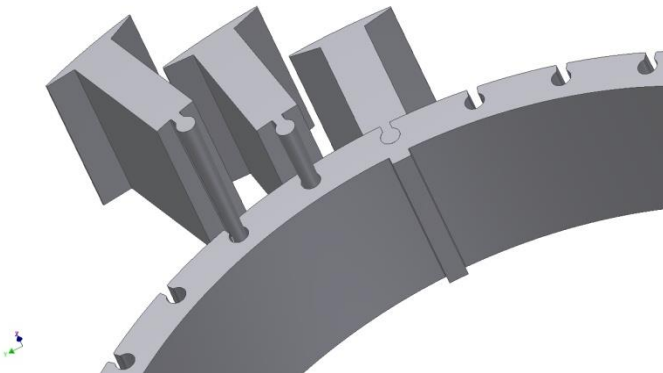

Fig. 5. Showing the keyed tooth stator coreback and tooth concept which enables the use of compressed windings.

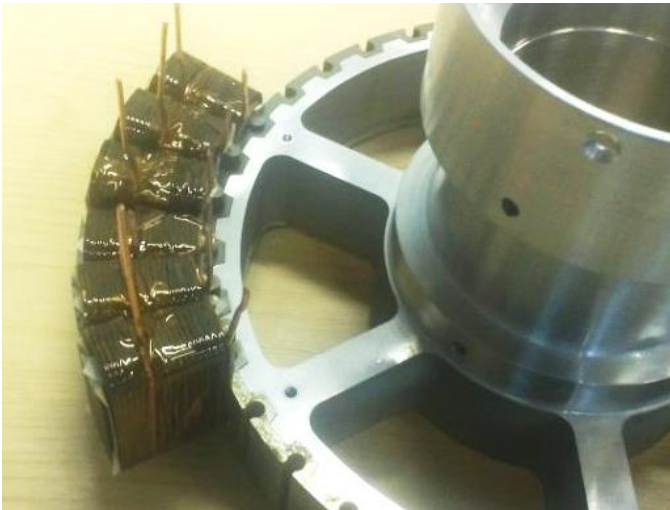

Fig. 6. Aluminium wound motor during construction showing six coils, assembled with their keyed teeth, attached to the motor.

The use of keyed tooth had a further benefit of reducing the radius of the single piece stator from circa 225 mm to circa 170mm for the keyed coreback (minus separate teeth). This design allowed all stator teeth to be cut from the centre of the stator lamination blank reducing scrap by more than 50%, a significant saving where such a high cost material was used.

The coil was insulated from the tooth using 0.2mm Nomex slot liner, cut from sheets printed with a cutting template. The tooth was then gently slid into the stator coreback with the final 1 to 2 mm requiring a gentle tap with an aluminium drift.

One further benefit was identified. Whilst additional tooling was required to allow for the manufacture of the compressed coils, once this had been perfected the time to wind the machine was greatly reduced and the process deskilled, when compared to manual winding with closely fitting end windings. The conventional machine took a skilled operative in the region of 6 working days to wind whilst the aluminium coils were made and fitted by a less experienced operative in less than 2 working days. However, it is noted that, compared to the use of bobbin wound coils, compression would add an additional process step.

C. Coil Termination

One of the concerns associated with the use of aluminium conductors is how to achieve a low resistance and high reliability joint. Direct soldering of aluminium to copper is not possible and therefore generally a crimped joint is used. However aluminium's tendency to form an insulating oxide layer that raises concerns about the long term reliability of anything but the most airtight bond. This is of particular concern for an aerospace application where reliability is essential, ruling out the use of crimped connections in this case.

As a result, after a survey of the numerous available options, the process of cold pressure welding [22] was identified as a strong candidate. This process, undertaken at room temperature, mechanically forces same diameter conductors of aluminium and copper into each other. This process is reported to result in removal of impurities from the surface of each material and the formation of a molecular level bond between the two conductors.

In the prototype machine the aluminium coil stub leads were therefore cold pressure welded to copper flying leads which could then be soldered into the final winding configuration without risk to reliability.

However, in order to ensure the reliability of this connection, it was necessary to undertake two key experimental validations to confirm the bonds mechanical strength and also its thermal 'strength'; that the bond would not fail prematurely under high current loadings and before either of the parent materials.

Firstly the mechanical strength of Al to Cu joint was tested using a tensile test machine. It was found that well-made joints were stronger than the Cu parent material, with the Cu failing first. It was also found that the good preparation of joints was essential and that, in particular, it was necessary to remove a length of enamel from the joint and ensure that it was grease free prior to welding. Failure to carry out these steps would result in bond failure before the parent metals.

Secondly an electrical heating test was performed. This test had the objective of identifying whether the bonding process would result in high electrical resistance at the join which could causing excessive heating, leading to a potential failure. The tests, carried out at an RMS current more than twice motor rating, showed that the aluminium wire would fail first and repeatedly some way from the bond. It was therefore concluded that a significant contact resistance did not arise and the join was not likely to fail thermally under load.

D. Coil Thermal Performance

In regard to the thermal performance of the coil, it has been stated in [2] that the effective thermal conductivity of the winding in the slot can be calculated by evaluating (assuming homogenization of impregnation and conductor insulation);

$$\lambda_{eq} = \lambda_{air} \frac{(1 + S_{FF})\lambda_{al} + (1 - S_{FF})\lambda_{air}}{(1 - S_{FF})\lambda_{al} + (1 + S_{FF})\lambda_{air}} \quad (7)$$

Where the variables, ' λ_{air} ' is the thermal conductivity of the air and ' λ_{al} ' is the thermal conductivity of the aluminium. If a further comparison is made between the properties of aluminium and copper, in terms of thermal conductivity:

$$\partial_k = \frac{\lambda_{Al}}{\lambda_{Cu}} \cong 0.593 \quad (8)$$

The assumed thermal conductivities are $387.7 \text{ Wm}^{-1}\text{K}^{-1}$, $230 \text{ Wm}^{-1}\text{K}^{-1}$ and $0.024 \text{ Wm}^{-1}\text{K}^{-1}$ for copper, aluminium and air respectively. Calculated for the same fill factor, even with the decreased thermal conductivity, the winding effective thermal conductivity is only slightly lower; this is due to the dominant factors being the fill factor and the very low thermal conductivity of air. However, taking into account the increased fill factor, the equivalent thermal conductivity of the compressed aluminium winding is found to be a factor of 2.65 greater than that of the low fill factor copper winding. The amount of air between conductors is significantly reduced at this fill factor leading to improved thermal properties.

In order to confirm these calculations a thermal test was undertaken on both copper and aluminium wound motors. A DC current of 14A per phase (equivalent to the motor operating at a torque of 20Nm) was injected into both machines, representing a common operating condition, and the winding temperatures monitored over time. This test resulted in the coils in the copper wound machine reaching a steady state temperature of 54degC above ambient whilst the aluminium machine's windings saw a 26% lower rise in temperature of 40degC over ambient (Fig. 7). Some of this difference may be attributed to the lower resistance of the compressed aluminium windings (see section VII), however it is also likely that the increased thermal conductivity of the compressed aluminium coil will have contributed to the lower winding temperature.

E. Coil Reliability

There was also considerable concern about the impact of compression on the integrity and longevity of the winding lamination.

In order to confirm the integrity of the coil a number of tests were undertaken, both before and after coil assembly with the prototype motor. Standard high voltage breakdown tests were undertaken to identify shorts between coils and the motor core as well as between adjacent coils. High voltage surge tests were also undertaken on all coils, using specially developed hardware, to confirm winding inductance and therefore that no turn to turn shorts were present. These were

then further confirmed through use of a commercially available surge tester which tested the fully assembled machines at voltages of up to 2.5kV.

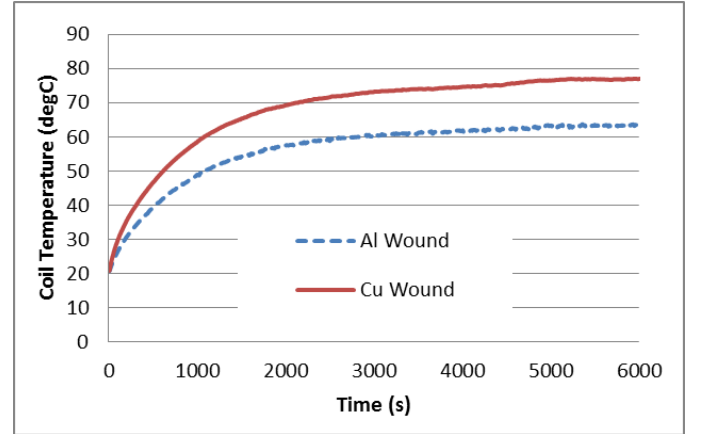

Fig. 7. Motor coil temperature versus time for Copper and compressed Aluminium stator coils under the same test conditions (14A_{rms} per phase, equivalent to 20Nm motor torque). Ambient temperature is 22°C.

Whilst these tests did find faults, these were not associated with the compression of the coils but instead due to damage to the slot liner between coil and coreback which had been caused during the fitting of the keyed tooth. Where these manufacturing failures were found it was a fast and straightforward task to repair; taking no more than 10 minutes to remove the tooth and coil, change the coil and then reassemble.

Whether there is any impact on the durability of motor windings has yet to be conclusively proven, however indications from the testing of this machine and others previously manufactured with compressed copper windings have been positive. Further work is planned in this area.

VII. PROTOTYPE MOTOR VALIDATION

Two magnetically identical motors were constructed, one using compressed aluminium windings and the keyed tooth stator and the other utilizing standard copper windings and a conventional stator. These motors are shown in Fig. 1 and Fig. 8 respectively.

Motor phase resistance was measured with the aluminium coils having, due to its very high fill factor, lower resistance than that for the conventional machine with phase resistance at 89mΩ (99% of the predicted resistance in Table I) compared to 107mΩ (107% of the predicted resistance) for the conventional machine (both at 20degC).

The two constructed motors were weighed, with the compressed winding machine being found to have a mass of 6.28kg whereas the copper machines mass was 620g higher at 6.90kg, with the mass savings being attributable to the use of aluminium coils. However, this delta is lower than the 840g predicted in Table I.

In order to identify the cause of these differences from prediction, a standalone, compressed aluminium coils was weighed and found to have a mass of 27.4g, within 1% of the predicted mass of 27g. It was not possible to weigh a fully representative copper coils without removing it from the machine, however the difference between the stator masses

would lead to the conclusion that each copper coil had a mass some 17.2g greater than each aluminium coil at 44.6g.

Analysis was undertaken which showed that this result (lower mass and increased resistance) would only be possible if the copper wire had a diameter of circa 1.01mm, lower than the 1.06 specified and outside the ± 0.011 allowable tolerance. Measurements were undertaken on the source wire and it was confirmed to meet the specification for a 1.06 conductor. As a result it is believed that the process of winding the motor to achieve the 43% fill factor, which required significant tensile forces to be applied to the conductors, led to the copper wire becoming stretched and its diameter therefore reduced. This assumption has subsequently been experimentally validated by applying similar forces to new lengths of copper wire.

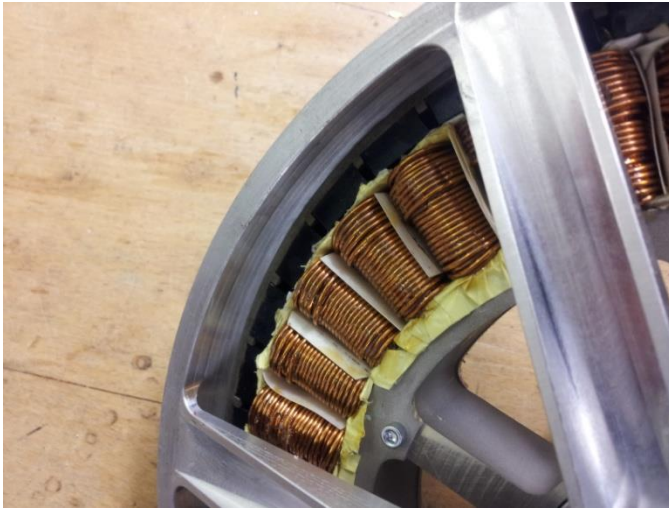

Fig. 8. Front view of the copper wound prototype motor.

A number of comparative tests were then undertaken to confirm that the motors performed consistently magnetically as well as to compare losses.

To test the magnetic performance of the two machines firstly the back EMF was measured and both machines were found to be within 1% of each other, with each having back EMF constants of about 7.7rpm/V.

A test was then also undertaken to assess motor torque versus RMS Phase current, i.e. the torque per ampere constant of the machine (Fig. 9).

Here again the performance of the two machines was extremely consistent. These tests therefore demonstrated the effectiveness of the keyed tooth stator design in allowing a separable tooth without impacting the stator permeability. Whilst it was thought possible that the EDM lamination cutting process would locally damage the permeability of the electrical steel near the cut edge, from these experimental results this effect appeared to be minimal.

It was possible to demonstrate that motor winding losses for the copper machine would be 30% higher than in the aluminium wound machine. This is a greater margin than would be predicted from the room temperature winding resistances; this is due to the higher winding temperatures in the copper machine, as discussed in Section V.D.

Iron losses were also measured for both machines. The method used to measure these losses was based on the

measurement of the motor wind-down time both with and without magnets fitted. The resulting speed versus time curve being used to estimate a quadratic loss function, which could then be split into its various elements. This analysis showed that no load iron loss was broadly consistent for the two machines with both generating only in the region of 10W at motor peak speed (1300rpm) at no load. Again this finding validates the use of the keyed tooth coreback design. This is perhaps a better result than might be predicted. Whilst it might be anticipated that the use of the EDM cut, keyed tooth structure could lead to short circuits between lamination layers, resulting in increased eddy current losses, the experimental results indicate that this is not a measurable effect under the test operating condition.

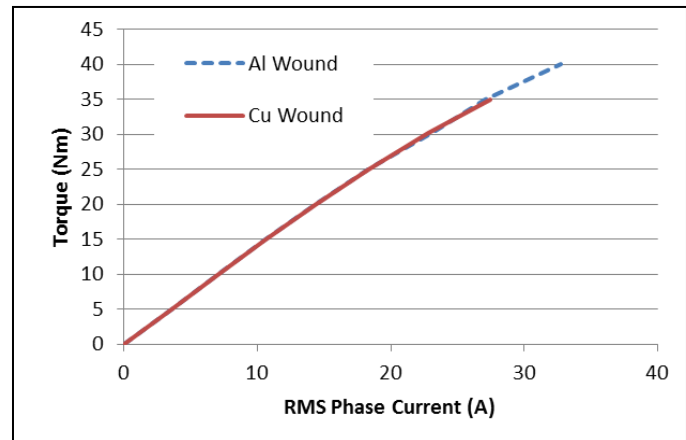

Fig. 9. Comparison between torque versus phase current for copper and aluminium wound motors.

A summary of these prototype motor experimental results are shown in Table III. The final aluminium wound motor has a mass 9% lower than the copper wound machine, a smaller margin than predicted; however this is offset by a higher than expected difference between the winding resistance of the copper and aluminium wound machines, with the aluminium machine having 17% lower resistance. The phase inductance between copper and aluminium wound machines is within 3%, with the inductance predicted for both machines from 3D finite element modelling, 727 μ H (see Table II) also within this range. This also supports the finding that the keyed tooth system has minimal impact on the permeability of the overall stator assembly.

TABLE III
PERFORMANCE OF COPPER AND ALUMINIUM WOUND PROTOTYPES

Parameter	Cu Wound	Al Wound
Coil Mass	44.6g	27.4g
Motor Mass	6.90kg	6.28kg
Phase Resistance (20°C)	107m Ω	89m Ω
Phase Inductance	716 μ H	735 μ H
Winding Fill Factor	41%	75%

VIII. CONCLUSIONS

It is possible to use aluminium windings to facilitate mass reduction in electrical machines whilst maintaining electromagnetic performance, increasing thermal performance and reducing cost.

It has been shown that the compressed aluminium winding has a weight advantage for the same loss, better thermal properties with the added benefit of up to an 85% cost reduction for the winding material (when compared to hand copper windings with fill factors of up to 45%). This makes aluminium windings potentially a more weight, cost and thermally-efficient solution provided high fill factors can be achieved. Improvements may also be possible when contrasted with higher fill factor copper coils (for example bobbin wound or compressed copper coils) however these are likely to be less marked as motor volume with aluminium windings may need to be greater to achieve the same winding loss.

For relatively low volume manufacture it is also possible to reduce manufacturing time at the expense of some additional tooling complexity. The recyclability of the machine at end of life is also increased by the elimination of copper as a contaminant in the steel recycling process.

Experimentally determined results from two prototype machines, one with compressed aluminium windings at 75% fill factor and a comparison machine with copper windings at 41% fill factor have shown it possible to build machines using this technology. These machines have used a 'keyed tooth' stator coreback assembly design which has been shown to allow fitting of coils without impact on the motors magnetic or loss characteristics.

IX. REFERENCES

- [1] Dymond, J.H. and Findlay, R.D., "Some commentary on the choice of rotor bar material for induction motors," *Energy Conversion, IEEE Transactions on*, vol. 10, pp. 425-430, 1995.
- [2] Poloujadoff, M., Mipo, J.C., *et al.*, "Some economical comparisons between aluminium and copper squirrel cages," *Energy Conversion, IEEE Transactions on*, vol. 10, pp. 415-418, 1995.
- [3] Yanniello, B., "Aluminum — The Other Conductor," *Eaton Electrical Inc.*, 2006.
- [4] Larry Pryor, R.S., Bill Brownell, "A Comparison of Aluminum vs. Copper as Used in Electrical Equipment," *GE Consumer & Industrial*, 2008.
- [5] Exchange, L.M. (2013, 15th February). *Settlement prices*. Available: <http://www.lme.com/home.asp>
- [6] Björn, K. and Jan-Ove, J., "Recycling of electrical motors by automatic disassembly," *Measurement Science and Technology*, vol. 11, p. 350, 2000.
- [7] *End of Life Vehicles*. The European Parliament and the Council of the European Union 2000/53/EC, 2000.
- [8] Aronstein, J., "Reducing the Fire Hazard in Aluminium Wired Homes," presented at the Electrical Safety Conference - Electrical Fires, University of Wisconsin, 1982.
- [9] Amos, J. (2010, 16th July) Zephyr solar plane flies 7 days non-stop. *BBC News*. Available: <http://www.bbc.co.uk/news/science-environment-10664362>
- [10] Anon. (2012, 6th June) Giant solar plane completes Spain-Morocco flight. *BBC News*. Available: <http://www.bbc.co.uk/news/science-environment-18330009>
- [11] Mecrow, B.C., Bennett, J.W., *et al.*, "Drive Topologies for Solar-Powered Aircraft," *Industrial Electronics, IEEE Transactions on*, vol. 57, pp. 457-464, 2010.
- [12] Czyzewski, A. (2011, 9th March) Collaboration set to design motors for giant solar aircraft. *The Engineer*. Available: <http://www.theengineer.co.uk/aerospace/news/collaboration-set-to-design-motors-for-giant-solar-aircraft/1007723.article>
- [13] Jack, A.G., Mecrow, B.C., *et al.*, "Permanent magnet machines with powdered iron cores and pre-pressed windings," in *Industry Applications Conference, 1999. Thirty-Fourth IAS Annual*

- [14] Wrobel, R. and Mellor, P.H., "Design Considerations of a Direct Drive Brushless Machine With Concentrated Windings," *Energy Conversion, IEEE Transactions on*, vol. 23, pp. 1-8, 2008.
- [15] Wrobel, R., Mellor, P.H., *et al.*, "Thermal Performance of an Open-Slot Modular-Wound Machine With External Rotor," *Energy Conversion, IEEE Transactions on*, vol. 25, pp. 403-411, 2010.
- [16] John Foulsham, R.K., "Coil Tooth Assembly," US Patent Application US2013/0200746 A1, 2013.
- [17] Liao, G., "Securing stator poles in yokes," UK Patent Application GB2396750 A, 2003.
- [18] Hsu, J., "High Slot Utilization Systems for Electric Machines," US Patent US7550892 B2, 2009.
- [19] Vellmer, R., "Electrical Machine," US Patent Application US2002/0175587 A1, 2001.
- [20] Yabumoto, Wakisaka, *et al.*, "Nippon Steel Technical Report No 88," 2003.
- [21] Pulnikov, Permiakov, *et al.*, "Measuring setup for the investigation of the influence of mechanical stresses on magnetic properties of electrical steel," *Journal of Magnetism and Magnetic Materials*, vol. 254-255, pp. 94-96, 2003.
- [22] Sowter, "Cold Pressure Welding," US Patent 2522408, 1950.



James D. Widmer received the M.Eng. degree in electrical and electronic engineering from the University of Bristol, U.K., in 1998. He is currently working toward the Ph.D. degree in electrical machine design in the School of Electrical and Electronic Engineering, Newcastle University, Newcastle upon Tyne, U.K. He joined Newcastle University in 2009 from a senior post in the aerospace industry. He is responsible for the "Centre for Advanced Electrical Drives," Newcastle University which works with industry partners to convert academic research into

world-class products. His research interests include high-efficiency permanent magnet machines and rare-earth magnet-free motor topologies.



Christopher M. Spargo received the BEng (Hons) degree in Electrical and Electronic Engineering from the University of Newcastle upon Tyne, Newcastle upon Tyne, U.K. in 2011. He is currently pursuing the Ph.D. degree as part of the Power Electronics, Machines and Drives research group at the same university in the School of Electrical and Electronic Engineering. His research interests include the design, modelling and control of switched and synchronous reluctance machines, applied mathematics and electromagnetic theory. He is actively involved with the Institution of Engineering and Technology, UK.



Glynn J. Atkinson received the M.Eng. degree in electrical and electronic engineering from Newcastle University, Newcastle upon Tyne, U.K., in 2001. His Eng.D. thesis was in fault-tolerant machines for aerospace applications, focusing on high-power high-speed permanent-magnet (PM) machines. He is currently with Newcastle University, where he is a Lecturer leading research in the area of 3-D machine topologies using soft magnetic composites and into PM machine topologies for use in traction applications.



Barrie C. Mecrow received the Ph.D. degree from the University of Newcastle upon Tyne, Newcastle upon Tyne, U.K.. He commenced his career as a Turbogenerator Design Engineer with NEI Parsons, Newcastle upon Tyne, U.K. He became a Lecturer in 1987 and a Professor in 1998 with Newcastle University, Newcastle upon Tyne, U.K. He is the Head of the School of Electrical and Electronic Engineering, Newcastle University, where he is also a Professor of electrical power engineering. His research interests

include fault-tolerant drives, high-performance permanent-magnet machines, and novel switched reluctance drives.