

**SPECIAL FEATURE:  
TUTORIAL**

# **Solid-phase microextraction: a powerful sample preparation tool prior to mass spectrometric analysis**

**György Vas<sup>1\*</sup> and Károly Vékey<sup>2</sup>**

<sup>1</sup> Department of Biomedical Mass Spectrometry, University of Antwerp, Universiteitsplein 1, B-2610 Wilrijk, Belgium

<sup>2</sup> Chemical Research Center for Chemistry of the Hungarian Academy of Sciences, Pusztaszeri u. 59–67, H-1067 Budapest, Hungary

Received 11 November 2003; Accepted 6 January 2004

Sample preparation is an essential step in analysis, greatly influencing the reliability and accuracy of results and the time and cost of analysis. Solid-Phase Microextraction (SPME) is a very simple and efficient, solventless sample preparation method, invented by Pawliszyn in 1989. SPME has been widely used in different fields of analytical chemistry since its first applications to environmental and food analysis and is ideally suited for coupling with mass spectrometry (MS). All steps of the conventional liquid–liquid extraction (LLE) such as extraction, concentration, (derivatization) and transfer to the chromatograph are integrated into one step and one device, considerably simplifying the sample preparation procedure. It uses a fused-silica fibre that is coated on the outside with an appropriate stationary phase. The analytes in the sample are directly extracted to the fibre coating. The SPME technique can be routinely used in combination with gas chromatography, high-performance liquid chromatography and capillary electrophoresis and places no restriction on MS. SPME reduces the time necessary for sample preparation, decreases purchase and disposal costs of solvents and can improve detection limits. The SPME technique is ideally suited for MS applications, combining a simple and efficient sample preparation with versatile and sensitive detection. This review summarizes analytical characteristics and variants of the SPME technique and its applications in combination with MS. Copyright © 2004 John Wiley & Sons, Ltd.

**KEYWORDS:** solid-phase microextraction; gas chromatography; gas chromatography/mass spectrometry; high-performance liquid chromatography; high-performance liquid chromatography/mass spectrometry; solid-phase microextraction/matrix-assisted laser desorption/ionization mass spectrometry; capillary electrophoresis/mass spectrometry; headspace; environmental chemistry; food analysis; wine; pharmaceuticals; pharmacokinetics; forensic analysis.

## **INTRODUCTION**

Present analytical and separation methods can resolve practically all kinds of complex mixtures, from gases to biological macromolecules, with detection limits down to the femtogram range. In general, the analytical method involves processes such as sampling (collection of the samples), sample preparation (separation from the matrix, concentration, fractionation and, if necessary, derivatization), separation, detection and data analysis. Surveys show that more than 80% of analysis time is spent on sample collection and sample preparation. This is necessary because in most cases analytical instruments cannot handle the sample matrices directly. The whole analytical process can be wasted if an unsuitable sample preparation method has been employed before the sample reaches the chromatograph and the analyser.<sup>1,2</sup>

Current sample preparation procedures using solvents (liquid–liquid extraction techniques (LLE)) are time-consuming, labour-intensive and multi-stage operations. Each step, especially concentration, can introduce errors and losses especially when analysing volatile compounds. Waste disposal of solvents is an additional problem, adding extra cost to the analytical procedure, extra charge for the environment and creates health hazards to the laboratory personnel. Using solid-phase extraction (SPE) cartridges or discs and microwell plates has reduced many limitations of classical LLE methods. SPE needs less solvent but it is a time-consuming multi-step process and often requires a concentration step, which may result in a loss of volatile components. Long sample preparation times are obviously disadvantageous and multi-step procedures are prone to loss of analytes. Adsorption of analytes on the walls of extraction devices can occur and trace impurities in the extraction solvent can simultaneously become concentrated. Note that even though the volume of organic solvents needed for SPE

\*Correspondence to: György Vas, Department of Biomedical Mass Spectrometry, University of Antwerp, Universiteitsplein 1, B-2610 Wilrijk, Belgium. E-mail: gyvas70@hotmail.com

is much less than that for LLE, it is still significant. Evaporation of the eluate is more time consuming in SPE than in LLE because protic solvents are mainly used (e.g. methanol), which usually have lower vapour pressure than that of the apolar solvents mainly used for LLE. In addition, clotting, channelling and percolation are typical problems of SPE encountered in everyday laboratory work. LLE and SPE are always performed off-line, but automation is nevertheless complex. Automated systems are available, but these did not lead to a breakthrough in the economics of the sample preparation.

A recent and very successful new approach to sample preparation is solid-phase microextraction (SPME). It was invented by Pawliszyn and co-workers<sup>3,4</sup> in 1989 in an attempt to redress limitations inherent in SPE and LLE. SPME integrates sampling, extraction, concentration and sample introduction into a single solvent-free step. Analytes in the sample are directly extracted and concentrated to the extraction fibre. The method saves preparation time and disposal costs and can improve detection limits.<sup>5</sup> It has been routinely used in combination with gas chromatography (GC) and GC/mass spectrometry (GC/MS) and successfully applied to a wide variety of compounds, especially for the extraction of volatile and semi-volatile organic compounds from environmental, biological and food samples. SPME was also introduced for direct coupling with high-performance liquid chromatography (HPLC) and HPLC-MS in order to analyse weakly volatile or thermally labile compounds not amenable to GC or GC/MS. The SPME/HPLC interface equipped with a special desorption chamber is utilized for solvent desorption prior to liquid chromatographic separation instead of thermal desorption in the injection port of the GC system. A new SPME/HPLC system known as in-tube SPMS was recently developed using an open-tubular fused-silica capillary column as the SPMS device instead of the SPME fibre for use in HPLC. In-tube SPME is suitable for automation, which not only shortens analysis times but often provides accuracy and precision relative to manual techniques. The main advantage of SPME is good analytical performance combined with simplicity and low cost. SPME produces relatively clean and concentrated extracts, and is ideal for MS applications.

The significance of SPME, and its nearly ideal combination with MS, has rapidly been recognised, illustrated by the nearly exponentially increasing number of publications (Fig. 1). The bars represent the number of articles published related to SPME and those related to combined SPME/MS, based on searching the *Science Citation Index* database.<sup>6</sup> The present review consists of two main sections. In the first, general aspects of SPME are described with some technical hints. In the second, SPME/MS applications are reviewed. The details of SPME and its application have also been summarized in books<sup>7-9</sup> and well-documented reviews.<sup>5,10-13</sup>

## SPME BASICS

The concept of SPME may have been derived from the idea of an immersed GC capillary column. The SPME apparatus is a very simple device. It looks like modified

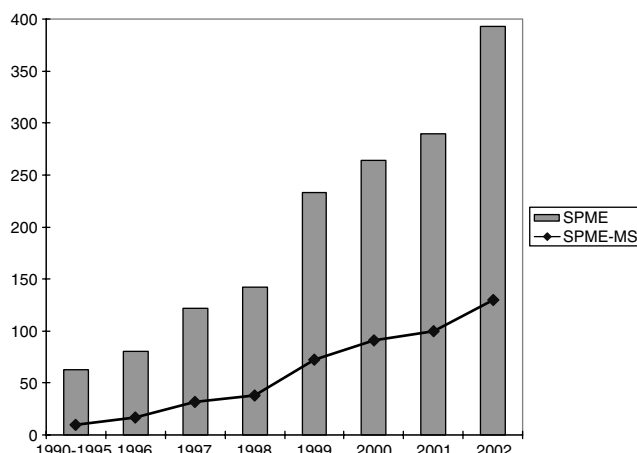

**Figure 1.** Number of published articles in recent years related to SPME and SPME/MS applications.

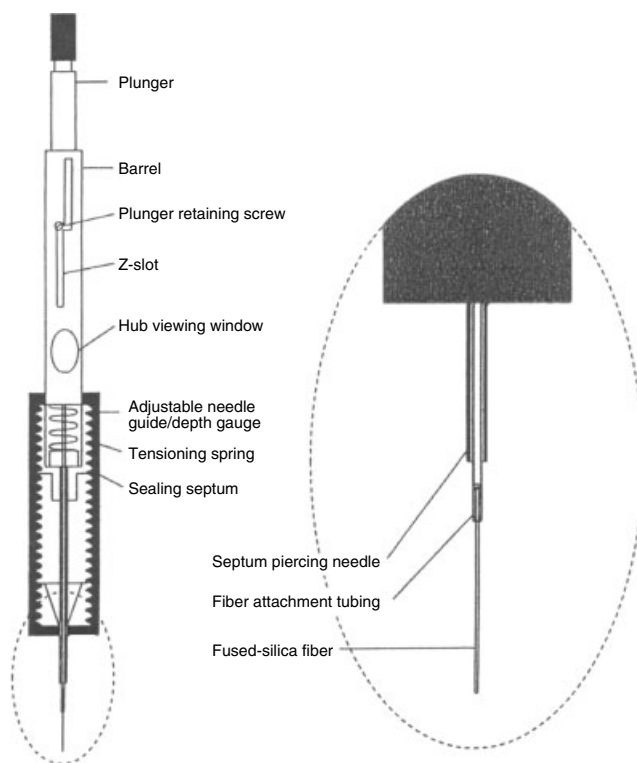

**Figure 2.** Schematic diagram of a commercial SPME device (reproduced with permission of Sigma-Aldrich).

syringe (Fig. 2) consisting of a fibre holder and a fibre assembly, the latter containing a 1–2 cm long retractable SPME fibre. The SPME fibre itself is a thin fused-silica optical fibre, coated with a thin polymer film (such as polydimethylsiloxane (PDMS)), conventionally used as a coating material in chromatography.

There are two typical SPME applications, sampling gases (headspace (HS)) or sampling solutions. In either case the SPME needle is inserted into the appropriate position (e.g. through a septum into the headspace), the needle protecting the fibre is retracted and the fibre is exposed to the environment. The polymer coating acts like a sponge, concentrating the analytes by absorption/adsorption processes. Extraction is based on a similar principle to chromatography, based

on gas–liquid or liquid–liquid partitioning.<sup>12</sup> Kinetics of the SPME extraction process depend on a number of parameters (e.g. film thickness, agitation of the sample); sampling times are typically in the order of a few minutes.

After sampling, the fibre is retracted into the metal needle (for mechanical protection), and the next step is transfer of the analyte from the fibre into the chromatograph. Gas chromatography (GC or GC/MS) is one of the preferentially used techniques. In this case, thermal desorption of the analyte takes place in the hot GC injector. After inserting the needle into the injector, the fibre is pushed outside the metal needle. The other common option is analysis by HPLC (HPLC/MS). In this case the needle is placed into a modified Rheodyne or Valco valve. The fibre is exposed and the analytes are eluted by the mobile phase. Chromatography and detection (often by ms) take place in a conventional manner.

The choice among sampling and chromatography depends mainly on the polarity and volatility of the analytes. Volatiles are most conveniently studied by HS analysis followed by GC (GC/MS). As there is no solvent (only that absorbed by the fibre), usually splitless injection is used, and analysis is very sensitive. Polar and non-volatile samples are most often studied by direct immersion (DI) sampling (the fibre is immersed in a liquid), followed by GC or HPLC analysis, possibly by capillary electrophoresis (CE). The sampling fibres can be used multiple times, hundreds of analyses in the case of HS analysis and dozens of times in the case of immersion analysis.

## TECHNICAL ASPECTS AND ANALYTICAL PERFORMANCE

### Coating materials

The fibre can be used for extract gases, the HS of solid and liquid matrices or direct immersion to the liquid matrix. The fibre is coated with a thin polymeric film, which concentrates the organic analytes (or inorganic such as volatile Hg and As compounds) during absorption or adsorption from the sample matrix. The extraction principle are based on the general rules of different equilibrium<sup>12</sup> such as gas–liquid (HS) or liquid–liquid (DI), because of the physicochemical properties of most often used PDMS (liquid polymer) or gas–solid (HS) for Carboxene fibre.<sup>12</sup> The extraction kinetics are strongly influenced by different factors (geometry, sample size, fibre parameters, etc.). It is concluded that the time of extraction is increased with increased fibre thickness and lower diffusion coefficients of the analyte molecule in the sample.<sup>12</sup> The time of extraction (until equilibrium) may be decreased with use of any type of agitation method (stirring, ultrasonics, etc.) and in the case of perfect agitation, the extraction time depends only on the geometry of the fibre and the analyte diffusion coefficients in the fibre. Probably the most important feature determining the analytical performance of SPME is the type and thickness of the coating material. Table 1 lists the most common commercially available polymer coatings. Stationary phases are immobilized by non-bonding, partial cross-linking or high cross-linking. Non-bonded phases are stable with some

water-miscible organic solvents (up to 20% organic content), but slight swelling may occur when used with non-polar solvents. Bonded phases are compatible with the majority of organic solvents except for some non-polar solvents (hexane, dichloromethane). Partially cross-linked phases are stable in most water-miscible solvents. Highly cross-linked phases are equivalent to partially cross-linked phases, except that some bonding to the core has occurred.

The most common coating material is PDMS, as mentioned above. Both PDMS and PA phases (for abbreviations see Table 1) extract samples via the absorption of analytes, which dissolve and diffuse into the coating material. The remaining types (Carbowax–DVB, Carbowax–TPR, PDMS–Carboxen and PDMS–DVB) are mixed coatings and extract via adsorption of analytes staying on the surface (as a monolayer) of the fibre.<sup>14</sup> The PDMS–Carboxen coating is a special case comprising a mixed carbon (Carboxen 1006 adsorbent with  $\sim 1000 \text{ m}^2 \text{ g}^{-1}$  surface area) phase with small micropores. As two different physicochemical mechanisms operate the mathematical theory underpinning the extraction processes needs to be modified accordingly.<sup>15</sup> The type of fibre used affects the selectivity of extraction (in general, polar fibres are used for polar analytes and non-polar fibres for non-polar analytes as with conventional GC stationary phases). Some phases have a different thickness (PDMS 7, 30 and 100  $\mu\text{m}$ ) and this affects both the equilibrium time and sensitivity of the method.

The use of a thicker fibre requires a longer extraction time but the recoveries are generally higher. The time of extraction is independent of the concentration of analyte in the sample and the relative number of molecules extracted at a distinct time is also independent of the concentration of analyte.<sup>12</sup> Usually the thinnest acceptable film is employed to reduce extraction times. Before using a new fibre (or after long-term storage for a used fibre) conditioning is necessary, applying the maximum desorption temperature for 0.5–4 h prior to GC/MS applications. High-purity carrier gases are essential for conditioning, because some extraction phases can easily become oxidized by trace levels of oxygen. The new fibres can be conditioned before LC/MS or CE/MS applications by stirring of them in methanol for tens of minutes. Fibres can be reused several times (20–150 or more) depending on the sample matrix.<sup>16</sup>

### Extraction procedure

The coated fibre is immersed directly in the sample or the HS of the sample, where the analytes are concentrated. After equilibrium has been reached (from a few minutes to several hours depending on the properties of the analytes measured) or after a defined time the fibre is withdrawn and transferred either to a GC injection port or a modified Rheodyne or Valco HPLC valve. The fibre is exposed and the analyte is desorbed either thermally in the hot GC injector port or (in the case of HPLC) eluted by the mobile phase and subsequently chromatographed in a conventional manner. With very complex matrices such as sludges, biological fluids and food products or using solid samples, the SPME technique is mainly applied for the extraction of analytes from the HS of the sample. In both sampling (immersion or

**Table 1.** Summary of commercially available SPME fibres

Fibre coating	Film thickness (µm)	Polarity	Coating method	Maximum operating temperature (°C)	Technique	Compounds to be analysed
Polydimethylsiloxane (PDMS)	100	Non-polar	Non-bonded	280	GC/HPLC	Volatiles
PDMS	30	Non-polar	Non-bonded	280	GC/HPLC	Non-polar semivolatiles
PDMS	7	Non-polar	Bonded	340	GC/HPLC	Medium- to non-polar semivolatiles
PDMS–divinylbenzene (DVB)	65	Bipolar	Cross-linked	270	GC	Polar volatiles
PDMS–DVB	60	Bipolar	Cross-linked	270	HPLC	General purpose
PDMS–DVB <sup>a</sup>	65	Bipolar	Cross-linked	270	GC	Polar volatiles
Polyacrylate (PA)	85	Polar	Cross-linked	320	GC/HPLC	Polar semivolatiles (phenols)
Carboxen–PDMS	75	Bipolar	Cross-linked	320	GC	Gases and volatiles
Carboxen–PDMS <sup>a</sup>	85	Bipolar	Cross-linked	320	GC	Gases and volatiles
Carbowax–DVB	65	Polar	Cross-linked	265	GC	Polar analytes (alcohols)
Carbowax–DVB <sup>a</sup>	70	Polar	Cross-linked	265	GC	Polar analytes (alcohols)
Carbowax-templated resin (TPR)	50	Polar	Cross-linked	240	HPLC	Surfactants
DVB–PDMS–Carboxen <sup>a</sup>	50/30	Bipolar	Cross-linked	270	GC	Odours and flavours

<sup>a</sup> Stableflex type is on a 2 cm length fibre.

HS) modes the agitation of the sample matrix (e.g. stirring, sonication) improves transport of analytes from the bulk sample phase to the vicinity of the fibre.

#### Fibre extraction

The process of sampling is illustrated in Fig. 3.<sup>5</sup> The sample placed in a vial, which is sealed with a septum-type cap or with a Mininert valve. The fibre should be cleaned (and if necessary conditioned) before analysing any sample in order to remove contaminants which give a high background in the chromatogram. Cleaning can be done by inserting the fibre in an auxiliary injection port or a syringe cleaner. When the SPME needle pierces the septum and the fibre is extended through the needle into the sample, partitioning between the sample matrix and the stationary phase takes place. This may occur in two different ways: headspace (HS-SPME) or direct immersion (DI-SPME). In HS-SPME, the fibre is exposed in the vapour phase above a gaseous, liquid or solid sample. In DI-SPME, the fibre is directly immersed in liquid samples. Agitation of the sample is often carried out with a small stirring bar to decrease the time necessary for equilibration. After a suitable extraction time the fibre is withdrawn into the needle, the needle is removed from the septum (or valve) and is then inserted directly into the hot injection port of the GC system or the desorption chamber of the SPME/HPLC interface. HS- and DI-SPME techniques can be used in combination with any with any GC, GC/MS or HPLC and HPLC/MS systems. The desorption of analytes from the fibre coating is performed by heating the fibre in the hot injection port of the GC or GC/MS system or by loading solvent into the desorption chamber of the SPME/HPLC interface and then the analytes are transferred directly to the separation column for analysis as shown in Fig. 3.<sup>5</sup>

Extraction efficiency and the time necessary to reach equilibrium can be influenced in a number of ways. When

extracting semivolatile compounds from an aqueous matrix, the fibre is usually immersed directly in the sample (DI-SPME). If the sample is agitated with a magnetic stirrer or ultrasonically, then equilibrium is reached faster. Dedicated apparatus for this purpose is available (Supelco, Varian, CTC-PAL). The time necessary for equilibrium is a function of the analyte and conditions used (fibre polymer and thickness, temperature, etc.). HS sampling is generally used for more volatile compounds and has the advantage of faster extraction times and the selectivity is often improved. Extraction efficiency can be improved by modifying the matrix, target analytes and the SPME device itself. To maintain precision and repeatability (reproducibility), these conditions and others such as extraction temperature, sample agitation, sample pH and ionic strength, sample volume, extraction and desorption conditions must be kept constant.<sup>13,17</sup> The effects of temperature, pH, change of activity coefficient by salting-out are similar to those encountered in conventional HS sampling.<sup>18</sup> In addition, saturation with salt can help normalize random salt concentrations found in biological matrices. To prevent losses of trace and polar analytes, deactivation of glassware and vials before use is recommended (Sylon CT).<sup>9,19</sup> For GC desorption, a narrow-bore (0.75 mm i.d.) unpacked injection liner is required to ensure a high linear gas flow, reduce desorption time and prevent peak broadening. Because no solvent is used for sample preparation, injections are carried out in the splitless mode to ensure complete transfer of analyte and to increase sensitivity. Both time and temperature used for the desorption influence recovery and these need to be optimized. The position of the fibre inside the injector is important as temperature varies along its length. The GC septa can easily become damaged with the large (24 gauge) SPME guide needles. To avoid septum coring, pre-drilled high-temperature GC septa can be used or a Merlin microseal septumless system (with a 23

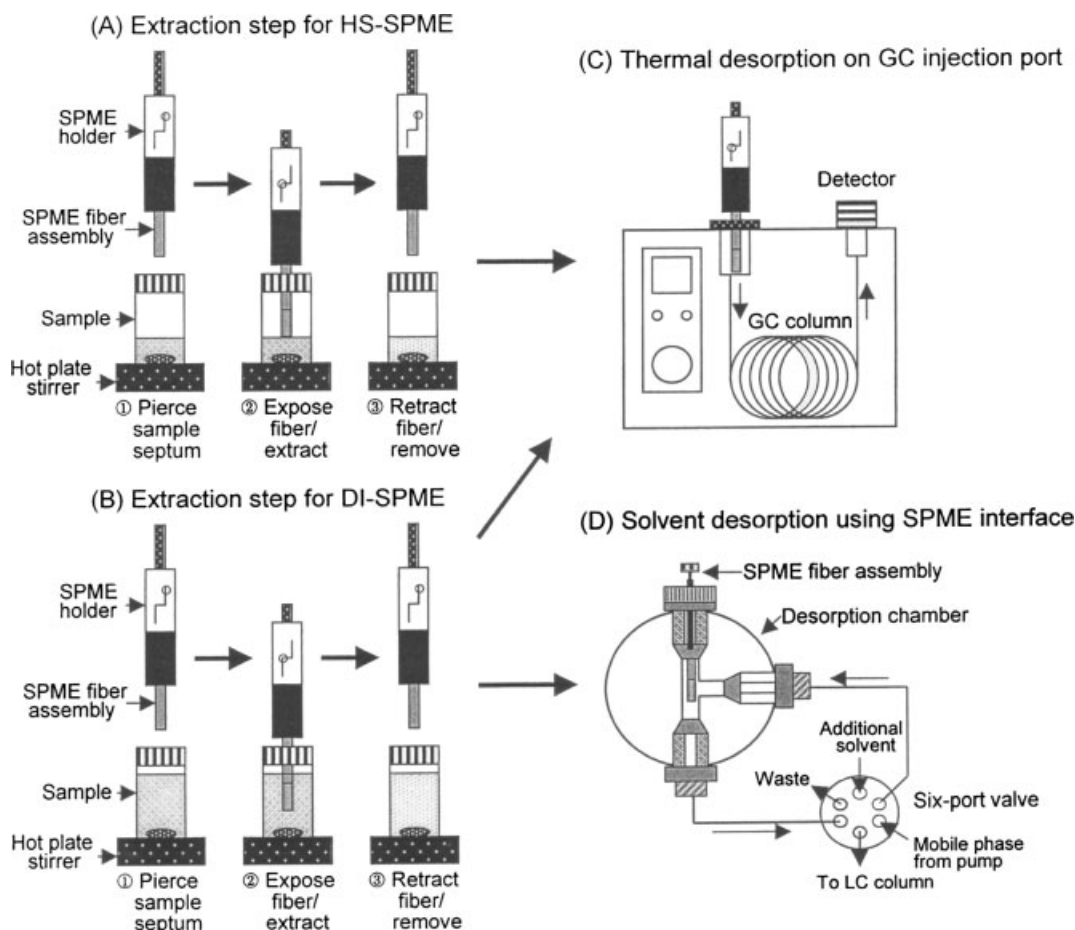

**Figure 3.** SPME procedure for GC and for LC. Reprinted from *Journal of Chromatography A*, **880**, Kataoka H, Lord LH, Pawliszyn J, Applications of solid-phase microextraction in food analysis, page 40, Fig. 3, Copyright (2000), with permission of Elsevier.

gauge SPME needle) or JADE valve is recommended. These options help to prevent contamination of the liner with septa material. To avoid sample carryover, the fibres may also be desorbed for a second time between the analytical runs in a separate GC injector.

The HPLC interface consists of a six-port injection valve and a special desorption chamber, because the fibre requires solvent desorption of analytes prior to HPLC or HPLC/MS analysis. The desorption chamber is placed in the position of the injection loop in Fig. 4. After sample extraction, the fibre is inserted in the desorption chamber in the 'load' position under ambient pressure. When the injector is changed to the 'inject' position, the mobile phase contacts the fibre and desorbs the analytes and delivers them to the HPLC column (Fig. 3(B)). The fibre SPME/HPLC method also has the advantage of eliminating the solvent front peak from the chromatogram. Unfortunately, peak broadening is sometimes observed because analytes can be slow to desorb from the fibre.

Fibre extraction, discussed above, is the most widespread SPME technique. Two important new variants have recently been developed, in-tube SPME and stir bar sorptive extraction (SBSE). High-throughput applications and automated instrumentation are becoming more and more important. In-tube SPME has been developed mainly to extend SPME in this direction. SBSE, on the other hand, has

been developed to increase the sensitivity of immersion analysis.

#### *In-tube extraction*

In-tube SPME using an open-tubular capillary column as the SPME device was developed for coupling with HPLC or HPLC/MS. It is suitable for automation and can continuously perform extraction, desorption and injection using a standard autosampler. With the in-tube SPME technique, organic compounds in aqueous samples are directly extracted from the sample into the internally coated stationary phase of a capillary column and then desorbed by introducing a moving stream of mobile phase or static desorption solvent when the analytes are more strongly adsorbed to the capillary coating. A schematic diagram of the automated HPLC/MS system is illustrated in Fig. 5.<sup>5</sup>

The extraction capillaries have coatings similar to commercially available SPME fibres (Table 1). The capillary column used for the extraction is placed between the injection loop and the injection needle of the HPLC autosampler. While the injection syringe repeatedly draws and ejects samples from the vial under computer control, the analytes partition from the sample matrix into the stationary phase until equilibrium is reached. Subsequently, the extracted analytes are directly desorbed from the capillary coating by mobile phase flow or by aspirating a desorption solvent. The

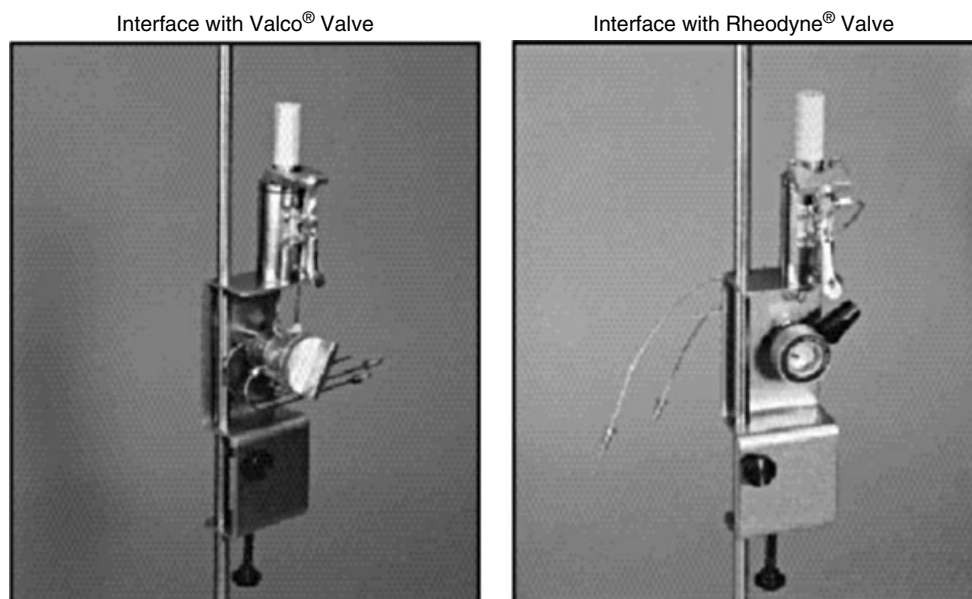

**Figure 4.** Commercially available LC interfaces from Supelco. Reproduced from Supelco Product Specification Sheet T496049, with permission of Sigma-Aldrich.

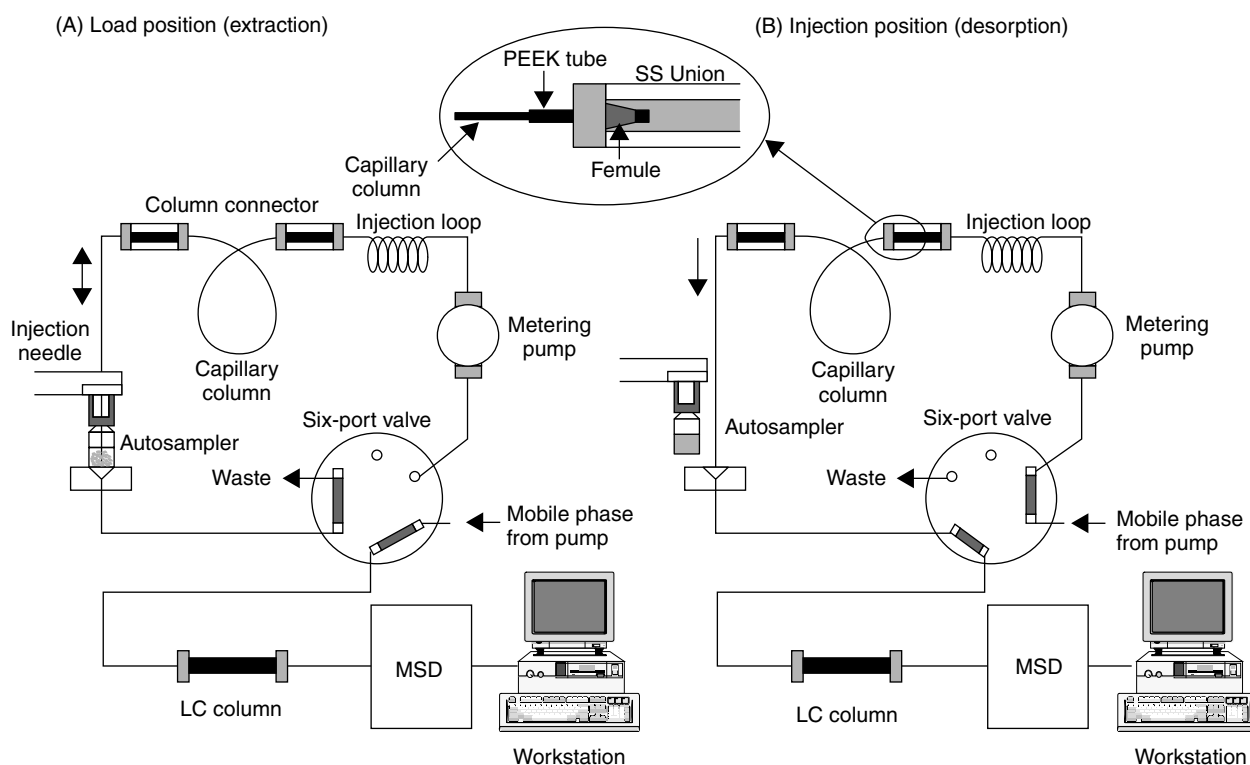

**Figure 5.** Automated in-tube extraction system. Reprinted from *Journal of Chromatography A*, **880**, Kataoka H, Lord LH, Pawliszyn J, Applications of solid-phase microextraction in food analysis, page 41, Fig. 4, Copyright (2000), with permission of Elsevier.

desorbed analytes are transported to the HPLC column for separation and then detected with UV or MS.

Although the basic concepts of fibre and in-tube SPME methods are similar, there is a significant difference between these methods. Extraction of analytes is performed on the outer surface of the fibre for fibre SPME and on the inner surface of the capillary column for in-tube SPME. With the in-tube SPME method it is necessary to prevent plugging of the extraction capillary, and therefore the particulates must

be removed from samples by filtration before extraction. This is in contrast to fibre SPME where it is not necessary to remove particles before extraction because they can be removed by washing the fibre with water before insertion into the desorption chamber of the SPME/HPLC interface. However, the fibres should be carefully handled because they are fragile (made from quartz), can easily break and the fibre coating can be damaged during insertion and agitation. Furthermore, high molecular mass compounds

such as polyphenols<sup>17</sup> or proteins can adsorb irreversibly on the fibre, thus changing properties of the stationary phase. Another significant difference between in-tube SPME and manual fibre SPME/HPLC is the possible decoupling of desorption and injection with the in-tube SPME method. In the fibre SPME method, analytes are desorbed during injection as the mobile phase passes over the fibre. On the other hand, in the in-tube SPME method analytes are desorbed by mobile phase or aspirating a desorption solvent from a second vial, and then transferred to the HPLC column by mobile phase flow. With the in-tube SPME method, peak broadening is comparatively small because analytes are completely desorbed before injection. The carryover effect for these 'flushing'-type desorption solutions is 0.1% or less,<sup>20,21</sup> which is excellent for most analytical applications.

The commercially available open-tubular GC columns can be used as extraction capillaries for in-tube SPME for extraction, but some unique phases and technical solutions have also been reported.<sup>22–27</sup> Note in particular new coatings such as ADS, MIP and PPY, discussed in detail recently.<sup>26</sup> To obtain higher extraction efficiency and extend the method to microscale applications, different techniques such as wire-in-tube<sup>28,29</sup> or fibre-in-tube<sup>28,30–33</sup> have also been developed. By insertion of a stainless-steel wire into the extraction capillary of in-tube SPME, the internal volume of the capillary can be significantly reduced while the surface area of the polymeric coating material remains the same. With this configuration, the internal volume and phase ratio are dramatically reduced and therefore the extraction is most effective.<sup>29</sup> The other technique, called fibre-in-tube (FIT), used several hundred fine filaments of polymeric material packed longitudinally into a short capillary of polyether ether ketone (PEEK) or polytetrafluoroethylene (PTFE). This forms the basis of the successful wire-in-tube extraction tube.<sup>29</sup> This technique is not only used to reduce the internal void volume of the extraction tube, but also the fine polymer filaments can be employed as the extraction medium. Owing to the parallel arrangement of the filaments with the outer tubing, a number of coaxial narrow channels are formed inside the capillary. It has also been demonstrated that the effective interaction of the sample solution with a number of fine fibrous extraction capillaries could enable further miniaturization as a microscale sample preconcentration device. Further downsizing of the extraction device will also allow direct coupling of the extraction process with microcolumn separation methods, but without any disadvantages such as overloaded sample injection and poor resolution during the chromatographic separations. The structure of the wire in tube and the fibre in tube shown in Fig. 6.<sup>28</sup>

#### Stir BAR sorptive extraction (SBSE)

The sensitivity of SPME is sufficient for most applications, but occasionally it is limited by the small amount of coating material on the needle (typically less than 0.5  $\mu\text{l}$ ), which results in low extraction efficiency. This demands the use of very sensitive and selective detectors. To improve the extraction efficiencies and the amount of extracted analytes, the volume of the extraction phase can be increased. For this purpose, a novel approach has been introduced, using a

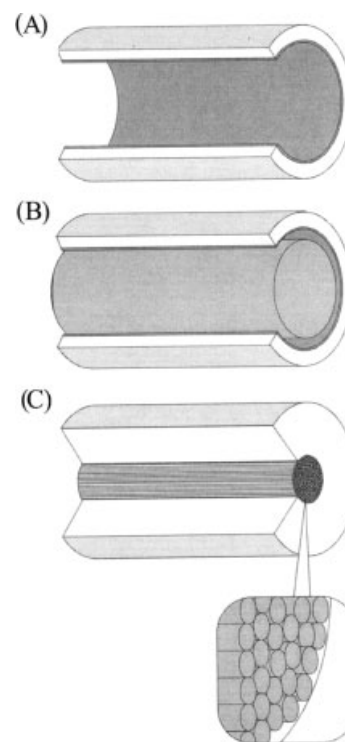

**Figure 6.** Schematic drawing of three different types of in-tube extraction capillaries: conventional capillary (a), wire-in-tube (b), fiber-in-tube (c). Reprinted from *Journal of Chromatography A*, **1000**, Saito Y, Jinno K, Miniaturized sample preparation combined with liquid phase separations, page 59, Fig. 4, Copyright (2003), with permission of Elsevier.

short bed packed with PDMS.<sup>34</sup> First these were prepared by removing the Teflon coating of existing Teflon bars, reducing the outer diameter of the magnet and coating the magnet with a glass tube and covering it with PDMS polymer. The packed PDMS bed contains  $\sim 300 \mu\text{l}$  of PDMS polymer which is a marked increase (about 600 times more) compared with the amount present in in-tube capillary systems (0.25–0.5  $\mu\text{l}$ ) or fibre SPME. PDMS-coated stir bars are now commercially available from Gerstel (Müllheim a/d Ruhr, Germany).

Sampling of large volumes for ultimate sensitivity can be performed in a relatively short time using a stir bar (Fig. 7).<sup>34</sup> For strongly retained compounds sampling is performed in the breakthrough mode whereas for weakly retained analytes, or in those cases where maximum sensitivity is desired, sampling is continued until all analytes are in equilibrium with the sorbent. Generally sampling times can be kept within 30 min while still yielding adequate sensitivity. Desorption is accomplished thermally for maximum sensitivity, but the analytes may also be desorbed by a liquid, e.g. on-line coupling to HPLC. For many compounds the superior performance of PDMS compared with classical adsorbents was shown, including sulfur compounds and epoxides. For gaseous samples, packed PDMS beds work very well, but for liquid (aqueous) samples, where drying after sampling is essential, the packed PDMS approach fails for highly volatile analytes. These compounds are totally lost during the drying process. After extraction, the components are desorbed by

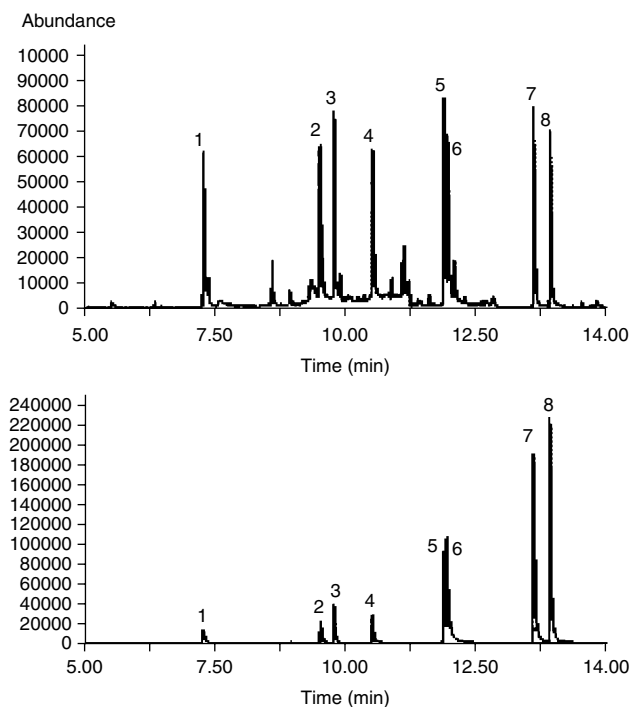

**Figure 7.** Sensitivity comparison of SPME and SBSE. Reprinted from *Journal of Microcolumn Separations*, **10**, Baltussen E, Sandra P, David F, Cramers C, Stir bar sorptive extraction, SBSE, a novel extraction technique for aqueous samples: theory and principles, page 742, Fig. 3, Copyright (1999), with permission of John Wiley & Sons, Inc. Analysis of a 60 ml water sample spiked with PAHs using SBSE (upper chromatogram) and SPME (lower chromatogram). In both cases an equilibration time of 30 min was used. In the SBSE experiment a spiking level of  $30 \text{ ng l}^{-1}$  was used whereas in the SPME experiment a  $3 \mu\text{g l}^{-1}$  level was used. Components: 1, naphthalene; 2, acenaphthylene; 3, acenaphthene; 4, fluorene; 5, phenanthrene; 6, anthracene; 7, fluoranthene; 8, pyrene.

thermal desorption. Unfortunately, the desorption requires a special autosampler (Gerstel TDSA or Perkin-Elmer Turbomatrix TD).

### Optimization of desorption

Efficient thermal desorption of the analyte in a GC injection port is dependent on the analyte volatility, the thickness of the fibre coating, injection depth, injector temperature and exposure time. A narrow-bore GC injector insert is required to ensure a high linear flow and the fibre needs to be exposed immediately after the needle is introduced into the insert. The needle exposure depth should be adjusted to place the fibre in the centre of the hot injector zone. Most split/splitless capillary injectors in modern GC instruments are suitable for direct introduction of the fibre. The liner volume affects the shape of the chromatographic peaks, for example larger volumes cause peak broadening and tailing. Split/splitless injectors should be operated in the splitless mode. Generally, the optimal desorption temperature is approximately equal to the boiling-point of the least volatile analyte. In practice, the extraction temperature should be  $10\text{--}20^\circ\text{C}$  lower than the temperature limit of the fibre. To

prevent peak broadening, the initial GC column temperature should be kept low or possibly even cooled (cryofocusing). In this way, concentration of analytes at the head of the column is achieved. The desorption time depends on the injector temperature and the linear flow-rate around the fibre.

There are two techniques for removing the analytes from the fibre in SPME/HPLC interfaces, dynamic and static desorption. In dynamic desorption, the analytes are removed from the fibre by the moving mobile phase. When the analytes are more strongly absorbed into the fibre, it can be soaked in the mobile phase or in a strong solvent for a specified time (static desorption) before injection on to the HPLC column. In both cases, rapid and complete desorption of analytes using a minimal solvent amount is important for optimizing the SPME/HPLC or SPME/HPLC/MS methods. In contrast, the 'in-tube' SPME technique (discussed above) does not need a special SPME/HPLC interface for desorption of analytes, making automation easier.

The analytes extracted on to the capillary coating can be easily desorbed by a moving stream of mobile phase or an additional desorption can be used when the analytes are more strongly adsorbed on the capillary coating. Carryover in the in-tube SPME method is lower than in the case of the fibre SPME method.

### Derivatization

Derivatization may be necessary and can be used in SPME just as in the case of LLE and SPE for chemical transformation of the analyte into a form which is more suitable for analysis.<sup>12</sup> Derivatization can increase the volatility and/or reduce the polarity of some analytes and therefore can improve extraction efficiency, selectivity and detection. Three different procedures are currently used: direct derivatization, derivatization on the SPME fibre (Fig. 10) and derivatization in the GC injection port.<sup>7</sup> *In situ* derivatization is often preferred in SPME. In this case a derivatization agent is added to the sample matrix, derivatization takes place and the SPME fibre extracts the derivatized analytes either from the solution or from the HS. For this purpose only a limited number of agents can be used because many derivatization agents are unstable in the most frequently encountered aqueous matrices. This approach has been used with phenols in water by converting them to acetates with acetic anhydride.<sup>35</sup> Trimethylxonium tetrafluoroborate has been used for formation of methyl esters from urinary organic acids,<sup>36</sup> methanolic HCl to form esters of organic acids in tobacco, and propyl chloroformate to derivatize the amino group on amphetamines in urine.<sup>13</sup> Other reagents include pentafluorobenzaldehyde for primary amines<sup>37</sup> and sodium tetraethylborate and thioglycol methylate for *in situ* derivatization of organometallics.<sup>38</sup> On-fibre derivatization (e.g. with diazomethane or with MSTFA) can be employed after the extraction procedure. Extracted compounds on the fibre are exposed (in a heated and sealed HS vial) to the derivatizing reagent in the vapour phase for a given time. This has been employed for serum steroid<sup>39</sup> and urinary hydroxyl metabolites of polycyclic aromatic hydrocarbons (PAHs).<sup>40</sup> Silylation with BSTFA (bis(trimethylsilyl)trifluoroacetamide) at  $60^\circ\text{C}$  for 45–60 min is effective for all these analytes.



Simultaneous derivatization and extraction can be carried out. Prior to extraction, the fibre is doped with reagent and on sampling the analytes are converted to derivatives that have a high affinity for the coating. This not an equilibrium process as the analytes are converted as soon as they are extracted on to the fibre for as long as the extraction process continues. Loss of reagent is minimal as it has a low vapour pressure and high affinity for the coating. Recently, *o*-(2,3,4,5,6-pentafluorobenzyl)hydroxylamine hydrochloride was used in a similar manner for monitoring formaldehyde in air.<sup>41</sup> Derivatization can be carried out on the SPME fibre in a GC injection port.<sup>19</sup> Nagasawa *et al.*<sup>42</sup> made elegant use of this approach to measure amphetamines, which after extraction were derivatized in the liner by injection of heptafluorobutyric anhydride to form amide derivatives.

### Quantitation

At the beginning of the history of SPME, the technique was mainly used for qualitative or semi-quantitative (screening) studies. Quantitation is also possible; the requirements in such a case (e.g. use of internal standards) are analogous to those used in other forms of quantitation related to sample preparation and instrumental analysis. HS-SPME involves multi-phase equilibrium processes and careful consideration must be given to the physicochemical properties of the candidates for internal standards. The fibre coating removes the compounds from the sample by absorption in the case of liquid coatings (PDMS) or adsorption in the case of solid coatings (Carboxene). Traditional sample preparation methods try to remove completely the analytes of interest from the sample, but the fibre and the in-tube SPME do not work in this way. With SPME, the amount of analyte removed by the fibre (or extraction capillary) is proportioned to the concentration of the compounds in the sample. The ability to use SPME quantitatively before reaching equilibrium permits much shorter sampling times, producing a fast economical and versatile technique. The decision as to which quantitation approach is to be selected depends on the sample matrix, its complexity and the extraction method (HS or DI) being used. Qualitatively optimization of the SPME parameters should be applied to determine the best fibre and sampling conditions to use before selecting a quantitation approach and calibrating the instrument. For simple non-complex matrices such as gases or HS of simple liquids (HS of drinking water), the simplest external calibration can be used. For complex matrices, calibration using an internal standard or standard additions is advised.<sup>43</sup> MS detection is the optimal quantitation technique as it allows isotopically labelled (<sup>2</sup>H, <sup>13</sup>C, <sup>14</sup>C) analogues to be spiked into the sample. The behaviour of these compounds closely mimics the target analytes. The reproducibility and precision can be improved with fibre SPME through careful control and monitoring of time and temperature (which should be precisely constant) during sample extraction. The extraction time is a critical parameter in the SPME sampling process. Figure 8<sup>43</sup> shows the typical relationship between extraction time and analyte absorbed on the fibre. Before the equilibrium (between the fibre and the sample), the time factor is very critical, but after

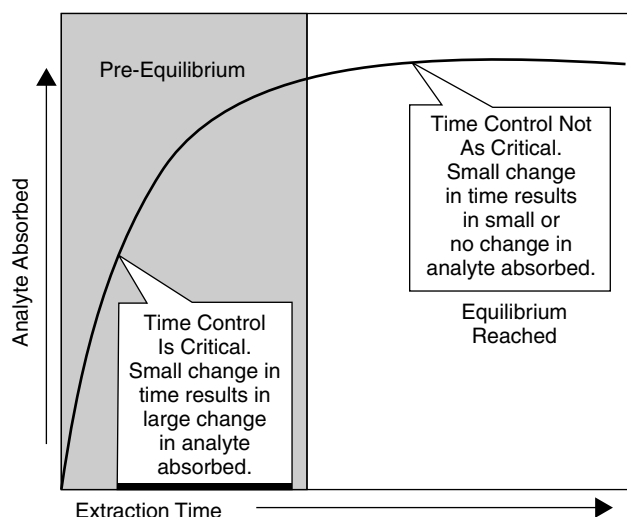

**Figure 8.** Time effect for SPME extraction (reproduced from Ref. 43, with permission of Sigma-Aldrich).

the equilibrium has been reached (typically a few minutes in HS and with agitated DI), small changes in extraction times have no critical influence on the quantitative results.<sup>43</sup>

### APPLICATION OF SPMEMS IN VARIOUS FIELDS OF ANALYTICAL CHEMISTRY

SPME is a fast, selective and relatively inexpensive sample preparation method. Extraction can also be done by an automating process. Different samples can be extracted prior to GC or LC separation. Unfortunately, the SPME extraction method has a low recovery (except SBSE), and therefore sensitive detection is essential. MS is one of the most selective and sensitive analytical methods. As shown in Fig. 1, it is used very often in combination with SPME, much more frequently than in other chromatographic applications.

#### Environmental applications

Since its invention in 1989,<sup>3</sup> there has been a rapid growth in the number of applications of SPME (Fig. 1), evidenced by the growing number of published papers. In the early developmental period the majority of applications were in environmental chemistry. Mostly organic compounds<sup>44–51</sup> have been studied, and pesticides, herbicides and other biologically active compounds in aqueous samples.<sup>52–54</sup> For analysing volatile and semivolatile compounds in solid samples such as soils sediments and sludges, HS-SPME has often been used.<sup>55</sup> So far, HS-SPME has been used to determine aromatics and PAHs in spiked sand and clay matrices,<sup>56</sup> volatile organic compounds in landfill soils,<sup>57</sup> organometallic compounds in sediments<sup>58</sup> in soil,<sup>59</sup> and in plasma samples<sup>60</sup> and inorganic mercury samples in soil.<sup>61</sup> It has also been used for the determination of odorants,<sup>62</sup> chloro- and nitrobenzenes<sup>63,64</sup> and chloro- and nitroanilines in a broad variety of soils.<sup>65</sup> SPME extraction is also can be applied for the direct determination of different components of air samples, which is analogous to the conventional HS extraction.<sup>66–69</sup> Generally, the sensitivity of the HS-SPME procedure can be improved by manipulation of the matrix (e.g. addition of acetone–water

(70:30)<sup>63</sup>) or by optimisation of the extraction conditions (e.g. fibre coating material, temperature, stirring and extraction time<sup>63,70</sup>). For instance, the effect of high temperature and water addition has been reported to be of major importance for the analysis of low-volatile analytes such as PAHs in soils.<sup>71,72</sup> Different procedures have been described for quantitative analysis of solid samples such as soils sediments and sludges by HS-SPME. Moens *et al.*<sup>58</sup> obtained good results for the analysis of organometallic compounds in a reference sediment material using a spiked water solution for calibration. Nevertheless, matrix effects due to soil characteristics, especially the organic carbon and clay contents, which can strongly adsorb the analytes, can affect the quantitative analysis of solid samples.<sup>65</sup> Therefore, calibration has frequently been performed by standard additions within the linear range of both the HS-SPME procedure and the detector.<sup>57,63–65</sup> Sarrion and co-workers used a standard additions method for the determination of chlorobenzenes in a sandy soil samples by HS-SPME/GC/MS.<sup>63,64</sup> Although HS-SPME allows the extraction of analytes from polluted matrices, avoiding contact with the sample, HS-SPME has also been used to analyse pesticides and fungicides in water,<sup>73–75</sup> alkylbenzenes, aromatic amines,<sup>76</sup> chlorophenols,<sup>77</sup> phthalates,<sup>78,79</sup> PAHs and hexachlorobenzenes in soils,<sup>70,80,81</sup> organometallics in sediments<sup>82</sup> and alkylphenol ethoxylate surfactants in sludges.<sup>83</sup> The analysis by DI-SPME is performed by immersion of the fibre in solid solution<sup>81–83</sup> or in an aqueous extract of the solid.<sup>70,80</sup> Generally, quantification is performed with using external calibration and spiked aqueous solutions, assuming that the matrix does not significantly interfere with the extraction. However, Boyd-Boland and Pawliszyn<sup>83</sup> reported that the matrix interferes with the analysis of alkylphenols in sewage sludges and suggested that the use of the standard additions method would overcome the problem. Quantitation of analytes in soil samples by DI-SPME using standard additions has not been frequently reported.

Sarrion *et al.* developed an SPME method for the determination of chlorobenzenes in soil samples.<sup>63</sup> The chlorobenzenes have been included as priority pollutants in the US Environmental Protection Agency (US EPA) and European Union (EU) lists. They found SPME to be a possible alternative to classical Soxhlet extraction. HS and direct SPME were also tested for an industrially contaminated clay soil (CRM-530, which is a candidate reference material). Chlorobenzenes were quantified by standard addition methods, which led to good reproducibility (RSD 2–10%) for both HS- and DI-SPME/GC/MS. The detection limit using SPME sample preparation and MS detection was 30–100 pg g<sup>-1</sup>. Another interesting application was reported by Müller *et al.* for the determination of aromatic amines in water samples.<sup>76</sup> Aromatic amines such as aniline and substituted derivatives are generally dangerous because of their toxicity and carcinogenicity<sup>84</sup> or else they can be converted easily into toxic *N*-nitroso compounds through reactions with nitrosylating agents in the environment. Aromatic amines have already been analysed in environmental samples using a variety of analytical techniques, e.g. GC<sup>85</sup> coupled with analogue or MS detectors, HPLC,<sup>86</sup> and CE.<sup>87</sup> They used

DI-SPME for extraction and GC/MS for detection. After optimization the analytical procedure achieved free amine detection without chemical derivatisation using a 65 µm CV-DVB fibre. The detection limit for different amines was 7–25 ng l<sup>-1</sup>, and the RSD was 4–6%.

Phenols and halogenated phenols are also in the US EPA list of priority pollutants.<sup>88</sup> The EU has also classified several phenols as priority contaminants and the 80/778/EC Directive states a maximum concentration of 500 ng l<sup>-1</sup> for total phenols in drinking water and individual concentrations should be under 100 ng l<sup>-1</sup>. Llompert *et al.* developed an HS-SPME/GC/MS method for determination of low-concentration phenolics and halogenated phenolics in water using *in situ* acetylation.<sup>89</sup> They quantified 30 phenolics in water using a 75 µm Carboxen–PDMS extraction fibre. The detection limits (1–40 ng l<sup>-1</sup> for different phenolics) is even lower than in the regulations and the RSD values of 1–12% are acceptable at that low concentration. On the other hand, Sarrion *et al.* used HS-SPME and DI-SPME for the extraction of chlorophenols from solid (soil and wood) and aqueous matrices before HPLC/MS/MS analysis.<sup>90</sup> They determined all of the chlorophenol isomers (19) simultaneously with ng g<sup>-1</sup> sensitivity using a triple-quadrupole system in the multiple reaction monitoring (MRM) mode.

Phthalic acid diesters, commonly known as phthalates, are produced all over the world in large quantities, and they have a variety of industrial uses. During the determination of phthalates, separation from the sample matrix is very important. SPME was coupled with phthalate determination by GC/MS using a 75 µm CV–DVB fibre<sup>78</sup> or 85 µm PA fibre.<sup>79</sup> They were analysed in different types of water samples (river water, mineral water and bottled water).<sup>91</sup> DI-SPME, which was used as a sample preconcentration technique, was sensitive and linear between 20 and 10 000 ng l<sup>-1</sup>. Jinno and co-workers also studied different phthalates in natural water and human urine samples using automated fibre-in-tube extraction and HPLC/MS detection. The detection limit for different phthalates were less than 1 µg l<sup>-1</sup>.

Direct and HS-SPME have been studied many times as a possible alternative to LLE for the analysis of different types of pesticides, insecticides, herbicides and fungicides. After extraction of different compounds, the compounds can be measured directly or after derivatization as is the case with haloacetic acids.<sup>52,92</sup> The separation of the extracted compounds can be done by using GC or HPLC systems. After the separation, mainly MS detection was recommended. The main advantages of using MS are the sensitivity and selectivity. The majority of methods are based on GC/MS separation and detection<sup>93,94</sup> but nowadays HPLC/MS methods have become more and more popular.<sup>95</sup> Extraction of these compounds from different matrices has been reported such as from water,<sup>52,73,74,93,96</sup> from soil,<sup>94</sup> from herbal formulations,<sup>97</sup> from food,<sup>98</sup> from different biological matrices<sup>99–101</sup> and from a titanium dioxide suspension.<sup>102</sup> For the determination of phenylurea herbicides at ultratrace levels (0.3–1 ng l<sup>-1</sup>), an SPE/SPME combined extraction method was described.<sup>96</sup> Surprisingly, after two extraction and derivatization steps the RSD was below 10%. A manual SPME/HPLC device combined with

MS detection was used for the measurement of fire ant pesticides in water samples. The extraction time was only 10 min and the detection limit was  $100 \text{ ng l}^{-1}$  for avermectin using Carbowax-templated resin fibre and  $1000 \text{ ng l}^{-1}$  for hydramethylnon using PDMS-DVB fibre.<sup>95</sup>

Since the addition of organic lead compounds has become prohibited, methyl tert-butyl ether (MTBE) has been used as an octane enhancer in order to reduce emissions when gasoline is burned in the engine. However, due to vehicular emissions and underground petroleum storage leaking, MTBE is beginning to appear in ground and surface water, raising serious concerns regarding environmental toxicity hazards.<sup>103</sup> HS-SPME/GC/MS with an SPME cryostat and  $75 \mu\text{m}$  PDMS-Carboxene fibre was used for extraction of MTBE from the air.<sup>104</sup> Piazza *et al.* used DVB-Carboxene fibre for determination of MTBE in water samples.<sup>105</sup> Using MS for detection, the LOD was  $14 \text{ ng l}^{-1}$ , which is almost 1000 times lower than the US EPA regulation ( $13000 \text{ ng l}^{-1}$ ).<sup>105</sup> More limited data are available for the determination of MTBE in marine samples, but the SPME/GC/MS technique can also be used.<sup>106</sup>

The determination of the chemical forms of arsenic in the environment is critical because of the different toxicities of arsenic species. The widespread use of inorganic and arsenic compounds in agriculture and industry results in a significant anthropogenic input of this element into the environment. On the other hand, natural sweet water and oceanic waters also contain inorganic arsenic.<sup>107</sup> In the liver of humans and mammals, there is a methylation mechanism for the detoxification of inorganic arsenic. As a result of this detoxifying process, the major part of the detectable amount of arsenic in the body is in the form of dimethylarsinic acid (DMA) and monomethylarsonic acid (MMA). In the case of arsenic speciation, the separation technique is typically HPLC and the detection method is atomic spectroscopy. For a more selective and sensitive approach SPME/GC/MS methods have been described with or without a derivatization process.<sup>38,108</sup> For the determination of arsenic compounds in tap water and soil samples, DI-SPME/GC/MS is combined with dithiol derivatization. The detection limit for 2-chlorovinylarsonous acid was  $2 \mu\text{g L}^{-1}$  using a  $100 \mu\text{m}$  PDMS fibre for the extraction, which is 400 times more sensitive than the classical Soxhlet extraction. An RSD of lower than 10% was typical.<sup>108</sup> HS-SPME/GC/MS was successfully used for the extraction of arsenic compounds from complex sediment matrices.<sup>109</sup> In-tube SPME combined with HPLC/MS detection was developed by Wu *et al.* for the determination of arsenic compounds in water samples.<sup>110</sup> They used a polypyrrole-coated capillary prior to HPLC separation and quadrupole MS detection. Using a polypyrrole in-tube coating was more effective for anionic species than the other coatings (PDMS, PDMS with 5% phenyl, polyethylene glycol). The method has been tested on a certified reference material (DORM-2).

Mercury pollution has become a global problem because of its occurrence from natural and anthropogenic sources and its biochemical processes. The determination and monitoring of mercury are of special concern in the field of heavy metal analysis. SPME extraction can be used for sample

preparation for inorganic and organic forms of mercury from water and sediments. For HS-SPME, extraction of inorganic salts has been preceded by conversion to an organomercury form.<sup>61</sup> Cai and Bayona described a procedure for the determination of methylmercury and labile  $\text{Hg}^{2+}$  in fish and river water matrices.<sup>59</sup> This procedure involves aqueous-phase derivatization of ionic mercury species with sodium tetraethylborate to ethylmercury and diethylmercury. The detection limit of the procedure for HS-SPME sampling was  $3.5$  and  $7.5 \text{ ng l}^{-1}$  (as Hg equivalent) for mercury and methylmercury, respectively. On the other hand, the detection limit of DI-SPME was  $6.7$  and  $8.7 \text{ ng l}^{-1}$  (Hg equivalent) for methylmercury and mercury, respectively. The reported process is simpler than the previously reported LLE methods. Another advantage is that the chromatogram is free from interferences. Compared with the purge and trap method, the SPME method eliminates the use of liquid nitrogen and possible blockage of the column due to water condensation. Yang *et al.* used isotope dilution calibration for the determination of methylmercury in fish tissues. The analyte was propylated after extraction from the HS using a  $100 \mu\text{m}$  PDMS extraction fibre. The detection limit for this method was  $37 \mu\text{g kg}^{-1}$ .<sup>111</sup>

Organotin compounds have been introduced into the environment mainly through their use as insecticides, fungicides, bactericides, wood preservatives, plastic stabilizers and biocides in antifouling paints for boats and ships. Their severe toxic effects on aquatic organisms and mammals, including humans have been observed even at very low concentrations ( $\text{ng l}^{-1}$ ).<sup>112</sup> Bancon-Montigny *et al.* developed a unique method to improve the precision of the quantification of tributyltin (TBT) in sediments by SPME using isotope dilution GC/MS.<sup>113</sup> The precision of the technique when using tripropyltin as internal standard was 12%. Using <sup>117</sup>Sn-enriched TBT as internal standard the precision was 4% and the detection limit of TBT was  $200 \text{ pg l}^{-1}$ . The isotope dilution technique eliminated the problem of poor reproducibility, which typically plagues SPME.

### Applications in food chemistry

Food analysis is important for the evaluation of nutritional value, for quality control of fresh and processed products and the monitoring of food additives and other toxic contaminants. In general, flavour is sensitive to compositional alterations. In the case of food (fruit, wine, etc.) flavours the volatile aromatic compounds are produced through metabolic pathways during ripening, harvest, post-harvest and storage, and their production depends on many factors related to the species, variety and type of technological treatment.<sup>114,115</sup> Therefore, it is important to know the typical chromatographic pattern of a given food product (fresh fruit, authentic wine sample, etc.) and the modified pattern during processing or storage in order to identify changes in the volatile composition. In addition, monitoring adulteration is vital to the industry and the health of the consumer. Foodstuffs are prone to deterioration by light, heat, oxidation and contamination from the container (or from the packing material) during storage. Many protein-containing foodstuffs are known to release ammonia and amines through microbial

deamination and decarboxylation of amino acids.<sup>5</sup> Early detection of the vapours from foodstuffs can be used to prevent widespread infections in stored foods. Since the SPME extraction technique became commercially available it has been used for the analysis of different foods and food materials.<sup>116</sup> Various SPME methods have been applied to the analysis of various components and contaminants in a range of different food samples. Aroma and flavour are among the most important quality criteria of fresh and processed foods and both qualitative and quantitative information is desired for characterizing aroma-producing compounds. Aroma and flavour compounds usually occur at extremely low concentrations in complex food matrices and consist of a wide variety of organic compounds possessing various polarities and reactivities. Fortunately, most aroma and flavour compounds are volatile and procedures for their isolation from food samples have been established by taking advantage of this volatility. However, commonly used sampling methods such as steam distillation, solvent extraction, trapping of the volatiles on adsorbents or combinations of these methods with other techniques prior to chromatographic separation<sup>117</sup> are very labour intensive. Using SPME combined with GC/MS (or GC/flame ionization detection (FID)), the disadvantages of these commonly used sample preparation methods can be avoided. One of the most important and interesting areas in flavour analysis is the characterization, the differentiation of the different classes of foods by their aroma composition. Various types of fibres have been tested for this purpose. Most of the HS extraction methods are performed with 100 µm PDMS fibre, which is the largest capacity fibre for apolar compounds and it can collect effectively the different components from the sample HS. For the characterization of a food product it is necessary to measure a large number of samples and extract a large number of compounds with good reproducibility. Needless to say, low analysis costs and short analysis times are also essential. For the analysis of chromatographic data, chemometric techniques, such as principal component analysis (PCA),<sup>118</sup> and special user-constructed aroma libraries have been used.<sup>119</sup>

A special gas sensor array apparatus was developed by Freitas *et al.* for the characterization of coffee products.<sup>118</sup> They used 100 µm PDMS fibre for HS-SPME extraction. The gas sensor array was much faster than SPME/GC/MS but the with GC/MS method the identification of compounds is also possible. Both methods can differentiate Arabica and Robusta coffee varieties. Augusto *et al.* employed SPME/GC/MS to isolate and identify the main aroma constituents of Brazilian tropical fruits. They identified several alcohols, esters, carbonyl compounds and terpenoids. The best extraction efficiency was achieved using a Carboxen fibre for HS sampling.<sup>120</sup> Combining the HS-SPME technique with olfactometry has been used for the characterization of essential oils from black and white pepper or from pepper plants.<sup>121</sup> For the characterization of flavour-related toxic or carcinogenic compounds (alkylbenzenes, etc.) in Indian bidi cigarette, automated HS-SPME/GC/MS was used.<sup>122</sup> Using a polar polyacrylate-coated extraction fibre it is also possible to extract polar analytes from the HS. Pinho *et al.* developed an HS-SPME/GC/MS method for analysing

volatile free fatty acids (C<sub>4</sub>, C<sub>6</sub>, C<sub>8</sub>, C<sub>10</sub>) in ewe cheese<sup>123</sup> and they also studied the volatile compounds of Terrincho cheese.<sup>124</sup> The volatile flavour profile of the fruits also changes during the ripening and the storing period.<sup>125–127</sup> It is important to follow the aroma profile during the ripening to determinate the optimal harvest time. In other cases some of the important fruit volatiles were very sensitive to the storage time and the state of ripeness. Aroma constituents of many medicinal plants are also strongly influenced by several environmental and ripening and storage factors. It is well known that the concentration of the biologically active material is completely different at different periods and therefore to estimate a proper harvest time is essential.<sup>128</sup> Lavender essential oil is employed in flavouring beverages such as ice cream, candy, etc. Kim and Lee compared different extraction methods for the analysis of different *Lavandula* species. The most efficient extraction medium was a 100 µm PDMS-coated extraction fibre.<sup>129</sup> Another interesting application for SPME is to evaluate potential differences between a healthy and infected fruit<sup>130</sup> or between a healthy or wound-induced plant.<sup>131</sup> Paliyath *et al.*<sup>130</sup> studied the volatile production of apples. They explored the relation between the superficial scald and volatile production of the fruit. The HS-GC/MS method using a 100 µm PDMS filter was fast and effective. Comprehensive two-dimensional GC was successfully applied by Perera *et al.*<sup>131</sup> for the characterization of different mechanically wounded plants. The emission rate of volatile organic compounds (VOCs) from mechanically damaged plants to the atmosphere is much higher than in the case of undamaged plants. The VOC profile for cut grass emissions was different from that for uncut grass emissions, the former being enhanced in longer chain (>C<sub>6</sub>) oxygenates. The authors extracted the HS of the different plants using Carboxen-PDMS and a 100 µm PDMS extraction fibre to compare plant-to-plant differences. It is important to note that the cleaning step between extractions is very important. They found that the Carboxen-PDMS fibre has a strong carryover effect due to larger molecules, which are strongly retained on the surface of the fibre. Two extraction fibres (75 µm Carboxen and 50/30 µm Carboxen-divinylbenzene) were used for the extraction of volatile aroma compounds of cooked pork meat samples applied by Elmore *et al.*<sup>132</sup> After the extraction, the two fibres were desorbed in the injection port of a GC/MS system sequentially, so that the aroma compounds from both of the fibres could be analysed in one GC/MS chromatogram. This procedure resulted in a chromatogram containing a more complete aroma profile for cooked pork than the chromatograms from either of the fibres on their own. Mitani *et al.* developed an automated on-line in-tube SPME/HPLC method for the determination of the isoflavones from hydrolysed soybean products.<sup>133</sup> They used repeated draw-eject cycles as a sample preparation and preconcentration step using a Supel-Q porous layer open-tubular capillary column. The extracted compounds were easily desorbed from the capillary by a mobile phase flow and a carryover effect was not observed. The detection limit was 0.4–0.5 µg l<sup>-1</sup> and the cycle time was less than 15 min.

One of the most important and well-studied areas of the food analysis is the analysis pesticides, herbicides, fungicides and other agrochemical products in foods.<sup>5,134–136</sup> Consequently, health risks connected with the use of these chemicals and residues in foods have received a great deal of attention because they impact the daily life of people everywhere in the world. The residues of these chemicals in agricultural and agroindustrial samples should be monitored to determine that they are within specified limits. There is an urgent need for an analytical sample preparation method that is simple, sensitive, rapid and applicable to a variety of food samples. Fortunately, the SPME sample preparation technique combined with MS meets these requirements. Various pesticide and fungicide residues in vegetables and fruits have been analysed by SPME coupled with GC/MS.<sup>134,137</sup> For polar pesticides an automated high-sensitivity in-tube extraction HPLC/MS method has been developed by Wu *et al.*<sup>136</sup> They extracted and monitored 12 different types of phenylurea and carbamate pesticides from wine samples using a polypyrrole extraction tube.

The packing materials are in direct contact with food products. Generally they are flexible and multilayer polymers and sometimes contain low molecular mass contaminants (carbonyl compounds, aldehydes, hydrocarbons, etc.) which are responsible for undesirable odour and taste.<sup>138</sup> These compounds are formed by the thermooxidative degradation during the extrusion coating process in the manufacture of packaging<sup>139</sup> or some aromatic compounds are residues of the printing process. For the determination of these residues the conventionally used static HS methods are not sufficiently sensitive. Owing to their volatility, the HS-SPME method can be adopted to solve these problems. Ezquerro *et al.* used 75  $\mu\text{m}$  Carboxen–PDMS fibre for extraction, GC/MS for detection and external standard calibration for the quantification of 22 compounds formed by thermooxidative degradation of polyethylene packing material.<sup>140</sup>

### Analysis of wines and other alcoholic beverages

HS-SPME is one of the most popular extraction techniques for the characterization of different alcoholic drinks based on their volatile composition<sup>115,141–144</sup> or to extract specific trace components from the HS.<sup>145,146</sup> Surprisingly, the majority of the articles described different analytical techniques to characterize wine aroma compounds. Aromas are the most important components of wines and about 1300 compounds have been identified. Part of them are present in the grape but most of them are formed during fermentation. Aroma production is influenced by various factors: environment, grape variety, ripeness, fermentation conditions,<sup>147</sup> the wine production process<sup>114,148</sup> and ageing. The combination of different aroma compounds forms the character of wine and differentiates one wine from another. Based on their volatile composition, many different wines have been studied for their region of origin. Italian,<sup>149–151</sup> German,<sup>152–154</sup> Spanish,<sup>155,156</sup> Portuguese,<sup>157</sup> Sardinian,<sup>158</sup> Hungarian (Fig. 9) and Greek<sup>159</sup> wines have been described. SPME can extract a few tens of different aroma components from the HS of the wines. This method is fast and reproducible and it has

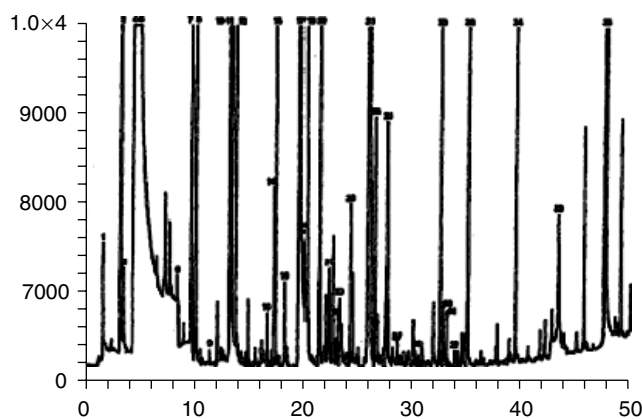

**Figure 9.** Typical chromatogram (total ion current) obtained from HS-SPME/GC/MS analysis of a Hungarian Blaufrankisch sample. Reproduced from Ref. 17, with permission of Preston Publications.

a minimal effect on the very sensitive equilibrium systems of the wines, and therefore it is ideal for statistical data treatment.<sup>119,160</sup>

The results show that various SPME methods combined with GC/MS are suitable to compare and optimize different wine-making processes and can be correlated with organoleptic properties. Cork taint, a mouldy/musty off-odour in affected bottles, is one of the most serious problems affecting the wine industry (estimated to cause the loss of US \$10 billion annually). Evans *et al.*<sup>145</sup> used automated HS-SPME/GC/MS for the rapid quantitative determination of 2,4,6-trichloroanisole (TCA) in wine samples. Cork taint is caused by TCA. The human sensory threshold for TCA is about 1.4–10  $\text{ng l}^{-1}$ . The developed SPME method using deuterated TCA as an internal standard is as sensitive as a human nose (limit of quantification 5  $\text{ng l}^{-1}$ ) and the RSD is 5–13%, which is acceptable at that low concentration range. Using the stir bar desorption technique with a PDMS<sup>161</sup> coating and GC/MS with selected ion detection ( $m/z$  197), TCA can be detected below the 1  $\text{ng l}^{-1}$  level.<sup>162</sup> Luan and *et al.*<sup>146</sup> established a new 'on the fibre derivatization' method for the determination of *trans*-resveratrol by SPME/GC/MS. Resveratrol is one of the most interesting wine components. Recently, it has been suggested that resveratrol in wine can reduce the risk of carcinogenesis.<sup>163</sup> The former extraction methods were based on SPE and were time consuming and labour intensive, and unfortunately resveratrol is very sensitive to environmental effects (light, pH, oxygen, temperature). The DI-SPME extraction method using GC/MS works with minimal sample manipulation, and is fast (30 min) and sensitive (detection limit 5  $\text{ng l}^{-1}$ ).

The aroma compositions of different whisky samples were studied by Demyttenaere *et al.*<sup>164</sup> They compared the 'classical' SPME and the new SBSE extraction method. The best results were obtained by using PDMS and a Carboxene–DVB–PDMS fibre for the DI extraction. SBSE is also an appropriate method for characterization but its main drawback is that it requires a special and expensive thermal desorption unit for the injection.

### Application to biological fluids

Sample preparation is one of the most critical steps in the analysis of biological fluids and compounds in biological matrices. A few years ago mainly LLE and SPE were used. In order to increase the sample throughput, improve the quality of analytical methods and reduce the analysis costs, new techniques are being developed for this purpose. SPME is one of the most promising sample preparation methods for biological samples. HS-SPME is ideal for the analysis of biological specimens as interference from high molecular mass components, such as proteins in the matrix, is reduced, yielding cleaner extracts. In particular, the application of HS-SPME/GC/MS in forensic toxicology and environmental medicine appears to be promising.

Urine is a relatively simple biological fluid to collect and is frequently used for drug screening, forensic purposes, monitoring workplace exposure to chemicals and other investigations as it contains the target analytes together with diagnostic metabolites. Early SPME applications focused on very volatile compounds such as ethanol and solvents in urine. Nowadays a variety of drugs (amphetamines, antihistamines, tricyclic antidepressants,<sup>33</sup> corticosteroids<sup>165</sup>), organometallics,<sup>16,38,60</sup> inorganic mercury,<sup>166,167</sup> pesticides and industrial chemicals<sup>168,169</sup> can be measured. The research group of Kojima has pioneered many methods.<sup>170</sup> HS-SPME is suitable for the measurement of drugs in urine as matrix effects are minimal and sample preparation is simple.<sup>171</sup> By the use of high incubation temperatures even semivolatile compounds can be measured. Some drugs may be extracted from steam at vial temperatures above 100 °C. In the analysis of semivolatile drugs, long equilibrium times (20–60 min) are often required. In general, most of the drugs mentioned above can be satisfactorily extracted on a thick (100 µm) film PDMS fibre. Detection limits vary according to the class of drug, but typically are in the range 0.2–100 µg l<sup>-1</sup>. One of the most popular applications of SPME in urine analysis is determination of amphetamines and their metabolites. Owing to the widespread abuse of amphetamine, metamphetamine and the 'designer drugs' 3,4-methylenedioxymetamphetamine (MDMA, Ecstasy) and 3,4-methylenedioxyamphetamine (MDA), drug testing for amphetamines is routinely done in forensic toxicology. HS-SPME,<sup>172</sup> DI-SPME and in-tube-SPME combined with HPLC/MS detection<sup>22</sup> can be used for the extraction of these compounds. One of the first developed qualitative and quantitative methods was described by Yashiki and *et al.*<sup>170</sup> and was based on HS extraction and chemical ionization MS. The sensitivity of the proposed method is 100 µg l<sup>-1</sup>, which is 20 times better than the conventional HS method. This sensitivity is not the best available, but the sample preparation is simple and fast (20 min for incubation and 5 min for extraction), therefore it is ideal for high-throughput screening methods. Huang *et al.*<sup>173</sup> used an on-fibre derivatization approach using an 8:2% v/v mixture of heptafluorobutyric chloride and heptafluorobutyric anhydride for on-fibre derivatization. They extracted the components at 100 °C for 20 min. The detection limits were 0.3 µg l<sup>-1</sup> for metamphetamine and 1 µg l<sup>-1</sup> for amphetamine.<sup>173</sup> The extraction device is shown in Fig. 10.

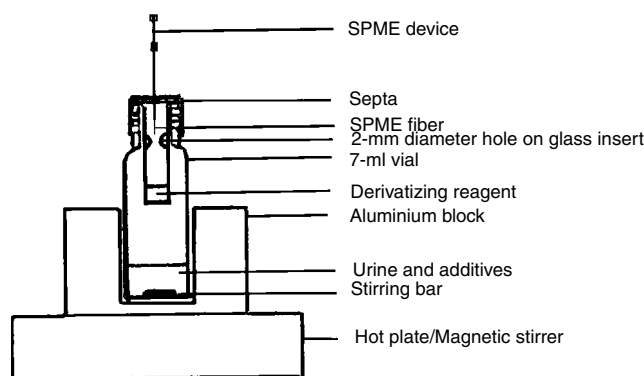

**Figure 10.** Schematic of the extraction and derivatization device for amphetamine determination. Reprinted from *The Analyst*, **127**, Huang MK, Liu C, Huang SD, One step and highly sensitive headspace solid-phase microextraction sample preparation approach for the analysis of methamphetamine and amphetamine in human urine, page 1204, Fig. 1, Copyright (2002). Reproduced by permission of The Royal Society of Chemistry.

Ugland *et al.* developed an automated DI-SPME/GC/MS method for the determination of amphetamines and their methylenedioxyated analogues by propyl chloroformate derivatization.<sup>174</sup> The detection limit is 5 µg l<sup>-1</sup> for metamphetamine, which is acceptable, but the method is automated and the cycle time is only 17 min, which means that 85 samples can be analysed in 24 h. The simplest DI-SPME method was developed by Myung *et al.*<sup>175</sup> Stimulant drugs (amphetamine, metamphetamine and dimetamphetamine) were transferred directly to the GC/MS system without any derivatization processes. Poli *et al.* developed an HS-SPME/GC/MS method for the determination of inhalation anaesthetics (nitrous oxide, isoflurane, halothane).<sup>176</sup> The method is based on extraction with a 2 cm long Carboxene–DVB–PDMS-coated extraction fibre, which was compared with a Carboxene–PDMS fibre. Linearity was established over four orders of magnitude and the detection limit for nitrous oxide was below 100 and 30 ng l<sup>-1</sup> for halogenated inhalants. High-temperature (100–200 °C depending on the analyte) HS-SPME with simultaneous *in situ* derivatization was used by Staerk and Külpmann for screening drug components in dried urine and confirmation analysis of suspected substances in dried serum<sup>177</sup> using MS detection. The detection limits of the measured analytes from urine were 200 µg l<sup>-1</sup> for amphetamines, 500 µg l<sup>-1</sup> for barbiturates, 100 µg l<sup>-1</sup> for benzodiazepines, 150 µg l<sup>-1</sup> for benzoylecgonine, 100 µg l<sup>-1</sup> for methadone and 200 µg l<sup>-1</sup> for opiates. In serum samples all drugs could be detected by selected ion monitoring within their therapeutic range. Mills *et al.* developed a new quantitative stable isotope dilution GC/MS procedure (deuterated TMA was the internal standard) for the diagnosis of trimethylaminuria (fish odour syndrome) by analysing trimethylamine (TMA) and trimethylamine oxide from urine samples using SPME for extraction.<sup>178</sup> A validated quantitative DI-SPME method using Carbowax–DVB fibre was published by Hall and Brodbelt<sup>179</sup> for the determination of barbiturates in urine samples using [<sup>2</sup>H<sub>5</sub>]pentobarbital as internal standard and

for spiking samples in standard addition. Determination of benzophenone-3 (widely used as a human skin protector from ultraviolet light in human cosmetics) and its metabolites such as 2,4-dihydroxybenzophenone and 2,2'-dihydroxy-4-methoxybenzophenone can also be done in urine samples by using DI-SPME for the extraction and GC/MS for analysis.<sup>180</sup> The analysis of sulfur-containing amino acids (methionine, cysteine, homocysteine) used HPLC with fluorescence detection after fluorescent tagging. This method was not selective and required complex sample preparation and derivatization. These amino acids are important because they can be used as biomarkers for the risk assessment of vascular disease. Myung *et al.* developed a rapid, simple and inexpensive DI-SPME extraction method combined with MS detection for the determination of these amino acids in urine samples.<sup>181</sup> For application to a GC/MS system, alkyl formate derivatives were prepared in aqueous samples prior to SPME extraction. SPME extraction using Carbowax-templated resin, followed by HPLC separation and ESI-MS was used for simple and fast (6 min extraction time and 5 min desorption time) determination of the isoflavone aglycones genistein and daidzein.<sup>182</sup> The sensitivity of the validated HPLC/MS method is  $2.7 \text{ ng l}^{-1}$  for genistein and  $25.4 \text{ ng l}^{-1}$  for daidzein. Daidzein and genistein were detected in urine following consumption of a soy drink.

One of the most promising areas of SPME sample preparation of biological samples is that using in-tube fibre extraction combined with HPLC/MS detection. Kataoka *et al.* developed an in-tube extraction method for the quantification of ranitidine, which is the histamine  $\text{H}_2$  receptor antagonist and is used for the treatment of duodenal and stomach ulcers.<sup>183</sup> The authors used a  $60 \text{ cm} \times 0.25 \text{ mm i.d.}$  Omegawax-250 coated ( $0.25 \mu\text{m}$  film thickness polyethylene glycol) quartz capillary column for extraction. After 10 aspirate/dispense steps the extracted ranitidine can be easily desorbed by using methanol. After desorption, the analytes were separated on a Supelcosil LC-CN column and then analysed by MS. The cycle time of the analysis was 16 min and sample carryover was below 1% when using an autosampler. The detection limit was about  $1.4 \mu\text{g l}^{-1}$  and the inter-day and day-to-day variations were 2.5 and 6.2%, respectively. On the other hand, Wu *et al.* developed a polypyrrole-coated in-tube SPME method for the determination of amphetamine, metamphetamine and their methylenedioxy derivatives (MDA, MDMA and MDEA) in hair and from urine samples.<sup>22</sup> The sample treatment for urine analysis is simple (1:10 dilution with water) but for hair samples the treatment is a multi-step procedure.<sup>184</sup> The sensitivity of the method is  $8\text{--}56 \text{ ng l}^{-1}$  using 10-cycle extraction and the total analysis time is  $\sim 20$  min.

The direct HS analysis of whole blood is problematic owing to clot formation during heating of the HS vial. Deproteinization pretreatment can be used but this can lead to losses of very volatile compounds. The addition of a strong alkali (NaOH is the most often used) to the sample causes haemolysis and thus prevents clot formation. The use of MS for detection can reduce interferences and decrease the detection limit. A range of compounds can be

extracted and analysed such as industrial solvent residues,<sup>185</sup> insecticides,<sup>186</sup> pesticides,<sup>101</sup> amphetamines, anaesthetics, diazepines<sup>187</sup> and different drug metabolites. Amphetamine and related compounds are one of the 'favourite' target components in SPME blood analysis, similar to urine analysis. Trace levels of amphetamine and metamphetamine was determined by DI-SPME and HS post-derivatization with heptafluorobutyric anhydride using a PDMS fibre.<sup>188</sup> The serum matrix was diluted 1:3 with buffer solution. The detection limits were at the  $\text{ng l}^{-1}$  level using a specially designed extraction vessel for sample preparation (Fig. 11<sup>188</sup>).

Kojima's group developed various HS-SPME methods for the determination of amphetamines in blood samples. They developed a method for the simultaneous analysis of fenfluramine (widely used as an appetite suppressant), amphetamine and metamphetamine using HS-SPME with on-fibre derivatization with heptafluorobutyric anhydride and GC/MS detection.<sup>189</sup> The most sensitive approach for the determination of amphetamine and metamphetamine was using tri-*n*-propylamine and pentafluorobenzyl bromide as derivatization reagent. In that case the sensitivity, of the method was  $0.5 \text{ ng g}^{-1}$  for both amphetamine and metamphetamine.<sup>190</sup> Kojima's group also developed a simple and sensitive method for the determination of

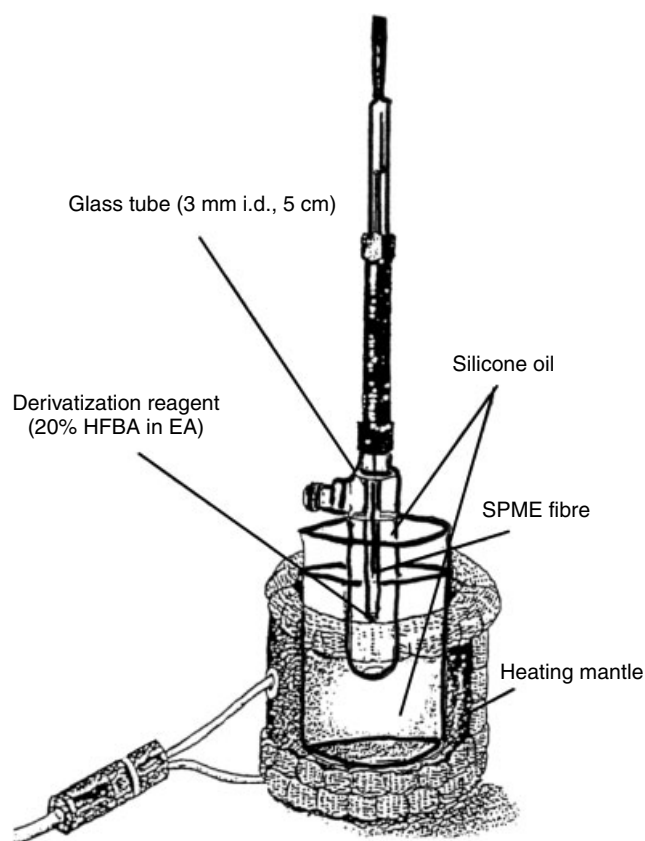

**Figure 11.** Headspace derivatization kit for amphetamine and metamphetamine using SPME. Reprinted from *Journal of Chromatography A*, **896**, Lee MR, Song YS, Hwang BH, Chou CC, Determination of amphetamine and metamphetamine in serum via headspace derivatization solid-phase microextraction-gas chromatography-mass spectrometry, page 267, Fig. 1, Copyright (2000), with permission of Elsevier.

local anesthetics.<sup>191</sup> The high-temperature (120 °C) HS-SPME method using deuterated lidocaine (*d*<sub>10</sub>-lidocaine) with MS detection has good sensitivity in the range 10–500 ng g<sup>-1</sup> depending on the analyte.

An automated in-tube solid-phase microextraction method was developed by Walles *et al.* for the determination of verapamil (a common calcium antagonist with antianginal, antihypertensive and antiarrhythmic properties).<sup>192</sup> Most of the former methods are based on labour-intensive and

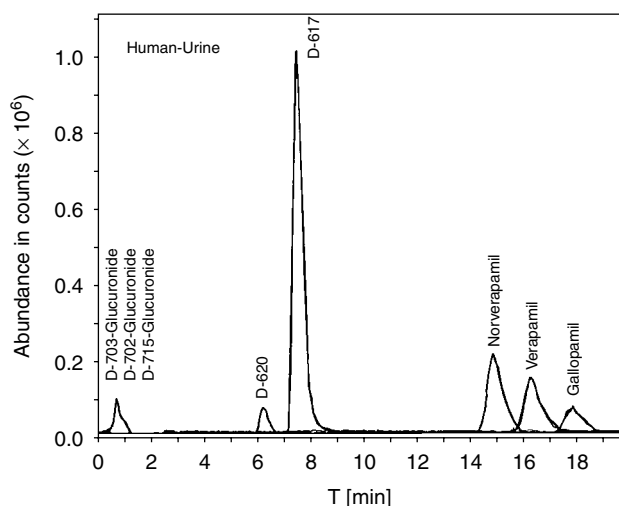

**Figure 12.** Typical HPLC trace of verapamil and metabolites extracted from cell culture by in-tube SPME with a polypyrrole-coated capillary. Reprinted from *Journal of Pharmaceutical and Biomedical Analysis*, **30** (2), Walles M, Mullett WM, Levsen K, Borlak J, Wunsch G, Pawliszyn J, Verapamil drug metabolism studies by automated in-tube solid phase microextraction, page 314, Fig. 4, Copyright (2002), with permission of Elsevier.

time-consuming extraction such as solvent extraction or SPE. In-tube SPME can replace these methods for automatic extraction of verapamil and its metabolites from different biological matrices, e.g. plasma and cell cultures from *in vitro* assays. For extraction of the analytes they used a 60 cm long-polypyrrole coated quartz capillary. The detection limit for Verapamil and related compounds was 5–8 µg l<sup>-1</sup> with a total sample preparation and analysis time of 34 min. A typical chromatogram of a urine sample is shown in Fig. 12.<sup>192</sup>

### Hair analysis

Hair analysis is frequently used for the long-term monitoring of drug and alcohol users. HS-SPME as the advantage of producing a high purity of the extract with no interferences. It is a convenient one-step method for the measurement of many lipophilic basic drugs such as nicotine, amphetamine and related compounds, local anaesthetics, phencyclidine, ketamine, methadone, tricyclic antidepressants and phenothiazines. A schematic drawing of the equipment which can be used for HS hair sampling is shown in Fig. 13.<sup>193</sup>

Gentili *et al.* developed an HS-SPME method for the simultaneous detection of MDA, MDMA, MDE (methylenedioxyamphetamine), and MBDB (*N*-methyl-1-(1,3-benzodioxol-5-yl)-2-butanamine) using a 100 µm PDMS fibre for extraction at 71 °C with MS detection.<sup>194</sup> All positive samples were confirmed by using MS/MS and positive chemical ionization techniques. The method sensitivity is 0.7–1.9 µg g<sup>-1</sup> depending of the analyte and the method is suitable for routine clinical, epidemiological and forensic purposes and can also be used for the preliminary screening of other substances (amphetamine, metamphetamine, ketamine, ephedrine, etc.). Liu *et al.* analysed metamphetamine and amphetamine after alkali digestion and derivatisation with heptafluoro-*n*-butyryl chloride prior to GC/MS detection.<sup>195</sup> Sporkert

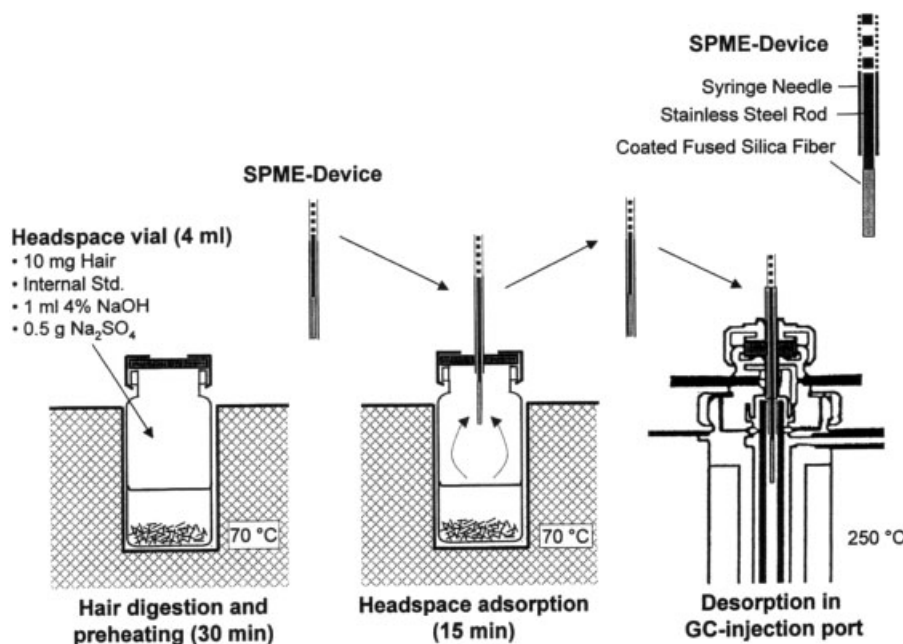

**Figure 13.** Schematic drawing of the HS-SPME sampling device for hair analysis. Reprinted from *Forensic Science International*, **107**, Sporkert F, Pragst F, Use of headspace solid-phase microextraction (HS-SPME) in hair analysis for organic compounds, page 130, Fig. 1, Copyright (2000), with permission of Elsevier.



and Pragst detected 22 different drug substances from alkali-digested hair samples using HS-SPME.<sup>193</sup> They also published an automatic method for the determination of methadone and its metabolites.<sup>196</sup> A typical GC/MS chromatogram of a drug-spiked hair sample is shown in Fig. 14.<sup>193</sup>

Some interesting papers have been published on the determination of chronically elevated alcohol consumption.<sup>197,198</sup> The search for suitable markers of chronically elevated alcohol consumption has been a topic of research for decades with very important clinical and forensic implications. Hair analysis proved to be an important diagnostic tool for the detection of chronic drug abuse, but so far this approach has never been applied to ethanol abuse. The high volatility of ethanol is believed to make its direct detection in hair difficult, but some direct and indirect markers can be correlated with high alcohol consumption. There is a range of possible direct markers, which were discussed by Pragst *et al.*,<sup>197</sup> they found that ethyl esters of long-chain fatty acids (C<sub>16</sub>, C<sub>18</sub> and oleic) (FAEE) are potential markers for alcohol abuse. Fortunately, they can be extracted and concentrated with HS-SPME after previous extraction with chloroform–methanol. FAEE concentration could be affected by frequent hair waxing or using alcohol-containing (60% or higher alcohol content) hair care products<sup>198</sup> and that can cause false-positive results.

**Breath analysis–volatile metabolites of microorganisms**

Non-invasive sampling and chemical analysis of breath gases could provide valuable information related to health and also a tool for the diagnosis of diseases. Breath gases are indicators of metabolic end products.<sup>199</sup> Furthermore, the analysis of breath gases is relatively simple since the matrix is less complex than in the case of blood or urine. In spite of these obvious advantages and the good results obtained, analysis of exhaled air is not frequently used, probably owing to the lack of a standardized sampling system, which makes interpretation difficult. HS-SPME was used to collect rapid on-site breath samples using DVB–Carboxen–PDMS (50 : 30) and 100 μm PDMS for the extraction of bovine breath gases.<sup>200</sup> Acetone, methyl ethyl ketone, toluene, tetradecane,

pentadecane, nonanal and decanal was identified in cattle-breath using GC/MS. A schematic of the face mask-like sampling device can be seen in Fig. 15.<sup>200</sup>

Prado *et al.* monitored organic compounds in human end-exhaled air samples using tetrachloroethylene as a model compound and 100 μm PDMS fibre for extraction.<sup>201</sup> The capacity of humans to metabolize tetrachloroethylene is very limited, therefore it is a good model of respiratory elimination. The SPME methods simpler and less expensive than the official sorbent extraction followed by thermal desorption. Hence it provides a practical tool for biological control of occupational exposure in industrial hygiene studies.

HS-SPME can also be applied for the extraction of volatile metabolites emitted by different microorganisms (algae, fungi, bacteria, etc.).<sup>202</sup> However, it is interesting that about 90% of the volatile aroma compounds of wine and beer are also metabolism products of different yeast specimens.<sup>147</sup> HS-SPME/GC/MS looks like an ideal tool for the characterization of different *Penicillium* species based on their characteristic volatile metabolite pattern.<sup>203</sup> Lloyd *et al.* determined geosmin and 2-methylisoborneol at the 10 ng l<sup>-1</sup> level in water samples using MS detection.<sup>204</sup>

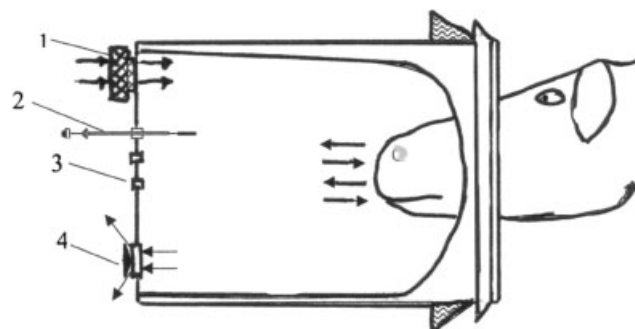

**Figure 15.** Schematic drawing of a face mask-like breath sampling device. 1, Ambient air filter; 2, SPME device; 3, septa; 4, one-way valve. Reprinted from *Biosystems Engineering*, **84**, Spinhirne JP, Koziel JA, Chirase NK Device for non-invasive on-site sampling of cattle breath with solid-phase microextraction, page 240, Figure 1, Copyright (2003), with permission of Elsevier.

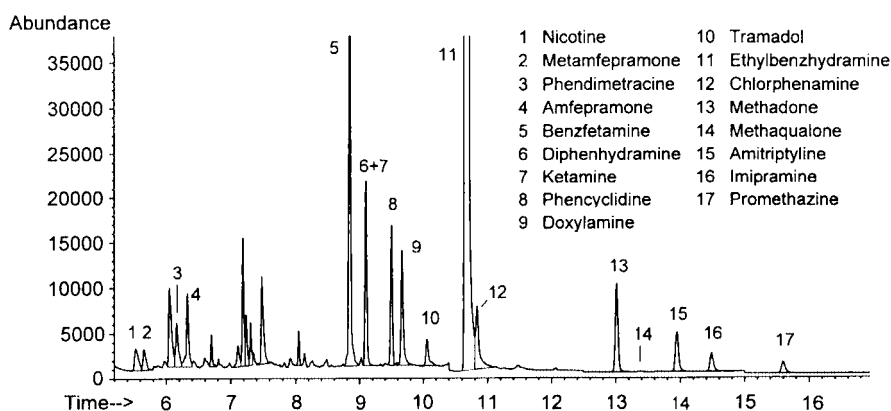

**Figure 14.** Typical GC/MS chromatogram of a drug-spiked hair sample. Reprinted from *Forensic Science International*, **107**, Sporkert F, Pragst F, Use of headspace solid-phase microextraction (HS-SPME) in hair analysis for organic compounds, page 138, Figure 6, Copyright (2000), with permission of Elsevier.

These two algae metabolites have a strong muddy/musty odour character and the human nose can detect them at the 4–20 ng l<sup>-1</sup> level. Some fungal metabolites (2-pentanol, 2-heptanone, etc.) are also very good indicators of water-damaged, mould-infested building materials.<sup>205</sup> The main advantages of using SPME to solve these problems is that SPME is a hand-size extraction device and it can be easily used as a field sampler.

## NEW DEVELOPMENTS

New developments in SPME sample preparation are directed at developing smaller volumes for the extraction fibres<sup>206</sup> and further development of the in-tube extraction technique.<sup>28,29</sup> Miniaturized sample preparation methods have been regarded as the most attractive techniques for the pretreatment of complex sample mixtures prior to the chromatographic process. The main advantages of the miniaturized systems are high-speed analysis with high efficiency, low cost and environmentally friendly operation due to the minimal or no solvent consumption, and highly selective analysis by developing tailored systems designed for particular applications.<sup>28–33</sup> Extracting very small amount of samples (10–35 µl) is difficult but in a biological sample treatment sometimes the sample amount is very limited (saliva, mouse urine, etc.) and many extractions should be done from a small amount.<sup>206</sup> On the other hand, the short diffusion path (which is very important when the matrix is highly viscous, such as plasma) favours establishment of equilibrium, and therefore the extraction times are much shorter. Next, even if the concentration of analytes is at a high level, the total amount of analytes in the small volume is still low and the linear range of the calibration curve obtained by SPME will extend to higher concentrations. The technique is less affected by experimental conditions, therefore it is more reproducible. Finally, the small-volume sample also reduces possible interferences from the components in the matrix. The small-volume sampling procedure is almost the same as in conventional DI-SPME. A schematic of the sampling process is shown in Fig. 16.<sup>206</sup> First take a 5 cm length of 0.65 or 1.00 mm i.d. glass capillary and suck a 0.9–1.0 cm liquid column from the sample vessel (1), then fix the capillary in a vial with the aid of a septum (2). Insert the needle of the SPME fibre holder into the capillary (3) and depress the plunger to expose the fibre to the sample solution (4). Finally, retract the fibre and withdraw the needle from the vial (5) after equilibrium is reached.

A direct extraction probe has been developed by Pawliszyn's group, which is suitable for the direct extraction of metabolites from veins in *in vivo* pharmacokinetic studies.<sup>20,21</sup> Using a polypyrrole-coated extraction probe, dynamic living systems can be monitored without taking blood samples. This is a kind of direct immersion SPME sampling, well suited for the determination of drug concentrations and protein binding. The sensitivity of the method in the low µg l<sup>-1</sup> range and shows good linearity. This also allows the study of drug/metabolite concentrations at multiple sites in one specimen, helpful for the identification of metabolic pathways.

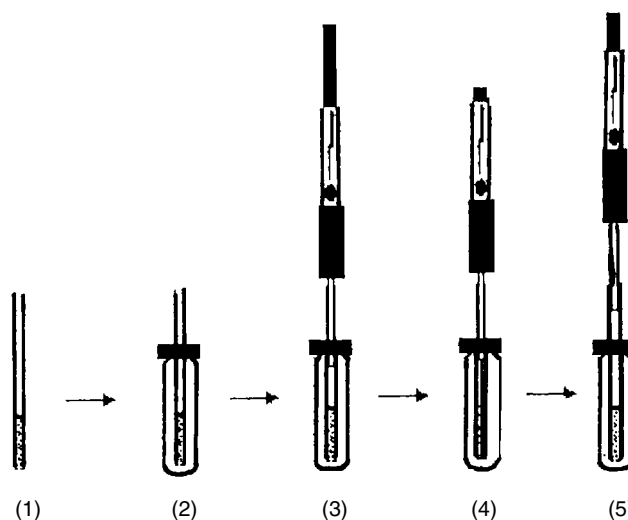

**Figure 16.** Procedure of small-volume SPME extraction. Reprinted from *Journal of Chromatography A*, **988**, Zhu PL, Liu CL, Liu MC, Solid-phase microextraction from small volumes of sample in a glass capillary, page 27, Fig. 1, Copyright (2003), with permission of Elsevier.

A promising new application is the use of SPME extraction fibres for matrix-assisted laser desorption/ionization (MALDI)<sup>207</sup> or direct coupling to electrospray/nanospray.<sup>208</sup> The concept of coupling SPME to MALDI is to combine sample extraction with the ionization procedure on the tip of a fused-silica optical fibre for biomolecular analysis. The sample end of the fibre was silanized with 3-aminopropyltriethoxysilane (APTES) for the extraction of analyte. Laser energy was transferred through the other end of the optical fibre to ionize and desorb the biomolecules for the subsequent analysis. This SPME/MALDI fibre was combined with an ion mobility spectrometer and a tandem quadrupole time-of-flight mass spectrometer for the detection of the MALDI signal. A schematic diagram of the SPME/MALDI system combined with ion mobility mass spectrometer can be seen in Fig. 17.<sup>207</sup> The SPME/MALDI combination possesses several attractive attributes such as the simplicity of sample preparation, minimized sample handling and one-step sample extraction/concentration directly from the biological sample on to the sample support. Only the preparation of the fibres requires extra time, but the fibres can be used for about 500 extractions (or laser shots). High biospecificity can be expected by employing the antibody-immobilized SPME technique for the extraction of complementary antigen. The application of this technique holds promise especially in biochemical analysis, pharmaceutical research, clinical diagnostics and screening.

Another interesting application for SPME sample preparation is capillary electrophoresis (CE) or CE/MS.<sup>209</sup> The prospects for CE in analytical applications are highly promising because of its very high separation efficiency, short analysis time and low consumption of expensive and toxic solvents. Combining the advantages of CE/MS analysis with the simplicity of SPME extraction, off-line SPME/CE/ES-MS was developed by Rodriguez *et al.* for the analysis of acidic pesticides in fruits. The CW-TPR extraction fiber was

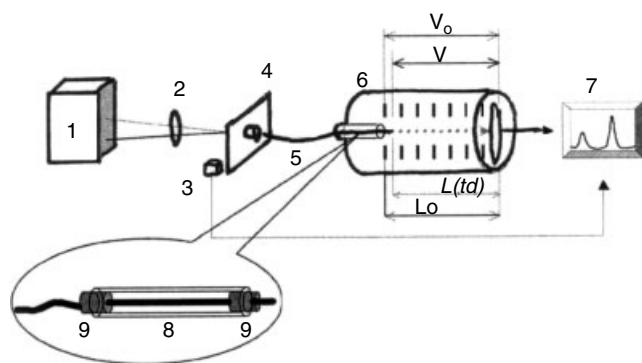

**Figure 17.** Schematic diagram of SPME/MALDI-IMS system. (1) Laser source; (2) focusing lens; (3) photodiode; (4) fibre holder; (5) SPME/MALDI fibre; (6) IMS, (7) oscilloscope; (8) glass tube; (9) fixing septum;  $V_0$  and  $V$ , designed and effective high voltage in drift tube, respectively;  $L_0$ , drift tube length;  $L$ , ion drift length;  $td$ , ion drift time. Reprinted from *The Analyst*, **127**, Tong H, Sze N, Thomson B, Nacsonc S, Pawliszyn J, Solid phase microextraction with matrix assisted laser desorption/ionisation introduction to mass spectrometry and ion mobility spectrometry, page 1208, Figure 1, Copyright (2002). Reproduced by permission of The Royal Society of Chemistry.

immersed in homogeneous chopped solutions of different fruits (apple, grapes, oranges and tomatoes) for 120 min with continuous stirring at 1000 rpm. Then the pesticides were desorbed from the fiber with 100  $\mu$ l of methanol by sonication for 15 min. After desorption, the solutions were injected with running buffer and quantitatively analysed with the SIM-MS method, recording several ions simultaneously and using external calibration. The sensitivity of the method is about 0.2–0.3 mg  $l^{-1}$  depending of the pesticide. The method is not highly sensitive, but is a possible alternative for residue analysis. Recent analytical developments also focused on the miniaturization of laboratory scale instruments and the construction of fieldable systems.<sup>210</sup> Such systems are highly desirable for *in situ* analysis of trace level constituents in air or water. Methods that are so rapid and also provide some degree of preconcentration are highly desirable. Membrane introduction mass spectrometry (MIMS) using a miniaturized mass spectrometer selectively concentrates analytes from the matrix by hydrophobic interactions at the surface followed by selective diffusion and evaporation of the analytes from the membrane surface directly into the high vacuum of the mass spectrometer.<sup>211</sup> SPME fibre introduction mass spectrometry (FIMS) was introduced to avoid the disadvantages of MIMS systems (complicated design with non-commercial instrument parts).<sup>212</sup> FIMS extraction uses commercially available SPME fibres (usually PDMS) and is suited to coupling directly to a small mass spectrometer. The extraction technique is suitable for the effective extraction of volatile and semivolatile organic compounds (VOCs, SVOCs) and allowed simple introduction and thermal desorption directly into the ionization region.<sup>213</sup> Cook's group has developed a portable miniature mass spectrometer (17 kg, including batteries).<sup>213</sup> This small unit was used for the quantitative determination of VOCs and SVOCs using

FIMS (3–5 min extraction time) from aqueous solutions at the low  $\mu$ g  $l^{-1}$  level.

## CONCLUSIONS

SPME is becoming widely used as an extraction and concentration step prior to MS analysis. It affords a number of advantages in simplifying sample preparation, increasing reliability, selectivity, sensitivity and reducing the cost and time of analysis. The majority of early applications were encountered in environmental applications for screening and semi-quantitative purposes. Recent papers have described the use of SPME in various fields of analytical MS, including quantitation. Fibre SPME for the extraction of volatile components from HS is most widely used and novel derivatization procedures may further extend the utility of this technique. The versatility of fibre SPME is enhanced by the possibility of direct insertion into the sample matrix for the analysis of less volatile components. Significant benefits may be gained this way; however, direct insertion methods often require sample agitation and require longer extraction times than HS methods. For the analysis of biological fluids a so-called 'in-tube SPME' extraction technique is gaining ground, which can be easily coupled to HPLC/MS. Owing to its selectivity and high speed of analysis, this may have potential use in combinatorial synthesis, screening and other areas of drug monitoring. The reliability and reproducibility of the technique are further enhanced by the use of commercially available autosamplers for fibre SPME and for in-tube SPME, which opens the way to high-throughput applications. The current development of a wide range of selective, sensitive and stable fibres, which give less background, will further extend the scope of MS applications. Carboxenes, chirally active phases (such as modified cyclodextrins), ion exchangers, HPLC stationary phase particles and sol-gel porous silicas are expected to become available in the near future. With the development of more sensitive fibres further miniaturization may be possible, including the possibility of using SPME as a direct sample introduction device for portable mass spectrometers.

## REFERENCES

1. Smith RM. *J. Chromatogr. A* 2003; **1000**: 3.
2. Pawliszyn J. *Anal. Chem.* 2003; **75**: 2543.
3. Belardi RG, Pawliszyn J. *Water Pollut. Res. J. Can.* 1989; **24**: 179.
4. Arthur CL, Pawliszyn J. *Anal. Chem.* 1990; **62**: 2145.
5. Kataoka H, Lord HL, Pawliszyn J. *J. Chromatogr. A* 2000; **880**: 35.
6. *Science Citation Index* May 2003.
7. Pawliszyn J. *Solid Phase Microextraction: Theory and Practice*. Wiley-VCH: New York, 1998.
8. Pawliszyn J. *Applications of Solid Phase Microextraction*. Royal Society of Chemistry: Cambridge, 1999.
9. Wercinski SCS. *Solid Phase Microextraction—A Practical Guide*. Marcel Dekker: New York, 1999.
10. Pawliszyn J. *Trends Anal. Chem.* 1995; **14**: 113.
11. Eisert R, Levsen K. *J. Chromatogr. A* 1996; **733**: 143.
12. Ulrich S. *J. Chromatogr. A* 2000; **902**: 167.
13. Mills GA, Walker V. *J. Chromatogr. A* 2000; **902**: 267.
14. Chen J, Pawliszyn J. *Anal. Chem.* 1995; **67**: 2530.
15. Gorecki T, Yu XM, Pawliszyn J. *Analyst* 1999; **124**: 643.

16. Wooten JV, Ashley DL, Calafat AM. *J. Chromatogr. B* 2002; **772**: 147.
17. Vas G, Gal L, Dobo A, Vekey K. *J. Chromatogr. Sci.* 1998; **36**: 505.
18. Kolb B, Ettre L. *Static Headspace-Gas chromatography: Theory and Practice*. Wiley-VCH: Weinheim, 1997.
19. Pan L, Pawliszyn J. *Anal. Chem.* 1997; **69**: 196.
20. Lord LH, Grant RP, Walles M, Incledon B, Fahie B, Pawliszyn J. *Anal. Chem.* 2003; **75**: 5103.
21. Lord LH, Walles M, Grant RP, Incledon B, Fahie B, Pawliszyn J. presented at the 51st Conference on Mass Spectrometry and Allied Topics, Montreal, June 2003.
22. Wu J, Lord HL, Pawliszyn J. *Talanta* 2001; **54**: 655.
23. Wu J, Pawliszyn J. *J. Chromatogr. A* 2001; **909**: 37.
24. Kuuranne T, Kotiaho T, Pedersen-Bjeergard S, Rasmussen KE, Leinonen A, Westwood S, Kostianen R. *J. Mass Spectrom.* 2003; **38**: 16.
25. Jonsson OB, Nordlöf U, Nilsson UL. *Anal. Chem.* 2003; **75**: 3506.
26. Mullet WM, Levsen K, Borlak J, Wu J, Pawliszyn J. *Anal. Chem.* 2002; **74**: 1695.
27. Kataoka H. *Anal. Bioanal. Chem.* 2002; **373**: 31.
28. Saito Y, Jinno K. *J. Chromatogr. A* 2003; **1000**: 53.
29. Saito Y, Kawazoe M, Hayashida M, Jinno K. *Analyst* 2000; **125**: 807.
30. Morishima Y, Fujimoto C, Takeichi T, Jinno K, Saito Y. *Chromatographia* 2002; **56**: 585.
31. Saito Y, Nojiri M, Imaizumi M, Nakao Y, Morishima Y, Kanehara H, Matsuura H, Kotera K, Wada H, Jinno K. *J. Chromatogr. A* 2002; **975**: 105.
32. Saito Y, Jinno K. *Anal. Bioanal. Chem.* 2002; **373**: 325.
33. Imaizumi M, Saito Y, Hayashida M, Takeichi T, Wada H, Jinno K. *J. Pharm. Biomed. Anal.* 2003; **30**: 1801.
34. Baltussen E, Sandra P, David F, Cramers C. *J. Microcol. Sep.* 1999; **10**: 737.
35. Buchholz K, Pawliszyn J. *Anal. Chem.* 1994; **66**: 160.
36. Liebich HM, Gesele E, Wöll J. *J. Chromatogr. B* 1998; **713**: 427.
37. Pan L, Chong M, Pawliszyn J. *J. Chromatogr. A*, 1997; **773**: 249.
38. Mester Z, Pawliszyn J. *J. Chromatogr. A* 2000; **873**: 129.
39. Okeyo P, Rentz SM, Snow NH. *J. High Resolut. Chromatogr.* 1997; **20**: 129.
40. Gmeiner G, Krassing C, Schmid E, Tausch H. *J. Chromatogr. B* 1998; **705**: 132.
41. Martos PA, Pawliszyn J. *Anal. Chem.* 1998; **70**: 2311.
42. Nagasawa N, Yashiki M, Iwasaki Y, Hara K, Kojima T. *Forensic Sci. Int.* 1996; **78**: 95.
43. *A Practical Guide to Quantitation with SPME*. Supelco Bulletin 929 T: 101929, 2001. Supelco: Bellefonte, PA.
44. Fattore E, Benfenati E, Fanelli R. *J. Chromatogr. A* 1996; **737**: 85.
45. Stack MA, Fitzgerald G, O Connell S, James JK. *Chemosphere* 2000; **41**: 1821.
46. Abalos M, Prieto X, Bayona JM. *J. Chromatogr. A* 2002; **963**: 249.
47. Lambropoulou DA, Sakkas VA, Albanis TA. *Anal. Chim. Acta* 2002; **468**: 171.
48. Diaz A, Ventura F, Galceran MT. *Anal. Chem.* 2002; **74**: 3869.
49. Diaz A, Ventura F, Galceran MT. *J. Chromatogr. A* 2002; **963**: 159.
50. Tombesi NB, Freije H. *J. Chromatogr. A* 2002; **963**: 179.
51. Tamiri T. Presented at the 51st Conference on Mass Spectrometry and Allied Topics, Montreal, June 2003.
52. Sarrion MN, Santos FJ, Galceran MT. *J. Chromatogr. A* 1999; **839**: 159.
53. Navalon A, Prieto A, Araujo L, Vilchez JL. *J. Chromatogr. A* 2002; **946**: 239.
54. Moeder M, Schrader S, Winkler M, Popp P. *J. Chromatogr. A* 2000; **873**: 95.
55. Zhang Z, Pawliszyn J. *Anal. Chem.* 1993; **65**: 1843.
56. Zhang Z, Pawliszyn J. *Anal. Chem.* 1995; **67**: 34.
57. James KJ, Stack MA. *J. High Resolut. Chromatogr.* 1996; **19**: 515.
58. Moens L, Smaele TD, Dams R, Broeck PVD, Sandra P. *Anal. Chem.* 1997; **69**: 1604.
59. Cai Y, Bayona JM. *J. Chromatogr. A* 1995; **696**: 113.
60. Rodil R, Carro AM, Lorenzo RA, Abuin M, Cela R. *J. Chromatogr. A* 2002; **963**: 313.
61. Barshick CM, Barshick SA, Britt PF, Lake DA, Vance MA, Walsh EB. *Int. J. Mass Spectrom.* 1998; **178**: 31.
62. Davoli E, Gangai ML, Morselli L, Tonelli D. *Chemosphere* 2003; **51**: 357.
63. Sarrion MN, Santos FJ, Galceran MT. *J. Chromatogr. A* 1998; **819**: 197.
64. Santos FJ, Sarrion MN, Galceran MT. *J. Chromatogr. A* 1997; **771**: 181.
65. Fromberg A, Nilsson T, Larsen BL, Montanarella L, Facchetti S, Madsen JO. *J. Chromatogr. A* 1996; **746**: 71.
66. Svendsen MR, Glastrup J. *Atmos. Environ.* 2002; **36**: 3909.
67. De Angelis F. *21st Informal Meeting on Mass Spectrometry*, May 11–15 2003, Antwerp, Book of Abstracts; 69.
68. Hook GL, Kim GL, Hall T, Smith PA. *Trends Anal. Chem.* 2002; **21**: 534.
69. Tuduri L, Desauziers V, Fanlo JL. *J. Chromatogr. A* 2002; **963**: 49.
70. Pino V, Ayala JH, Afonso AM, Gonzalez V. *Anal. Chim. Acta* 2003; **477**: 81.
71. Zhang Z, Pawliszyn J. *J. High Resolut. Chromatogr.* 1993; **16**: 689.
72. Doong RA, Chang SM, Sun YC. *J. Chromatogr. A* 2000; **879**: 177.
73. Penalver A, Pocerull E, Borull F, Marce RM. *J. Chromatogr. A* 1999; **839**: 253.
74. Natangelo M, Tavazzi S, Fanelli R, Benfenati E. *J. Chromatogr. A* 1999; **859**: 193.
75. Eisert R, Levsen K. *J. Am. Soc. Mass Spectrom.* 1995; **6**: 1119.
76. Müller L, Fattore E, Benfenati E. *J. Chromatogr. A* 1997; **791**: 221.
77. Ribeiro A, Neves MH, Almeida MF, Alves A, Santos L. *J. Chromatogr. A* 2002; **975**: 267.
78. Luks-Betlej K, Popp P, Janoszka B, Paschke H. *J. Chromatogr. A* 2001; **938**: 93.
79. Penalver A, Pocerull E, Borrull F, Marce RM. *J. Chromatogr. A* 2000; **872**: 191.
80. Popp P, Kalbitz K, Oppermann G. *J. Chromatogr. A* 1994; **687**: 133.
81. Boyd-Boland AA, Magdic S, Pawliszyn J. *Analyst* 1996; **121**: 929.
82. Tutschku S, Mothes S, Wennrich R. *Fresenius' J. Anal. Chem.* 1996; **354**: 587.
83. Boyd-Boland AA, Pawliszyn J. *Anal. Chem.* 1996; **68**: 1521.
84. Laha S, Luthy RG. *Environ. Sci. Technol.* 1990; **24**: 363.
85. Kataoka H. *J. Chromatogr. A* 1996; **733**: 19.
86. Lu CS, Huang SD. *J. Chromatogr. A* 1995; **696**: 201.
87. Cavallaro A, Piangerelli V, Nerini F, Cavalli S, Reschiotto C. *J. Chromatogr. A* 1995; **709**: 361.
88. *Fed. Reg. EPA Method 604, Phenols Part VIII, 40 CFR Part 136*. US EPA: Washington, DC, 16 October 1984; 58.
89. Llompарт M, Lourido M, Landin P, Garcia-Jares C, Cela R. *J. Chromatogr. A* 2002; **963**: 137.
90. Sarrion MN, Santos FJ, Moyano E, Galceran MT. *Rapid Commun. Mass Spectrom.* 2003; **17**: 39.
91. Penalver A, Pocerull E, Borrull F, Marce RM. *J. Chromatogr. A* 2001; **922**: 377.
92. Wu FW, Gabryelski W, Froese K. *Analyst* 2002; **127**: 1318.
93. Magdic S, Boyd-Boland AA, Jinno K, Pawliszyn J. *J. Chromatogr. A* 1996; **736**: 219.
94. Zambonin CG, Palmisano F. *J. Chromatogr. A* 2000; **874**: 247.
95. Reyzer ML, Brodbelt JS. *Anal. Chim. Acta* 2001; **436**: 11.
96. Gerecke AC, Tixier C, Bartels T, Schwarzenbach RP, Muller SR. *J. Chromatogr. A* 2001; **930**: 9.
97. Hwang BH, Lee MR. *J. Chromatogr. A* 2000; **898**: 245.
98. Salafranca J, Batlle R, Nerin C. *J. Chromatogr. A* 1999; **864**: 137.
99. Lee MR, Yeh YC, Hsiang WS, Chen CC. *J. Chromatogr. B* 1998; **707**: 91.
100. Takamoto S, Sakura N, Yashiki M, Kojima T. *J. Chromatogr. B* 2001; **758**: 123.
101. Kusakabe T, Saito T, Takeichi S. *J. Chromatogr. B* 2001; **761**: 93.
102. Sakkas VA, Lambropoulou DA, Sakellarides TM, Albanis TA. *Anal. Chim. Acta* 2002; **467**: 233.

103. Delzer GC, Zogorski JS, Lopes TJ, Bosshart RJ. *Water Resources Investigations Report 96-4145*. US Geographical Survey: Denver, CO., 1996.
104. Achten C, Kolb A, Puttmann W. *Atmos. Environ.* 2001; **35**: 6337.
105. Piazza F, Barbieri A, Violante FS, Roda A. *Chemosphere* 2001; **44**: 539.
106. Zuccarello JL, Ganske JA, Green DB. *Chemosphere* 2003; in press.
107. Holdak M, Tesniarz D, Wojtasik E, Polec-Pawlak K, Jarosz M. *21st Informal Meeting on Mass Spectrometry*, May 11–15 2003. Antwerp, Book of Abstracts; 71.
108. Szostek B, Aldstadt JH. *J. Chromatogr. A* 1998; **807**: 253.
109. Killelea DR, Aldstadt JH. *Chemosphere* 2002; **48**: 1003.
110. Wu J, Mester Z, Pawliszyn J. *Anal. Chim. Acta* 2000; **424**: 211.
111. Yang L, Colombini V, Maxwell P, Mester Z, Sturgeon RE. *J. Chromatogr. A* 2003; **1011**: 135.
112. Yamada H, Takayanagi K, Tateishi M, Tagata H. *Environ. Pollut.* 1997; **96**: 217.
113. Bancon-Montigny C, Maxwell P, Yang L, Mester Z, Sturgeon RE. *Anal. Chem.* 2002; **74**: 5606.
114. Vas G, Lorincz G. *Acta Aliment.* 1999; **28**: 95.
115. Vas G, Koteleky K, Farkas M, Dobo A, Vekey K. *Am. J. Enol. Vitic.* 1998; **49**: 100.
116. Yang XG, Peppard T. *J. Agric. Food Chem.* 1994; **42**: 1925.
117. Miklosy E, Kalmar Z, Polos V, Kerenyi Z. *Chromatographia* S2000; **51**: S305.
118. Freitas AMC, Parreira C, Vilas-Boas L. *J. Food Comp. Anal.* 2001; **14**: 513.
119. Harangi J, Vas Gy. Identification of GC peaks—identification of GC chromatograms. *20th International Symposium on Capillary Chromatography, Riva del Garda, Italy, 25–29 May, 1998 Book of Abstracts CD-ROM Poster No. A11*.
120. Augusto F, Valente ALP, Tada ES, Rivellino SR. *J. Chromatogr. A* 2000; **873**: 117.
121. Jirovetz L, Buchbauer G, Ngassoum MB, Geissler M. *J. Chromatogr. A* 2002; **976**: 265.
122. Stanfill SB, Calafat AM, Brown CR, Polzin GM, Chiang JM, Watson CH, Ashley DL. *Food Chem. Toxicol* 2003; **41**: 303.
123. Pinho O, Ferreira IMPLVO, Ferreira MVA. *Anal. Chem.* 2002; **74**: 5199.
124. Pinho O, Peres C, Ferreira IMPLVO. *J. Chromatogr. A* 2003; **1011**: 1.
125. Wan XM, Stevenson RJ, Chen XD, Melton LD. *Food Res. Int.* 1999; **32**: 175.
126. Vas Gy, Kozma P, Lialios A, Harangi J, Dobó A, Vékey K. *19th International Symposium on Capillary Chromatography and Electrophoresis, Wintergreen, USA 18–22 May 1997 proc.* 644–645.
127. Vas Gy, Kozma P, Lialios A, Harangi J, Dobó A, Vékey K. *14th International Mass Spectrometry Conference, 25–29 August 1997, Tampere, Finland, Book of Abstracts*; 260.
128. Shang C, Hu Y, Deng C, Hu K. *J. Chromatogr. A* 2002; **942**: 283.
129. Kim NS, Lee DS. *J. Chromatogr. A* 2002; **982**: 31.
130. Paliyath G, Whiting MDR, Stasiak MD, Murr DP, Clegg BS. *Food Res. Int.* 1997; **30**: 95.
131. Perera RMM, Mariott PJ, Galbally IE. *Analyst* 2002; **127**: 1601.
132. Elmore JS, Mottram DS, Hierro E. *J. Chromatogr. A* 2000; **905**: 233.
133. Mitani K, Narimatsu S, Kataoka H. *J. Chromatogr. A* 2003; **986**: 169.
134. Navalon A, Prieto A, Araujo L, Vilchez JL. *J. Chromatogr. A*, 2002; **975**: 355.
135. Ahmed EF. *Trends Anal. Chem.* 2001; **20**: 649.
136. Wu J, Tragas C, Lord H, Pawliszyn J. *J. Chromatogr. A* 2002; **976**: 357.
137. Hu RW, Hennion B, Urruty L, Montury M. *Food Addit. Contam.* 1999; **16**: 111.
138. Ezquerro O, Pons B, Tena MT. *J. Chromatogr. A*, 2002; **963**: 381.
139. Khabbaz F, Albertsson AC, Karlsson S. *Polym. Degrad. Stab.* 1999; **63**: 127.
140. Ezquerro O, Pons B, Tena MT. *J. Chromatogr. A* 2003; **985**: 247.
141. Jelen HH, Wlazly K, Wasowicz E, Kaminski E. *J. Agric. Food Chem.* 1998; **46**: 1469.
142. Pino J, Marti MP, Mestres M, Perez J, Busto O, Guasch J. *J. Chromatogr. A*, 2002; **954**: 51.
143. Vas Gy. *Supelco Rep.* 1997; **16**(4): 7.
144. Ebeler SE. *Food Rev. Int.* 2001; **17**: 45.
145. Evans TJ, Butzke CE, Ebeler SE. *J. Chromatogr. A* 1997; **786**: 293.
146. Luan T, Li G, Zhang Z. *Anal. Chim. Acta* 2000; **424**: 19.
147. Vas G, Blechschmidt I, Kovacs T, Vekey K. *Acta Aliment.* 1999; **28**: 133.
148. Lorincz Gy, Vas Gy. *Vitic. Enol. Sci.* 1997; **53**: 18.
149. Marengo E, Aceto M, Maurino V. *J. Chromatogr. A* 2002; **943**: 123.
150. Favretto D, Grandis G, Allegri G, Traldi P. *Rapid Commun. Mass Spectrom.* 1998; **12**: 1595.
151. Bonino M, Schellino R, Rizzi C, Aigotti R, Delfini C, Baiocchi C. *Food Chem.* 2003; **80**: 125.
152. Garcia DD, Reichenbacher M, Danzer K, Hurlbeck C, Bartsch C, Feller KH. *J. High Resolut. Chromatogr.* 1997; **20**: 665.
153. Garcia DD, Reichenbacher M, Danzer K, Hurlbeck C, Bartsch C, Feller KH. *Fresenius' J. Anal. Chem.* 1998; **360**: 784.
154. Garcia DD, Reichenbacher M, Danzer K, Hurlbeck C, Bartsch C, Feller KH. *J. High Resolut. Chromatogr.* 1998; **21**: 373.
155. Pozo-Bayon MA, Pueyo E, Martin-Alvarez PJ, Polo MC. *J. Chromatogr. A* 2001; **922**: 267.
156. Sala C, Mestres M, Marti MP, Busto O, Guasch J. *J. Chromatogr. A* 2002; **953**: 1.
157. Freire LMTV, Freitas AMC, Relva AM. *J. Microcol. Sep.* 2001; **13**: 236.
158. Begala M, Corda L, Podda G, Fedrigo MA, Traldi P. *Rapid Commun. Mass Spectrom.* 2002; **16**: 1086.
159. Demyttenaere JCR, Dagher C, Sandra P, Kallitharaka S, Verhe R, Kimpe ND. *J. Chromatogr. A* 2003; **985**: 233.
160. Garcia DD, Magnaghi S, Reichenbacher M, Danzer K. *J. High Resolut. Chromatogr.* 1996; **19**: 257.
161. David F, Tienpont B, Sandra P. *LC-GC Eur.* 2003; **16**: 410.
162. Vas G. PerkinElmer chromatography training material for BorsodChem Ltd. Chapter 2. 2001; 28.
163. Jang MS, Cai EN, Udeani GO, Slowing KV, Thomas CF, Beecher CWW, Fong HHS, Farnsworth NR, Kinghorn AD, Mehta RG, Moon RC, Pezzuto JM. *Science* 1997; **275**: 218.
164. Demyttenaere JCR, Martinez JIS, Verhe R, Sandra P, Kallitharaka S, Kimpe ND. *J. Chromatogr. A* 2003; **985**: 221.
165. Volmer DA, Hui JPM. *Rapid Commun. Mass Spectrom.* 1997; **11**: 1926.
166. Dunemann L, Hajimiragha H, Begerow J. *Fresenius' J. Anal. Chem.* 1999; **363**: 466.
167. Guidotti M, Vitali M. *J. High Resolut. Chromatogr.* 1998; **21**: 665.
168. Fustinoni S, Giampiccolo R, Pulvirenti S, Buratti M, Colombi A. *J. Chromatogr. B* 1999; **723**: 105.
169. Bergamaschi E, Brustolin A, De Palma G, Manini P, Mozzoni P, Andreoli R, Cavazzini S, Mutti A. *Toxicol. Lett.* 1999; **108**: 241.
170. Yashiki M, Kojima T, Miyazaki T, Nagasawa N, Iwasaki Y, Hara K. *Forensic Sci. Int.* 1995; **76**: 169.
171. Mills GA, Walker V. *J. Chromatogr. B* 2001; **753**: 259.
172. Centini F, Masti A, Comparini IB. *Forensic Sci. Int.* 1996; **83**: 161.
173. Huang MK, Liu CR, Huang SD. *Analyst* 2002; **127**: 1203.
174. Ugland HG, Krogh M, Rasmussen KE. *J. Pharm. Biomed. Anal.* 1999; **19**: 463.
175. Myung SW, Min HK, Kim S, Kim M, Cho JB, Kim TJ. *J. Chromatogr. B* 1998; **716**: 359.
176. Poli D, Bergamaschi E, Manini P, Andreoli R, Mutti A. *J. Chromatogr. B* 1999; **732**: 115.
177. Staerk U, Külpmann WR. *J. Chromatogr. B* 2000; **745**: 399.
178. Mills GA, Walker V, Mughal H. *J. Chromatogr. B* 1999; **723**: 281.
179. Hall BJ, Brodbelt JS. *J. Chromatogr. A* 1997; **777**: 275.
180. Felix T, Hall BJ, Brodbelt JS. *Anal. Chim. Acta* 1998; **371**: 195.
181. Myung SW, Kim M, Min HK, Yoo EA, Kim KR. *J. Chromatogr. B* 1999; **727**: 1.
182. Satterfield M, Black DM, Brodbelt JS. *J. Chromatogr. B* 2001; **759**: 33.

183. Kataoka H, Lord HL, Pawliszyn J. *J. Chromatogr. B* 1999; **731**: 353.
184. Takayama N, Tanaka S, Hayakawa K. *Biomed. Chromatogr.* 1997; **11**: 25.
185. Liu JT, Hara K, Kashimura S, Hamanaka T, Tomojiri S, Tanaka K. *J. Chromatogr. A* 1999; **731**: 217.
186. Namera A, Yashiki M, Nagasawa N, Iwasaki Y, Kojima T. *Forensic Sci. Int.* 1997; **88**: 125.
187. Mullett WM, Levsen K, Lubda D, Pawliszyn J. *J. Chromatogr. A* 2002; **963**: 325.
188. Lee MR, Song YS, Hwang BH, Chou CC. *J. Chromatogr. A* 2000; **896**: 265.
189. Namera A, Yashiki M, Liu J, Okajima K, Hara K, Imamura T, Kojima T. *Forensic Sci. Int.* 2000; **109**: 215.
190. Okajima K, Namera A, Yashiki M, Tsukue I, Kojima T. *Forensic Sci. Int.* 2001; **116**: 15.
191. Watanabe T, Namera A, Yashiki M, Iwasaki Y, Kojima T. *J. Chromatogr. B* 1998; **709**: 225.
192. Walles M, Mullett WM, Levsen K, Borlak J, Wünsch G, Pawliszyn J. *J. Pharm. Biomed. Anal.* 2002; **30**: 307.
193. Sporkert F, Pragst F. *Forensic Sci. Int.* 2000; **107**: 129.
194. Gentili S, Torresi A, Marsili R, Chiarotti M, Macchia T. *J. Chromatogr. B* 2002; **780**: 183.
195. Liu JT, Hara K, Kashimura S, Kashiwagi M, Kageura M. *J. Chromatogr. B* 2001; **758**: 95.
196. Sporkert F, Pragst F. *J. Chromatogr. B* 2000; **746**: 255.
197. Pragst F, Spiegel K, Sporkert F, Bohnenkamp M. *Forensic Sci. Int.* 2000; **107**: 201.
198. Hartwig S, Auwarter V, Pragst F. *Forensic Sci. Int.* 2003; **131**: 90.
199. Boyle RR, McLean S, Brandon S, Pass GJ, Davies NW. *J. Chromatogr. B* 2002; **780**: 397.
200. Spinhirne JP, Koziel JA, Chirase NK. *Biosyst. Eng.* 2003; **84**: 239.
201. Prado C, Marin P, Periago JF. *J. Chromatogr. A* 2003; **1011**: 125.
202. Jelen HH. *Lett. Appl. Microbiol.* 2003; **36**: 263.
203. Nilsson T, Larsen TO, Montanarella L, Madsen JO. *J. Microbiol. Methods* 1996; **25**: 245.
204. Lloyd SW, Lea JM, Zimba PV, Grimm CC. *Water Res.* 1998; **32**: 2140.
205. Wady L, Bunte A, Pehrson C, Larsson L. *J. Microbiol. Methods* 2003; **52**: 325.
206. Zhu PL, Liu CL, Liu MC. *J. Chromatogr. A* 2003; **988**: 25.
207. Tong H, Sze N, Thomson B, Nacson S, Pawliszyn J. *Analyst* 2002; **127**: 1207.
208. Walles M, Tong H, Thomson B, Nacson S, Pawliszyn J. presented at the 51st Conference on Mass Spectrometry and Allied Topics, Montreal, June 2003.
209. Rodriguez R, Manes J, Pico Y. *Anal. Chem.* 2003; **75**: 452.
210. Pillinger C. Beagle 2—Searching for life on Mars. 16th International Mass Spectrometry Conference, 30 August–5 September 2003, Edinburgh, UK, plenary lecture.
211. Ketola RA, Kotiaho T, Cisper ME, Allen TM. *J. Mass Spectrom.* 2002; **37**: 457.
212. Meurer EC, Tomazela DM, Silva RC, Augusto F, Eberlin MN. *Anal. Chem.* 2002; **74**: 5688.
213. Riter LS, Meurer EC, Rodriguez IC, Eberlin MN, Cooks RG. *Analyst* 2003; **128**: 1119.