

SOLID-STATE MARX BANK MODULATOR FOR THE NEXT LINEAR COLLIDER*

Jeffrey A. Casey, Floyd O. Arntz, Marcel P.J. Gaudreau, Michael A. Kempkes
 Diversified Technologies, Inc. Bedford, MA 01730 USA

Abstract

In this paper, we will discuss the design of a solid-state Marx Bank modulator (Figure 1) for the NLC, which will deliver 150 ns risetime (10-90%) for a 500 kV, 530 A pulse (for two klystrons), with efficiency over 90%. The use of a common mode inductive charging system allows transfer of filament power without separate isolation transformers. The combination of these features supports future compact, inexpensive, very high voltage pulsed power systems.

eliminate the need for a pulse transformer, and its attendant ~10% efficiency penalty. As a result of these efforts, the Marx Bank architecture (Figure 2) has emerged as the leading approach to meeting the NLC requirements. DTI has built several prototype Marx Banks capable of full NLC current and 5-10% voltage capability, with significantly improved risetime, and excellent flattop performance. We have begun the implementation of a 2-klystron test stand of this architecture, which will result in delivery of a full-scale prototype to SLAC in 2006.

INTRODUCTION

The Next Generation Linear Collider (NLC) will require more than 4000 klystrons as RF drivers. These klystrons will, in turn, require 500 kV 265A pulses of 1.6 μ s duration. The scope of this power system is such that small changes in power efficiency can enable ten year operating cost savings comparable to the capital equipment cost of the power systems themselves.

Under a series of SBIR grants from the DOE, DTI has been developing solid state modulator topologies which

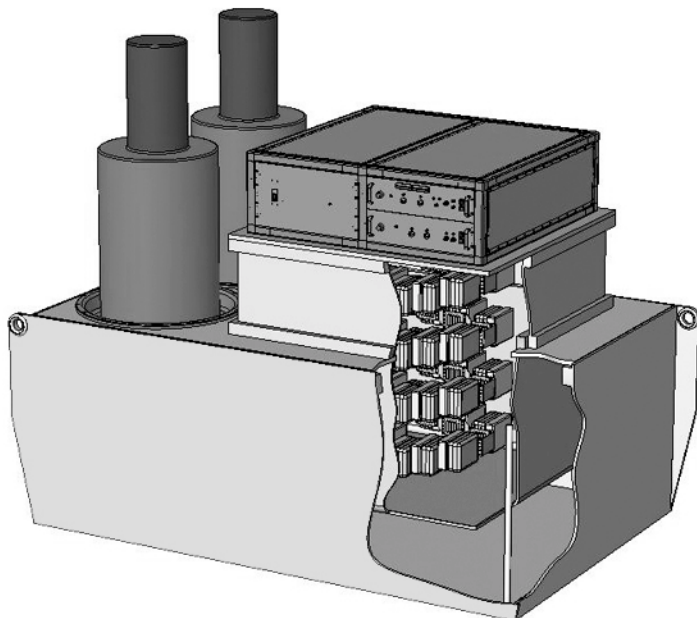

Figure 1. Solid model of NLC two-klystron Marx switch, suspended from control and power panels, inserted in re-entrant air-insulated chamber in oil tank.

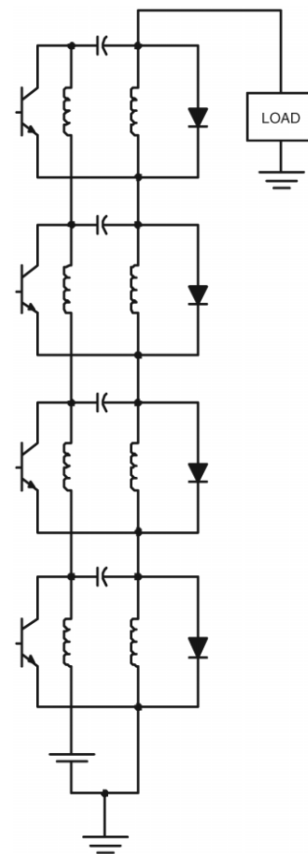

Figure 2. The modern Marx Bank switch. The energy storage capacitors are charged through the common mode chokes during the inter-pulse period. When the switches conduct, the capacitors are assembled in series to erect the high voltage discharge. The shunt diodes allow the switches to stagger their firing delays.

*Work supported in part by the US Dept of Energy under grants DE-FG02-03ER83638, DE-FG02-02ER82775, and DE-FG02-02ER83396.

DESIGN

The key element of the NLC Marx System is the use of modern solid-state devices (insulated gate bipolar transistors, or IGBTs) as switching elements. These have the ability to open under full load current, so the Marx Bank can deliver a short flat-top pulse and open without appreciably depleting the energy storage capacitor bank. This allows the voltage droop during the discharge to be fully defined by selection of the storage capacitor sizing.

Another break from traditional Marx Bank usage is the circuit utilized for recharge of the energy storage capacitors. Traditionally, the capacitors are charged during the inter-pulse period through bleed resistors or blocking inductors, requiring design tradeoffs which limit pulse repetition rate. This design recharges through a common-mode choke, which provides both a low-impedance recharge path and a high degree of common-mode blocking during the pulse period. The common mode choke also provides an easy path to provide klystron filament power and power to each of the gate drives, without the use of an isolation transformer.

One further circuit feature is the use of a properly sized freewheeling shunt diode, which is capable of passing full pulse current if the corresponding switch is not fired. We take advantage of this feature to add additional stages which are fired at staggered delay intervals during the pulse. In this way, the size of the capacitor bank can be significantly reduced – to such a level that the droop would otherwise fail the flat-top specification. Staggered firing of the additional stages results in a sawtooth waveform, refreshing the klystron voltage intra-pulse. Stray and compensation reactances round the tops of the sawteeth, resulting in a low-amplitude cycloidal ripple.

The final key to realizing high efficiency is the reduction of the parasitic capacitance of the full Marx switch assembly. This is achieved through reduction in the physical size of the energy storage capacitors through staggered firing, minimization of the size of the switching elements and support circuitry, and through careful 3D mechanical layout of the assembly. The physical layout of the highest voltage modules are the most critical in this regard, because the parasitic capacitance to ground must be charged to full voltage every cycle, and represents the largest losses in the system.

PROTOTYPE EXPERIMENTS

Several prototype assemblies have been explored in our program to date. Conventional IGBT packaging (either large “brick” assemblies or arrays of TO-247 discretes) were found to be inappropriate for the goal of minimized switch volume. Custom IGBT devices (Figure 3), developed in collaboration with Powerex, were optimized for maximum pulse power per volume, resulting in very compact systems.

A critical factor in the overall design is optimizing the number of Marx modules in the 500 kV system, Single element modules are capable of 2.5 kV and 600 A pulsed current, and have the advantage that the gate drive circuits may be directly coupled to the IGBTs at each stage, but

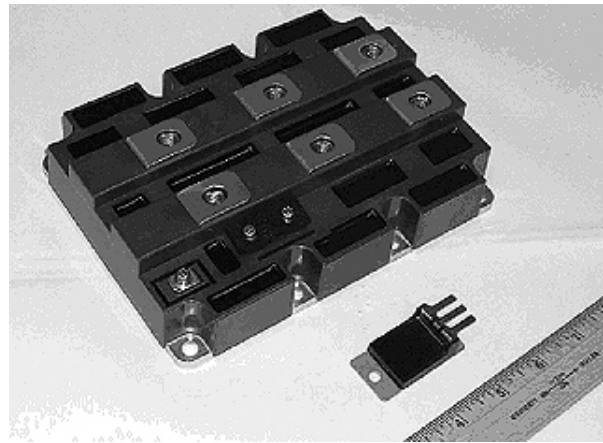

Figure 3. Two packages of 4500 V silicon. The large brick above is a 900 A (continuous) multi-die assembly. The small package below is a single die package of the same silicon dubbed the PPT (pulse power transistor), jointly developed by DTI and Powerex for fast switching at high pulsed power densities.

well over 200 modules must be used, which significantly contributes to the control overhead in the modulator. In addition, prime power at 2.5 kV must deliver moderately large currents, increasing power losses and requiring large gauge recharge conductors. By using series connected IGBTs, modules of arbitrary voltage can be built, reducing the total number of modules required. The optimum design point for the system was analytically and experimentally determined to use about six of the PPT devices in series within each module, making a 15 kV switch of 600 A pulsed current capability. About 35 of these modules are required for the NLC switch. The recharge currents at 15 kV are low, making the prime power supply simple and inexpensive.

Initial testing of the latter (15 kV module) Marx demonstrates the high performance which is achievable. Five stages were charged to 10 kV, and discharged into a 120 Ω load for a 1.25 μ s flat-top pulse. The risetime (0-97%) is about 250-300 ns. Figure 4 shows the load current for this test, with a clean 400 A flat-top for the pulse duration.

FULL SCALE DESIGN

In our extrapolation from prototype to full system, we are taking into account additional second order considerations. These include:

- Ergonomics – overall size, ease of diagnostics and repair,
- MTBF – heat removal, tracking gradients along insulators and enhanced degradation,
- System efficiency – Minimization of losses in power conversions *ex-modulator*.

This last item yields significant returns. Having optimized our Marx Bank at ~15 kV prime power, we do not need to utilize conventional high frequency inverter/transformer power supply design (typically 90%

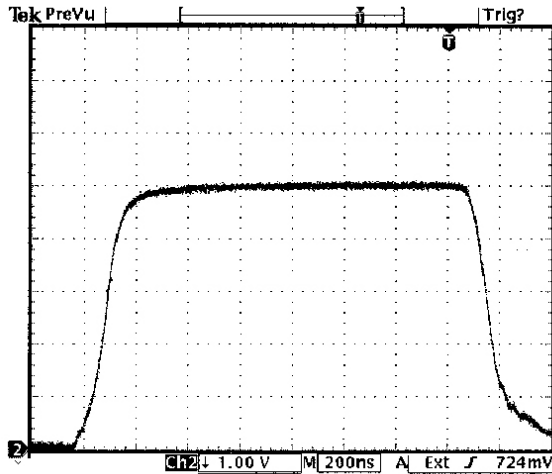

Figure 4. A high power test of 5-stage Marx with 10 kV precharge and 120 Ω load shows a risetime (0-97%) of 250-300 ns. The trace shown is the load current, at 80 A/div.

efficient). Instead, we can directly rectify 13.8 kV utility mains, and use a 98-99% efficient buck regulator to provide our raw power, essentially eliminating one entire step of power conversion loss.

A solid-model design for the compact six-PPT module is shown in Figure 5. This module includes the gate drive, high-side couplings, common mode choke, and diagnostic circuitry in a Faraday shielded enclosure about 6" x 7" x 2". The energy storage capacitor is mounted back-to-back with the enclosure, and is about 6" x 7" x 1.5" (this size is based on quotes from manufacturers, and assumes only conventional poly/film construction with generous packaging allowances). The shunt diode assembly is a board which mounts across the switch/capacitor buswork, forming a triangular circuit block with very low inductance in either switched or bypassed state. All controls are coupled via fiber optics.

The block-modules assemble as a series array onto a

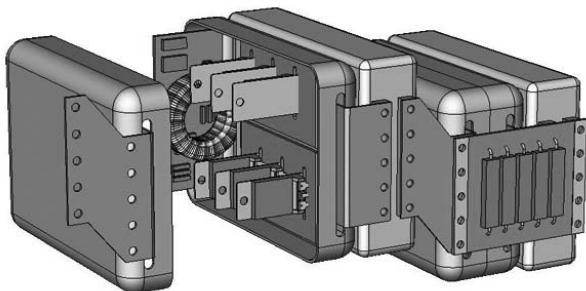

Figure 5. Solid model of the 15 kV Marx module, with buswork and one adjacent neighbor. The interior of the shielded switchbox has 6-PPT pulser, control board, and common-mode choke. Lighter colored capacitor is mounted adjacently. The shunt diode board is mounted externally, across the capacitor and switch unit leads.

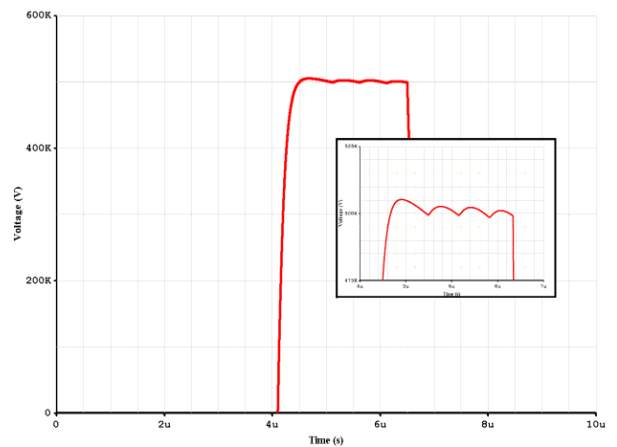

Figure 6. Modeling results of an assembly of 15 kV Marx modules, with physical parasitic capacitance and bus inductance, compensation and additional staggered stages. A very clean flat-top 2 μ s pulse is achieved into a 1.5 μ P (two klystron) load in parallel with 150 pF.

mechanical superstructure which contains the interconnect buswork, and can be easily dismantled for maintenance. The structure is wrapped in a "squashed helix" to maximize the self-shielding effects of neighbors and thus minimize the parasitic capacitance to ground.

Using all of the above optimizations, our models show that the two-klystron switch, with small capacitors and staggered timing, can achieve 89% power efficiency – nearly 10% higher than any other known NLC modulator design. We can fold the physical models for the parasitic capacitance of the structure and the bus inductance of the switch assembly into SPICE models, and show 250-300 ns risetimes, with flat-tops better than +/- 1.0% (Figure 6).

Combined with a highly efficient (98%) buck regulator running off unregulated rectified 13.8 kVAC utility mains, we expect to achieve an overall efficiency of 85% from the utility drop to the useable flat-top klystron beam.

SUMMARY AND CONCLUSIONS

It is clear that the two key parameters for performance of the Marx system are the parasitic capacitance and risetime. The superb performance of the Marx bank modulator in both critical parameters allows us to predict that the modulator efficiency will be of the order of 90%, far higher than any alternative cathode modulator configuration for the NLC. We believe that the Marx bank system offers the optimal combination of cost, efficiency, and operability to the NLC program for cathode pulsed klystrons.

In the next two years, we anticipate the construction and evaluation of a full-scale Marx bank system for the NLC, which can be operated and objectively compared to alternative modulator approaches. As a result of these efforts, we see this Marx schema as an optimal modulator topology for a range of high voltage, short pulse systems.