

SOLID-STATE PULSED-POWER SYSTEMS FOR THE NEXT LINEAR COLLIDER

Marcel P.J. Gaudreau, Jeffrey A. Casey, Ian S. Roth, Timothy J. Hawkey,
J. Michael Mulvaney, Michael A. Kempkes
Diversified Technologies, Inc. 35 Wiggins Ave. Bedford, MA USA

Abstract

The Next Generation Linear Collider (NLC) represents a significant challenge for high voltage modulator technology. The 3200 X-band klystrons that provide RF for the accelerator require 500kV, 265A, and pulses of 1-5 μ s. Given the large number of klystron modulators required, small improvements in modulator efficiency, reliability, and maintainability have significant life-cycle cost impacts.

In 1999, Diversified Technologies, Inc. (DTI) was awarded three Small Business Innovative Research (SBIR) grants from the Department of Energy to assess solid-state switching technology for NLC. These efforts are focused on three modulator configurations: a hybrid modulator, which uses a switch and a pulse transformer, a hard switch, and a Marx bank. This paper describes the architecture, trade-offs, and progress in the development of these solid-state designs, at approximately the midpoint in their development.

1 INTRODUCTION

The Next Linear Collider (NLC) will require approximately 3200 klystrons, operating at 500kV and 265A. The pulse will have a width of 3 μ s, a flattop of $\pm 3\%$, and a pulse repetition frequency of 120Hz.

Not only do these requirements pose a strong technical challenge, but the life-cycle costs of the NLC system depend strongly on the power efficiency. Modeling shows that each percent improvement in efficiency saves \$5M over a 10-year life. Additional key concerns for the system, which will have over one thousand modulators, are reliability and maintainability. NLC and DTI are working on several topologies of solid-state modulator design to address these issues [1,2]

A solid-state modulator is a large series stack of IGBTs or FETs, configured for very high voltage standoff, and operated as a single ideal switch. DTI has over a decade of experience designing and manufacturing these switches. One typical system, installed at Communications and Power Industries (CPI) in Palo Alto for testing of high power gyrotrons and klystrons, operates at voltages of 140kV and currents of 500A.

DTI is presently investigating three solid-state modulator architectures under contract with DOE and SLAC. The first is a hybrid modulator – a solid-state modulator with a pulse transformer. This system is under construction and will be delivered to SLAC for performance testing in early 2002. The other two systems eliminate the pulse transformer for greater efficiency. One

of these is a hard switch; the other is a solid-state Marx bank.

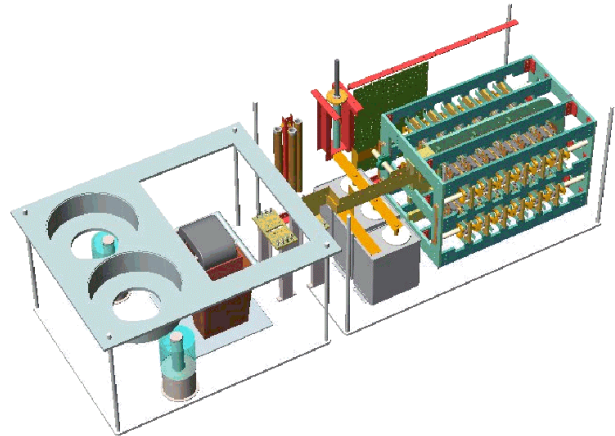

Figure 1. Hybrid system assembly

2 HYBRID

A hybrid design uses a solid-state modulator to drive a pulse transformer, which steps up the voltage to the final output value. An assembly drawing of a hybrid design is shown in Figure 1. The key to effective design of a hybrid system is limiting the inductance in the primary circuit – implied by the high primary currents, low primary voltages, and fast risetimes required. In a previous paper [2], we considered two transformer winding types and a range of transformer ratios. The tradeoff between power efficiency and equipment cost gave a design voltage of 80kV and a transformer ratio of 6.3:1 for a load of two parallel klystrons (1.5 μ Perv total). This results in an 80% wall-plug efficiency for a 3 μ s flattop pulse.

Testing shows that the IGBT and the accompanying plate bus-work and gate-drive circuitry make a suitable switching element. It carries a current of 8 kA (3 kA required) and an inductance of 50-80 nH (100 nH required).

To give a high-quality pulse shape, the energy-storage capacitors, switching elements, and transformer primary windings are connected in a strip-line configuration. The very-high-voltage secondary circuit is made with flying leads from the pulse transformer to the klystrons, since the inductance in the secondary circuit is of little consequence. Circuit-modeling shows that net system efficiency is 80% when the 0-97% risetime is minimized.

We note that the stand-off voltage of available IGBTs has increased from 3300V, at the time we proposed this work, to 4500V at present.

however – the net 10 year cost to NLC of additional stray capacitance on each modulator is \$140k/pF!

3 MODULATORS WITHOUT A TRANSFORMER

There are several drawbacks to the hybrid configuration. The pulse transformer has 5-10% core and magnetization losses; in addition, the power coupled in during the risetime is not usable, and gives a further inefficiency. To increase the system efficiency, we are studying two architectures that do not use transformers, and have a faster risetime than a system that does. The net 10-year result of a 10% increase in efficiency is \$45M at 5¢/kW-h.

The 500-kV standoff voltage, however, poses significant challenges. The control power for DTI switch modules is typically coupled by a single-turn-primary transformer. However, HV standoff and parasitic capacitance preclude using this technique at 500kV. Instead, both systems use a patented technique for powering the gate drive and diagnostic circuits directly from the HV line itself (Figure 4)

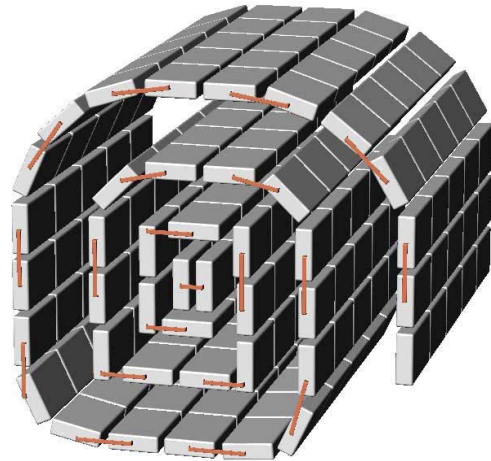

Figure 2. Low capacitance hard switch layout

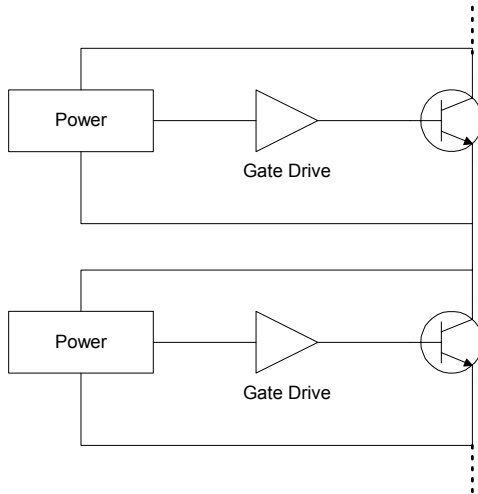

Figure 4. Collector derived gate power

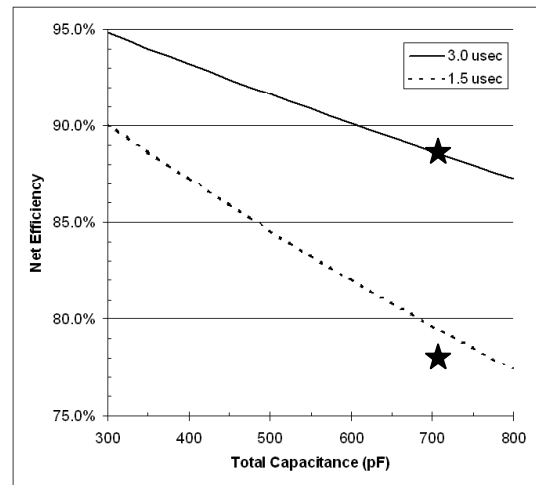

Figure 3. Efficiency versus capacitance

4 HARD SWITCH

One direct switch architecture being considered is a 500-kV hard switch; it is constrained by the system parasitic capacitance. This capacitance can be reduced by wrapping the switching modules about the axis, with the load end of the series stack at the center of the system, shielded by outer modules (Figure 2). The outer layer of the configuration is closest to the 500kV DC end, thus the associated parasitic capacitance is effectively lessened through the smaller charging excursions. Modeling shows that >90% efficiency is possible for a design optimized to power eight klystrons in parallel (Figure 3). This is only possible for very carefully configured switch assemblies

5 MARX BANK

Another direct architecture being investigated is a Marx bank system, first proposed for NLC application by A. Krasnykh et al [3]. A circuit is shown in Figure 5. Similar to the hard switch, the Marx bank does not use a pulse transformer, but directly switches the full system voltage. The main advantage of the Marx architecture over the hard switch is that there is no 500kV DC standoff. This is offset by the requirement of repetitively elevating the larger physical bulk of the energy storage capacitors to pulse voltage and back, thus the system has a higher parasitic capacitance. The challenge to the Marx design is to devise a configuration that takes advantage of the lower system DC voltages to minimize the effects of the parasitic capacitance.

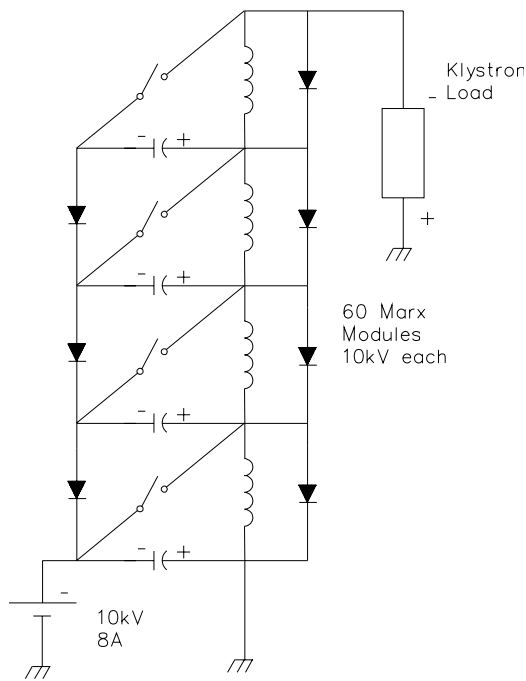

Figure 5. Marx modulator schematic

Our modeling has shown that a stack of thin, hoop-like assemblies (Figure 6) serves this purpose well. The key parasitic capacitance (between each stage and ground) is drastically reduced at the expense of the less-important stage-to-stage capacitance. Parametric surveys show that the overall system performance is optimized around 25-35kV per stage – high enough so that there is redundancy within each high voltage switch assembly and that the recharge currents low, yet low enough so that the *intra-module* parasitic capacitances are negligible.

These results show that 90% efficiency is attainable. A system assembly is shown in Figure 6: it is air insulated, has 16 decks at 32kV per deck, and overall dimensions of about 3'x5'x10'. The use of very flat high energy density energy storage capacitors is key to the success of this – we are currently investigating the designs of metallized-paper capacitors with suppliers.

The key advantage of the Marx bank over a hybrid modulator is a faster risetime, higher efficiency, and a flatter pulse. The tradeoff for this is a higher equipment cost – probably 20%-40% higher.

6 SUMMARY

The following is a summary of the three systems considered.

A hybrid system drives two klystrons. It has low risk, easy maintenance, and a mature architecture. The equipment costs of this system are the lowest of the three cases considered. However, the efficiency is also the lowest, about 80%. The design is complete, and construction is beginning on a prototype, which will be delivered to SLAC at the end of 2001.



Figure 6. Marx modulator layout. 3' x 5' x 10'

The hard-switch system drives eight klystrons. It has the highest efficiency (90%) and good pulse shape, but also has the highest risk and a complicated mechanical structure.

The Marx bank drives one or two klystrons. The risk is low to moderate, maintenance is easy, and the efficiency is high (nearly 90%). The pulse shape is clean, and the life cycle cost may be better than the hybrid.

7 REFERENCES

- [1] Marcel P.J. Gaudreau, Jeffrey A. Casey, J. Michael Mulvaney, Michael A. Kempkes, "Solid State Modulator for Klystron / Gyrotron Conditioning, Testing, and Operation," Conference Record of the 2000 Twenty-Fourth International Power Modulator Symposium, pp.125-8.
- [2] Marcel P.J. Gaudreau, Jeffrey A. Casey, J. Michael Mulvaney, Michael A. Kempkes, "Modulator Development for the Next Generation Linear Collider," *ibid* , pp.153-6.
- [3] A. Krasnykh, R. Akre, S. Gold, and R. Koontz, "A Solid State Marx Type Modulator for Driving a TWT," *ibid*, pp. 209-211.

8 ACKNOWLEDGEMENTS

This work has been supported by DOE SBIR grants (DE-FG02-99ER82775 and DE-FG02-99ER82776); we appreciate the assistance of the Stanford Linear Accelerator Center.