

Solubility and Dissolved Cellulose in Aqueous Calcium- and Sodium-Thiocyanate Solution

Makiko HATTORI, Yoshihiko SHIMAYA, and Masatoshi SAITO

Central Laboratory, Asahi Chemical Industry Co., Ltd.,
11-7 Hacchonawate, Takatsuki, Osaka 569, Japan

(Received June 16, 1997)

ABSTRACT: Attempt was made to investigate the solubility and the dissolved state of various celluloses in aqueous (aq) calcium- and sodium-thiocyanate solution. Almost all celluloses used in this study were soluble in 55 wt% aq calcium thiocyanate ($\text{Ca}(\text{SCN})_2$) soln. at about 100°C, while 60 wt% aq sodium thiocyanate (NaSCN) soln. dissolves only limited cellulose mainly regenerated from cellulose solution. The solubility of cellulose in 60 wt% aq NaSCN was independent of the crystal form, crystallinity and the degree of polymerization of cellulose and this was explained only in terms of the degree of breakdown of intramolecular hydrogen bonds in the cellulose solid. Using 2-dimensional NMR six carbon peaks in ^{13}C NMR spectra of cellulose in two solvents were successfully assigned. The comparison of chemical shifts of cellulose in 55 wt% aq $\text{Ca}(\text{SCN})_2$ solution and 10% sodium hydroxide (NaOH) solution strongly suggested that calcium atoms as electron acceptors coordinate with oxygen atoms in glucose ring and primary alcohol at C(6) position, in the same manner of cellulose dipped in 55 wt% aq $\text{Ca}(\text{SCN})_2$ solution at room temperature. In the ^{13}C NMR spectrum of cellulose–60% aq NaSCN solution system, C(3), C(2), and C(6) peaks were observed at lower magnetic field side, implying that sodium atoms interact with hydroxide groups at C(2), C(3), and C(6) positions of glucopyranose in cellulose molecules.

KEY WORDS Cellulose / Calcium Thiocyanate Solution / Sodium Thiocyanate Solution / Solubility / Hydrogen Bond / Nuclear Magnetic Resonance / Dissolved State /

Recently, cellulose has been attracting attention, because of its natural reproductivity and high biodegradability. But solvents were very limited in metal complexes, strong acids and salts, due to highly developed intra- and intermolecular hydrogen bonds in cellulose solid.¹ For these thirty years, new organic and inorganic solvents, such as *N,N*-dimethylacetamide (DMAc)/lithium chloride (LiCl)^{2,3} and amine oxide containing water,⁴ liquid ammonia/ammonia thiocyanate,^{5,6} and aqueous (aq) sodium hydroxide (NaOH)^{7–9} have been found and the dissolving mechanisms of cellulose into these solvents have been intensively investigated. For some solvents, the solubility of cellulose is exclusively governed by the structure of cellulose solid. For example, natural cellulose can be dissolved in 7–9 wt% aq NaOH solution near 4°C, only when intramolecular hydrogen bonds, estimated by solid state NMR, are destroyed to some extent.^{8,9} Recently, Saito and Shimaya^{10,11} found that concentrated aq sodium thiocyanate (NaSCN) solution at about 100°C is able to dissolve the cellulose regenerated from cellulose solution but not natural cellulose, while aq calcium thiocyanate ($\text{Ca}(\text{SCN})_2$) dissolves both at the same temperature. Relationship between solubility in aq NaSCN soln. and solid structure of cellulose is not known yet. As far as conc. aq $\text{Ca}(\text{SCN})_2$ is concerned, our previous work on its swelling behavior towards natural cellulose at lower temperature region where cellulose could not be dissolved, has revealed that the undissociated $\text{Ca}(\text{SCN})_2$ –water complexes penetrate the amorphous and the interplanar spacings of (1 $\bar{1}$ 0) and (110) crystal plane, forming complexes with ring oxygen and primary alcohol oxygen at C(6) position in glucopyranose ring of cellulose.^{12,13} However, the dissolved state of cellulose in the calcium thiocyanate has not been disclosed.

In this paper attempt is made to obtain more detailed information of the effects of cellulose solid structure on

solubility into aq sodium thiocyanate solution and study the dissolved state of cellulose in aq sodium- and calcium thiocyanate solutions based on the data of two-dimensional NMR.

EXPERIMENTAL

Samples

Several natural and regenerated cellulose samples summarized in the first and second columns of Table I were used for dissolution tests. Conifer pulp (Sample code, CP) is manufactured by Alaska Pulp Co. (U.S.A.) using sulfite pulping method. HP is a hydrolyzed conifer pulp in 25 wt% aq H_2SO_4 for 2 h at 50°C. Commercially available sanitary cotton (Cotton) was supplied from Nankai Sangyou Co. (Osaka). Bacterial cellulose (BC) prepared in our laboratory using *Acetovactor xylinum* and purified¹⁴ was used after washing in water followed by drying. Tunica of *Halocynthia roretzi* was treated by aq 5 wt% KOH and 0.3 wt% NaClO_2 solutions,¹⁵ obtaining purified tunicated cellulose (TC). Among cellulose samples with crystal form II, a sample NOpulp was prepared by dipping conifer pulp into 17.5 wt% aq NaOH soln. for 6 days at room temperature, and CApulp was prepared from HP by dipping into a mixture of cuprammonium solution and 3 wt% aq NaOH solution (1:4, w/w) at 15°C for 1 day, washed with methanol–water (1:1, v/v) mixture, followed by regeneration and removal of remaining copper by dilute hydrochloric acid/methanol solution.

To investigate the effects of the hydrogen bondings in cellulose solid on the solubility against aq sodium thiocyanate solutions, methyl cellulose (MC) with different degrees of substitution $\langle F \rangle$ was prepared: Bemlise[®] (Asahi Chemical Industry, sample code CAR-2) hydrolyzed using 25 wt% aq sulfuric acid was dissolved into 9 wt% aq NaOH soln. to give a 6.5 wt% cellulose so-

Table I. Characteristics of various celluloses and the solubility toward aq Ca(SCN)₂ and NaSCN soln.

Sample code	Resources	Crystal type	Crystallinity	Crystalline size/nm				DP _v	χ _{am} (C ₃)	Solubility	
			%	(110)	(110)	(200)	Mean		%	Ca(SCN) ₂	NaSCN
CP	Conifer pulp	I _β rich	53.8	4.2	4.1	4.0	4.1	970	50	○	×
HP	Hydrolyzed pulp	I _β rich	—	—	—	—	—	425	43	○	×
Cotton	Sanitary cotton	I _β rich	70.5	—	—	—	—	—	39	○	×
BC	Bacterial cellulose	I _β rich	85.0	—	—	—	—	—	33	○	×
TC	Tunicate cellulose	I _β	ca. 90.0	—	—	—	—	—	—	○	×
Rayon	Viscose rayon	II	22.1	—	—	—	—	340	61	○	○
CAF	Regenerated from 55 wt% aq Ca(SCN) ₂	II	41.8	3.2	3.1	3.6	3.3	500	66	○	○
NOI	Regenerated from 9% aq NaOH	II	43.1	3.0	4.5	4.8	4.1	330	—	○	○
OSR	Organic spun rayon	II	45.9	—	—	—	—	600	58	○	○
CAR-1	Cuprammonium rayon fiber	II	38.2	5.0	4.3	4.1	4.5	820	63	○	○
CAR-2	Cuprammonium rayon non-woven fabric	II	18.1	—	—	—	—	870	64	○	○
NOpulp	CP treated by 17.5 wt% aq NaOH & recovered by water	II	30.9	5.0	4.8	5.0	4.9	—	47	○	×
CApulp	IIP treated by cuprammonium & recovered by acetone	I & II	14.9 18.9	4.4 2.7	3.1 3.0	3.8 4.1	3.8 3.3	425	61	○	○

lution.⁷ 3.0 mol of dimethyl sulfate against a glucose unit of cellulose were added to the cellulose solution at 0°C with agitation. The methylation proceeded for desired time from 5 to 60 min. The MC thus synthesized was recovered from reaction media using 10 wt% aq acetic acid soln. and washed in water and water/methanol mixture. «F» of the recovered MC was determined by NMR method using dimethyl sulfoxide-*d*₆ as solvent and was found to be 0.77 (sample code MC1), 1.04 (MC2), 1.65 (MC3), 1.88 (MC4) corresponding to the reaction time 5, 15, 30, 60 min.

Characterization of the Cellulose Samples

Wide angle X-ray diffraction measurements on the cellulose samples in Table I were carried out under the following conditions: Incident beam, Cu-K_α ray; accelerating voltage, 45 kV; beam current, 300 mA. The diffractogram was recorded on a X-ray diffraction instrument RU-300 (Rigaku, Tokyo). Crystallinity χ_c was estimated by peak separation. Apparent crystalline size (ACS) was calculated from half value width of (110), (110), and (200) crystal planes through Scherrer's equation as follows¹⁶:

$$\text{ACS} = 0.9\lambda / (\cos \theta \cdot \beta) \quad (1)$$

$$\beta = (B^2 - b^2)^{1/2} \quad (\text{in Radian}) \quad (2)$$

Where λ is the wave length of the incident beam (0.1542 nm); θ, Bragg's angle; B, half width of the peak for each plane; b, instrumental constant (0.2 degree).

The viscosity-average molecular weight *M_v* was evaluated from the limiting viscosity number [η] of the cellulose sample in cadoxen at 25°C through viscosity equation as follows¹⁷:

$$[\eta] = 3.85 \cdot 10^{-2} \cdot M_w^{0.76} \quad (\text{cm}^3 \text{g}^{-1}) \quad (3)$$

Here, *M_w* is the weight-average molecular weight. The viscosity-average degree of polymerization DP_v was converted from *M_v* obtained.

The degree of breakdown of intramolecular hydrogen bonds (χ_{am}(C₃)) was evaluated from the peak area ratio of C(4) peak in CP/MAS ¹³C NMR spectrum of the each sample, according to the method described in the

literature.⁹ The conditions of NMR were as follows: Instrument, GSX400 (JEOL); flip angle, 90 degree; width, 5 μs; cross-polarization contact time, 1–2 μs; data points, 8192; number of scanning, 512 or 2048 times; external standard, adamantane (upfield peak, δ = 29.5 ppm).

Solubility of Cellulose

A mixture of the cellulose sample and 55 wt% aq calcium- or 60 wt% aq sodium thiocyanate soln. (cellulose/solvent = 0.01/0.99, w/w) was stocked for 1 day at room temperature, followed by heating for 3 h at 120°C with stirring. When the transparent solution was obtained, the sample was judged as dissolved.

Differential Scanning Calorimetry

About 5mg of cellulose or MC samples were loaded in stainless seal cell. DSC measurements were carried out just after ca. 20 mg of 60 wt% aq NaSCN soln. was added to the cellulose or MC samples in the cell. DSC thermograms were recorded on DSC type 200 (Seiko Electronic, Tokyo) with heating rate of 3°C min⁻¹ up to 155°C.

NMR of Cellulose/Ca(SCN)₂- and NaSCN-D₂O Solution Systems

The hydrolyzed Bemlisc® with DP_v = 30 was dissolved in 60 wt% NaSCN/D₂O and 55 wt% Ca(SCN)₂/D₂O solutions at ca. 100°C, giving 1–7 wt% cellulose solutions. The 1 wt% solutions were used for one-dimensional (1D) ¹H NMR measurement, 3 wt% solutions for 1D ¹³C NMR and ¹H-¹³C two dimensional shift correlated NMR (¹H-¹³C COSY) ones and 6 and 7 wt% solutions for ¹³C-¹H two dimensional shift correlated NMR (¹³C-¹H COSY) ones.

NMR measurements were made on a GSX-400 FT-NMR spectrometer (JEOL, Tokyo) at 399.78 MHz for ¹H and 100.54 MHz for ¹³C. ¹H and ¹³C chemical shifts for cellulose were determined from 1D NMR spectra, independently measured, by an internal reference of sodium 3-trimethylsilylpropionate-2,2,3,3-*d*₄ (TSP, 0 ppm), under the following conditions: Spectrum width, 8 kHz for ¹H NMR, 25 kHz for ¹³C NMR; pulse

Table II. Experimental conditions in COSY measurements

Solvent	Cell. conc.	Temp	Pulse Delay	90° pulse width	Spectral width	Data matrix ^a	Accumulation
	wt%	°C	s	μs	Hz		times
55 wt% Ca(SCN) ₂ /D ₂ O	3	100	1.5	20.0	800	2048 × 256 (2048 × 512)	8
60 wt% NaSCN/D ₂ O	3	100	1.5	25.0	800	2048 × 256 (2048 × 512)	8

^a Numbers in parentheses indicate expanded matrixes by zero-filling.

Table III. Experimental conditions for C-H COSY measurements

Solvent	Cell. conc.	Temp	Pulse delay	¹ H 90° Pulse width	¹³ C 90° Pulse width	¹ H Spectral width	¹³ C Spectral width	P13	Data matrix ^a	Accumulation
	wt%	°C	s	μs	μs	Hz	Hz	ms		times
55 wt% Ca(SCN) ₂ /D ₂ O	7	100	2.0	18.9	16.0	800	8000	1.786	2048 × 256 (2048 × 512)	416
60 wt% NaSCN/D ₂ O	6	100	1.5	24.0	15.0	800	6002.4	1.786	2048 × 256 (2048 × 512)	280

^a Numbers in parentheses indicate expanded matrixes by zero-filling.

interval, 3, 2.5 s; pulse width for ¹H NMR, 10 μs (45 degree pulse) for Ca(SCN)₂ system, 12.5 μs (45 degree pulse) for NaSCN system; pulse width for ¹³C NMR, 6 μs; number of accumulation, 8 and 20,000 times for ¹H and ¹³C NMR, respectively.

¹H-¹H COSY and ¹³C-¹H COSY measurements were performed on the same instrument mentioned-above at 100°C. The conditions for both measurements are summarized in Tables II and III. The mixing time P13 for ¹³C-¹H COSY measurements was set up to be 1.786 ms (= 1/(4J_{C-H})), where J_{C-H} is the coupling constant between C and H nuclei.

RESULTS AND DISCUSSION

Solubility of Various Celluloses in aq Calcium and Sodium Thiocyanate

The characteristics and solubility of various celluloses are listed in Table I. The crystal type of natural celluloses was quoted from the literature.¹⁸ The hydrolyzed pulp treated by cuprammonium/NaOH mixture (sample code CAPulp) included cellulose-I and II crystals. The solubility of cellulose against two aq thiocyanate solutions is quite different. 55 wt% aq Ca(SCN)₂ soln. dissolves all kinds of celluloses almost perfectly, irrespective of crystal types, *i.e.*, I_α, I_β, II, crystallinity, ACS and the degree of polymerization of the original cellulose samples. Note here that DP_v of recovered sample CP from the solution, prepared at 120°C for 4 h, was 779. This value is only 20% less than that of the sample CP before dissolution, indicating that dissolution of cellulose into 55 wt% aq Ca(SCN)₂ soln. does not occur by hydrolysis.

60 wt% NaSCN soln. does not dissolve and even swell the treated and untreated natural cellulose. But it gives almost completely transparent solution for the cellulose regenerated from the solution and the cellulose with both crystal forms I and II (CAPulp). Their solubility is at least independent of χ_c and DP_v. 60 wt% aq NaSCN cannot dissolve the cellulose with crystal form II,

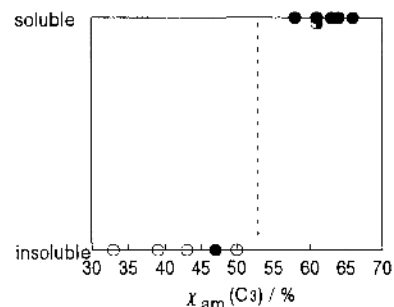

Figure 1. Relationship between the solubility of the samples in Table I against 60 wt% aq NaSCN soln. and χ_{am}(C3). ○, cellulose I; ●, cellulose II; ◐, mixture of celluloses I and II.

obtained by alkali treatment (NOpulp). These facts suggest that crystal form is not a decisive factor controlling solubility toward aq NaSCN. It should be noted that increase in the solubility of the CAPulp, comparing to hydrolyzed pulp (sample HP), is not related to the degree of polymerization, because DP_v is almost invariable after treatment of cuprammonium/NaOH mixture.

Figure 1 shows the relationship between the solubility in aq NaSCN and degree of breakdown of intramolecular hydrogen bonds of C(3)-OH...O(5') [χ_{am}(C3)] for the samples. In the figure filled and unfilled circles denote the cellulose with crystal forms II and I, respectively, and a half-filled circle denotes the cellulose with celluloses I and II crystals. The effect of intramolecular hydrogen bondings on the solubility is remarkable, as has been proved for cellulose solubility in 9% aq NaOH soln.⁹ Soluble-insoluble border seems to be about 55% of χ_{am}(C3) (broken line). This value is almost the same in the case of NaOH system.⁹ χ_{am}(C3) might also reflect the degree of breakdown of intermolecular hydrogen bonds since there has been pointed out that some intermolecular hydrogen bonds exist connecting the C(3)-OH...O(5') intramolecular hydrogen bonds. The above solubility results suggest that the interaction of NaSCN with cellulose solid is quite different from that of Ca(SCN)₂.

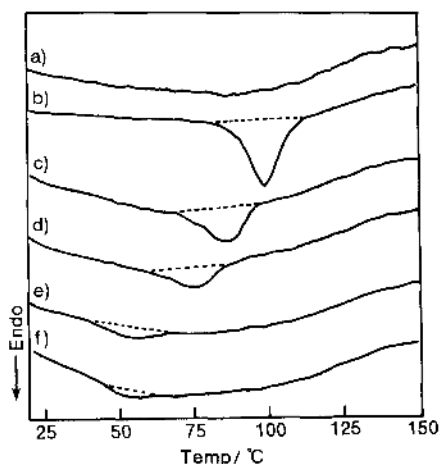

Figure 2. DSC curves of the samples CP (a), CAR-2 (b), and MC1-4 (c-f) in 60 wt% aq sodium thiocyanate soln. on heating.

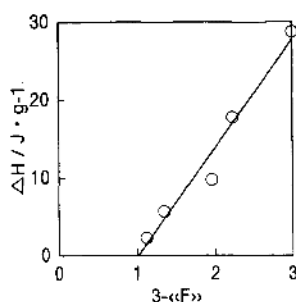

Figure 3. The relationship between endothermic heat ΔH of methyl cellulose and $(3-\langle F \rangle)$.

Interaction of Sodium Thiocyanate with Cellulose

Figure 2 shows DSC curves of the samples CP (a), CAR-2 (b), and MC1-4 (c-f) in 60 wt% aq NaSCN soln. on heating. The insoluble CP sample shows no peak during heating, but the soluble sample CAR-2, cellulose regenerated from cuprammonium soln., reveals an endothermic peak near dissolution temperature. In the previous paper¹² we reported that cellulose-55 wt% aq $\text{Ca}(\text{SCN})_2$ soln. exhibits an exothermic DSC peak attributable to cellulose-aq $\text{Ca}(\text{SCN})_2$ complex formation far below the dissolution temperature and shows no peak near the actual dissolving temperature. This quite different behavior of $\text{Ca}(\text{SCN})_2$ suggests that aq NaSCN molecules do not form complexes with cellulose molecules and the endothermic peak in the DSC thermogram of the regenerated cellulose arises from destruction of hydrogen bonds and fusion of crystalline part.

Samples MC1 and 2 with $\langle F \rangle = 0.77$ and 1.04 clearly dissolve in 60 wt% aq NaSCN soln. But the solubility of MC monotonically decreases with increase of $\langle F \rangle$. In Figure 3, endothermic heat ΔH of methyl cellulose is plotted against residual OH probability $(3-\langle F \rangle)$. The decrease in $\langle F \rangle$ brings about increase in ΔH , just corresponding to the solubility. This indicates that endothermic heat ΔH evolves from interactions of hydroxyl groups in cellulose with aq NaSCN. The limited methylation of cellulose may break the intra- and intermolecular hydrogen bonds at least partly, leading to an increase in the solubility. This seems evidence that NaSCN molecules interact with hydroxyl group and dissolve cellulose only when hydrogen bondings are

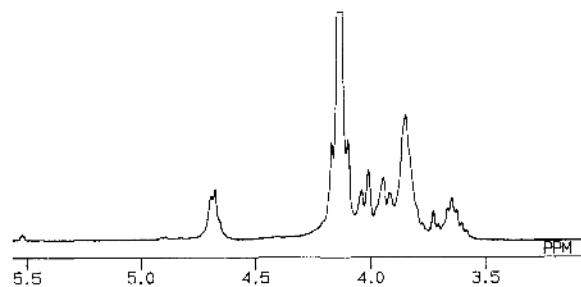

Figure 4. 1D ^1H NMR spectrum of hydrolyzed regenerated cellulose with $DP_v=30$ in $\text{Ca}(\text{SCN})_2\text{-D}_2\text{O}$ system at 100°C .

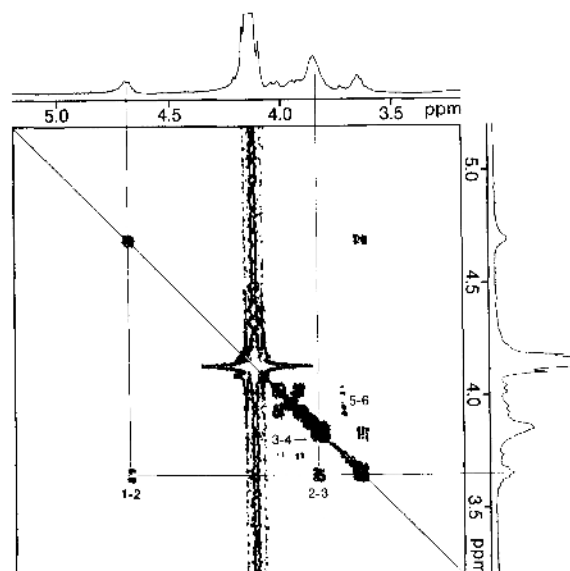

Figure 5. $^1\text{H}\text{-}^1\text{H}$ COSY spectrum of hydrolyzed regenerated cellulose with $DP_v=30$ in $\text{Ca}(\text{SCN})_2\text{-D}_2\text{O}$ system at 100°C .

partially broken down in the cellulose solid.

NMR Spectra of Cellulose/aq $\text{Ca}(\text{SCN})_2$ Solution System

1D ^1H NMR spectrum of hydrolyzed regenerated cellulose with $DP_v=30$ in $\text{Ca}(\text{SCN})_2\text{-D}_2\text{O}$ system is shown in Figure 4. $^1\text{H}\text{-}^1\text{H}$ COSY spectrum of the same system is depicted in Figure 5. Despite homogate decoupling, a very large peak due to residual proton in the solvent was observed at $\delta_H=4.13$ ppm. The peaks observed near 4.9 and 5.5 ppm in Figure 4 are attributable to hydroxyl groups in the pyranose ring. However, these peaks are too weak in intensity probably due to deuteration by solvent and rapid exchanging with residual H_2O , and could not be used effectively in analyzing the $^1\text{H}\text{-}^1\text{H}$ COSY spectrum. A broad peak centered at chemical shift $\delta_H=3.84$ ppm is relatively higher in intensity than those of the other peaks, suggesting that the broad peak includes some proton peaks. The peak near $\delta_H=4.7$ ppm is a doublet ($\delta_H=4.675$ and 4.695 ppm) and appears at the lowest magnetic field, except for the peaks of the hydroxyl protons, supporting that this peak is attributed to anomeric protons at C(1) carbon position (H(1)).¹⁹ 2 doublet peaks are seen in $\delta_H=3.9\text{--}4.1$ ppm and two complex peak groups are seen at $\delta_H=3.7$, and 3.6 ppm. In Figure 5, diagonal peaks correspond to each peak in the 1D spectrum and cross-peaks exhibit coupling between neighboring protons. Accordingly, a complex (triplet) proton peak

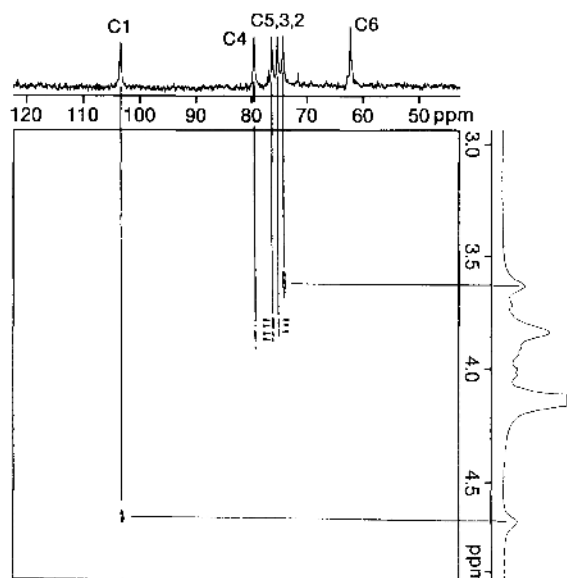

Figure 6. ^{13}C - ^1H COSY spectrum of hydrolyzed regenerated cellulose with $DP_n=30$ in $\text{Ca}(\text{SCN})_2\text{-D}_2\text{O}$ at 100°C . Horizontal and longitudinal axes are ^{13}C and ^1H chemical shifts and projections on the axes are ^{13}C and ^1H NMR spectra, respectively.

near $\delta_{\text{H}}=3.6$ ppm in 1D spectrum reveals vicinal coupling with the H(1) peak at $\delta_{\text{H}}=4.675\text{--}4.695$ ppm and is assigned to H(2). The triplet nature of the H(2) peak probably means that the coupling constants $J_{\text{H}(1)\text{--H}(2)}$ and $J_{\text{H}(2)\text{--H}(3)}$ are almost equal. The triplet H(2) peaks are also closely correlated with a broad peak at 3.805, 3.825, and 3.845 ppm (these positions are higher magnetic field region of the broad peak centered at 3.84 ppm), indicating that the overlapped broad peak contains H(3) protons in the higher magnetic range of 3.80--3.84 ppm. The cross peaks of H(3) H(4) and H(4) H(5) closely overlapped with each autocorrelation peak. But close inspection reveals that one of H(3) peaks at $\delta_{\text{H}}=3.805$ ppm has cross-peak at $\delta_{\text{H}}=3.865$ ppm, indicating this peak is assigned to a H(4) peak. The peaks at $\delta_{\text{H}}=3.916$ and 3.943 ppm closely correlate with the peaks at $\delta_{\text{H}}=4.011$ and 4.040 ppm each other, strongly suggesting that these peaks split into quartet peaks assigned to non-equivalent two H(6) protons. A not-yet assigned H(5) peak may thus overlap with H(3) or H(4) peak, but the complex peak at $\delta_{\text{H}}=3.7$ ppm is assigned to one of the H(5) sextet peaks correlated with H(6).

Figure 6 shows the ^{13}C - ^1H COSY spectrum. Horizontal and longitudinal axes are ^{13}C and ^1H chemical shifts, respectively and projections on each axis are also shown. Peaks on 2D-spectrum clearly show C-H scalar-coupling, indicating correlation between ^{13}C ^1H peaks. Based on the assignment on proton peaks, determined in Figures 4 and 5, two peaks at $\delta_{\text{C}}=103.339$ and 74.347 ppm in ^{13}C NMR spectrum are exactly assigned to the C(1) and C(2) carbon peaks. The carbon peak at $\delta_{\text{C}}=79.584$ ppm shows cross correlation with the broad peak $\delta_{\text{H}}=3.84$ ppm, in which multiple peaks of H(4) proton are included. According to computer analysis on the chemical shifts in ^{13}C NMR spectrum using cellobiose as a model of cellulose, C(4) carbon chemical shift appears at the lowest magnetic field next to C(1) carbon, irrespective of the chain conformation of the cellobiose.²⁰ From these facts, $\delta_{\text{C}}=79.584$ ppm is

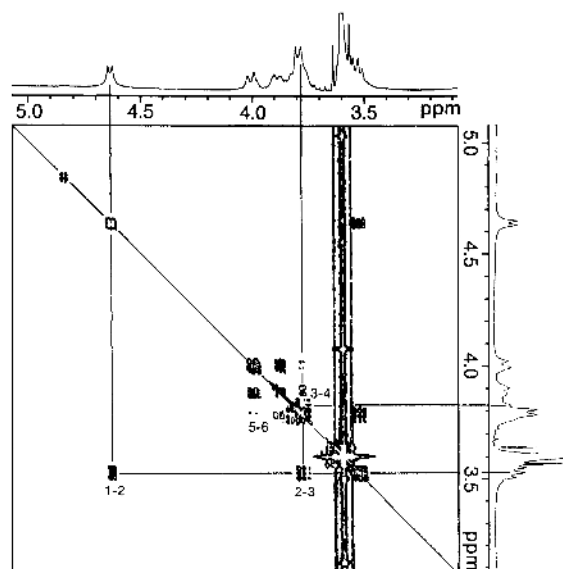

Figure 7. ^1H - ^{11}C COSY spectrum of hydrolyzed regenerated cellulose with $DP_n=30$ in $\text{NaSCN-D}_2\text{O}$ system at 100°C .

assigned to C(4) proton. The C(6) carbon peak is expected to be at highest magnetic field, because C(6) carbon is only one methylene carbon in the glucopyranose ring. All peaks except for that at $\delta_{\text{C}}=62.234$ ppm closely correlate with proton peaks other than the H(6) proton peak. The peak at $\delta_{\text{C}}=62.234$ ppm was thus assigned to C(6) carbon, while the correlation between the peak at $\delta_{\text{C}}=62.234$ ppm and the H(6) peak was not observed. The reason is not clear and probably due to the measuring conditions although the same measuring conditions give a clear correlation of cellulose/aq NaSCN. The peak at $\delta_{\text{C}}=75.334$ reveals coupling with triplet peaks at $\delta_{\text{H}}=3.805$, 3.825, and 3.845 ppm, leading to the conclusion that the peak at $\delta_{\text{C}}=75.334$ ppm arises from C(3) carbon. Finally, the remaining unassigned carbon peaks at $\delta_{\text{C}}=76.305$ ppm, coupled with quartet proton peaks near $\delta_{\text{H}}=3.84$ ppm, might be attributed to C(5) peaks.

NMR Spectra of Cellulose/aq NaSCN Solution System

2D ^1H - ^1H COSY spectra of cellulose with $DP_n=30$ in 60 wt% NaSCN/ D_2O soln. is shown in Figure 7. According to analysis of the 1D ^1H NMR spectrum of cellulose in aq $\text{Ca}(\text{SCN})_2\text{-D}_2\text{O}$ soln., the doublet peak near $\delta_{\text{H}}=4.6$ ppm ($\delta_{\text{H}}=4.626$ and 4.646 ppm), which appears at the lowest magnetic field, is assigned to anomeric proton at C(1) carbon position (H(1)). The triplet proton peak in the range of $\delta_{\text{H}}=3.55\text{--}3.50$ ppm in 1D spectrum, which reveals vicinal coupling with the H(1) peak, is attributed to H(2). The vicinal coupling triplet peak ($\delta_{\text{H}}=3.803$, 3.781, 3.756 ppm) with H(2) proton peak is judged to arise from H(3) proton. Similarly, another triplet peak at $\delta_{\text{H}}=3.849$, 3.829, and 3.803 ppm is assigned to H(4) proton. Here, the peaks at $\delta_{\text{H}}=3.803$ ppm of H(3) and H(4) proton overlap each other. The doublet peak at $\delta_{\text{H}}=4.108$ and 3.991 ppm closely correlates with the other doublet peak at $\delta_{\text{H}}=3.898$ and 3.879 ppm, strongly suggesting that these peaks split into quartet peaks assigned to non-equivalent two H(6) protons. The peak near $\delta_{\text{H}}=3.8$ ppm which shows vicinal coupling with quartet peaks of H(6) protons

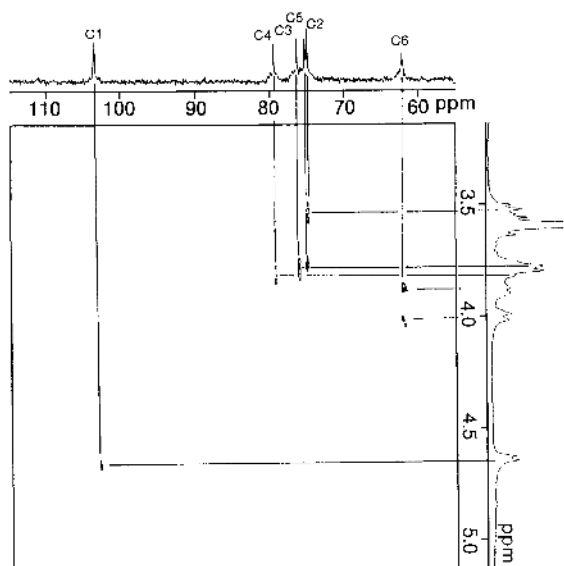

Figure 8. ^{13}C - ^1H COSY spectrum of hydrolyzed regenerated cellulose with $DP_n=30$ in $\text{NaSCN-D}_2\text{O}$ at 100°C . Horizontal and longitudinal axes are ^{13}C and ^1H chemical shifts and projections on the axes are ^{13}C and ^1H NMR spectra, respectively.

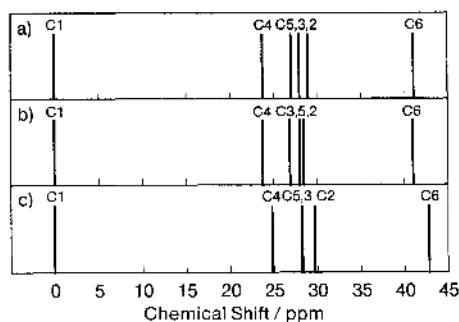

Figure 9. The chemical shifts of carbon peaks of cellulose from C(1) carbon position in 55 wt% $\text{Ca}(\text{SCN})_2\text{-D}_2\text{O}$ (a), 60 wt% $\text{NaSCN-D}_2\text{O}$ (b), and 10 wt% $\text{NaOH-D}_2\text{O}$ (c).

is considered to be related to a part of H(5). Considering the peaks of H(5) is expected to be sextet peak from cellulose chemical structure, the peaks which appear at $\delta_{\text{H}}=3.720, 3.698, 3.686$ ppm and shoulder of $\delta_{\text{H}}=3.876$ ppm seem to be assigned H(5) proton.

In Figure 8, a stacked plot of the ^{13}C - ^1H COSY spectrum is shown. On the basis of the assignment on proton peaks, determined in Figure 7, three peaks at $\delta_{\text{C}}=103.354, 74.878,$ and 62.340 ppm in ^{13}C NMR spectrum are exactly assigned to the C(1), C(2), and C(6) carbon peaks. The peak at $\delta_{\text{C}}=79.584$ ppm strongly correlates to the peak at $\delta_{\text{H}}=3.829$ ppm and slightly to that at $\delta_{\text{H}}=3.849$ and 3.803 ppm of H(4) proton, showing that the peak at $\delta_{\text{C}}=79.584$ ppm is attributed to C(4) carbon. Similarly, $\delta_{\text{C}}=76.457$ ppm corresponds to the triplet peak at $\delta_{\text{H}}=3.803, 3.781,$ and 3.756 ppm of H(3) proton, suggesting that the carbon peak is C(3). Finally, unassigned peak at $\delta_{\text{C}}=75.349$ ppm is concluded to be C(5) carbon.

Dissolved Cellulose in aq Thiocyanate Solution

In Figure 9, the chemical shifts of carbon peaks of cellulose in 55 wt% $\text{Ca}(\text{SCN})_2\text{-D}_2\text{O}$ solution (a), 60 wt% $\text{NaSCN-D}_2\text{O}$ solution (b), and 10 wt% $\text{NaOH-D}_2\text{O}$ solution⁸ (c) are represented. In the figure, the position

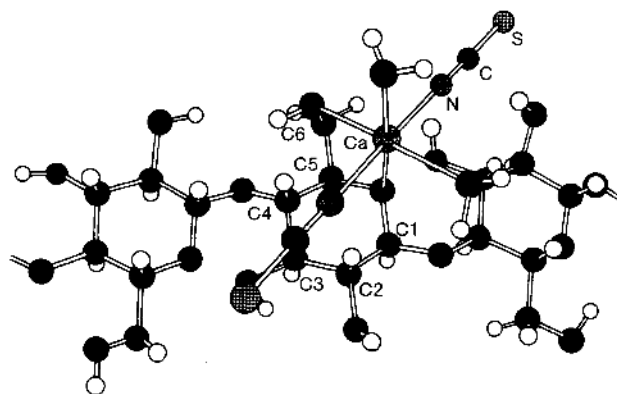

Figure 10. Interactions between cellulose and the calcium thiocyanate-water complex.

of chemical shift for C(1) carbon in every spectrum is chosen as the standard, because C(1) carbon is considered not interact directly with solvent molecules as is the case of other solvent systems.^{3,21-26} In ^{13}C NMR spectra of cellulose in both thiocyanate solutions, the six carbon peaks corresponding to the carbons constituting a glucopyranose ring appear in similar manner as the NMR spectra of cellulose in cadoxen,²² 10% NaOH ,⁸ *N*-methyl morpholine *N* oxide including water²⁷ and DMAc-LiCl .²³ In these solvents, the cellulose is dissolved without forming any cellulose derivatives. Therefore, both thiocyanate solutions seem not to derivatize the cellulose. The characteristic feature of $\text{Ca}(\text{SCN})_2$ and NaSCN is that all carbon peaks, except for C(3) carbon peak of cellulose in $\text{Ca}(\text{SCN})_2$ and C(5) peak in NaSCN , shift to lower magnetic fields, compared to the 10% aq NaOH soln. The relative position of C(3) and C(5) peaks in $\text{Ca}(\text{SCN})_2$ is different from that in NaSCN . Kamide *et al.*²⁵ proposed model on the dissolved state of cellulose in 8–10 wt% aq NaOH soln. That is, in the solvent system, one mole of dissociated sodium or hydroxyl ions is solvated with about four moles of water molecules and has loosely bonded water layer (2nd solvation area), but these Na and OH ions do not closely interact with specific position of cellulose molecule. Note that the prerequisite is that in this state C(3)-OH \cdots O(5') intramolecular hydrogen bonds are broken. As described before, in the aq $\text{Ca}(\text{SCN})_2$ soln., undissociated $\text{Ca}(\text{SCN})_2$ molecules form complexes with water molecules and in the mixture of cellulose-aq $\text{Ca}(\text{SCN})_2$ soln., calcium atoms of the complex coordinate with ring oxygen (O(5)) and hydroxyl oxygen at C(6) position (O(6)), as shown in Figure 10. It is plausible to consider that C(5) and C(6) carbon peak of cellulose in aq $\text{Ca}(\text{SCN})_2$ soln. might shift to lower magnetic fields, compared with cellulose in aq NaOH soln., C(3) carbon should be in non-intramolecular hydrogen bonded state as is the case of cellulose/aq NaOH system, suggesting the chemical shifts of C(3) in aq NaOH and aq $\text{Ca}(\text{NCS})_2$ are in a similar region, as proved in Figure 9. A possible interaction model between calcium thiocyanate hydrate and cellulose is shown in Figure 10, suggesting that C(2) carbon is located in the deshielding area from $\text{N}=\text{C}=\text{S}$ parts of $\text{Ca}(\text{NCS})_2 \cdot 2\text{H}_2\text{O}$, as cellulose solvents or π electron surrounding $-\text{N}=\text{C}=\text{S}$ might interact with hydroxyl proton on C(2) carbon, leading to lower magnetic field shifts of C(2) carbon, compared with that in aq NaOH .

In the spectrum of cellulose–60 wt%NaSCN/D₂O, C(2), C(3), and C(6) peaks shift to far lower magnetic field than that of 10% NaOH, respectively, while only the C(5) peak remains unmoved. This strongly suggests that Na atoms interact with three hydroxyl groups in the glucopyranose ring of the cellulose and do not coordinate with O(5) in the glucopyranose. This seems the reason why the concentrated aq NaSCN soln. is able only to dissolve cellulose solid in which at least half the intra- and intermolecular hydrogen bonds are perfectly broken.

The chemical shifts of C(4) carbon estimated by computer analysis on the cellobiose as a model of cellulose appear between C(1) and C(3) carbon chemical shifts due to chain conformation represented by torsional angle around the bridge oxygen.²⁰ From these results, cellulose molecules in the two thiocyanate solvents are considered to take quite different conformation from in the 10% NaOH system.

CONCLUSION

Almost all celluloses are soluble in 55 wt% aq Ca(SCN)₂ soln. above *ca.* 100°C, while 60 wt% aq NaSCN soln. dissolves very limited cellulose mainly regenerated from cellulose solution. The solubility of the cellulose in aq NaSCN soln. is independent of crystal form, crystallinity, and degree of polymerization of the cellulose samples and determined by the degree of breakdown of intramolecular hydrogen bond as is the case of 9% aq NaOH soln. at 4°C. Comparison of carbon chemical shifts of cellulose in aq calcium thiocyanate soln. with 10% aq NaOH soln. implies that calcium atoms coordinate with oxygen atoms in skeletal glucose ring and in primary alcohol at C(6) position, as has been pointed out by the authors.¹³ From the carbon chemical shifts of C(3), C(2), and C(6) carbons of cellulose in aq NaSCN–D₂O soln., sodium atom was considered to closely interact with all hydroxyl oxygen atoms of the glucopyranose ring of cellulose molecules in solution.

Acknowledgment. The authors would express thanks to Dr. K. Okajima, Director of our company, for valuable discussion.

REFERENCES

1. S. M. Hudson and J. A. Cuculo, *J. Macromol. Sci., Rev. Macromol. Chem.*, **C18**, 1(1980).
2. C. L. McCormick and D. K. Lichatowich, *J. Polym. Sci., Polym. Lett. Ed.*, **17**, 479 (1979).
3. C. L. McCormick, P. A. Callais, and B. H. Hutchinson, Jr., *Macromolecules*, **18**, 2394 (1985).
4. H. Chanzy and A. Peguy, *J. Polym. Sci., Polym. Phys. Ed.*, **18**, 1137 (1980).
5. J. A. Cuculo, C. B. Smith, U. Sangwatanaroj, E. O. Stejskal, and S. S. Sankar, *J. Polym. Sci., Polym. Chem.*, **32**, 229 (1994).
6. J. A. Cuculo, C. B. Smith, U. Sangwatanaroj, E. O. Stejskal, and S. S. Sankar, *J. Polym. Sci., Part A. Polym. Chem.*, **32**, 241 (1994).
7. K. Kamide and K. Okajima, US Patent 4,634,470 (1987).
8. K. Kamide, K. Okajima, T. Matsui, and K. Kowsaka, *Polym. J.*, **16**, 857 (1984).
9. K. Kamide, K. Okajima, and K. Kowsaka, *Polym. J.*, **24**, 71 (1992).
10. M. Saito and Y. Shimaya, Japanese Applied Patent, P06-291125 (1994).
11. Y. Shimaya and M. Saito, Japanese Applied Patent P06-291124 (1994).
12. M. Hattori, Y. Shimaya, and M. Saito, *Polym. J.*, **30**, 37 (1998).
13. M. Hattori, T. Koga, Y. Shimaya, and M. Saito, *Polym. J.*, **30**, 43 (1998).
14. K. Okajima, Y. Matsuda, and K. Kamide, *Polym. International*, **25**, 145 (1991).
15. K. Nakama, M. Wada, T. Okano, and J. Sugiyama, Preprints of '95 Cellulose R&D, 2nd Annual Meeting of the Cellulose Society of Japan, 1995, p 83.
16. P. Scherrer, *Göttinger Nachr.*, 98 (1918).
17. W. Brown and R. Wikström, *Eur. Polym. J.*, **1**, 1 (1966).
18. See for example, J. Sugiyama, *Cell. Commun.*, **1**, 6 (1994).
19. A. E. Derome, "Modern NMR Techniques for Chemistry Research," Pergamon Books Ltd., Oxford, Japanese translation right arranged with Pergamon Books Ltd. through Japan UNI Agency, Inc., Tokyo, 1991, Chapter 8, p 213.
20. I. Miyamoto, M. Saito, and K. Okajima, Preprints of '95 Cellulose R&D, 2nd Annual Meeting of Cellulose Society of Japan, 1995, p 19. The paper is accepted to *Sen'i Kikai Gakkai Shi*.
21. B. Lindberg and B. Swan, *Acta Chem. Scand.*, **17**, 913 (1963).
22. A. D. Bain, D. R. Eaton, R. A. Hux, and J. P. K. Tong, *Carbohydrate Res.*, **84**, 1 (1980).
23. A. El-Kafrawy, *J. Appl. Polym. Sci.*, **27**, 2435 (1982).
24. J. S. Germain and M. Vincendon, *Organic Magnetic Resonance*, **21**, 371 (1983).
25. E. R. Maia and S. Perez, *Nouveau J. Chimie*, **7**, 89 (1983).
26. K. Kamide, K. Yasuda, T. Matsui, K. Okajima, and T. Yamashiki, *Cellulose Chemistry and Technology*, **24**, 23 (1990).
27. I. Nehls, B. Lukanoff, B. Philipp, and A. Zschunke, *Acta Polymerica*, **34**, 105 (1983).