

Solutions for Comfort and Safety on Vibrations Resulting from the Action of the Wind on the Building in the Form of Portico with Four Floors

G. B. M. Carvalho, V. A. C. Vale, E. T. L. Cöuras Ford

Abstract—With the aim of increasing the levels of comfort and security structures, the study of dynamic loads on buildings has been one of the focuses in the area of control engineering, civil engineering and architecture. Thus, this work presents a study based on simulation of the dynamics of buildings in the form of portico subjected to wind action, besides presenting an action of passive control, using for this the dynamics of the structure, consequently representing a system appropriated on environmental issues. These control systems are named the dynamic vibration absorbers.

Keywords—Dynamic vibration absorber, structure, comfort, safety, wind behavior, structure.

I. INTRODUCTION

THE structures may suffer from excessive vibration during the action of dynamic loads, developing large response amplitudes, causing discomfort to the users and can cause structural damage. Added to this, the buildings are increasingly tall and slender challenging structural designers to develop ever more efficient projects in the aspect of comfort and safety with arrangements that can use the shape and characteristics of building materials in their favor [1].

The levels of vibration can be controlled in three ways: reducing the intensity of the exciter source, isolating the excited structure, or modifying the dynamic characteristics of the structure [2]. Among them, the modification of the dynamic characteristics is the most viable for a large-scale structure because the excitatory sources are uncontrollable (winds and earthquakes, for example) and the isolation of a large structure is impractical due to high costs and the requisition large physical spaces.

In the USA, Japan, Russia, and several European countries, relevant studies have been developed for this area, and many control systems on the dynamic characteristics of the structures are being used to ensure the environmental comfort

G. B. M. Carvalho is architect and urban planner by Universidade Federal da Paraíba – UFPB, Cidade Universitária, S/N - Castelo Branco III, 58051-900, João Pessoa – PB, Brazil (e-mail: guilhardobarros@gmail.com).

V. A. C. Vale is Ph.D Student in Electrical Engineering; M.Sc. in Mechanical Engineering; Engineer of Safety; Electrical Engineer. Universidade Federal do Pernambuco – UFPE / PPGEE, Av. Prof. Moraes Rego, 1235 - Cidade Universitária, 50670-901, Recife – PE, Brazil (e-mail: alessandravale.doc@gmail.com).

E. T. L. Cöuras Ford is Ph.D in Mechanical Engineering; M.Sc. in Administration; M.Sc. in Mechanical Engineering; Engineer of Safety; Mechanical Engineer; Automotive Engineer. Universidade Federal do Rio Grande do Norte – UFRN / PPGCEM, Av. Senador Salgado Filho, S/N, 59072-970, Natal - RN, Brazil (e-mail: elmocouras@hotmail.com).

and safety of users [3]. These control systems are called dynamic vibration absorbers because they are responsible for eliminating or reducing the vibration. They may use external power sources and they are called active controllers, or may use the dynamics of the building as an energy source and are called passive controllers.

As energy issues are seen as a decisive factor by environmental aspect and cost, this paper focuses on a dynamic vibration absorber without the use of external power. An example of this control system extensively studied and used in large civil structures is Tuned Mass Damper (TMD), which consists of a secondary block with about 1% of the mass of the structure positioned generally on top of a building, coupled by a spring and a damper.

The first structure in which a TMD was installed concerns the Centrepoint Tower in Sydney, Australia, existing also in the USA two buildings with TMD, Citicorp Center in New York and the John Hancock Tower in Boston. In Japan, the first TMD was installed in Chiba Port Tower, according to [4]. Other control systems are studied by structure [5]-[7]. Note that these control systems can be applied to any structure, as in bridges and wind turbines with the growth of clean energy use. In [8], a passive system that uses TDM for vibrations from passing cars was presented. In [9], a passive system that uses alloy with shape memory to control vibrations in wind turbines was described.

This study is related to the effect of wind force overtime on a structure in the form of portico with four decks with and without dynamic vibration absorber, as well as the analysis of the response as the mass of the absorber.

II. METHODOLOGY

One of the advantages of the TMD system is that its installation does not require major modifications of structure [10], either a separate structure can be allocated at the top of the building or the own water supply can be used. Therefore, a control system of the type TMD for buildings of four stories in the form of portico will be proposed, so that its movement is opposed to the movement of the structure, serving properly to minimize wind action. The study is based on simulations in computational environment. The modeling for the system and for the load will be described below.

A. Wind Modeling

To simplify the analysis and to allow comparisons with different scenarios, the behavior of the wind will be

represented by sinusoidal functions positively displaced with different amplitudes as shown in Fig. 1 since, in a season, the wind tends to blow in one direction and with intensity varied. Note that the highest floor receives a higher intensity of wind due to the wind condition of the fluid itself in addition to empty spaces between the buildings.

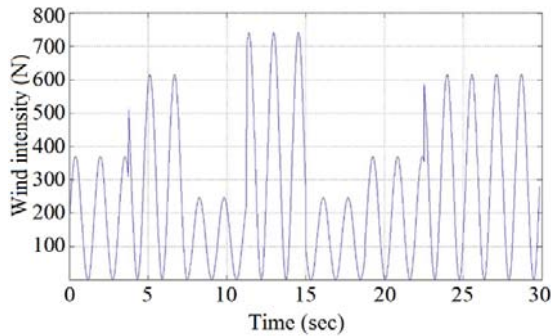

Fig. 1 Sketch of the signal that will represent the behavior of the wind on the top floor, the values being assigned to wind force were random

B. Modeling System for State Space

Each floor of a building can be represented by its mass (m_n), damping constant (b_n) and stiffness constant (k_n), where n refers to the number for pavement like in the scheme shown in Fig. 2.

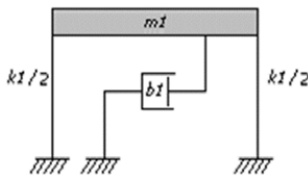

Fig. 2 Schematic of a floor of a building

Thus, (1) gives an equation associated with the axial movement of the pavement, where F is an acting force.

$$m_1 \cdot \ddot{x} + b_1 \cdot \dot{x} + k_1 \cdot x = F \quad (1)$$

Analogously, it is possible to obtain a scheme for a four-story building, see Fig. 3.

The equation describing axial motion for this four-floor structure can be written as follows, where \mathbf{M} , \mathbf{B} , and \mathbf{K}_G are mass, damping, and overall stiffness matrices respectively in (2).

$$\mathbf{M} \cdot \ddot{\mathbf{x}} + \mathbf{B} \cdot \dot{\mathbf{x}} + \mathbf{K}_G \cdot \mathbf{x} = \mathbf{F} \quad (2)$$

According to [11], the damping constants depend on the masses and the stiffness constants of each floor, while the stiffness constants depend on the material and the dimensions of the beams, as described in (3).

$$b_{n+1} = 2 \cdot k_{n+1} \cdot \xi_n \cdot \sqrt{\frac{m_n}{k_n + k_{n+1}}} \quad (3)$$

$$\begin{cases} \xi_{n+1} = \xi_n \cdot \sqrt{\left(\frac{m_n}{m_{n+1}}\right) \cdot \left(\frac{k_{n+1} + k_{n+2}}{k_n + k_{n+1}}\right)} \\ k_n = \epsilon_o \cdot \frac{A_n}{L_n} \end{cases} \begin{cases} \xi_n - \text{damping ratio} \\ \epsilon_o - \text{modulus of elasticity} \\ A_n - \text{column section area} \\ L_n - \text{column length} \end{cases}$$

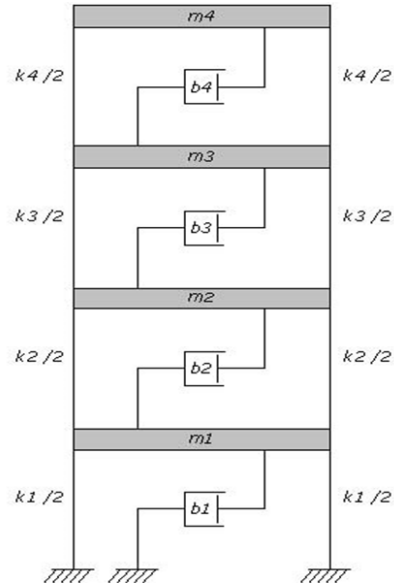

Fig. 3 Scheme of a four-floor building

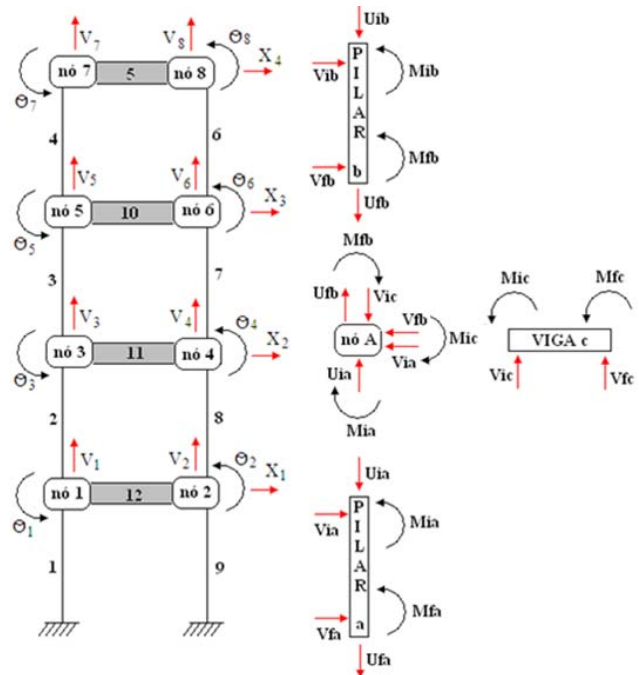

Fig. 4 Forces and moments acting on the nodes and the beams

The mass matrix is defined in the diagonal form, as we see in (4), where the non-zero term of the line corresponds to the mass of the respective floor.

$$\mathbf{M} = \begin{bmatrix} m_1 & 0 & 0 & 0 \\ 0 & m_2 & 0 & 0 \\ 0 & 0 & m_3 & 0 \\ 0 & 0 & 0 & m_4 \end{bmatrix} \quad (4)$$

The damping matrix has the form given in (5), since the damping of a top deck influences the lower deck.

$$\mathbf{B} = \begin{bmatrix} b_1 + b_2 & -b_2 & 0 & 0 \\ -b_2 & b_2 + b_3 & -b_3 & 0 \\ 0 & -b_3 & b_3 + b_4 & -b_4 \\ 0 & 0 & -b_4 & b_4 \end{bmatrix} \quad (5)$$

The \mathbf{K}_G matrix is obtained through the equilibrium conditions at the nodes and beams of the gantry structure, according to [12], where the forces and moments are schematized in Fig. 4 and defined in (6).

$$\begin{bmatrix} U_i \\ V_i \\ M_i \\ U_f \\ V_f \\ M_f \end{bmatrix} = \begin{bmatrix} \frac{\epsilon_o A}{L} & 0 & 0 & \frac{-\epsilon_o A}{L} & 0 & 0 \\ 0 & \frac{12 \epsilon_o I}{L^3} & \frac{6 \epsilon_o I}{L^2} & 0 & \frac{-12 \epsilon_o I}{L^3} & \frac{6 \epsilon_o I}{L^2} \\ 0 & \frac{6 \epsilon_o I}{L^2} & \frac{4 \epsilon_o I}{L} & 0 & \frac{-6 \epsilon_o I}{L^2} & \frac{2 \epsilon_o I}{L} \\ \frac{-\epsilon_o A}{L} & 0 & 0 & \frac{\epsilon_o A}{L} & 0 & 0 \\ 0 & \frac{-12 \epsilon_o I}{L^3} & \frac{-6 \epsilon_o I}{L^2} & 0 & \frac{12 \epsilon_o I}{L^3} & \frac{-6 \epsilon_o I}{L^2} \\ 0 & \frac{6 \epsilon_o I}{L^2} & \frac{2 \epsilon_o I}{L} & 0 & \frac{-6 \epsilon_o I}{L^2} & \frac{4 \epsilon_o I}{L} \end{bmatrix} \cdot \begin{bmatrix} x_i \\ v_i \\ \theta_i \\ x_f \\ v_f \\ \theta_f \end{bmatrix} + \begin{bmatrix} U_i^F \\ V_i^F \\ M_i^F \\ U_f^F \\ V_f^F \\ M_f^F \end{bmatrix} \quad (6)$$

$$I = \frac{1}{12} \cdot b \cdot h^3 \quad (7)$$

where i: initial, f: final, U: lateral forces, V: vertical forces, M: moments, I: moment of inertia of area, b: parallel to the axis passing in the center of the area considered, h: side that together with b forms the considered area.

The sum of the moments and vertical forces in each node and the horizontal forces in each beam form a set of equations, which arranged in the matrix will result in a $5n \times 5n$. The equilibrium moment conditions of each node are given in the $2n$ first lines, the equilibrium conditions of the vertical forces of each node are given in the $2n$ following lines, and the equilibrium conditions of the horizontal forces in the beams are given in the last n lines. The columns refer to the angular movement in the first $2n$ columns, the vertical movement in the next $2n$ columns, and the horizontal movement in the last columns, since the nodes in the same floor have the same displacement. This turns to the first floor in (8), where M, U and V are obtained through (6).

$$\begin{cases} \text{Sum of moments: } M_i^1 + M_f^2 + M_i^{12} \\ \text{Sum of vertical forces: } U_i^1 + U_f^2 - V_i^{12} \\ \text{Sum of horizontal forces: } V_i^1 + V_f^2 + V_i^9 + V_f^8 \end{cases} \quad (8)$$

In certain types of structural analysis, there is no interest in considering all possible degrees of freedom of the structure. This can be perceived, for example, in dynamic analysis of buildings, when it intends to study only lateral vibrations, as it is the case considered in this work. Therefore, the global stiffness matrix ($5n \times 5n$) can be condensed into a matrix ($n \times n$). According to [13], the global matrix can be divided into four sections (dependent on angles and vertical and horizontal movements), as we see in (9), using the manipulations, the condensed global stiffness matrix (18) is obtained.

$$\mathbf{K}_G = \begin{bmatrix} \mathbf{K}_{\delta\delta}^{4n \times 4n} & \mathbf{K}_{\delta x}^{4n \times n} \\ \mathbf{K}_{x\delta}^{n \times 4n} & \mathbf{K}_{xx}^{n \times n} \end{bmatrix} \quad (9)$$

$$\mathbf{K}_{xx} = \begin{bmatrix} k_1 + k_2 & -k_2 & 0 & 0 \\ -k_2 & k_2 + k_3 & -k_3 & 0 \\ 0 & -k_3 & k_3 + k_4 & -k_4 \\ 0 & 0 & -k_4 & k_4 \end{bmatrix} \quad (10)$$

$$\begin{bmatrix} 0 & 0 \\ 0 & M_{xx} \end{bmatrix} \cdot \begin{bmatrix} \ddot{\delta} \\ \ddot{x} \end{bmatrix} + \begin{bmatrix} 0 & 0 \\ 0 & B_{xx} \end{bmatrix} \cdot \begin{bmatrix} \dot{\delta} \\ \dot{x} \end{bmatrix} + \begin{bmatrix} K_{\delta\delta} & K_{\delta x} \\ K_{x\delta} & K_{xx} \end{bmatrix} \cdot \begin{bmatrix} \delta \\ x \end{bmatrix} = \begin{bmatrix} 0 \\ F \end{bmatrix} \quad (11)$$

$$\delta = \begin{bmatrix} \theta \\ v \end{bmatrix} \quad (12)$$

where: θ - angular displacement
 v - vertical displacement
 x - lateral displacement
 \mathbf{K}_G - global stiffness matrix

Manipulating (11):

$$\mathbf{K}_{\delta\delta} \cdot \delta + \mathbf{K}_{\delta x} \cdot x = 0 \quad (13)$$

$$\mathbf{M} \cdot \ddot{x} + \mathbf{B}_{xx} \cdot \dot{x} + \mathbf{K}_{x\delta} \cdot \delta + \mathbf{K}_{xx} \cdot x = F \quad (14)$$

Resulting:

$$\delta = -\mathbf{K}_{\delta\delta}^{-1} \cdot \mathbf{K}_{\delta x} \cdot x \quad (15)$$

$$\mathbf{M}_{xx} \cdot \ddot{x} + \mathbf{B}_{xx} \cdot \dot{x} + \mathbf{K}_C \cdot x = F \quad (16)$$

$$\mathbf{K}_C = \mathbf{K}_{xx} - \mathbf{K}_{x\delta} \cdot \mathbf{K}_{\delta\delta}^{-1} \cdot \mathbf{K}_{\delta x} \quad (17)$$

$$\mathbf{K}_C = \begin{bmatrix} K_C^{1,1} & K_C^{1,2} & K_C^{1,3} & K_C^{1,4} \\ K_C^{2,1} & K_C^{2,2} & K_C^{2,3} & K_C^{2,4} \\ K_C^{3,1} & K_C^{3,2} & K_C^{3,3} & K_C^{3,4} \\ K_C^{4,1} & K_C^{4,2} & K_C^{4,3} & K_C^{4,4} \end{bmatrix} \quad (18)$$

$$\text{Doing : } \begin{cases} x_1 = x \\ x_2 = x_1 = x \end{cases} \rightarrow \begin{cases} \dot{x}_1 = \dot{x} = \dot{x}_2 \\ \ddot{x}_1 = \ddot{x} = \ddot{x}_2 \end{cases}$$

Substituting into the differential equation governing the system (ii), it is obtained (19), where I_M is an identity matrix.

$$\begin{bmatrix} \dot{x}_1 \\ \dot{x}_2 \end{bmatrix} = \begin{bmatrix} 0 & I_M \\ -M^{-1} \cdot K_C & -M^{-1} \cdot B \end{bmatrix} \begin{bmatrix} x_1 \\ x_2 \end{bmatrix} + \begin{bmatrix} 0 \\ M^{-1} \end{bmatrix} \cdot F \quad (19)$$

$$y = [I_M \quad 0] \cdot \begin{bmatrix} x_1 \\ x_2 \end{bmatrix}$$

C. System Modeling Added to a Dynamic Vibration Absorber

By coupling the dynamic vibration absorber to the fourth floor, Fig. 5, it will behave as a fifth floor with mass, damping constant, and spring constant (equivalent to rigidity) equal to m_t , b_t , and k_t , respectively.

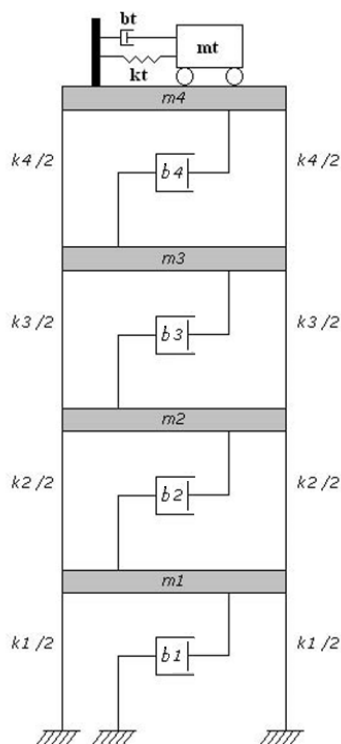

Fig. 5 Coupling of dynamic absorber to four-story building

Obtaining the same state space equation with the matrices M , B , K_{xx} and K_C , given below:

$$M = \begin{bmatrix} m_1 & 0 & 0 & 0 & 0 \\ 0 & m_2 & 0 & 0 & 0 \\ 0 & 0 & m_3 & 0 & 0 \\ 0 & 0 & 0 & m_4 & 0 \\ 0 & 0 & 0 & 0 & m_t \end{bmatrix} \quad (20)$$

$$B = \begin{bmatrix} b_1 + b_2 & -b_2 & 0 & 0 & 0 \\ -b_2 & b_2 + b_3 & -b_3 & 0 & 0 \\ 0 & -b_3 & b_3 + b_4 & -b_4 & 0 \\ 0 & 0 & -b_4 & b_4 + b_t & -b_t \\ 0 & 0 & 0 & -b_t & b_t \end{bmatrix} \quad (21)$$

$$K_{xx} = \begin{bmatrix} k_1 + k_2 & -k_2 & 0 & 0 & 0 \\ -k_2 & k_2 + k_3 & -k_3 & 0 & 0 \\ 0 & -k_3 & k_3 + k_4 & -k_4 & 0 \\ 0 & 0 & -k_4 & k_4 + k_t & -k_t \\ 0 & 0 & 0 & -k_t & k_t \end{bmatrix} \quad (22)$$

$$K_C = \begin{bmatrix} K_C^{1,1} & K_C^{1,2} & K_C^{1,3} & K_C^{1,4} & 0 \\ K_C^{2,1} & K_C^{2,2} & K_C^{2,3} & K_C^{2,4} & 0 \\ K_C^{3,1} & K_C^{3,2} & K_C^{3,3} & K_C^{3,4} & 0 \\ K_C^{4,1} & K_C^{4,2} & K_C^{4,3} & K_C^{4,4} + \xi \cdot k_t & -\xi \cdot k_t \\ 0 & 0 & 0 & -\xi \cdot k_t & \xi \cdot k_t \end{bmatrix} \quad (23)$$

D. Responses to a Four-Story Building

The data used in this work for the simulation can be verified in Table I.

TABLE I
DATA FOR SIMULATION

Symbol	Variable	Value
m_1	First floor mass	22287.5 kg
m_2	Second floor mass	22287.5 kg
m_3	Third floor mass	21837.5 kg
m_4	Fourth floor mass	21837.5 kg
$(i \times j \times k)$	Dimensions of beams	$(5 \times 0.5 \times 0.15) \text{ m}^3$
$(i \times j \times k)$	Pillars' dimensions of first and second floor	$(0.6 \times 3 \times 0.15) \text{ m}^3$
$(i \times j \times k)$	Pillars' dimensions of third and fourth floor	$(0.4 \times 3 \times 0.15) \text{ m}^3$
ϵ	Modulus of elasticity	$2.9 \times 10^{10} \text{ N/m}^2$
ξ	Damping ratio	2%
m_t	Mass of the absorber	-
b_t	Absorber damping constant	$0.624238 \times 10^3 \text{ N.seg/m}$
k_t	Constant spring absorber	$1538.41 \times 10^3 \text{ N/m}$

From a routine in MATLAB, the matrices of mass, damping, and stiffness were found. For the mass matrix, the respective values presented in Table I were arranged in (4) and (20), with m_t initially not assigned. For the damping matrix, the b_t of Table I was arranged in (5) and (21). For the condensed global stiffness matrix, the overall stiffness matrix was found, through the equilibrium conditions which were compared with (9) to be used in (17). The matrices were set out in Table II.

The following results are considering a dynamic absorber of mass equal to 220.62 kg, 441.25 kg, 882.5 kg, and 1765 kg

Using the state space modeling equation (19) and the matrices that characterize the system, we simulated the responses to the wind action in Fig. 1 without absorber, this was weighted so that the first floor received 25% of the wind intensity and the last floor received 100% of the intensity.

TABLE II
 MATRICES OBTAINED

Matrix	Without absorber	With absorber
Mass (M)	$\begin{bmatrix} 22287.5 & 0 & 0 & 0 \\ 0 & 22287.5 & 0 & 0 \\ 0 & 0 & 21837.5 & 0 \\ 0 & 0 & 0 & 21837.5 \end{bmatrix}$	$\begin{bmatrix} 22287.5 & 0 & 0 & 0 & 0 \\ 0 & 22287.5 & 0 & 0 & 0 \\ 0 & 0 & 21837.5 & 0 & 0 \\ 0 & 0 & 0 & 21837.5 & 0 \\ 0 & 0 & 0 & 0 & m_t \end{bmatrix}$
Damping (B)	$10^4 \begin{bmatrix} 7.0455 & -3.5227 & 0 & 0 \\ -3.5227 & 4.5665 & -1.0438 & 0 \\ 0 & -1.0438 & 2.0875 & -1.0438 \\ 0 & 0 & -1.0438 & 1.0438 \end{bmatrix}$	$10^4 \begin{bmatrix} 7.0455 & -3.5227 & 0 & 0 & 0 \\ -3.5227 & 4.5665 & -1.0438 & 0 & 0 \\ 0 & -1.0438 & 2.0875 & -1.0438 & 0 \\ 0 & 0 & -1.0438 & 1.1062 & -0.0624 \\ 0 & 0 & 0 & -0.0624 & 0.0624 \end{bmatrix}$
Condensed global stiffness (K_c)	$10^8 \begin{bmatrix} 1.0834 & -0.5276 & 0.0885 & -0.0090 \\ -0.5276 & 0.5607 & -0.2471 & 0.0399 \\ 0.0885 & -0.2471 & 0.3281 & -0.1518 \\ -0.0090 & 0.0399 & -0.1518 & 0.1188 \end{bmatrix}$	$10^8 \begin{bmatrix} 1.0834 & -0.5276 & 0.0885 & -0.0090 & 0 \\ -0.5276 & 0.5607 & -0.2471 & 0.0399 & 0 \\ 0.0885 & -0.2471 & 0.3281 & -0.1518 & 0 \\ -0.0090 & 0.0399 & -0.1518 & 0.1188 & -0.0003 \\ 0 & 0 & 0 & -0.0003 & 0.0003 \end{bmatrix}$

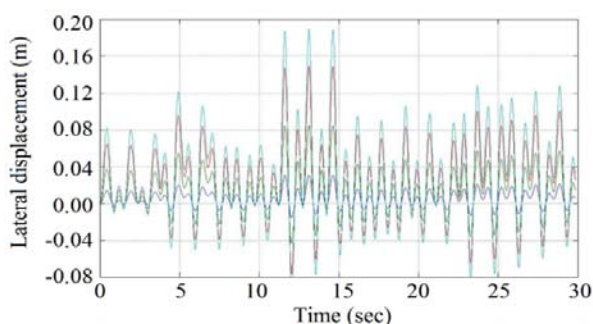

Fig. 6 Response to the wind all building floors without absorber

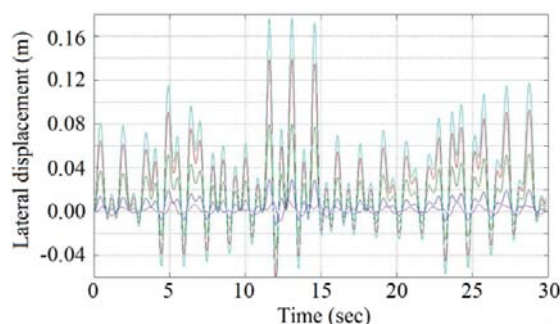

Fig. 9 Response to the wind all building floors with $m_t = 882.5$ kg

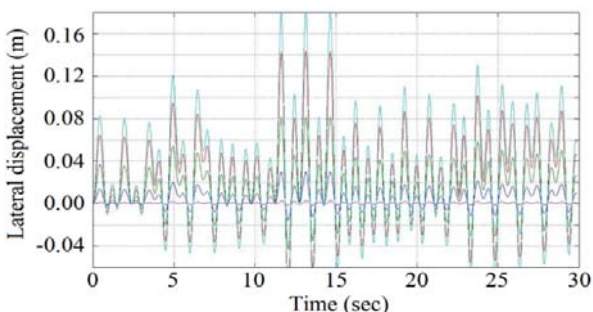

Fig. 7 Response to the wind all building floors with $m_t = 220.62$ kg

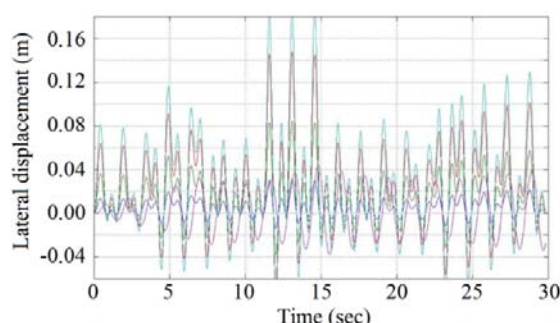

Fig. 10 Response to the wind all building floors with $m_t = 1765$ kg

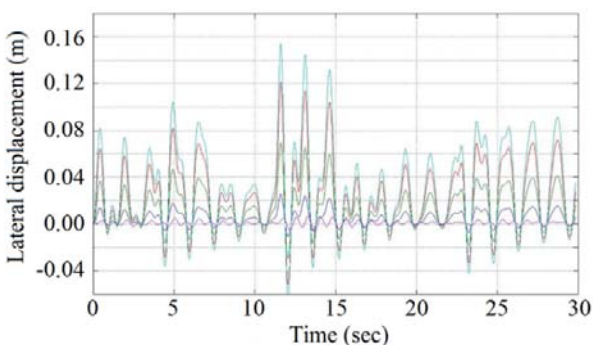

Fig. 8 Response to the wind all building floors with $m_t = 441.25$ kg

III. FINAL CONSIDERATIONS

The suggested value of 1% of the mass of the TMD type absorber did not present the best solution for this particular case. For this, simulations were performed for absorbers with a mass equivalent to 0.25%, 0.5%, 1%, and 2% of the mass of the structure. We conclude that, for values lower than 0.5% and above 1%, the behavior of the structure was similar to the absence of absorber.

Considering the results obtained in the figures referring to the building responses, with and without absorber, it can be said that the best dynamic absorber for this particular case is that which has a mass corresponding to 0.5% of the mass of the structure ($m_t = 441.25$ kg). In the analysis of the building without the absorber, the amplitude of the oscillation in favor

of the wind is approximately 15% higher than with the best absorber, comparing their respective peak moments.

The building had a greater lateral displacement in the upper floors, as expected, since it behaves like an inverted pendulum. Although the building moves further to the downwind side, in both cases, of the building with and without absorber, it continues to suffer a displacement in the opposite direction, due to the inertia of the building. However, the absorber also decreases and limits the oscillation in the reverse direction.

ACKNOWLEDGMENT

Thanks go to CAPES, UFPB, UFPE, and UFRN for providing the means to carry out this work.

REFERENCES

- [1] F. D. S. Oliveira, "Otimização Topológica de Dissipadores Metálicos Aplicados ao Controle de Vibrações em Estruturas," 2016.
- [2] Y. Du, "Internal Resonances in Vibration Isolators and their Control Using Passive and Hybrid Dynamic Vibration Absorbers," April 2003.
- [3] S. Antunes e J. Patrício, "Metodologias para Avaliação da Incomodidade Induzida por Vibrações," 2º Encontro Nacional sobre Qualidade e Inovação na Construção, 2016.
- [4] G. W. Housner, L. A. Bergman, T. K. Caughey, A. G. Chassiakos, R. O. Claus, S. F. Masri e J. T. Yao, "Structural Control: Past, Present and Future," Journal of Engineering Mechanics, 1997.
- [5] A. Castellani, G. Kajon, P. Panzeri e P. Pezzoli, "Elastomeric Materials Used for Vibration Isolation of Railway Lines," Journal of Engineering Mechanics, 1998.
- [6] K. Kawazoe, I. Kono, T. Aida, T. Aso e K. Ebisuda, "Beam-Type Dynamic Vibration Absorber Comprised of Free-Free Beam," Journal of Engineering Mechanics, 1998.
- [7] A. F. R. D. Lima, "Controle Passivo de Vibrações de Sistemas Não-Lineares Empregando Ligas com Memória de Forma," Universidade Federal de Uberlândia, 2015.
- [8] G. W. Silva, L. B. Oliveira e F. R. Silva, "Modelagem, Simulação e Projeto de Absorvedores Passivos de Vibrações em Pontes," Rio de Janeiro, 2015.
- [9] W. M. Pereira, "Influência do Controle Estrutural na Otimização de Torres de Sustentação de Aerogeradores," Universidade de Brasília, 2016.
- [10] M. Abé, "Rule-Based Control Algorithm for Active Mass Dampers," Journal of Engineering Mechanics, 1996.
- [11] M. M. L. Accioly, "Controle de Vibrações em Edifícios Submetidos à Ação de Cargas Dinâmicas," Universidade Federal da Paraíba, 2000.
- [12] J. M. Gere e W. W. Jr., "Análise de Estruturas Reticuladas," Rio de Janeiro: Editora Guanabara S. A., 1987.
- [13] R. W. Clough e J. Penzien, "Dynamics of Structures," 2nd ed. Singapore: McGraw-Hill International Editions, 1993.