

Sovereign Default, Domestic Banks, and Financial Institutions

NICOLA GENNAIOLI, ALBERTO MARTIN, and STEFANO ROSSI*

ABSTRACT

We present a model of sovereign debt in which, contrary to conventional wisdom, government defaults are costly because they destroy the balance sheets of domestic banks. In our model, better financial institutions allow banks to be more leveraged, thereby making them more vulnerable to sovereign defaults. Our predictions: government defaults should lead to declines in private credit, and these declines should be larger in countries where financial institutions are more developed and banks hold more government bonds. In these same countries, government defaults should be less likely. Using a large panel of countries, we find evidence consistent with these predictions.

JEL classification: F34, F36, G15, H63.

*Bocconi University and CREI, E-mail: nicola.gennaioli@unibocconi.it; CREI, UPF and Barcelona GSE, E-mail: amartin@crei.cat; and Purdue University, CEPR, and ECGI, E-mail: stefanorossi@purdue.edu. We are grateful for helpful suggestions from seminar participants at the American Finance Association meetings, the NBER meetings in International Finance and Macroeconomics, the "Sovereign Debt Risk" conference at the George Weiss Center for International Financial Research at Wharton, Bank of England, Bank of Spain, CERGE-EI, CEU, Helsinki, IAE, Lausanne, New York University Stern School of Business, Samuel Johnson Graduate School of Management at Cornell University, Purdue, PSE, Stockholm School of Economics, University of Vigo, ESSIM, XI Workshop in International Economics and Finance in Montevideo, and at the Workshop in Institutions, Contracts and Growth in Barcelona. We have received helpful comments from Senay Agca, Mark Aguiar, Philippe Bacchetta, Matt Billett, Fernando Broner, Eduardo Fernandez-Arias, Pierre-Olivier Gourinchas, Bernardo Guimaraes, Andrew Karolyi, Philip Lane, Andrei Levchenko, Kose John, Guido Lorenzoni, Romain Rancière, Hélène Rey, David Robinson, Katrin Timm and Jaume Ventura. We also thank Campbell Harvey, the editor, an anonymous referee, and an anonymous associate editor. Gonçalo Pina and Robert Zymek provided excellent research assistantship. Gennaioli thanks the European Research Council for financial support and the Barcelona GSE Research Network. Martin acknowledges support from the Spanish Ministry of Science and Innovation (grant Ramon y Cajal RYC-2009-04624), the Spanish Ministry of Economy and Competitiveness (grant ECO2011-23192), the Generalitat de Catalunya-AGAUR (grant 2009SGR1157) and the Barcelona GSE Research Network.

Why do governments repay their debts? Conventional wisdom holds that they do so to avoid foreign sanctions or exclusion from international financial (or goods) markets (see Eaton and Fernández (1995) for a survey). In reality, sanctions are rarely observed and market exclusion is short lived. Therefore, to rationalize the relatively low frequency of defaults, recent work argues that defaults must also impose a large cost on the domestic economy and that governments repay at least in part to avoid this cost (Arellano (2008)). But where does such a cost come from? A look at recent defaults suggests that it may originate in the banking sector. The Russian default of 1998, for instance, caused large losses to Russian banks because those banks were heavily invested in public bonds. In turn, banks' losses (together with the devaluation of the Ruble) precipitated a financial sector meltdown. During the same period, public defaults resulted in heavy losses to the banking systems of Ecuador, Pakistan, Ukraine and Argentina, leading to significant declines in credit (IMF (2002)).

The current debt crisis in Europe also illustrates the link between public default and financial turmoil. Starting in 2009, reports of bad news regarding the sustainability of public debt in Greece, Italy, and Portugal undermined the banking sectors in these countries precisely because the banks were exposed to their governments' bonds. Such reports have also negatively affected other European banks such as Dexia in Belgium, Société Générale and Crédit Agricole in France, and several Landesbanken in Germany, which were all heavily exposed to the debts of the financially distressed countries. These events played a key role in the decision to refinance the European Financial Stability Fund: averting sovereign defaults was seen as a key prerequisite to avoid widespread banking crises.¹

Existing models of sovereign debt fail to account for these events because they assume that governments can shield the domestic financial system from the consequences of a default, either through (i) selective defaults only on foreign bondholders, or (ii) selective bailouts that protect domestic banks following a default. If such perfect "discrimination" is possible, then banks should not suffer direct losses from public defaults. In reality, however, it is hard for governments to exercise perfect discrimination. Selective default requires governments to perfectly target the bondholdings of foreigners, which can be hard in practice because these bonds are actively traded in secondary markets (see Broner et al. (2010)). In addition, while we routinely observe bailouts of individual banks, it is arguably difficult for a government in default to bail out its entire banking sector,

not least because of the government's difficulties in accessing financing at such times. As a result, imperfect discrimination provides a promising perspective to rationalize the large and potentially costly domestic redistributions of wealth observed in real-world default episodes.

In light of these observations, we study the link between government default and financial fragility by building a model where government default is non-discriminatory.² We use the model to address two questions. First, how does the banking system become exposed to government bonds and how does this shape the domestic costs of default? Second, how do financial institutions such as investor rights and corporate governance shape the domestic costs of default by affecting the workings of a country's banking sector? Some evidence suggests that public default risk is lower in more developed financial systems (Reinhart et al. (2003), Kraay and Nehru (2006)), but the specific mechanism for why this is the case is not yet understood.

Our model yields the following answers. First, domestic banks in our setup optimally choose to hold public bonds as a way to store liquidity (Holmström and Tirole (1993)) for financing future investments. Public bonds are useful for this purpose because the government's incentive to repay them is highest when investment opportunities are most profitable. Given this arrangement, the government's decision to default involves a trade-off. On the one hand, default beneficially increases total domestic resources for consumption, as some public bonds are held abroad. On the other hand, a default dries up the liquidity of domestic banks that also hold a share of public bonds, thereby reducing credit, investment, and output. When financial institutions are sufficiently developed, this second effect becomes so strong that the government finds it optimal to repay its debt in order to avoid inflicting losses on the domestic banking system.

This last point warrants some discussion. In our model, more developed financial institutions increase a country's cost of default through two effects. First, more developed institutions boost the leverage of banks. Higher leverage allows banks to finance a higher level of real investment, but – most importantly – it amplifies the impact of adverse shocks to their balance sheets. Hence, whenever governments default and banks hold government bonds, the ensuing disruption in real activity will be larger in those countries in which better institutions allow banks to be more leveraged. Second, for a given amount of public debt, better institutions allow the country's private sector to attract more foreign financing. Larger capital inflows to the country's private sector, in turn, increase the cost of default for the government by allowing: (i) domestic banks to further

boost leverage, and, (ii) domestic agents to hold more public debt, reducing the share of such debt that is externally held.

The key insight of our model is that financial institutions generate a complementarity between public borrowing and private credit markets. In our model, strong financial institutions foster private credit markets by allowing banks to expand their borrowing both domestically and abroad. This, in turn, reduces the government’s incentive to default, thereby facilitating public borrowing as well. By contrast, the inability of institutionally weak countries to steadily support private credit boosts public default risk, reducing credit and output. As we discuss in Section II.C, this complementarity, which is absent from existing models of sovereign risk, can shed light on the synchronization of booms and busts in the private and public financial sectors (Reinhart and Rogoff (2011)).

In Section III, we examine whether the empirical evidence is consistent with the model’s predictions. We do so by documenting the link between government defaults and domestic financial markets, on which there has been little systematic evidence produced to date.³ We build a panel of emerging and developed countries across the years 1980 to 2005. We measure the quality of financial institutions by using the “creditor rights” score of La Porta et al. (1998), which is the leading institutional predictor of credit markets development around the world (Djankov et al. (2007)). Among other things, we control for country fixed effects – that is, for all time-invariant differences among countries that may be spuriously associated with financial institutions – as well as for major domestic and external economic shocks. We first document that public defaults are followed by large drops in aggregate financial activity in the defaulting country. While consistent with our model, this finding is also consistent with the possibility that public defaults may themselves be caused by a prior, persistent weakening of private markets due, for instance, to banking crises (Reinhart and Rogoff (2011)). Our results, however, survive after controlling for such crises and for ex-ante public-default risk (using both investors’ risk assessments and propensity scores methods), which suggests that defaults may in fact directly hurt domestic financial markets over and above the role of prior banking crises and investors’ expectations.

Most importantly, the data support three subtler “differences-in-differences” predictions of our model. First, post-default declines in private credit are stronger in countries where banks hold more public debt, which is naturally consistent with our assumption of non-discriminatory default and

hard to reconcile with canonical models of perfect discrimination or external penalties. Second, such post-default declines in credit are more severe in countries where financial institutions are stronger and in countries that receive more foreign capital, which is consistent with the mechanism of complementarity. In line with these findings, the data also show that the probability of public default is lower in countries where financial institutions are stronger, where intermediaries hold more public debt, and where capital inflows are larger.

This paper extends the work on sovereign debt by emphasizing the role of domestic financial markets in reducing the government's temptation to default on its outstanding debt. In the context of recent events, our model most accurately captures a "Greek-style" crisis in which the distressed state of public finances triggers fragility in the private banking sector. Acharya, Drechsler, and Schnabl (2013) study the opposite extreme of an "Irish-style" crisis where public debt rises to troublesome levels because the government guarantees the private debt of banks following a banking crisis. We view these two approaches as being complementary. On the one hand, recognizing the presence of an explicit or implicit guarantee can help shed light on cases in which private debt crises lead to sovereign defaults. On the other hand, maintaining such a guarantee typically requires governments to tap financial markets in the short run, which in turn leads back to the question of why governments have the incentive to repay their debts in the first place. Combining both ingredients is beyond the scope of our paper but is an interesting avenue for future research.

Our approach is related to two strands of research. The first strand studies sovereign debt repayment under the assumption of non-discriminatory default. Broner and Ventura (2011) construct a model where a default on foreigners disrupts risk sharing among domestic residents. Guembel and Sussman (2009) consider a political economy mechanism for debt repayment under non-discrimination. Brutti (2011) studies a setting that is related to ours, where default destroys firms' ability to insure against idiosyncratic shocks. Basu (2009) builds a model where the government trades off the consumption gain arising from default with the cost of destroying banks' capital; in his model, however, banks' bondholdings are imposed by the government rather than being optimally chosen. Crucially, in both Basu (2009) and Brutti (2011) default reduces investment by directly reducing the net worth of ultimate investors, be they banks or entrepreneurs, while leaving financial intermediation unaffected. By considering the impact of default on financial intermediation, our model allows us to study the role of financial institutions and private capital flows. Bolton and

Jeanne (2011) have recently used a setup that is very similar to ours to study the role of banks in transmitting the effects of public defaults across financially integrated economies. Our paper is also related to Sandleris (2009), who builds a model in which public defaults – even if discriminatory – lead to output losses because they send a negative signal regarding the state of the economy.

The second strand of research examines the effect of private contracting frictions on capital flows (e.g., Gertler and Rogoff (1990), Caballero and Krishnamurthy (2001), Matsuyama (2004), and Aoki et al. (2009)). In these works financial institutions affect foreign borrowing by determining the share of output that domestic residents can credibly pledge to foreign investors. However, these works do not explicitly consider the role of public debt or the government’s default decision. In our model, instead, private contracting frictions endogenously affect the government’s willingness to repay its debts. In the language of Caballero and Krishnamurthy (2001), we endogenize a country’s external collateral constraint as a function of its domestic collateral constraint.

The paper proceeds as follows. Section I presents the basic model. Section II studies the open economy case. Section III presents the empirical evidence, and Section IV concludes. The Appendix contains proofs and extensions.

I. The Basic Model

A. Setup

A.1. Preferences and Technology

There is a small open economy (Home) that lasts for three periods $t = 0, 1, 2$. The economy is populated by a measure one of agents and by a benevolent government. There is an international financial market that is able and willing to lend or borrow any amount at an expected return equal to the (gross) interest rate r_t^* . We assume initially that $r_t^* = 1$ for all $t = 0, 1, 2$.

Residents of Home (“domestic residents”) are risk neutral and indifferent between consumption in the three dates. A fraction β of them consists of “banks” or “bankers,” denoted by B , while the remaining fraction $(1 - \beta)$ consists of “savers,” denoted by S . All domestic residents receive an endowment from the economy’s “traditional sector” equal to $\omega_0 < 1$ at $t = 0$ and to $\omega_{1j} > 1$ at $t = 1$, for $j \in \{S, B\}$. We assume that $\omega_{1B} > \omega_{1S}$ and use $\omega_1 = \beta \cdot \omega_{1B} + (1 - \beta) \cdot \omega_{1S} > 1$ to

denote the total endowment of Home at $t = 1$.

In addition to receiving their endowments, domestic residents have access to a linear investment project at $t = 1$ in the economy's "modern sector." This project yields A_j units of the consumption good at $t = 2$ per unit invested at $t = 1$, for $j \in \{S, B\}$. Bankers are more productive than savers, i.e., $A_B \geq 1 = A_S$ (for simplicity, only banks generate a social surplus). This difference in productivity, which could be due to a greater ability of banks to monitor projects (e.g., Diamond (1984)), creates a benefit for savers to lend resources to bankers so that they can be productively invested. Productivity A_B is stochastic and becomes known at the beginning of $t = 1$, taking value $A^H > 1$ with probability $p \in (0, 1)$ and $A^L = 1$ with probability $(1 - p)$. This allows us to study the cyclical properties of public default. We use $\pi \in \{H, L\}$ to index the state of productivity.

At $t = 0$ there is an indivisible investment of size 1 that the government must undertake. To finance this investment, the government taxes domestic residents with a lump sum. Since $\omega_0 < 1$, however, the public investment requires borrowing from foreigners at $t = 0$.

A.2. Financial Markets

To finance the public project at $t = 0$ and investment at $t = 1$, the government and bankers respectively need to borrow. They do so by issuing one-period, non-contingent financial claims. We refer to all claims issued by banks as deposits (d) and to claims issued by the government as public bonds (b). Thus, our notion of deposits represents all borrowing by banks, including borrowing through bond issuance. We use b_j and d_{jt} to respectively denote the holdings, by agents of type $j \in \{S, B\}$, of public bonds and of deposits originated at time $t \in \{0, 1\}$: when $d_{jt} < 0$, agents of type j are issuers of deposits. We denote by r_b the (gross) contractual interest rate promised by public bonds and by r_{dt} the (gross) contractual interest rate promised by deposits originated at t . Because public bonds are only issued at $t = 0$, none of the variables associated to them require a time subscript.

Although all claims in our economy are in principle non-contingent, they are subject to enforcement frictions that effectively make them contingent on full or partial default. Crucially, these frictions are different for deposits and public bonds. Public bonds are subject to public default risk. That is, the government opportunistically decides which fraction of its maturing bonds to repay at

$t = 1$. Since the government is benevolent, its repayment decision seeks to maximize the welfare of domestic residents. By contrast, private deposits are subject to imperfect court enforcement: if a bank defaults, only a share α of its revenues is seizable by depositors. If $\alpha = 1$, the bank can pledge all of its revenues to depositors and financial frictions are non-existent. These frictions rise as α falls below 1. The level of α captures the quality of financial institutions and, in particular, the strength of investor protection at home. Since deposits in our model reflect all borrowing by banks, the financial friction α is assumed to apply equally to all such borrowing regardless of its source. We could have also allowed, like Gertler and Kiyotaki (2010), for the severity of the financial friction to be different for different types of borrowing.

The structure of enforcement frictions here departs from the traditional sovereign risk literature, which either focuses only on public debt (e.g., Eaton and Gersovitz (1981)) or assumes that the enforcement of private contracts is entirely dependent on a strategic decision of the government (e.g., Broner and Ventura (2011)). Our assumption can be thought of as capturing an intuitive pecking order in which it is easier for governments to default on public debt rather than to disrupt domestic legal institutions.⁴

Under these enforcement frictions, the payments delivered by public bonds and deposits originated at $t = 0$ may be ex-post contingent on the state of productivity $\pi \in \{H, L\}$. Taking this into account, and letting $\rho^\pi \leq 1$ denote the share of its contractual obligations that the government decides to repay in state $\pi \in \{H, L\}$, we use $r_b^\pi = \rho^\pi \cdot r_b$ to denote the (gross) ex-post return on government bonds. Likewise, we denote by $r_{d0}^\pi(\rho^\pi) \leq r_{d0}$ the ex-post return on bank deposits originated at time $t = 0$, where we take into account that this ex-post return may be affected by public default. We use $r_0 = E_0(r_{d0}^\pi)$ to denote the expected return on these deposits. As for deposits originated at $t = 1$, they are not subject to any uncertainty and hence there is no difference between their ex-ante and ex-post returns, both of which we denote by r_{d1}^π . Note that all of these returns are specified independent of the identity of the assets' holder. This is because, despite being subject to different enforcement frictions, both public bonds and deposits are enforced in a non-discriminatory fashion. The timing of the model is described below.

1. $t = 0$: Domestic residents receive ω_0 . Financial markets open. Public bonds are issued and banks accept deposits from savers. Given the respective contractual interest rates r_b , r_{d0} ,

and r^* on government bonds, deposits, and foreign bonds, agents optimally determine their portfolio. If possible, the public investment is undertaken.

2. $t = 1$: The state of productivity $\pi \in \{H, L\}$ is revealed. Domestic residents receive ω_{1j} , $j \in \{B, S\}$. All promises issued at $t = 0$ mature. The government chooses what share $\rho^\pi \in [0, 1]$ of its outstanding obligations $r_b \cdot b$ to repay, where b denotes the total amount of bonds issued by the government. Repayment is financed via lump-sum taxation τ , where

$$\tau(b, \rho^\pi) = \rho^\pi \cdot r_b \cdot b, \quad (1)$$

so that a default ($\rho^\pi < 1$) is associated with a lower taxation of domestic residents. Financial markets open, promises are issued, and modern-sector investment is determined.

3. $t = 2$: Output is realized and promises issued at $t = 1$ mature.

[Figure 1 about here]

The main feature of our timing is that when the government decides whether or not to repay its debt, banks have not yet issued new deposits. Moreover, as captured by Equation (1), we assume that government policy is non-discriminatory with respect to both default and taxation: this assumption can be justified by the fact that public bonds are actively traded in secondary markets, which effectively makes discrimination difficult, as we also discuss formally in Section G in the Appendix.⁵ Because of its timing and its non-discriminatory nature, it is possible that the government's repayment decision affects financial markets and investment. This possibility lies at the heart of our story.

We now analyze the equilibrium of our economy. We first consider a hybrid, financially closed economy in which the government can sell bonds to foreign and domestic residents but the latter cannot borrow or lend internationally. This is done mostly for pedagogical reasons, as it provides a useful benchmark that enables us to isolate the effects of private capital flows when we move to the case of an open economy in Section II.

A competitive equilibrium of our economy is a set of portfolio decisions by agents, a government repayment decision, and a set of expected and ex-post returns on assets such that (i) given asset returns, portfolio decisions are optimal; (ii) asset markets clear; (iii) expected returns on public

bonds are consistent with government optimization at the time of enforcement; and (iv) expected returns on deposits are consistent with imperfect enforcement. We focus throughout on symmetric equilibria, in which all agents of the same type hold the same portfolio.

B. Equilibrium in Deposit Markets

We first characterize the equilibrium in deposit markets, without reference to the government's repayment decision, starting with the market at $t = 1$ and then working our way back to study the market at $t = 0$. We then consider the government's default decision.

B.1. Equilibrium in the Deposit Market at $t = 1$

Let W_j^π be the wealth of an individual of type $j \in \{B, S\}$ when financial markets open at $t = 1$ and the state is π ; this includes the individual's endowment plus any payments obtained/made from assets purchased/issued at $t = 0$. Upon learning A^π at $t = 1$, a bank entering the period chooses its level of deposits d_{B1} by solving:

$$\max_{d_{B1}} A^\pi \cdot (-d_{B1} + W_B^\pi) + r_{d1}^\pi \cdot d_{B1} \quad \text{subject to,} \quad (2)$$

$$-d_{B1} \cdot r_{d1}^\pi \leq \alpha \cdot A^\pi \cdot (-d_{B1} + W_B^\pi) \quad \text{for } d_{B1} < 0, \quad (3)$$

for $\pi \in \{H, L\}$, where Equation (3) represents the bank's credit constraint. The equilibrium interest rate on deposits must be lower than the productivity of investment, i.e., $r_{d1}^\pi \leq A^\pi$, since otherwise banks would not want to attract any deposits. It must also be true that $r_{d1}^\pi > \alpha \cdot A^\pi$, since otherwise a bank could attract an infinite amount of deposits. Under these conditions, the banking system's demand of funds at $t = 1$ is given by

$$\beta \cdot \frac{\alpha \cdot A^\pi}{r_{d1}^\pi - \alpha \cdot A^\pi} \cdot W_B^\pi, \quad (4)$$

and aggregate investment by the banking system is in turn given by,

$$I^\pi(W_B^\pi) = \beta \cdot \frac{r_{d1}^\pi}{r_{d1}^\pi - \alpha \cdot A^\pi} \cdot W_B^\pi. \quad (5)$$

Equations (4) and (5) show that greater investor protection α enhances the ability of banks to leverage their wealth, attracting more deposits and expanding their investments at $t = 1$.

The supply of funds at $t = 1$ depends on the wealth of savers. If $r_{d1}^\pi > 1$, savers are willing to lend all of their wealth $(1 - \beta) \cdot W_S^\pi$ to banks. If $r_{d1}^\pi = 1$, savers are indifferent between lending and not lending, and their supply of funds is given by the interval $[0, (1 - \beta) W_S^\pi]$.

Given the above demand and supply of funds at $t = 1$, there are two types of equilibria in the deposit market. In the first type, deposits at $t = 1$ are constrained by banks' ability to absorb savings: in such an equilibrium, $r_{d1}^\pi = 1$ and the demand for funds in Equation (4) falls short of the supply. Modern-sector investment is constrained by banks' wealth, yielding a social surplus of

$$(A^\pi - 1) \cdot \beta \cdot \frac{1}{1 - \alpha \cdot A^\pi} \cdot W_B^\pi. \quad (6)$$

This type of equilibrium arises when $\alpha \leq \alpha^{\max}$, where α^{\max} is defined as

$$\alpha^{\max}(\beta; \pi) = \frac{(1 - \beta) \cdot W_S^\pi}{A^\pi \cdot [\beta \cdot W_B^\pi + (1 - \beta) \cdot W_S^\pi]}. \quad (7)$$

The second type of equilibrium corresponds instead to the case in which investor protection is very strong, i.e., $\alpha > \alpha^{\max}(\beta; \pi)$, and banks are capable of absorbing all domestic wealth to invest it in the modern sector. Now the social surplus of this investment equals

$$(A^\pi - 1) \cdot [\beta \cdot W_B^\pi + (1 - \beta) \cdot W_S^\pi]. \quad (8)$$

Inspection of Equations (6) and (8) shows that social surplus is positive only if $\pi = H$ so that $A_B = A^H > 1$, and it also allows us to establish the following preliminary result:

LEMMA 1: If $\alpha \leq \alpha^{\max}$, investment is constrained by banks' wealth. In this case, modern-sector surplus is increasing in banks' wealth W_B^π and in investor protection α . If $\alpha > \alpha^{\max}$, modern-sector surplus is constrained only by total domestic wealth, and it is independent of α .

The key point of this section is that, as long as $\alpha \leq \alpha^{\max}$, investment is limited by banks' ability to borrow. In this range, higher bank capital, better investor protection, and a larger banking sector reduce the severity of financial frictions, expanding investment and surplus. Crucially, the wealth

of banks, W_B^π , and that of savers, W_S^π , as well as the need for intermediation at $t = 1$, depend on the equilibrium portfolios at $t = 0$ and on the government's repayment decision at $t = 1$. We study these below.

B.2. Equilibrium in the Deposit Market at $t = 0$

At $t = 0$, any deposits raised by banks can only be invested in public bonds. Since these bonds must be attractive to the international financial market, their expected return must satisfy $E_0(r_b^\pi) = r^* = 1$. If the expected interest rate on deposits also equals 1, i.e., $r_0 = 1$, savers are indifferent between holding public bonds and bank deposits; if instead $r_0 > 1$, savers deposit all of their initial endowment $(1 - \beta) \cdot \omega_0$ in banks.

Consider now a bank that raises $-d_{b0} = (b_B - \omega_0)$ in the deposit market at $t = 0$ to purchase a total of b_B public bonds. Due to enforcement frictions, any such bank must satisfy:

$$r_0 \cdot (b_B - \omega_0) \leq \alpha \cdot (\omega_{1B} + b_B), \quad (9)$$

where we have taken into account the fact that $E_0(r_b^\pi) = 1$. By Equation (9), expected payments on deposits cannot exceed a share α of the bank's expected revenues at $t = 1$. If a bank demands the maximum amount of bonds allowed by Equation (9), its bondholdings are equal to:

$$b_B = \min \left\{ \frac{\omega_0 + \alpha \cdot \omega_{1B}}{1 - \alpha}, \frac{\omega_0}{\beta} \right\}. \quad (10)$$

The first term in brackets captures bondholdings when deposits are constrained by the pledgeability constraint of Equation (9): in this case, banks cannot purchase all domestically held public bonds; as a result, $r_0 = 1$ and a nonnegative amount $(\omega_0 - \beta \cdot b_B)$ of public debt is held by savers.⁶ Formally, this case arises if

$$\alpha \leq \alpha_0(\beta) \equiv \frac{(1 - \beta) \cdot \omega_0}{\omega_0 + \beta \cdot \omega_{1B}}. \quad (11)$$

When instead $\alpha > \alpha_0(\beta)$, savers deposit their whole endowment in banks. In this case $r_0 > 1$ and banks use all of the economy's resources to purchase public bonds, so that $\beta \cdot b_B = \omega_0$, as shown by the second term in brackets in Equation (10).

Equation (10) holds in equilibrium only if banks actually want to hold as many bonds as

possible, i.e., if constraint (9) is binding. We now argue that this will actually be the case whenever the government is expected (i) to repay its debt if productivity is high (i.e., $A_B = A^H$), but (ii) to fully default otherwise. As we show in the next section, this strategy is indeed optimal for the government if it is ever to repay.⁷ Taking this repayment policy as given for the time being, we note that the equilibrium return of government bonds must necessarily satisfy $E_0(r_b^\pi) = 1$, since otherwise there would be no foreign demand for them. If the government is expected to default when the productivity of investment is low, it follows that investors must be appropriately compensated when the productivity of investment is high and bonds are repaid, i.e., $r_b^H = 1/p$. Thus, by borrowing from savers to buy one government bond, a bank increases its revenues by $(1/p - 1) > 0$ units in state $\pi = H$ and decreases them by 1 unit in state $\pi = L$. Given these returns, it is easy to show that banks are eager to buy public bonds. The reason is that these bonds enable banks to transfer resources from the unproductive to the productive state of nature, in which they earn rents from investment equal to $A^H - r_{dl}^H$.

This idea is reminiscent of Holmström and Tirole's (1993) notion that public debt provides liquidity, expanding firms' ability to invest. In their model, firms need liquidity when they suffer a negative idiosyncratic shock that requires them to invest, and public bonds provide such liquidity. In our model, banks need liquidity when the economy is productive and investment opportunities abound. Public bonds, with their procyclical returns, are good at providing such liquidity. This is the reason why banks in our model choose to hold bonds in equilibrium: they are essentially pursuing a carry trade, using the extra yield of public bonds to fund future investments.

In reality, of course, there are also other reasons why banks may hold government bonds. One such reason is that banks hold bonds as a buffer against idiosyncratic shocks because these bonds can be used as collateral for interbank lending or repos (see Bolton and Jeanne (2011)). Another reason is that governments may force banks to purchase and hold their bonds. Both of these reasons could be easily added to our model without changing its main results. The only thing that we require is that banks have a relatively high demand for government bonds despite the risk of default.

C. Government Default

We now analyze the government's repayment decision. After productivity $\pi \in \{H, L\}$ is realized at $t = 1$, the government chooses what share $\rho^\pi \in [0, 1]$ of its debt to repay. To understand the government's incentives, note that debt repayment affects the domestic distribution of wealth. The wealth of an agent of type $j \in \{B, S\}$ at $t = 1$ is given by,

$$W_j^\pi = \omega_{1j} + r_b \cdot \rho^\pi \cdot [b_j - b] + r_{d0}^\pi(\rho^\pi) \cdot d_{j0}, \quad (12)$$

where we have used the government's budget constraint and the fact that $r_b^\pi = \rho^\pi \cdot r_b$.

Equation (12) shows that the direct impact of government repayment ρ^π on the wealth of type- j individuals depends on their holdings of public bonds. If $b_j \geq b$, the wealth of these individuals is increasing in ρ^π because the share of the debt they own exceeds their share of the tax burden required to service the debt. Thus, for this type of agent, the benefit of government repayment is larger than the cost. The opposite is true when $b_j < b$.

Keeping this in mind, the government chooses ρ^π at $t = 1$ to maximize social welfare:

$$[\beta \cdot W_B^\pi + (1 - \beta) \cdot W_S^\pi] + (A^\pi - 1) \cdot I^\pi(W_B^\pi), \quad (13)$$

for $\pi \in \{H, L\}$, which is the sum of total domestic wealth (the first term in brackets) plus the surplus generated by modern-sector investment. The government's trade-off is straightforward. On the one hand, as long as foreigners hold some debt, default beneficially boosts the total wealth of domestic agents, i.e., the first term in Equation (13). On the other hand, if banks hold a sufficiently large amount of government bonds, default hurts the wealth of the banking system, reducing modern-sector investment and lowering the second term of Equation (13). By redistributing wealth away from banks, a government default may ultimately reduce investment and output.

Of course, for this redistribution to be costly, investment must be productive. As a result, repayment never occurs in the low productivity state when $A_B = A^L = 1$, i.e., $\rho^L = 0$. If the government is ever to repay, it only does so when productivity is high, i.e., when $A_B = A^H > 1$, implying that in such a state the government must pay an interest rate $r_g^H = 1/p$.⁸ Because of this, we focus exclusively on state $\pi = H$ from now on, using $\alpha^{\max}(\beta)$ to denote the level $\alpha^{\max}(\beta; H)$

of investor protection beyond which all domestic wealth is intermediated by banks when $\pi = H$.

Suppose then that productivity is high at $t = 1$, i.e., $A_B = A^H > 1$. Focus first on the case where $\alpha \leq \alpha^{\max}(\beta)$, so that $r_{d1}^H = 1$ and investment is constrained by banks' wealth. Public debt here is sustainable when the government finds it optimal to repay, setting $\rho^H = 1$. By using the definition of W_B^H from Equation (12), we see that – as long as $\alpha \leq \alpha_0$ and some bonds are in the hands of savers – this is the case if:

$$(\omega_0 - 1) + \frac{A^H - 1}{1 - \alpha \cdot A^H} \cdot \beta \cdot (\omega_0 + \alpha \cdot \omega_{1B} - 1) \geq 0, \quad (14)$$

where $\omega_0 + \alpha \cdot \omega_{1B}$ reflects the bondholdings of banks b_B from Equation (10).⁹ The first term in Equation (14) is negative, and it captures the decline in total domestic resources caused by repayment. The second term instead captures the impact of repayment on the after-tax revenue of banks and thus on investment. This term is positive as long as the bondholdings of banks are high enough, i.e. $\omega_0 + \alpha \cdot \omega_{1B} > 1$. Clearly, this is a necessary condition for public debt to be sustainable.

As long as this condition holds, Equation (14) shows that incentives to repay increase in investor protection α . There are two reasons for this. First, for a given amount of banks' bondholdings, higher levels of α enable banks to increase their leverage to expand modern-sector investment. Consequently, the adverse impact of default on investment increases in α , as captured by the multiplier $1/(1 - \alpha \cdot A^H)$ above. This is the key effect of the model. Second, higher α enhances debt sustainability by increasing banks' ability to raise deposits to buy public bonds at $t = 0$, thus increasing banks' exposure to a public default. This second effect is not necessary for our results, but it makes them stronger. When these effects are jointly considered, Equation (14) defines a minimum level of investor protection $\alpha^{\min}(\beta)$ that is necessary for public debt to be sustainable. The shaded area in Figure 2 depicts the combinations (α, β) for which $\alpha > \alpha^{\min}(\beta)$:

[Figure 2 about here]

Note that $\alpha^{\min}(\beta)$ is non-monotonic in the share of bankers β . If $\beta \rightarrow 0$, incentives for repayment are only provided if α is high so that the few existing banks (i) hold a disproportionately high share of public bonds and (ii) are highly leveraged. If instead $\beta \rightarrow 1$ and everyone is a banker, in-

stead, there is no way in which debt repayment can raise the wealth of banks: in this case, defaults are necessarily beneficial from the government's perspective. Intuitively, public debt sustainability requires defaults to generate a sizeable and undesired redistribution, away from bankers (i.e. bondholders) to taxpayers. Clearly, this redistribution cannot be sizeable if no one is a banker or if everyone is.

So far, all of our results have been derived under the assumption that $\alpha \leq \alpha^{\max}(\beta)$. Consider now the other relevant case, in which $\alpha > \alpha^{\max}(\beta)$ and investment at $t = 1$ is constrained not by the wealth of banks but by the total wealth of domestic agents. In this case, the government's first-order condition becomes

$$A^H \cdot (\omega_0 - 1) < 0, \quad (15)$$

which is always negative because some of the public bonds are held abroad, as $\omega_0 < 1$. Thus, when $\alpha > \alpha^{\max}(\beta)$, the government never has an incentive to repay in full, and so the optimal level of public debt $b = 1$ is not sustainable. Intuitively, even if default hurts the balance sheets of banks, it also increases total domestic wealth by $(1 - \omega_0)$. If the domestic financial system is efficient enough to channel all of these resources to the modern sector, a public default boosts investment even though it hurts banks. Figure 3 summarizes our discussion by shading the combinations (α, β) for which the optimal level of debt is sustainable.

[Figure 3 about here]

The Proposition below states the conditions for debt sustainability in the closed economy:

PROPOSITION 1: *In the closed economy, the government can finance the public project if and only if (α, β) is such that $\alpha \in [\alpha^{\min}(\beta), \alpha^{\max}(\beta)]$. In this case, the government borrows at a contractual rate equal to $r_b = 1/p$, and it repays if and only if $A_B = A^H$. The set of combinations (α, β) fulfilling the previous condition is non-empty if $p > p^*$, where p^* is a given threshold.*

Proof. See Appendix. □

D. Discussion

As in many sovereign debt crises, a government default in our model hurts domestic banks because they hold public bonds in equilibrium. Because of non-discriminatory enforcement, the government is unable to avoid the costs of default by repaying only those bonds in the hands of the banking system while defaulting on the rest. Because of non-discriminatory taxation, the government is unable to avoid the costs of default by bailing out the banking system through direct subsidies. Admittedly, our assumption that no degree of discrimination is possible is extreme. However, our mechanism would still stand if we allowed some degree of discrimination on enforcement and taxation policies: all that we need is for discrimination to be limited enough to prevent a full undoing of the costs associated with public defaults.

To see this, consider a simple extension of our model in which, in the event of a default, banks receive a compensation for a fraction $\theta \in [0, 1]$ of their defaulted bonds. This compensation is financed through non-discriminatory lump-sum taxation. Such a scheme, which amounts to a partial bailout of banks, affects the wealth of a representative bank in Equation (12) in two ways: it increases the bank's income from defaulted bonds to $r_b \cdot \theta \cdot (1 - \rho^\pi) \cdot b_B$, and it raises its tax bill by $r_b \cdot \theta \cdot (1 - \rho^\pi) \cdot \beta \cdot b_B$.

Under this scheme, the government's first-order condition of Equation (14) becomes

$$(\omega_0 - 1) + \frac{A^H - 1}{1 - \alpha \cdot A^H} \cdot \beta \cdot [(1 - \theta(1 - \beta)) \cdot (\omega_0 + \alpha \cdot \omega_{1B}) - 1] \geq 0. \quad (16)$$

When the government cannot bailout banks, $\theta = 0$ and Equations (14) and (16) coincide. As the ability to bail out increases (as θ rises), the benefit of repayment in Equation (16) falls. Eventually, if θ becomes sufficiently high, the government is able to fully compensate banks for their losses and it thus always chooses to default. Crucially, the government still has an incentive to repay as long as its ability to bail out banks is imperfect (i.e., θ is sufficiently low).

In our model the costs of default are thus shaped by financial institutions via two conflicting effects. On the one hand, higher levels of α enhance banks' leverage, boosting the adverse effects of public defaults on investment.¹⁰ On the other hand, once financial institutions are very good, banks cease to be financially constrained, and they are always able to intermediate all domestic wealth and direct it to investment. Although it provides a useful conceptual benchmark, this second

effect is unlikely to be important in reality. First, the levels of α required for it to play a role may be implausibly high. As recent events have shown, financial constraints are important even in the most developed financial systems. More significantly, we now show that this second effect may fail to operate due to the presence of private capital flows. To see this, we extend our model to the more realistic case of an open economy and use it to derive our main empirical predictions.

II. The Open Economy: Private and Public Capital Flows

Suppose that the capital account of our economy opens up, allowing private agents to borrow from and lend to the international financial market at $t = 0$ and $t = 1$. The effects of private capital flows are best analyzed by considering two cases. In the first case, $r^* = 1$ and the domestic economy is (weakly) an importer of private capital. In the second case, $r^* > 1$ and the domestic economy may (but need not) become an exporter of private capital.¹¹

A. The Case of Capital Importers

If the world interest rate is equal to 1 at all dates ($r_0^* = r_1^* = 1$), opening up to private flows relaxes the domestic resource constraint at $t = 0$ and at $t = 1$. Both of these effects, we now argue, enhance the sustainability of public debt.

At $t = 1$, private inflows enable domestic banks to boost leverage by attracting deposits also from international financial markets. Investment is no longer constrained by total domestic wealth. Formally, this implies that investment is monotonically increasing in α , which eliminates the constraint represented by $\alpha^{\max}(\beta)$. From the viewpoint of $t = 0$, moreover, private inflows enable bankers and savers to expand their holdings of public bonds by borrowing abroad: essentially, the domestic private sector can intermediate between its government and foreigners. This boosts the government's incentive to repay ex-post, shifting down the constraint represented by $\alpha^{\min}(\beta)$.

Formally, the condition for debt sustainability in the open economy when $r^* = 1$ is equal to

$$(\omega_0 + \alpha \cdot \omega_1 - 1) + \frac{A^H - 1}{1 - \alpha \cdot A^H} \cdot \beta \cdot (\omega_0 + \alpha \cdot \omega_{1B} - 1) \geq 0. \quad (17)$$

In comparison to Equation (14), the first term above reflects the fact that domestic holdings of

public bonds can now exceed ω_0 . The reason is that domestic residents can borrow against their future endowment ω_1 from the international financial market in order to purchase bonds. Likewise, the expression in parentheses in the second term reflects the fact that a bank's bondholdings now equal its pledgeable endowment $\omega_0 + \alpha \cdot \omega_{1B}$. Trivially, public debt is always sustainable once α is large enough to satisfy $\alpha \cdot \omega_1 \geq 1 - \omega_0$ because now foreign borrowing allows domestic residents to purchase all public bonds and sustainability is guaranteed. Equation (17) implies the following:

PROPOSITION 2: *When $r_0^* = r_1^* = 1$, there exists a threshold $\alpha_{open}^{\min}(\beta) < \alpha^{\min}(\beta)$ such that the government can finance the public project for all combinations (α, β) for which $\alpha \geq \alpha_{open}^{\min}(\beta)$.*

Proof. See Appendix. □

In addition to their direct effect on private investment, capital inflows are therefore beneficial for public debt sustainability as well. By expanding investment at $t = 1$ and domestic holdings of public bonds at $t = 0$, these inflows make default more costly. The darker area in Figure 4 shows how private inflows expand the set of economies for which the public project is financed:

[Figure 4 about here]

B. The Case of Capital Exporters

Consider now the case of a capital exporter, for which the autarky interest rate lies below r^* . We keep matters simple by assuming that $r_0^* = 1$ but $r_1^* \in (1, A^H)$.¹² In equilibrium, it is still true that $E_0(r_b^\pi) = E_0(r_{d0}^\pi) = 1$, but now the domestic interest rate at $t = 1$ equals r_1^* . As in the previous section, the ability of banks to attract deposits from the foreigners at $t = 1$ eliminates the constraint represented by $\alpha^{\max}(\beta)$ and the condition for debt sustainability becomes

$$(\omega_0 + \alpha \cdot \omega_1 - 1) + \frac{A^H - r_1^*}{r_1^* - \alpha \cdot A^H} \cdot \beta \cdot (\omega_0 + \alpha \cdot \omega_{1B} - 1) \geq 0. \quad (18)$$

As in Equation (17), all domestic residents can now increase their total purchases of public bonds at $t = 0$ by borrowing abroad, which enhances debt sustainability. However, insofar as it leads to an increase in the equilibrium interest rate at $t = 1$, financial liberalization also induces capital outflows and reduces bank leverage and investment. This reduction in the leverage of domestic

banks, in turn, attenuates the negative effects of public defaults on investment. Through this last effect, financial liberalization may decrease debt sustainability. Formally:

PROPOSITION 3: Let $\alpha_{open}^{\min}(\beta, r_1^*)$ be defined as the smallest level of α satisfying Equation (18), for $\beta \in (0, 1)$. There exists a threshold $\underline{r} \in (1, A^H)$ such that $\alpha_{open}^{\min}(\beta, r_1^*) > \alpha^{\min}(\beta)$ whenever $r_1^* > \underline{r}$.

Proof. See Appendix. □

Proposition 3 is most interesting when it is applied to economies where $\alpha \in [\alpha^{\min}(\beta), \alpha^{\max}(\beta)]$. These are economies where α is sufficiently low so that, in the absence of financial liberalization, $r_{d1}^H = 1$. Provided the international interest rate r_1^* is high enough, financial liberalization reduces debt sustainability in these economies, as shown in Figure 5.

[Figure 5 about here]

Liberalization lowers the cost of default in countries with a low autarky interest rate by inducing private capital outflows from these countries. This possibility increases the minimum level of institutional quality $\alpha_{open}^{\min}(\beta)$ at which public debt is sustainable. As a result, the government of a capital-exporting economy may benefit from imposing controls to prevent such outflows. Beyond yielding a direct benefit when the return to domestic investment is higher than the international interest rate ($A_B > r_1^*$), such controls indirectly enhance public debt sustainability.

C. Discussion and Empirical Predictions

In our model, public and private borrowing complement each other.¹³ On the one hand, higher domestic or external borrowing by banks raises the costs of defaults for the government, thereby reducing the risk of public defaults. Because of this, an improvement in financial institutions raises a country's ability to access foreign funds not only directly – by stimulating private borrowing – but also indirectly by raising the sustainability of public borrowing. On the other hand, the government's borrowing and default decisions affect private borrowing as well. This is certainly true ex-post, as public defaults hinder the ability of private banks to borrow. But our model shows that this is also true from an ex-ante perspective, in the sense that the mere existence of public debt

helps increase private intermediation. The reason is that public bonds provide a valuable liquidity service to the banking system, which is exactly why banks chose to hold bonds in the first place. As a result, any exogenous factor limiting the government’s ability to issue debt (e.g., an exogenous increase in public default risk) also reduces the expected size of private financial markets.¹⁴

This complementarity between public and private borrowing can shed light on Reinhart and Rogoff’s (2010) account of international lending patterns. Their account shows that during capital flows “bonanzas” there is a run up in both private and public debt that gives way, as financial markets deteriorate, to public defaults, banking crises, and credit crunches. Complementarity can rationalize both the mutually reinforcing nature of private and public borrowing booms as well as the spread of crises across both types of borrowing.

In the context of financial crises, our model yields two sets of predictions. First, any shock disrupting private credit markets should increase the likelihood of government default. For instance, a drop in the size of the banking sector β – capturing a banking crisis – will reduce the government’s incentive to repay in Equation (14). The same is true for an increase in the international interest rate r_1^* , which reduces leverage in the banking sector.¹⁵ Second, a crisis initiated by a sovereign default should cause a drop in private intermediation, the extent of which should depend on the specific features of domestic credit markets. To see this formally, let PC_1 denote the volume of private credit at $t = 1$, which is equal to the volume of bank deposits in Equation (4). By using the definition of banks’ wealth in Equation (12), we obtain our most immediate prediction:

COROLLARY 1: *Public default should reduce private credit:*

$$\frac{\partial PC_1}{\partial \rho^\pi} = \beta \cdot \frac{\alpha \cdot A_\pi}{r_1^* - \alpha \cdot A_\pi} (b_B - 1) > 0. \quad (19)$$

Comparing two otherwise identical economies, the one in which the government defaults should have lower private credit than the one where the government repays.¹⁶ Canonical sovereign debt models may yield this prediction as an indirect effect of the government’s exclusion from financial markets. Equation (19), however, also implies two subtler predictions of our model, which stress the role of private financial intermediation:

COROLLARY 2: *The post-default contraction in private credit should be stronger in countries with:*

(i) better financial institutions, as $\partial^2 PC_1 / \partial \rho^\pi \partial \alpha > 0$, and (ii) higher holdings of public debt by domestic banks, as $\partial^2 PC_1 / \partial \rho^\pi \partial b_B > 0$.

Given an amount of bondholdings b_B , Equation (19) shows that better institutions increase the post-default decline in private credit by increasing banks' leverage as captured by the multiplier $\alpha \cdot A_\pi / (r_1^* - \alpha \cdot A_\pi)$. At the same time, greater values of b_B result in more severe post-default declines in credit because they increase the vulnerability of banks' balance sheets to public defaults. Although intuitive, this last prediction is at odds with canonical models where the government can perfectly shield domestic agents from sovereign defaults. Propositions 1 and 2 directly yield an additional prediction of our model: the post-default declines in credit should be stronger if the country borrows more from foreigners. This is because foreign capital increases leverage in the domestic financial sector.

These predictions translate directly into implications for ex-ante default risk. Suppose that an indebted government faces an unexpected increase in the international interest rate r_1^* at $t = 1$. Such a shock may or may not cause a default depending on whether, at the new interest rate, the government's first-order condition (i.e., either Equation (17) or (18)) is met. This implies the following:

COROLLARY 3: *The frequency of default should be (weakly) lower in countries with: (i) better financial institutions, i.e., higher α , and (ii) higher holdings of public debt by domestic banks b_B .*

Intuitively, in these countries the cost of default is higher at any interest rate r_1 , as illustrated by the fact that the government's first-order conditions are more likely to be slack. In line with the previously discussed role of capital inflows in enhancing the post-default declines in credit, our model also naturally predicts that the probability of default should be lower if a country borrows more from foreigners.

We now examine whether the data is consistent with the view that public defaults have an adverse impact on private credit as described in Corollaries 1, 2, and 3. We also examine whether private external borrowing has an effect on the severity of the post-default declines in credit and on the ex-ante risk of default. Although the reverse channel – the impact of credit market shocks on public defaults – is also consistent with our model, complementarity ultimately requires that public defaults disrupt private markets. This is why we focus on the direct channel going from

public defaults to private markets. While it is beyond the scope of the next section to formally test our model and fully establish causality, we provide the first systematic evidence on the link between public default, bondholdings, and private credit.

III. Empirical Analysis

In Section III.A we examine the raw data concerning banks' holdings of public bonds and the link between default and credit. In Sections III.B and III.C we perform formal regression analyses on the predictions of Corollaries 1, 2, and 3 and also on the role of private capital inflows.¹⁷

We use a large panel of emerging and developed countries over the years 1980 to 2005, which we constructed by combining data from the IMF's *International Financial Statistics* (IFS) and the World Bank's *World Development Indicators* (WDI) (see Table AI in the Internet Appendix for a description of variables and sources).

To test for the link between default and domestic financial markets, we use as our main dependent variable the change in the annual ratio of private credit provided by deposit money banks and other financial institutions to GDP, which is drawn from Beck et al. (2000). This widely used measure is an objective, continuous proxy for the size of domestic credit markets.¹⁸ We focus on private credit changes – rather than levels – to control for persistence in the level of private credit. As a robustness check, we also perform our tests by using the % change in private credit as the dependent variable.

Following the existing literature, we proxy for sovereign default with a dummy variable based on Standard & Poor's definition of default as the failure of a debtor (government) to meet a principal or interest payment on the due date (or within the specified grace period) contained in the original terms of the debt issue. A debt restructuring under which the new debt contains less favorable terms to the creditors than the original issue is also counted as default, which implies that the Greek debt restructuring of March 2012 would also be counted as a default.¹⁹

We proxy for the quality of a country's financial institutions with the creditor rights index of Djankov, McLiesh, and Shleifer (2007), who compute it for 133 countries for every year between 1978 and 2003, extending the methodology of La Porta et al. (1998). This index is the leading “institutional” predictor of credit market development around the world. In our sample the raw

correlation between private credit to GDP and the creditor rights index is positive, large (24.9%), and statistically significant at the 1% level. This creditor rights index maps directly into the parameter α of our model, which captures the ability of creditors to collect from debtors. Relative to other measures that have been found to predict capital market liberalization and GDP growth (e.g., see Bekaert et al. (2005) for a discussion of measures of legal reform), it also has the advantage of being very persistent and thus less prone to endogeneity concerns. The protection of banks' creditors could be also measured using the extent of deposit insurance. We choose to use creditor rights for two reasons. First, deposit insurance protects only a subset of the bank's creditors. Second, deposit insurance is itself a form of government liability; whether the government chooses to honor it or not may depend on factors correlated with public defaults.²⁰

Finally, we proxy domestic banks' holdings of public debt with financial institutions' net claims to the government relative to their total assets, following Kumhof and Tanner (2008).

A. Basic Facts about Default, Credit, and Bondholdings

Table I reports the list of defaults in our sample indicating whether default was followed or preceded by a banking crisis.

[Table I about here]

There are 110 default episodes in 81 countries in our sample period. There is considerable variation in the duration of default episodes, ranging from 25 years in the case of the Democratic Republic of Congo, to 13 years in the cases of Poland and Peru, to one year in the case of Venezuela in 1990. Defaults have become shorter over time: those starting in the 1990s have a substantially shorter duration than those starting in the 1980s.

The evidence is consistent with Reinhart and Rogoff (2010, 2011), as defaults and banking crises in a given country tend to occur together, often within a short timespan. Table I uses the definition of banking crises given by Caprio and Klingebiel (2001) and the updated data by Caprio et al. (2005) and shows that, of all the 110 default episodes in our sample, 74 (67% of the total) were accompanied by a banking crisis. The sequencing differs across episodes. In 30 of these cases a banking crisis was ongoing or had started in the three years prior to a public default, while

in 44 of these cases it occurred in the same year or in a later year. Finally, 36 default episodes occurred in the absence of banking crises, either before or subsequently. These figures suggest that both directions of complementarity are likely at play in countries experiencing both defaults and banking crises.

We now check if the raw data support the prediction of Corollary 1: the negative impact of public default on private credit. Figure 6 plots the average change in private credit to GDP following default and no default events, as weighted by GDP (a similar figure results if we use medians). After a default in year $t - 1$, the change in private credit from $t - 1$ to t is equal to 0.32% of GDP, as compared with 2.39 for country-years following no default. These differences are large in economic terms and statistically significant at the 1% level.

[Figure 6 about here]

Consider now the subtler predictions of Corollary 2 concerning the cross-country heterogeneity in the post-default decline in credit. Figure 7 shows that the GDP-weighted change in private credit after a default is 1.25% of GDP in country-years with below-median public debt-holdings, as compared with -0.41 for country-years with above-median public debt-holdings. Similarly, the GDP-weighted change in private credit after a default is 1.01% of GDP in country-years with below-median creditor rights (i.e., creditor rights score of 0 or 1), as compared with -0.70 for country-years with above-median creditor rights (i.e., creditor rights score of 2, 3, or 4). These differences, which go in the directions predicted by our model, are large in economic terms and statistically significant at standard levels.

[Figure 7 about here]

One concern with the correlations reported in Figures 6 and 7 is that they merely reflect endogeneity. There are two main reasons for this. First, an economy-wide adverse shock may generate both a persistent decline in credit flows and a public default. This effect could produce a visual pattern similar to that of Figure 6 even if default has no direct impact on private credit. Second, some countries may be intrinsically more prone to severe public and private debt crises than others, for instance because of country-specific historical or policy factors influencing both financial development and government default. Figure 7 may thus reflect this heterogeneity in

countries' long-run characteristics rather than the effects of creditor rights or bondholdings per se. The next section makes a first attempt to partially address these issues by using standard panel estimation techniques.

Before proceeding to the estimation, however, we take a look at the raw data on banks' holdings of public bonds. Our model has implications for the link between the share of bank assets invested in public bonds and the quality of financial institutions. In the model, bank assets consist of public bonds and of loans made to firms. As both variables increase in α – see Equations (10) and (5) – better financial institutions have an ambiguous effect on the "bonds-to-assets" ratio of the banking system as a whole. In the limit, though, if financial institutions are very good, the effect of bank leverage dominates and the bonds-to-assets ratio is very low.²¹ We now look at the cross-country data, focusing for illustration purposes on within-country averages over 2001-2003.

Two features of the data immediately stand out. First, banks hold large quantities of public bonds, which on average amount to 11.8% of their total assets. Second, there is a large variation in average bondholdings across countries: for example, bondholdings in Turkey, Brazil, and Belgium are as large as 50.8%, 44.4%, and 38.2% of bank assets, respectively, while in the United States and Malaysia they are 2.9% and 1.3%, respectively. As Figure 8 shows, banks' bondholdings are lower in countries with high creditor rights (i.e., with a score of 2, 3, or 4) than in countries with low creditor rights (score of 0 or 1).²²

[Figure 8 about here]

A common rationale for these bondholdings by banks is that public bonds have a preferential status for meeting reserve requirements. To shed light on this, we collected data on reserve requirements for a subset of the countries in our sample over 2001-2003 (see O'Brien (2007) and sources therein). In our sample, banks can use various sets of assets to meet reserve requirements, and while the asset composition differs somewhat, in all countries in our sample banks can use public debt to meet reserve requirements (see Table AIII in the Internet Appendix for details). As Figure A1 in the Internet Appendix shows, across countries (i) there is no statistical link between public debt and reserve requirements, and (ii) banks often choose to hold bonds in excess of their total reserve requirement; that is, even without accounting for the other eligible assets, banks more than exceed their reserve requirements with their public bondholdings alone. Of course, governments

may induce banks to hold public bonds through subtler instruments than reserve requirements, particularly during periods of financial turbulence. However, the evidence is *prima facie* consistent with the possibility that banks may voluntarily demand public bonds, over and above those needed to meet reserve requirements, as predicted by our model.

B. Institutions, Bondholdings and the Decline in Credit

We now estimate various specifications of the pooled OLS regression:

$$\begin{aligned}
 (\text{Change in Private Credit})_{i,t} &= \alpha_i + v_t + X'_{i,t-1}\gamma + \beta_1 (\text{Sovereign Default})_{i,t-1} & (20) \\
 &+ \beta_2 (\text{Sovereign Default})_{i,t-1} \cdot (\text{Creditor Rights})_{i,t-1} \\
 &+ \beta_3 (\text{Sovereign Default})_{i,t-1} \cdot (\text{Bondholdings})_{i,t-1} + \epsilon_{i,t}.
 \end{aligned}$$

In the most basic specification, we exclude the interactive terms (imposing $\beta_2 = \beta_3 = 0$) to see whether, in line with Corollary 1, public default is on average followed by a decline in credit, namely $\beta_1 < 0$. We then include the interactive terms to see whether, in line with Corollary 2, such a decline in credit becomes worse as creditor rights and bank bondholdings increase, namely $\beta_2 < 0$ and $\beta_3 < 0$.²³ We finally include the additional interactive term $\beta_4 (\text{Sovereign Default})_{i,t-1} \cdot (\text{Private Foreign Liabilities})_{i,t-1}$ to Equation (20), where private foreign liabilities are taken from Lane and Milesi-Ferretti (2007). Again, complementarity implies that the greater the external borrowing of the domestic financial sector (the higher its Foreign Liabilities), the stronger should be the post-default credit crunch, namely $\beta_4 < 0$.

In Equation (20), the coefficient α_i represents country effects, which control for all time-invariant country-specific (e.g., historical or policy) factors affecting both private credit and sovereign defaults. The coefficient v_t captures instead time effects, controlling for common shocks across countries (e.g., changes in world interest rates). To deal with the remaining possible sources of endogeneity, namely country-specific time-varying shocks, the vector $X'_{i,t-1}$ contains lagged variables that capture the most common predictors of a decline in private credit and of public default. We include these variables in an attempt to purge our coefficient estimates of the effects of pre-existing economic conditions, at least to the extent that our data allow us to do so. Because our goal is to

estimate β_1 , β_2 , and β_3 out of relatively unanticipated default events, we control for GDP per capita growth and unemployment growth, because a worsening of a country’s domestic economy may lead to a decline in credit and to default; for inflation, which is often associated with debt crises; and for exchange rate depreciation, which accounts for speculative attacks and other channels whereby a currency’s instability can lead to private and public crises.

To further enhance our ability to identify relatively unanticipated defaults, we include in our regressions a time-varying index of investors’ perceptions of default risk at $t - 1$. This index is computed by the International Country Risk Guide (ICRG) by combining several factors that make a country more prone to default and less attractive to foreign investors. To further probe our hypothesis, we also control in our regressions for proxies of sudden stops, defined as a year in which GDP growth is negative and the current account deficit is reduced by more than 5%, and banking crises.²⁴ More broadly, to avoid identifying our effects from outliers, throughout all of our analyses we perform a careful and thorough sensitivity analysis based on Belsley et al. (1980).²⁵

Finally, to further probe our results, we complement the pooled OLS regressions with non-parametric propensity score matching methods, which allow us to relax the assumption of linearity in the relationship between default and private credit when trying to isolate relatively unanticipated default events.²⁶ We report the results in Table AV in the Internet Appendix to save space.

Before presenting the estimation results, it is important to stress two issues. First, in our tests of Corollary 2i), we are not concerned that our measure of financial institutions may be endogenous to default. The creditor rights index is in fact remarkably persistent over time and it varies systematically in the cross section with the legal system transplanted by colonizers many centuries ago (La Porta et al. 1998, Djankov et al 2007). In fact, our regressions (e.g. Equation (20)) exploit the cross-country and not the time series variation of creditor rights.²⁷ Second, our test of Corollary 2ii) also exploits the cross-country as opposed to the time series variation of bondholdings. In fact, we find that our measure of bank bondholdings has very little time series variation within-country.²⁸

Table II reports the results from estimating various specifications of Equation (20). The dependent variable is the annual change in private credit as a percentage of GDP. The most basic specification including the default dummy (and imposing $\beta_2 = \beta_3 = 0$) is presented in column (1). Column (2) adds to the basic specification the interactive term of default with domestic bank

bondholdings. Column (3) adds to the basic specification the interactive term of default with creditor rights. Column (4) reports the results from the full specification with both interactive terms. Finally, column (5) includes in the full specification the interactive term of default with openness, as proxied by foreign liabilities. Standard errors are heteroskedasticity-consistent and clustered at the country level.

[Table II about here]

In our baseline regression of column (1), the coefficient on the default dummy is negative and significant, consistent with the prediction of Corollary 1 that sovereign default should be followed by a lower private credit flow. The coefficient on the default dummy in column (1) implies that after default private credit drops by 2.5% of GDP. These effects are large in economic terms.

The negative coefficient on the interaction term between default and bank debtholdings in columns (2), (4), and (5) is consistent with our prediction that default is more disruptive of private financing in countries where banks hold more public bonds. The coefficient is marginally statistically significant in columns (2) and (5). The negative coefficient on the interaction term between default and creditor rights in columns (3), (4), and (5) is consistent with our prediction that public default is more disruptive of private financing in countries with better institutions. Finally, the negative coefficient on the interaction term between default and openness in column (5), as proxied by private foreign liabilities, is consistent with our prediction that default is more disruptive of private credit in countries more open to capital inflows. The economic magnitude of these effects is large. A one standard deviation increase in banks' bondholdings in a defaulting country is associated with a larger decrease in private credit of 2.5% of GDP (from column 2). An increase by one in the creditor rights score in a defaulting country (for example, moving from a score of 1, as in Argentina, to a score of 2, as in Chile) is associated with a more severe reduction in private credit by 3.8% of GDP (column 3). A one standard deviation increase in foreign liabilities in a defaulting country is associated with a more severe reduction in private credit by 14.2% of GDP (column 5).

Other variables have the predicted sign. In particular, positive GDP growth is associated with private credit increases, positive unemployment growth with private credit decreases, and a sudden stop with a decrease in private credit. Furthermore, and consistent with Reinhart and Rogoff (2011) and Acharya et al. (2013), banking crises as defined by Caprio and Klingebiel (2001) are

also associated with a decrease in private credit in columns (1) and (3).²⁹

In sum, Table II shows that sovereign defaults are followed by a weakening of domestic credit markets. Although our data does not allow for strong causality claims, we note that these correlations cannot be easily accounted for by pre-existing economic conditions in the defaulting country. This is consistent with our mechanism: default reduces the value of banks' assets, thereby limiting their ability to intermediate resources, either domestic or foreign. In line with this observation, the data also support the predictions of Corollary 2 that the post-default decline in credit is stronger in countries where creditor rights are stronger, banks hold more public bonds, and foreign borrowing is larger.

One interesting implication of Table II is that institutions and bondholdings seem to explain not only the severity of post-default declines in credit across countries, but also whether these declines occur at all. Note that once the interactive terms are introduced into the regression, the coefficient on default turns from negative to positive, suggesting that default may actually increase private credit in countries where financial institutions are weak and banks hold few public bonds.³⁰ This prediction is actually intuitive from a theoretical standpoint, since defaults increase the total amount of resources available in a country: if the banking system is relatively unaffected by a default, it seems plausible that private credit should increase in its aftermath.

In Table AIV in the Internet Appendix we report results from estimating a version of Equation (20) with a different dependent variable, the % change in private credit. The results are qualitatively similar to those found in Table II and imply that a sovereign default is associated with a 7.6% decrease of private credit (from column 1); that a one standard deviation increase in banks' bondholdings in a defaulting country is associated with a larger decrease in private credit by 11.5% (from column 2); that an increase by one in the creditor rights score in a defaulting country is associated with a more severe reduction of private credit by 11.9% (column 3); and that a one standard deviation increase in foreign liabilities is associated with a more severe reduction of private credit by 63%. Although the quantitative effects are large, the statistical significance is somewhat reduced, perhaps reflecting the larger variability of the private credit variable when it is not scaled by GDP. Finally, in Table AV in the Internet Appendix we report results from our propensity score estimation with matching. Compared with country-year pairs matched by GDP per capita growth, unemployment growth, default risk, inflation, exchange rate depreciation, and occurrence

of banking crises, country-years in default experienced a more severe decrease of private credit by 2.9% of GDP; this decrease was more severe by 2.4% of GDP in countries with above-median bank bondholdings and more severe by 2.7% of GDP in countries with a creditor rights score of 2 or higher. Overall, the results in Table AIV and AV in the Internet Appendix complement and corroborate the results found in Table II that default is associated with a decrease in private credit, which is larger in countries with higher bank bondholdings and with higher creditor rights.

C. *Ex-Ante Tests*

We now test the ex-ante predictions of Corollary 3, that better financial institutions should allow countries to default less often. We first study the determinants of default by running the probit regression:

$$\Pr(\text{Public Default})_{i,t} = F\left(v_t + \beta_1 (\text{Creditor Rights})_{i,t-1} + \beta_2 (\text{Bank Debtholdings})_{i,t-1} + X'_{i,t-1}\gamma\right). \quad (21)$$

Our model predicts that $\beta_1 < 0$ and $\beta_2 < 0$. One shortcoming of the probit model is that it does not allow us to control for country effects, so we estimate Equation (21) by selecting a large number of controls. One concern in this regression is reverse causality: banks may choose to reduce their bondholdings when the probability of default is high. (This is not true in our model, though, where banks are the efficient bearers of default risk.) To reduce this and other endogeneity issues, we again focus on unanticipated defaults. To do so, we control for the lagged value of default risk and – in line with existing work (Kraay and Nehru (2006), Reinhart and Rogoff (2010)) – we also control for lagged GDP per capita growth, the amount of short-term debt as a proportion of GDP, banking crises, and foreign reserves as a percentage of GDP. We also control for the lagged change in foreign liabilities to GDP. A negative sign on this last coefficient is consistent with the complementarity between external private and public borrowing. Unless specified otherwise, our data sources are the WDI and IFS databases.

Table III reports results from estimating Equation (21). Column (1) shows a negative correlation between the probability of default and bank bondholdings. Column (2) shows a negative correlation between the probability of default and creditor rights. Column (3) shows a negative association between foreign capital inflows to the private sector and the probability of government default. The

economic magnitudes are large in all cases. A standard deviation decrease in bank bondholdings makes a sovereign default more likely by 15.7%. A standard deviation decrease in creditor rights makes a sovereign default more likely by 3.7%. A standard deviation decrease in the extent of private foreign capital inflows makes a sovereign default more likely by 31.8%. Control variables have the predicted sign and are statistically significant – in particular, banking crises are positively associated with the likelihood of sovereign default, and countries with larger amounts of short-term debt as a proportion of GDP are more likely to default, consistent with Reinhart and Rogoff’s (2010) observation that short-term debt bonanzas precede episodes of sovereign default.

[Table III about here]

Overall, the results displayed in Table III confirm that sovereign defaults and banking crises often occur together (Reinhart and Rogoff (2010)), and in addition they show that default risk is lower in countries where creditor rights are stronger, where banks hold more public bonds, and where private capital inflows are larger. Although our data cannot fully establish causality, it is consistent with our predictions of Corollary 3.³¹

IV. Concluding Remarks

Recent history highlights a close connection between public defaults and private financial markets. In this paper, we have developed a theoretical model that characterizes this connection, and we have provided empirical evidence that is in line with the model’s main predictions. The general lesson of our analysis is that the willingness of a government to repay its debts, and thus its ability to borrow in the first place, depends on the development of private financial markets. More developed financial markets translate into more severe consequences of public defaults, thereby providing governments with stronger incentives to repay. This effect is especially pronounced in open economies, where the financial sector can attract foreign capital. This mechanism gives rise to a type of complementarity: countries with strong financial institutions attract private sector borrowing and, as a consequence, facilitate public borrowing by disciplining the government.

The findings of this paper resonate well with recent empirical evidence on the effects of financial globalization (see Kose et al. (2006)), which stresses that the main benefits of successful financial

integration are catalytic and indirect. In other words, these benefits are not simply – or even primarily – the result of enhanced access to foreign financing, but are also the result of increased discipline on macroeconomic policies and on public governance more generally. Our model sheds light on these findings for the case of a specific government policy – the decision of whether or not to default on public debt – and finds that the “disciplining” effect of international financial markets occurs only in countries with good market institutions.

At a broader level, our findings point towards a general mechanism through which domestic markets and institutions may shape the impact of financial integration on a variety of public policies. Much in the same way as government defaults, policies like opportunistic devaluations or hyperinflations do not just affect the returns obtained by foreigners on their investments; they are also likely to have other macroeconomic consequences that inflict losses on some classes of domestic residents. Our analyses suggests that the magnitude of these losses, and hence governments’ incentives to undertake these policies in the first place, are likely to depend on the quality and development of domestic markets. In a nutshell, our analyses suggests that governments might be able to attain some commitment along these policy dimensions by strengthening domestic market institutions, thereby broadening the scope of complementarity between well-functioning private markets and appropriate government behavior.

Appendix A. Bondholdings

To see why, in our model, banks strictly want to hold government bonds, consider the portfolio decision they face at time $t = 0$. The government is expected to repay fully if $A_B = A^H > 1$ and to default fully otherwise. If a bank purchases an amount b_B of bonds and holds an amount $-d_{B0}$ of deposits at $t = 0$ paying an expected gross interest rate of r_0 , its expected consumption at $t = 2$ is equal to

$$p \cdot \left[\frac{(1 - \alpha) \cdot A^H \cdot r_{d1}^H}{r_{d1}^H - \alpha \cdot A^H} \cdot \left(\omega_{1B} + \frac{b_B}{p} + d_{0B} \cdot r_{d0}^H(1) - \frac{b}{p} \right) \right] + (1 - p) \cdot [\omega_{1B} + d_{0B} \cdot r_{d0}^L(0)], \quad (\text{A1})$$

where r_{d1}^H denotes the interest rate on deposits originated at $t = 1$ when $\pi = H$. The first term in Equation (A1) reflects that with probability p , productivity will be high and public debt is repaid. In this state, banks leverage their $t = 1$ wealth and borrow against their $t = 2$ modern-sector income to expand their investment. The second term in Equation (A1) reflects that with probability $(1 - p)$, productivity is low and the government defaults. Note that Equation (A1) makes explicit the fact that the ex-post rate of return on deposits, $r_{d0}^\pi(\cdot)$ for $\pi \in \{H, L\}$, is affected by the government's repayment decision. We initially restrict ourselves to the case in which $-d_{0B} \cdot r_{d0} \leq \alpha \cdot \omega_{1B}$: under this constraint, repayment by the bank to depositors is non-contingent and $r_{d0}^L(0) = r_{d0}^H(1) = r_0$. Since the maximum amount of bonds a bank can purchase is $\omega_0 - d_{0B}$, its optimal portfolio decision at $t = 0$ reduces to:

$$\begin{aligned} \max_{-d_{0B}} p \left[\frac{(1 - \alpha) \cdot A^H \cdot r_{d1}^H}{r_{d1}^H - \alpha \cdot A^H} \cdot \left(\omega_{1B} + \frac{\omega_0 - d_{0B}}{p} + d_{0B} \cdot r_{d0}^H(1) - \frac{b}{p} \right) \right] + (1 - p) \cdot [\omega_{1B} + d_{0B} \cdot r_{d0}^L(0)] \\ \text{s.t.} \quad -d_{0B} \leq \frac{\alpha \cdot \omega_{1B}}{r_0}. \end{aligned} \quad (\text{A2})$$

The objective in Equation (A2) implies that, as long as

$$r_0 \leq \frac{(1 - \alpha) \cdot A^H \cdot r_{d1}^H}{(1 - p) \cdot (r_{d1}^H - \alpha \cdot A^H) + p \cdot (1 - \alpha) \cdot A^H \cdot r_{d1}^H},$$

a bank sets $-d_{0B} = \alpha \cdot \omega_{1B}/r_0$, taking the maximum amount of deposits allowed by the constraint in order to buy bonds. The intuition is simple: at $t = 0$, the most valuable assets for banks are those that promise to deliver at $t = 1$ in the event that investment is productive. The government bond has exactly this property, since it only repays in equilibrium if productivity is high. Besides their traditional sector output, banks can also pledge the proceeds of bonds themselves in order to further increase their bondholdings. This additional borrowing, though, will *de facto* be repaid only if the government repays its debt: otherwise, banks have only their traditional sector output and can only repay $\alpha \cdot \omega_{1B}$. In a sense, then, whenever banks pledge the proceeds of public bonds and use that to expand their bondholdings, they are borrowing funds that will have to be repaid fully in the productive state (at an effective contractual rate of r_0/p) and they are investing these funds

in bonds that also pay only in that state (at a contractual rate of r_b/p). Hence, whenever $r_0 > 1$, banks are unwilling to pledge income beyond their traditional sector output and bondholdings are given by $\omega_0 + \alpha \cdot \omega_1/r_0$. If $r_0 = 1$, on the other hand, they are indifferent between expanding their bondholdings beyond $\omega_0 + \alpha \cdot \omega_1$ and not doing so: we assume that, in the event of such indifference, they expand their bondholdings as much as possible. The same assumption holds for savers throughout, since they are also indifferent between holding government bonds and not doing so if $r_0 = 1$. In a sense, then, we determine the weakest possible conditions under which government debt is sustainable in equilibrium.

In the case of the closed economy, equilibrium bondholdings will depend on whether α exceeds the threshold identified as α_0 in Equation (11). If $\alpha > \alpha_0$, then all of the economy's resources are allocated to banks at $t = 0$, and bondholdings will consequently be given by,

$$\begin{aligned} b_B &= \frac{\omega_0}{\beta} \\ b_S &= 0. \end{aligned} \tag{A3}$$

If instead $\alpha < \alpha_0$, $r_0 = 1$ and bondholdings by savers are undetermined. Assuming that savers buy an equal amount of private bonds, bondholdings will be given by,

$$\begin{aligned} b_B &= \frac{\omega_0 + \alpha \cdot \omega_{1B}}{1 - \alpha} \\ b_S &= \frac{\omega_0(1 - \alpha - \beta) - \beta \cdot \alpha \cdot \omega_{1B}}{(1 - \beta)(1 - \alpha)}. \end{aligned} \tag{A4}$$

In the case of the open economy, since the constraint imposed by α_0 is irrelevant and we assume throughout that $r_0 = 1$, bondholdings are simply given by

$$b_j = \frac{\omega_0 + \alpha \cdot \omega_{1j}}{1 - \alpha} \quad \text{for } j \in \{B, S\}. \tag{A5}$$

Appendix B. Government Repayment and Debt Sustainability

At $t = 1$, provided that $\pi = H$ and $r_{d1} = 1$, the government maximizes the following welfare function with respect to ρ^H :

$$[\beta \cdot W_B(\rho^H) + (1 - \beta) \cdot W_S(\rho^H)] + \frac{A^H - 1}{1 - \alpha \cdot A^H} \cdot \beta \cdot W_B(\rho^H).$$

The actual values of $W_j(\cdot)$ depends, of course, on equilibrium bondholdings. There are three cases to consider:

1. $\alpha \in (0, \alpha_0]$, where α_0 is as in Equation (11): in this case, banks pledge a fraction α of all their $t = 1$ revenues, including the proceeds from public bonds, and invest these in bonds at $t = 0$. Replacing these bondholdings in the welfare function, the government's first-order condition becomes

$$[\omega_0 - 1] + \frac{A^H - 1}{1 - \alpha \cdot A^H} \cdot \beta \cdot [\omega_0 + \alpha \cdot \omega_{1B} - 1] \geq 0.$$

2. $\alpha \geq \bar{\alpha}_0$, where $\bar{\alpha}_0 = \frac{\omega_0 \cdot (1-\beta)}{\beta \cdot \omega_{1B}} > \alpha_0$: in this case, banks can borrow all domestic funds and use them to purchase government bonds only by pledging their traditional sector income. In this case, given their bondholdings, the government's first-order condition becomes

$$[\omega_0 - 1] + \frac{A^H - 1}{1 - \alpha \cdot A^H} \cdot \beta \cdot \left[\frac{\omega_0}{\beta} - 1 \right] \geq 0.$$

3. $\alpha \in (\alpha_0, \bar{\alpha}_0)$: in this case, banks pledge some, but not all of their future proceeds from public bonds in order to acquire bonds at $t = 0$. This means that, unlike the previous cases, the marginal benefit of repayment is not constant for the government: whereas repayment of the first units of public debt (i.e., for $\rho^H \approx 0$) goes partly to the banks and partly to its creditors, repayment of the last units of public debt are appropriated fully by the banks (i.e., for $\rho^H \approx 1$). In this case, welfare as a function of ρ^H is given by

$$\left[\frac{(\omega_0 - 1)}{p} \cdot \rho^H + \omega_1 \right] + \frac{A^H - 1}{1 - \alpha \cdot A^H} \cdot \beta \cdot \left[\left(\frac{\omega_0}{\beta} - 1 \right) \frac{\rho^H}{p} + \omega_{1B} - \min \left\{ \alpha \left(\frac{\omega_0}{\beta \cdot p} \rho^H + \omega_{1B} \right), \frac{\omega_0(1-\beta)}{\beta \cdot p} - \frac{(1-p)}{p} \alpha \omega_{1B} \right\} \right],$$

where the last term $\min \{ \cdot, \cdot \}$ captures the fact that whether banks are able to repay their nominal debts in full or not depends on the government's decision to repay. Since this welfare function is convex in ρ^H , comparing its value under $\rho^H = 0$ and $\rho^H = 1$ yields the following necessary and sufficient condition for repayment:

$$\omega_0 - 1 + \frac{A^H - 1}{1 - \alpha \cdot A^H} \cdot \beta \cdot \left[\left(\frac{\omega_0}{\beta} - 1 \right) + p \cdot \omega_{1B} - \frac{\omega_0(1-\beta)}{\beta} + (1-p) \cdot \alpha \cdot \omega_{1B} - p \cdot \omega_{1B} \cdot (1-\alpha) \right] \geq 0,$$

which reduces to the same condition as in case 1.

Therefore, all three cases can be summarized in the condition that

$$[\omega_0 - 1] + \frac{A^H - 1}{1 - \alpha \cdot A^H} \cdot \beta \cdot \left[\min \left\{ \omega_0 + \alpha \cdot \omega_{1B}, \frac{\omega_0}{\beta} \right\} - 1 \right] \geq 0,$$

which explains Equation (14) in the main body of the paper. From the previous analysis, we can obtain

$$\alpha^{\min}(\beta) = \max \left\{ \frac{1 + (A^H - 1) \cdot \beta}{A^H + \left[\frac{A^H - 1}{1 - \omega_0} \right] \cdot \beta \cdot \omega_{1B}}, \frac{(1 - \beta) + A^H \cdot (\beta - \omega_0)}{A^H \cdot (1 - \omega_0)} \right\}.$$

Appendix C. Proof of Proposition 1

The first part of the proposition follows directly from the discussion in the main body of the text. It remains to be shown that there exist values of β for which $\alpha^{\min}(\beta) < \alpha^{\max}(\beta)$, so that the optimal level of public debt is sustainable in equilibrium when $A_B = A^H$. Since $\alpha^{\min}(0) = \alpha^{\max}(0) = 1/A^H$,

we proceed by analyzing the conditions under which

$$\left. \frac{\partial \alpha^{\min}(\beta)}{\partial \beta} \right|_{\beta=0} < \left. \frac{\partial \alpha^{\max}(\beta)}{\partial \beta} \right|_{\beta=0},$$

which would guarantee the sustainability of debt for low levels of β .

From Equation (14), we can obtain,

$$\alpha^{\min}(\beta) = \frac{1 + (A^H - 1) \cdot \beta}{A^H + \frac{(A^H - 1) \cdot \beta}{1 - \omega_0} \cdot \omega_{1B}}, \quad (\text{C1})$$

and

$$\left. \frac{\partial \alpha^{\min}(\beta)}{\partial \beta} \right|_{\beta=0} = \frac{(A^H - 1)}{(A^H)^2} \cdot \left[A^H - \frac{\omega_{1B}}{1 - \omega_0} \right]. \quad (\text{C2})$$

We assume throughout that $\left(A^H + \frac{\omega_{1B}}{\omega_{1S}} \right) \cdot (1 - \omega_0) < \omega_{1B}$, which in particular guarantees that Equation (C2) is negative. On the other hand, Equation (7) yields

$$\alpha^{\max}(\beta) = \frac{(1 - \beta) \cdot (\omega_0 - 1 + \omega_{1S} \cdot p)}{A^H \cdot (\omega_0 - 1 + p \cdot \omega_1) + (1 - p) \cdot \beta \cdot \omega_{1B}},$$

and

$$\left. \frac{\partial \alpha^{\max}(\beta)}{\partial \beta} \right|_{\beta=0} = \frac{1}{A^H} \cdot \left[-1 - \frac{A^H \cdot p \cdot (\omega_{1B} - \omega_{1S}) + (1 - p) \cdot \omega_{1B}}{A^H \cdot (\omega_0 - 1 + \omega_{1S} \cdot p)} \right].$$

Hence, a sufficient condition for debt to be sustainable for some combination (α, β) is that

$$A^H - 1 - \frac{\omega_{1B}}{1 - \omega_0} \cdot \frac{(A^H - 1)}{A^H} < -1 - \frac{A^H \cdot p \cdot (\omega_{1B} - \omega_{1S}) + (1 - p) \cdot \omega_{1B}}{A^H \cdot (\omega_0 - 1 + \omega_{1S} \cdot p)},$$

which reduces to

$$p > p^* = \frac{A^H \cdot (1 - \omega_0)}{\omega_{1S} \cdot (A^H - 1)} \cdot \left[\frac{\omega_{1B} - (1 - \omega_0) \cdot A^H}{\omega_{1B} - (1 - \omega_0) \cdot \left(A^H + \frac{\omega_{1B}}{\omega_{1S}} \right)} \right].$$

Appendix D. Proof of Proposition 2

From Equation (18) we obtain

$$\alpha_{open}^{\min}(\beta) = \frac{1 + (A_H - 1) \cdot \beta}{A_H - \left[\frac{A_H \cdot \alpha_{open}^{\min}(\beta) - 1}{1 - \omega_0} \right] \cdot \omega_1 + \left[\frac{A_H - 1}{1 - \omega_0} \right] \cdot \beta \cdot \omega_{1B}}, \quad (\text{D1})$$

which defines values of α above which public debt is sustainable in the open economy. Note that we have not fully solved for α in order to keep the expression simple. A comparison of Equations (C1) and (D1) reveals that, insofar as $\alpha < 1/A_H$, $\alpha_{open}^{\min}(\beta) < \alpha^{\min}(\beta)$.

Appendix E. Proof of Proposition 3

From Equation (18) we obtain

$$\alpha_{open}^{\min}(\beta, r_1^*) = \frac{r_1^* + (A_H - r_1^*) \cdot \beta}{A_H - \left[\frac{A_H \cdot \alpha_{open}^{\min}(\beta, r_1^*) - r_1^*}{1 - \omega_0} \right] \cdot \omega_1 + \left[\frac{A_H - r_1^*}{1 - \omega_0} \right] \cdot \beta \cdot \omega_{1B}}, \quad (\text{E1})$$

from which it can be verified that $\alpha_{open}^{\min}(\beta, r_1^*)$ is increasing in r_1^* . In particular, when $r_1^* \rightarrow 1$, $\alpha_{open}^{\min}(\beta, r_1^*) < \alpha^{\min}(\beta)$: this follows from comparing Equations (E1) and (C1) and noting that, in the closed economy, $r_{d1} \geq 1$. When $r_1^* \rightarrow A_H$, on the other hand, Equation (E1) implies that $\alpha_{open}^{\min}(\beta, r_1^*) \rightarrow 1$ so that it is necessarily higher than $\alpha^{\min}(\beta)$. Therefore, there exists a value $r^* \in (1, A_H)$ for which $\alpha_{open}^{\min}(\beta, r^*) = \alpha^{\min}(\beta)$.

Appendix F. Ex-ante Complementarity

This section discusses ex-ante complementarity between public and private borrowing, i.e., the notion that the supply of public debt makes it possible for the private sector to expand its borrowing and investment relative to the case in which public bonds are not available. In our model, this happens because public debt enables bankers to transfer their wealth to the state of nature in which investment is most productive, while at the same time the private sector cannot produce assets that perfectly substitute government bonds.

The main advantage of public bonds in our model is that their payoff is positively correlated with the state of domestic productivity and thus with the investment opportunity of domestic banks. To see this, consider an open economy with $r_0^* = r_1^* = 1$, and compare the total profits of bankers in our baseline equilibrium, i.e., the one in which the government sets $b = 1$ and repays only in the high-productivity state, with the profits of bankers in an alternative equilibrium in which the government sets $b = 1$ but repays in both states. In this last case, the public bond is riskless. Thus, it is equivalent in all respects to the foreign bond. In our setup, because of linearity, comparing welfare amounts to comparing output in both scenarios.

A comparison of the above equilibria shows that expected bank profits are greater in the case in which the payoffs of public bonds are state-contingent. This comparison is done by using Equation (A1) and computing (i) the profits of banks when public bonds deliver only in the high-productivity state and bondholdings are given by Equation (A5) with (ii) the profits that they would attain by investing only in riskless bonds. The difference between (i) and (ii) amounts to:

$$(1 - p) \cdot \frac{A^H - 1}{1 - \alpha \cdot A^H} \cdot [\omega_0 + \alpha \cdot \omega_{1B} - 1] > 0. \quad (\text{F1})$$

Equation (F1) says that contingent public bonds expand expected output and bank profits according to three components: (i) $(1 - p)$, which is the probability that the government defaults on its

debt; (ii) $\frac{A^H - 1}{1 - \alpha \cdot A^H}$, which captures the differential return to the bankers' net worth in the high-productivity state relative to the low-productivity one, and; (iii) $\omega_0 + \alpha \cdot \omega_{1B} - 1$, which captures the net resources that bankers are expected to receive from the government in terms of debt repayment. To see this, note that this last expression is the difference between (i) a fraction $(1 - \alpha)$ of the expected income from bondholdings, as captured by Equation (A5), and (ii) the expected taxes that each domestic resident has to pay to service the debt. Equation (F1) thus shows that public debt is beneficial for private borrowing because it is state-contingent in a way that enables banks to transfer their resources to the high-productivity state: if either $(1 - p) = 0$ or $(A_H - 1) = 0$, as the expression shows, this benefit disappears.

One may wonder whether this result is an artifact of our particular assumptions regarding (i) linearity of preferences and technology and (ii) the lack of other, privately produced, state-contingent assets in the economy. We now argue that, at least qualitatively, this is not the case.

With respect to linearity, consider the case in which bankers are risk averse. To simplify matters, we can assume that they care only about consumption at $t = 2$. We also assume that they are expected utility maximizers, with a utility function $u(\cdot)$, where $u'(\cdot) > 0$ and $u''(\cdot) < 0$. In this case, the expected utility of a banker in the equilibrium with only riskless bonds is given by

$$p \cdot u \left(\frac{(1 - \alpha) \cdot A^H}{1 - \alpha \cdot A^H} \cdot (\omega_0 + \omega_{1B} - 1) \right) + (1 - p) \cdot u(\omega_{1B} + \omega_0 - 1). \quad (\text{F2})$$

Equation (F2) has a very natural interpretation. In the case of riskless bonds, the wealth of banks at $t = 1$ is state invariant and equal to $\omega_{1B} + \omega_0 - 1$. In the high-productivity state, however, this wealth can be levered and invested to generate profits: this is captured by the first term above. In the low-productivity state, instead, investment does not generate any additional profits. Note that the bankers' profits are stochastic even when they hold only riskless bonds. The reason, of course, is that the bankers' wealth may be constant but productivity is not.

What would change if bankers had access to a state-contingent bond, which only paid off in the high-productivity state? Since we have not changed the technology relative to our benchmark economy, we already know that such an asset could be used by the bankers to expand expected borrowing and investment. The only question, though, is whether they would actually use it, i.e., whether risk averse bankers would be willing to hold risky public bonds. By doing so, they would raise expected consumption at the cost of concentrating more of it in the productive state of nature. To see this trade-off, note that – starting from a portfolio of purely riskless bonds – the marginal utility from holding a risky bond would be positive if and only if

$$u' \left(\frac{(1 - \alpha) \cdot A^H}{1 - \alpha \cdot A^H} \cdot (\omega_0 + \omega_{1B} - 1) \right) \cdot \left(\frac{(1 - \alpha) \cdot A^H}{1 - \alpha \cdot A^H} \right) \geq u'(\omega_{1B} + \omega_0 - 1), \quad (\text{F3})$$

where we have assumed that the individual banker takes the profile of taxation as given. Clearly, whether Equation (F3) holds or not depends on the risk aversion of bankers and on the return of investment in the high-productivity state. If risk aversion is sufficiently low and the return on

investment is sufficiently high, bankers will still demand some risky bonds, as their risk will be more than compensated by their effective return. In this case, our qualitative results still apply.

Finally, would anything change if private agents were able to provide state-contingent assets? Clearly, if the private sector could supply an unlimited amount of these assets, there would be no liquidity service for public debt to provide. Banks could always transfer their resources, and thus their investment, towards the productive state of nature independently of the amount of debt issued by the government. To illustrate this point, we can return to our baseline economy (i.e., with risk-neutral agents) and assume that both bankers and savers are able to issue and trade a pair of state-contingent assets, which deliver either in the high- or in the low-productivity state. Let us refer to these as the H - and L -security, depending on the state of delivery, and let us assume that their price is actuarially fair. In such a scenario, bankers at $t = 0$ will want to sell the maximum possible number of L securities: such a sale would allow each one of them to raise $(1 - p) \cdot \alpha \cdot \omega_{1B}$ in revenues. Given these revenues and their initial endowments, bankers would then spend a total of $\beta \cdot [\omega_0 + (1 - p) \cdot \alpha \cdot \omega_{1B}]$ to buy the H -securities issued by savers. But if the pledgeable income of savers in the H -state $-\beta \cdot \alpha \cdot \omega_{1s}$ is low, then savers might be unable to issue enough securities to satisfy the demand of bankers at the stipulated price. Note that this is especially likely when α is low, i.e., the private sector's ability to produce these securities is limited by the low quality of financial institutions. In this case, the government can help raise expected intermediation and output by issuing its own H -securities in the form of risky debt.

Appendix G. Theoretical robustness

Since our main results are derived in a stylized setting, it is natural to explore some extensions and alternative specifications. Here we discuss how these results are affected when some of our main assumptions are relaxed.

Non-discriminatory enforcement, taxation, and bailouts. A central assumption behind our analysis is that both government repayment and taxation are fully non-discriminatory. Non-discrimination in repayment seems to fare well with empirical evidence: Sturzenegger and Zettelmeyer (2005), for example, study a large sample of recent defaults and find no evidence of systematic discrimination in the treatment of domestic and foreign creditors. But non-discrimination can also be theoretically justified by the fact that, in recent years, most sovereign borrowing has been undertaken through decentralized bond markets and thus has been subject to active trading in secondary markets. Broner et al. (2010) show theoretically that, in this case, it may be difficult for a government to discriminate among different types of bondholders. To see the logic of this argument, we add two features to our baseline model of the open economy. First, we obviously assume that public bonds can be traded in secondary markets at any point before they are redeemed: these markets are competitive, and they are not subject to interference by the government. Second, we assume that the government makes its enforcement and taxation decisions at $t = 1$, before asset payments and taxation take place, so that there is a lag between the adoption

of an enforcement/taxation policy and its execution.

Suppose that, under these assumptions, the government tries to enforce payments in a discriminatory fashion. In particular, imagine that it decides to repay bonds that are in the hands of domestic residents while defaulting on bonds that are in the hands of foreigners. In this case, foreigners that hold domestic bonds have an incentive to sell them in the secondary market at any positive price, since they will not collect anything from the government at the time of repayment: thus, the supply of bonds in the secondary market is inelastic and equals $1 - \omega_0$. Who demands these bonds? Clearly, domestic residents do; since they expect to be fully repaid by the government, they are willing to pay up to $\frac{1}{p}$ per bond. If the government announces a discriminatory enforcement policy, the only possible equilibrium is one in which – before asset payments are made – foreigners sell all of their bonds to domestic residents in the secondary market at a unit price of $\frac{1}{p}$ (this requires that the domestic endowment be high enough, i.e. $\omega_1 \geq \frac{1 - \omega_0}{p + \alpha}$). In this case, foreigners are *de facto* repaid by domestic residents through the secondary market, and the government is thus unable to discriminate. The only way in which it can avoid making payments to foreigners is to default on all bonds, as we have assumed that it does in the main body of the paper.

By the same logic, secondary markets also limit the government’s ability to bailout banks that are hurt by a public default. To see this, consider that – at the time of deciding its enforcement and taxation policy – the government defaults on all public bonds. It also decides to tax consumers in order to bailout the banking system, paying a subsidy of $\frac{1}{p}$ per defaulted bond as a compensation for banks’ losses. But this policy amounts to discriminatory enforcement, since banks are ultimately being repaid in excess of other bondholders. Once again, there are gains from trading bonds in the secondary markets. Before taxation takes place, all bondholders except banks have an incentive to sell their bonds in the secondary market at any positive price. Banks, in turn, are willing to pay up to $\frac{1}{p}$ per bond in order to collect the government compensation. In this manner, all bondholders other than banks are *de facto* repaid by banks through the secondary market, and the government is thus unable to discriminate through taxation.

Risk aversion. We have simplified the model by assuming risk neutrality for all agents. Because of this assumption, bankers strictly prefer to hold government bonds rather than foreign bonds or deposits, while savers are indifferent among all existing assets. We have assumed throughout that, whenever indifferent, domestic residents hold as many bonds as they can purchase. Although the introduction of risk aversion would complicate the exposition along some dimensions, there is also a sense in which it could make our results cleaner. In particular, risk aversion would decrease the bondholdings of savers relative to those of bankers, who would still value the positive correlation between the bond’s payoff and the productivity of investment.

Role of public investment. We assumed exogenously that the government always wants to undertake public investment, without specifying the role that such investment plays. All of our results would hold if we assumed that the public investment served some productive purpose. It could be thought, for example, that it is the public investment at $t = 0$ that gives rise to the investment opportunities in the modern sector at $t = 1$. In this case, our analysis regarding the

government's incentives to repay its debt would still hold up: regardless of the reason for which the government borrows and invests, such incentives depend only on the size and distribution of domestic bondholdings. At the same time, our analysis regarding domestic demand for public bonds is also independent of the specific role of public investment. The only thing that would change relative to our current analysis is that it would need to be verified that it is optimal for the government to invest and develop the modern sector. Formally, this requires that

$$p \cdot (A_H - 1) \cdot I(\omega_0 + \omega_1 - 1) > 1.$$

REFERENCES

- Acemoglu, Daron, Simon Johnson, and James A. Robinson, 2001, The colonial origins of comparative development: an empirical investigation, *American Economic Review* 91, 1369-1401.
- Acharya, Viral V., Itamar Drechsler, and Philipp Schnabl, 2013, A Pyrrhic victory? Bank bailouts and sovereign credit risk, mimeo, NYU Stern.
- Ağca, Şenay, and Oya Celasun, 2012, Sovereign debt and corporate borrowing costs in emerging markets, *Journal of International Economics* 88, 198-208.
- Aoki, Kosuke, Gianluca Benigno, and Nobuhiro Kiyotaki, 2009, Adjusting to capital account liberalization, mimeo, Princeton.
- Arellano, Cristina, 2008, Default risk and income fluctuations in emerging economies, *American Economic Review* 98, 690-712.
- Arteta, Carlos, and Galina Hale, 2008, Sovereign debt crises and credit to the private sector, *Journal of International Economics* 74, 53-69.
- Basu, Suman, 2009, Sovereign debt and domestic economic fragility, mimeo, MIT.
- Beck, Thorsten, Asli Demirgüç-Kunt and Ross Levine, 2000, A new database on financial development and structure, *World Bank Economic Review* 14, 597-605.
- Bekaert, Geert, Campbell R. Harvey, and Christian Lundblad, 2005, Does financial liberalization spur growth?, *Journal of Financial Economics* 77, 3-55.
- Belsley, David A., Edwin Kuh and Roy E. Welsch, 1980, *Regression diagnostics: Identifying influential data and sources of collinearity* (New York: Wiley).
- Bolton, Patrick, and Olivier Jeanne, 2011, Sovereign default and bank fragility in financially integrated economies, *IMF Economic Review* 59, 162-194.
- Borensztein, Eduardo, and Ugo Panizza, 2009, The costs of sovereign default, *IMF Staff Papers, Palgrave Macmillan* 56, 683-741.

- Broner, Fernando, Alberto Martin and Jaume Ventura, 2010, Sovereign risk and secondary markets, *American Economic Review* 100, 1523-1555.
- Broner, Fernando A., and Jaume Ventura, 2011, Globalization and risk sharing, *Review of Economic Studies* 78, 49-82.
- Brutti, Filippo, 2011, Sovereign defaults and liquidity crises, *Journal of International Economics* 84, 65-72.
- Caballero, Ricardo J., and Arvind Krishnamurthy, 2001, International and domestic collateral constraints in a model of emerging market crises, *Journal of Monetary Economics* 48, 513-548.
- Calvo, Guillermo A., Alejandro Izquierdo and Luis-Fernando Mejia, 2003, On the empirics of sudden stops: The relevance of balance-sheet effects, NBER Working Paper 10520.
- Caprio, Gerard, Jr., and Daniela Klingebiel, 2001, Bank insolvencies: cross-country experience, Unpublished Working Paper 1620, World Bank, Washington, DC.
- Caprio, Gerard, Jr., Daniela Klingebiel, Luc Laeven, and Guillermo Noguera, 2005, "Appendix: banking crisis database," in Patrick Honohan and Luc Laeven (eds.), *Systemic Financial Crises: Containment and Resolution* (Cambridge, UK: Cambridge University Press).
- Diamond, Douglas W., 1984, Financial intermediation and delegated monitoring, *Review of Economic Studies* 51, 393-414.
- Djankov, Simeon, Caralee McLiesh, and Andrei Shleifer, 2007, Private credit in 129 countries, *Journal of Financial Economics* 84, 299-329.
- Eaton, Jonathan and Raquel Fernandez, 1995, Sovereign debt, in G. Grossman and K. Rogoff, eds.: *Handbook of International Economics* III (North-Holland: Elsevier).
- Eaton, Jonathan and Mark Gersovitz, 1981, Debt with potential repudiation: Theoretical and empirical analysis, *Review of Economic Studies* 48, 284-309.
- Gertler, Mark, and Nobuhiro Kiyotaki, 2010, Financial Intermediation and Credit Policy in Business Cycle Analysis, mimeo, NYU.

- Gertler, Mark, and Kenneth S. Rogoff, 1990, North-South lending and endogenous domestic capital market inefficiencies, *Journal of Monetary Economics* 26, 245-266.
- Guembel, Alexander, and Oren Sussman, 2009, Sovereign debt without default penalties, *Review of Economic Studies* 76, 1297-3120.
- Guidotti, Pablo Emilio, Federico Sturzenegger, and Agustin Villar, 2004, On the consequences of sudden stops, *Economia* 4, 171-214.
- Holmström, Bengt, and Jean Tirole, 1993, Market liquidity and performance monitoring, *Journal of Political Economy* 101, 678-709.
- Huber, Peter J., 1967, The behavior of maximum likelihood estimates under non-standard conditions. In: Proceedings of the Fifth Berkeley Symposium on Mathematical Statistics and Probability, Vol. 1, University of California Press.
- IMF, 2002, Sovereign debt restructurings and the domestic economy experience in four recent cases.
- Kose, M. Ayhan, Eswar Prasad, Kenneth Rogoff and Shang-Jin Wei, 2006, Financial globalization: A reappraisal, working paper, IMF.
- Kraay, Aart, and Vikram Nehru, 2006, When is external debt sustainable? *The World Bank Economic Review* 20, 341-366.
- Kumhof, Michael, and Evan Tanner, 2008, Government debt: A key role in financial intermediation, in Reinhart, C., C. Végh, and A. Velasco, eds.: *Money, Crises and Transition, Essays in Honor of Guillermo A. Calvo*.
- Lane, Philip R., and Gian Maria Milesi-Ferretti, 2007, The external wealth of nations mark II: Revised and extended estimates of foreign assets and liabilities, 1970–2004, *Journal of International Economics* 73, 223-250.
- La Porta, Rafael, Florencio Lopez-de-Silanes, and Andrei Shleifer, 2008, The economic consequences of legal origins, *Journal of Economic Literature* 46, 285-332.
- La Porta, Rafael, Florencio Lopez-de-Silanes, Andrei Shleifer, and Robert W. Vishny, 1998. Law and finance. *Journal of Political Economy* 101, 678-709.

- Matsuyama, Kiminori, 2004, Financial market globalization, symmetry-breaking, and endogenous inequality of nations, *Econometrica* 72, 853-884.
- O'Brien, Yueh-Yun C., 2007, Reserve requirement systems in OECD countries, Finance and Economics Discussion Series (Washington, DC: Division of Research & Statistics and Monetary Affairs, Federal Reserve Board).
- Reinhart, Carmen M., and Kenneth S. Rogoff, 2010, *This time is different: A panoramic view of eight centuries of financial crises* (Princeton, NJ: Princeton University Press).
- Reinhart, Carmen M., and Kenneth S. Rogoff, 2011, From financial crash to debt crisis, *American Economic Review* 101, 1676-1706.
- Reinhart, Carmen M., Kenneth S. Rogoff, and Miguel A. Savastano, 2003, Debt intolerance, *Brookings Papers on Economic Activity* 1, 1-74.
- Sandleris, Guido, 2009, Sovereign defaults, domestic credit market institutions and credit to the private sector, UTDT mimeo.
- Sturzenegger, Federico, and Jeromin Zettelmeyer, 2006, *Debt defaults and lessons from a decade of crises* (Cambridge, MA: MIT Press).
- Sturzenegger, Federico, and Jeromin Zettelmeyer, 2008, Haircuts: Estimating investor losses in sovereign debt restructurings, 1998-2005, *Journal of International Money and Finance* 27, 780-805.
- White, Halbert S., 1980, A heteroskedasticity-consistent covariance matrix estimator and a direct test for heteroskedasticity, *Econometrica* 48, 817-838.

Notes

¹Of course, the EFSF was not created just to support troubled government finances. Its other goal was to enable private sector bailouts, allowing some countries (e.g., Ireland) to support their banking sectors, hurt by the bursting of real estate bubbles.

²In Section G of the Appendix we have a formal discussion of how the presence of secondary markets where public bonds are traded might limit the government's ability to treat domestic banks and foreign bondholders in a discriminatory fashion. Of course, our mechanism does not require that discrimination be impossible in reality, only that it be limited (see Section I.D).

³Borensztein and Panizza (2009) show that public defaults are associated with banking crises; Brutti (2011) shows that after default more financially dependent sectors tend to grow relatively less; Arteta and Hale (2008) use firm-level data to show that syndicated lending by foreign banks to domestic firms declines after default; Ağca and Celasun (2012) also use firm-level data to show the corporate borrowing costs increase after default. Reinhart and Rogoff (2011) document the co-occurrence of private and public financial crises. To the best of our knowledge, we are the first to look at the impact of default on aggregate measures of financial intermediation and to study how such effect depends on a country's financial institutions and banks' bondholdings.

⁴Indeed, the ability of governments to directly intervene in private contracts seems more limited than their ability to default. For instance, during the 2002 default the Argentine government tried to interfere with private contracts by forcing the "pesification" (at non-market exchange rates) of all dollar-denominated private sector assets and liabilities. Many creditors, however, took legal action against the government, which was forced to "redollarize" the assets (Sturzenegger and Zettelmeyer (2006)). Of course, in particularly severe crises the government might be tempted to alter domestic institutions, weakening this pecking order.

⁵Non-discrimination in repayment seems to fare well with empirical evidence: Sturzenegger and Zettelmeyer (2008), for example, study a large sample of recent defaults and find no evidence of systematic discrimination in the treatment of domestic and foreign creditors.

⁶See Section A in the Appendix for a more detailed derivation of domestic bondholdings. Throughout, we assume that whenever domestic residents are indifferent between investing in government bonds and not doing so, they invest all of their available resources in government bonds.

In a sense, then, we determine the weakest possible conditions under which government debt is sustainable in equilibrium.

⁷As is usually the case in this class of economies, there is also a pessimistic equilibrium in which the government is expected to fully default on its debt regardless of realized productivity at $t = 1$. In such an equilibrium, no bonds are issued because there is no demand for them. Consequently, the government does not make any decisions regarding repayment on the equilibrium path, beliefs are not proven wrong, and they are therefore consistent with equilibrium.

⁸In order for lump-sum taxation to be feasible, we assume throughout that $\omega_0 + \omega_{1S} > 1/p$.

⁹The Appendix also considers the case where $\alpha > \alpha_0$ and $b_B = \omega_0/\beta$.

¹⁰In line with the literature on financial frictions and capital flows, we capture the quality of financial institutions as the share of a debtor's resources that can be seized by creditors in the event of a default. In this formalization, better institutions enable greater leverage. This approach neglects other advantages of sounder financial systems, such as the availability of higher quality assets. Our modeling choice has the advantage of having a tight empirical counterpart in the 'creditor rights' score that we use in the empirical analysis.

¹¹We assume that the enforcement parameter α applies to all investors. Little would change if, in line with Caballero and Krishnamurthy (2001), banks could commit to repay more to domestic than to foreign investors. For a capital-importing country, this case would represent an intermediate outcome between the closed economy analysis of the previous section (which is equivalent to assuming that $\alpha = 0$ for foreign investors) and the analysis of this section.

¹²We want to assess the effects of liberalization when the international interest rate is higher than the one prevailing at Home under autarky. In our model, that cannot happen at $t = 0$ because the government sells bonds to domestic residents and to foreigners in a unified market.

¹³This result differs from existing international finance models in which capital flows to the public and private sectors are substitutes. In models with full commitment and complete markets, substitutability stems from Ricardian equivalence. In models of sovereign risk, the government decides whether to enforce all of the country's external debt, so that substitutability arises because such an enforcement decision depends on the total amount of payments.

¹⁴In our model, bonds expand the asset span because they provide a profile of payoffs that private assets don't. In Section F of the Appendix, we show that this result is robust to: (i) risk aversion on

behalf of banks, and (ii) the ability of the private sector to issue contingent assets, conditional on this probability being limited by pledgeability constraints. It is important to note that, although this direction of complementarity certainly requires public bonds to be valuable for private markets, it does not hinge on the specific reason that makes them so.

¹⁵See Equation (E1) in the Appendix.

¹⁶Note that Equation (19) must hold in equilibrium, for if $b_B < 1$ public debt is not sustainable ex-ante.

¹⁷Our theory has also predictions for the impact of default on investment that mirror the ones for private credit. Here we focus only on the latter because it is hard to identify the relevant finance “modern sector” in our our aggregate data. Using industry level data, Brutti (2011) finds that industries that are more financially dependent grow less in defaulting countries. See also Borensztein and Panizza (2009) for a similar analysis.

¹⁸This is the most appropriate measure to study the impact of public default on financial intermediation and to check if such impact is consistent with our predictions. It is beyond the scope of our paper to assess the desirability of financial intermediation. We, however, note that for public defaults to be socially costly, we do not require the level of intermediation to be socially efficient – only that the collapse in financial intermediation during a sovereign crisis is not desirable. This seems quite realistic, particularly given the fact that the emerging economies in our sample have low levels of private credit over GDP.

¹⁹As with most previous studies, we focus on whether a default occurs and not on monetary measures of creditors’ recovery such as the loss given default, for two main reasons. First, estimates of creditors’ losses given defaults (“haircuts”) are heavily dependent on the assumptions one makes about counterfactuals (e.g., Sturzenegger and Zettelmeyer (2006)). Second, it is widely accepted that sovereign defaults are very large and disruptive events. Moody’s (2007) estimates the average recovery rate on sovereign bonds to be 55% on an issuer-weighted basis and 29% on a volume-weighted basis. Sturzenegger and Zettelmeyer (2008) find that even under the most conservative assumptions, recovery rates range from a minimum of 13% to a maximum of 90% of the bonds’ par value.

²⁰Other potential proxies for institutions, such as for example the colonial origins of Acemoglu et al. (2001), are only available for a small subset of the countries in our sample.

²¹In the real world, the presence of capital adequacy ratios can mute the effect of stronger investor rights on leverage and thus bank assets. Because in our model leverage monotonically increases in α , tightening capital adequacy ratios would be akin (from an ex-ante standpoint) to capping the value of α .

²²Table AII in the Internet Appendix shows that the correlation is statistically significant when looking at pooled OLS, and also after controlling for country and time dummies. In particular, an increase by one in the creditor rights score is associated with a decrease in bank bondholdings by about two percentage points.

²³As in all cross-country empirical studies, especially those involving emerging economies, data availability issues affect sample size. We discuss these issues in the internet data appendix.

²⁴Controlling for pre-default banking crises also helps us distinguish our mechanism from the related but alternative “bailout channel” (Acharya, Drechsler, and Schnabl (2013)): if the government is committed to bailing out the banking sector in the event of distress, a weakening of the sector might increase public liabilities enough to trigger a government default.

²⁵Specifically, we check for the presence of influential observations by computing the DFbetas from each regression in Tables 2 and 3 (c.f., Belsley et al. (1980, p. 28)). DFbetas measure, for each observation, how much a coefficient would change if that observation were dropped from the data. Consistent with Belsley et al. (1980), we define an observation as influential if its $|\text{DFbeta}| > 1$. We present the results obtained by excluding such observation. After each regression, we list the observations (if any) dropped according to this criterion.

²⁶Propensity score estimation involves comparing changes in private credit for country-year pairs that are matched along a set of important (time-varying) country characteristics that potentially affect a country’s propensity to default, and that only differ in whether a default actually occurred or not.

²⁷In the sample used in Table II there is only one instance of institutional reform during default years (Indonesia 1998, in which the creditor rights score declined by one unit). More specifically, the results of Table 2 hold also if a country’s creditor rights score at $t - 1$ is replaced by its time average. Similar considerations apply with respect to the regressions of Table III on the probability of default.

²⁸In particular, we check our data to see if there are cases of countries in which banks sharply

increase their bondholdings during a period of sovereign default and debt crises, and we exclude country-year observations in which private credit and bondholdings change by more than 100%. This procedure eliminates the observations of Algeria 1992 and 1993 when private credit declined by 111% and bondholdings increased from 2.9% to 56.9% of banks' assets.

²⁹In Table II we find one influential observations in column (2), namely Panama in 1997, and we present the results without this observation. Results are also robust to performing appropriate versions of weighted least squares.

³⁰The coefficients in column (3) suggest that the effect of default on private credit is zero or slightly positive for countries having a creditor rights score of 0 or 1 and negative for countries having a creditor rights score of 2, 3, or 4, confirming with formal regression analysis the pattern already evident from the raw data in Figure 7.

³¹In particular, the fact that the probability of default decreases with banks' bondholdings is hard to reconcile with a story in which banking crises cause defaults but not the other way around. This is because the expectations of a bank run and thus of the ensuing public default would presumably become self-fulfilling if banks held many government bonds, generating the opposite sign to that found in Table III.

t = 0	t = 1	t = 2
ω_0 realized	A_B becomes known ω_1 realized	Output realized
	Asset payments made	Asset payments made
	GOVERNMENT REPAYMENT / TAXATION	
Asset markets open	Asset markets open	
Public investment	Private investment	

Figure 1. Timeline.

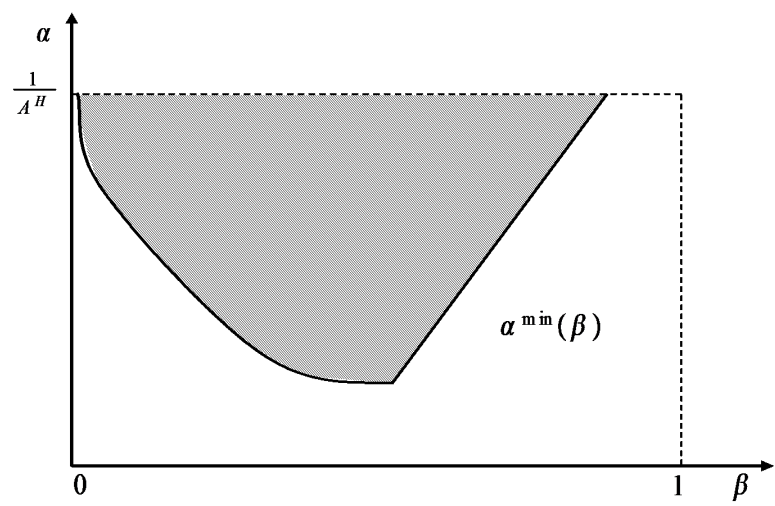

Figure 2. Debt sustainability in the closed economy - I.

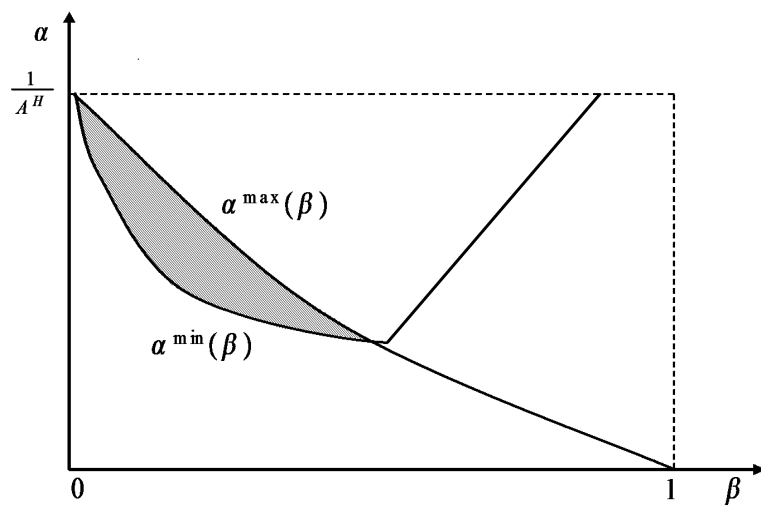

Figure 3. Debt sustainability in the closed economy - II.

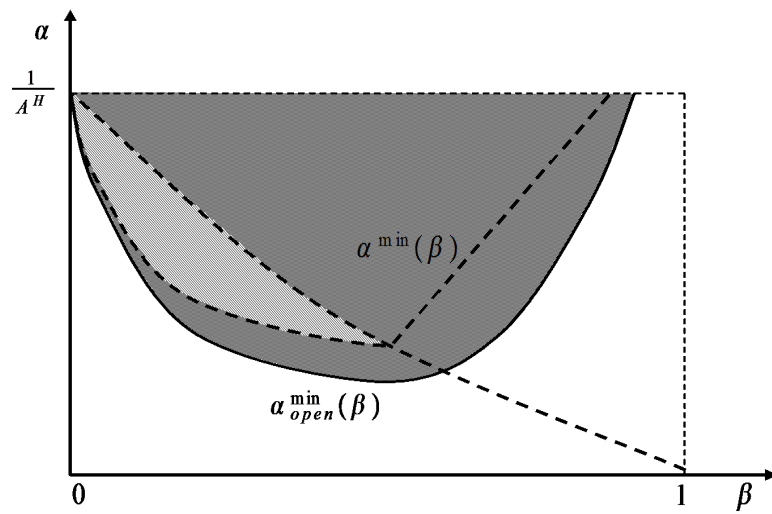

Figure 4. Debt sustainability in the open economy: capital importers.

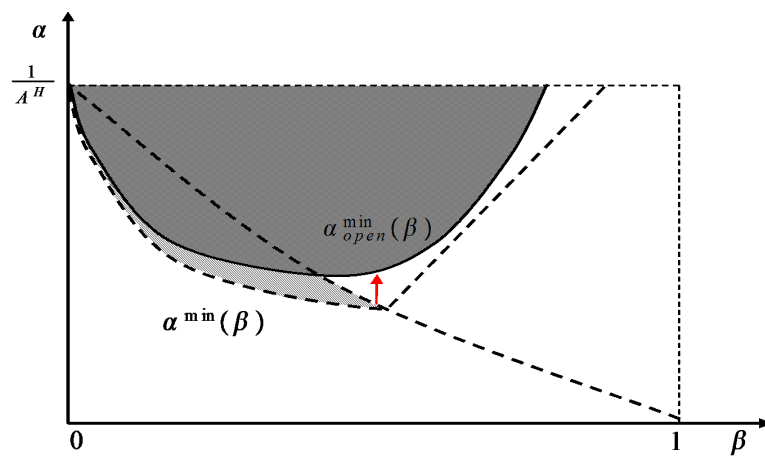

Figure 5. Debt sustainability in the open economy: capital exporters.

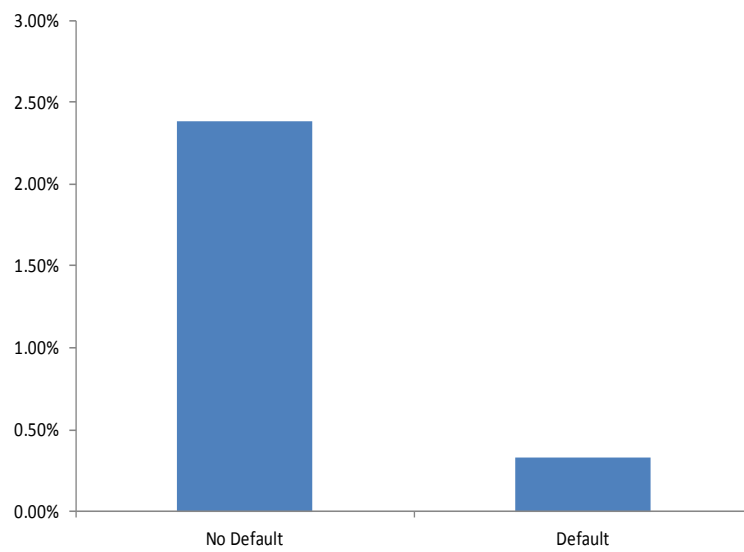

Figure 6. Private credit flows.

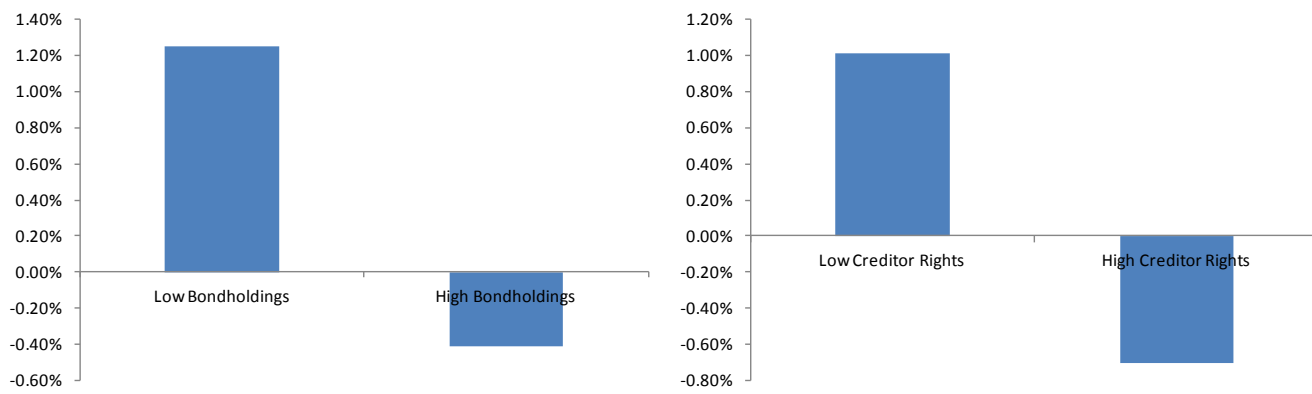

Figure 7. Private credit flows following default.

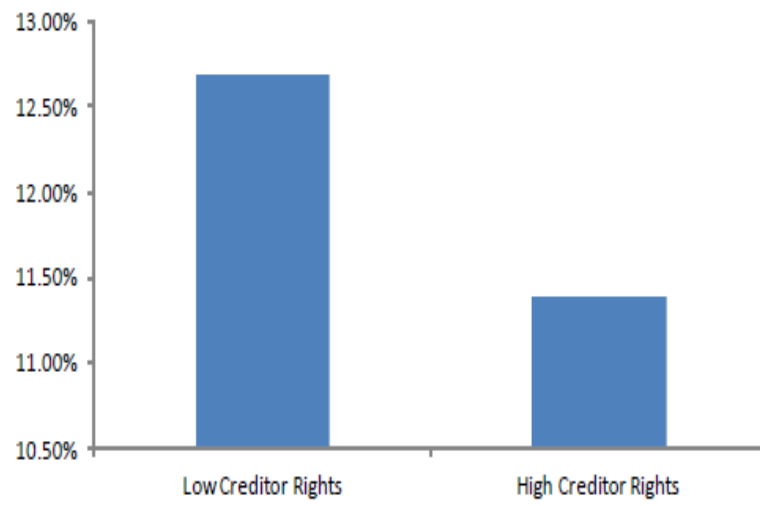

Figure 8. Bank bondholdings and creditor rights.

Table I – Sovereign Default Episodes and Banking Crises

The table reports episodes of sovereign defaults over 1980-2005, following the definition of sovereign default by Standard & Poor's. For each default episode, defined as an uninterrupted sequence of years in default by a country, the table reports whether a banking crisis in the same country had started or was ongoing in any of the three years before the beginning of the default episode, or whether it started subsequent to it.

Country	Sovereign Defaults	Banking Crisis	
		Started or ongoing in any of 3 years prior?	Started concurrently or subsequently?
Albania	1991-1995	No	Yes (1992)
Algeria	1991-1996	Yes (1990)	No
Angola	1985-2004	No	Yes (1991)
Antigua	1996-2004	No	No
Argentina	1982-1993, 2001-2004	Yes (1981), No	No, Yes (2001)
Bolivia	1980-1984, 1986-1997	No, No	No, Yes (1986)
Bosnia and Herzegovina	1992-1997	No	Yes (1992)
Brazil	1983-1994	No	Yes (1994)
Bulgaria	1990-1994	No	Yes (1996)
Burkina Faso	1983-1996	No	Yes (1988)
Cameroon	1985-2003	No	Yes (1987)
Cape Verde	1981-1996	No	Yes (1993)
Central African Republic	1981, 1983-2004	Yes (1980), Yes (1981)	No, No
Chile	1983-1990	Yes (1981)	No
Congo	1983-2004	No	Yes (1992)
Congo, Dem Rep.	1980-2004	No	Yes (1980)
Costa Rica	1981, 1983-1989	No, No	No, Yes (1994)
Cote d'Ivoire	1983-1998, 2000-2004	No, No	Yes (1988), No
Cuba	1982-2004	No	No
Dominica	2003-2004	No	No
Dominican Republic	1982-1994	No	No
Ecuador	1982-1995, 1999-2000	Yes (1980), Yes (1998)	No, No
Ethiopia	1991-1999	No	Yes (1994)
Gabon	1986-1994, 1999-2004	No, Yes (1997)	Yes (1995), No
Gambia	1986-1990	Yes (1985)	No
Ghana	1987	Yes (1986)	No
Guatemala	1989	No	Yes (1990)
Guinea	1986-1988, 1991-1998	Yes (1985), No	No, Yes (1993)
Guinea Bissau	1983-1996	No	Yes (1995)
Guyana	1982-2004	No	No
Haiti	1982-1994	No	No
Honduras	1981-2004	No	No
Indonesia	1998-2000, 2002	Yes (1997), Yes (2001)	No, No
Iran	1981-1995	No	No
Iraq	1987-2004	No	No
Jamaica	1981-1985, 1987-1993	No, No	No, Yes (1994)
Jordan	1989-1993	No	Yes (1989)
Kenya	1994-2004	Yes (1993)	No
Korea, Dem. Rep.	1980-2004	No	No
Liberia	1987-2004	No	Yes (1991)
Macedonia	1992-1997	No	Yes (1993)
Madagascar	1981-2002	No	Yes (1988)
Malawi	1982, 1988	No, No	No, No
Mauritania	1992-1996	Yes (1991)	No
Mexico	1982-1990	Yes (1981)	No
Moldova	1998, 2002	No, No	No, No
Morocco	1983, 1986-1989	Yes (1980), No	No, No
Mozambique	1980, 1983-2002	No, No	No, Yes (1987)
Myanmar	1997-2004	Yes (1996)	No
Nicaragua	1980-2004	No	Yes (late 1980s)
Niger	1983-1991	No	Yes (1983)
Nigeria	1982-1992, 2002	No, No	Yes (1991), No
Pakistan	1998-1999	No	No
Panama	1983-1996	No	Yes (1988)
Paraguay	1986-1992, 2003-2004	No, Yes (2001)	Yes (1995), No
Peru	1984-1997	Yes (1983)	No
Philippines	1983-1992	Yes (1981)	No
Poland	1981-1994	No	No
Romania	1981-1983, 1986	No, No	No, Yes (1990s)
Russia	1991-2000	No	No
Sao Tome and Principe	1987-1994	Yes (1980s)	No
Senegal	1981-1985, 1990, 1992-1996	No, Yes (1989), Yes (1991)	Yes (1988), No, No
Serbia and Montenegro	1992-2004	No	No
Seychelles	2000-2002	No	No
Sierra Leone	1983-1984, 1986-1995	No, No	No, Yes (1990)
Slovenia	1992-1996	No	Yes (1992)
South Africa	1985-1987, 1989, 1993	No, No, No	No, Yes (1989), No
Sudan	1980-2004	No	No
Tanzania	1984-2004	No	Yes (late 1980s)
Togo	1980, 1982-1984, 1988, 1991-1997	No, No, No, No	No, No, No, Yes (1993)
Trinidad and Tobago	1988-1989	Yes (1987)	No
Turkey	1982	No	Yes (1982)
Uganda	1980-1993	No	Yes (1994)
Ukraine	1998-2000	No	Yes (1998)
Uruguay	1983-1985, 1987	Yes (1981), Yes (1984)	No, No
Venezuela	1983-1988, 1990, 1995-1997	Yes (early 1980s), No, Yes (1994)	No, Yes (1993), No
Vietnam	1985-1998	No	Yes (1997)
Yemen	1985-2001	No	Yes (1996)
Yugoslavia	1983-1992	No	No
Zambia	1983-1994	No	Yes (1995)
Zimbabwe	1980, 2000-2004	No, Yes (late 1990s)	No, No
No Default Episodes	110	30	44

Table II – Where Is Default More Costly?

The table presents panel regressions for 46 countries over the 1980-2005 period. The dependent variable private credit flows to GDP is computed as private credit to GDP in year t minus private credit to GDP in year $t-1$. Sovereign default is a binary variable that equals 1 if the sovereign is in default in year $t-1$, 0 otherwise. Creditor rights is a discrete index ranging from 0 to 4 aggregating creditor rights, following La Porta et al. (1998) and Djankov et al. (2007). Openness is computed as private liabilities over GDP. Sudden stop is a dummy that equals 1 if in the previous year the country has negative GDP per capita growth and its current account balance increases by more than 5%. Standard errors (in parentheses below the coefficient estimates) are adjusted for heteroskedasticity using the Huber (1967) and White (1980) correction, as well as for clustering at the country level using the Huber (1967) correction. *** indicates significance at the 1% level; ** indicates significance at the 5% level; * indicates significance at the 10% level.

	Private Credit Flows to GDP				
	(1)	(2)	(3)	(4)	(5)
Sovereign Default _{$t-1$} *		-0.126*		-0.089	-0.085*
Bank Bondholdings _{$t-1$}		(0.078)		(0.058)	(0.050)
Sovereign Default _{$t-1$} *			-0.038**	-0.036***	-0.046***
Creditor Rights _{$t-1$}			(0.015)	(0.012)	(0.012)
Sovereign Default _{$t-1$} *					-0.174**
Openness _{$t-1$}					(0.073)
Bank Bondholdings _{$t-1$}		-0.060		-0.002	-0.011
		(0.057)		(0.045)	(0.044)
Creditor Rights _{$t-1$}			0.023	0.059***	0.046**
			(0.016)	(0.017)	(0.017)
Openness _{$t-1$}					-0.027
					(0.023)
Sovereign Default _{$t-1$}	-0.025*	-0.024	0.023	0.033	0.237***
	(0.013)	(0.020)	(0.026)	(0.026)	(0.085)
Banking Crisis _{$t-1$}	-0.041***	-0.009	-0.042***	-0.009	-0.009
	(0.012)	(0.012)	(0.013)	(0.015)	(0.014)
GDP p.c. Growth _{$t-1$}	0.082**	0.099	0.077*	0.086	0.079
	(0.039)	(0.098)	(0.040)	(0.097)	(0.085)
Unemployment Growth _{$t-1$}	-0.040***	-0.072**	-0.046***	-0.067**	-0.064**
	(0.012)	(0.032)	(0.013)	(0.028)	(0.026)
Default Risk _{$t-1$}	-0.019	0.022	-0.018	-0.053	-0.009
	(0.042)	(0.035)	(0.048)	(0.035)	(0.037)
Inflation _{$t-1$}	-0.000	-0.000	-0.000*	-0.000	-0.000
	(0.000)	(0.000)	(0.000)	(0.000)	(0.000)
Exchange Rate	0.005**	0.074	0.005**	0.048	0.028
Depreciation _{$t-1$}	(0.002)	(0.051)	(0.002)	(0.051)	(0.049)
Sudden Stop _{$t-1$}	-0.011	-0.036*	-0.016	-0.033	-0.022
	(0.028)	(0.020)	(0.029)	(0.022)	(0.020)
Constant	0.002	0.031	-0.046	-0.120***	-0.009
	(0.032)	(0.035)	(0.067)	(0.040)	(0.063)
Time Dummies?	Yes	Yes	Yes	Yes	Yes
Country Dummies?	Yes	Yes	Yes	Yes	Yes
No Observations	686	252	606	188	188
No Countries	46	36	46	35	35
No Defaults	54	22	52	22	22
R-squared	0.138	0.189	0.156	0.248	0.286

Table III: Determinants of Sovereign Defaults

The table presents probit regressions for 20 countries over the 1980-2005 period. The dependent variable is the probability that the country is in default in year t . The reported coefficients are estimates of the effect of a marginal change in the corresponding regressor on the probability of sovereign default, computed at the average of the dependent variable. Creditor rights is a discrete index ranging from 0 to 4 aggregating creditor rights, following La Porta et al. (1998) and Djankov et al. (2007). Capital flows is computed as (private liabilities over GDP in year t) - (private liabilities over GDP in year $t-1$). Regressions include year fixed effects; standard errors are adjusted for heteroskedasticity using the Huber (1967) and White (1980) correction. P-values are reported in parentheses below the coefficient estimates. *** indicates significance at the 1% level; ** indicates significance at the 5% level; * indicates significance at the 10% level.

	(1)	(2)	(3)	(4)	(5)
Bank Bondholdings _{$t-1$}	-0.157** (0.024)			-0.259*** (0.003)	-0.010*** (0.000)
Creditor Rights _{$t-1$}		-0.037* (0.053)		-0.056** (0.017)	-0.002*** (0.004)
Capital Flows _{$t-1$}			-0.318* (0.080)		-0.031*** (0.000)
Banking Crisis _{$t-1$}	0.373*** (0.001)	0.090* (0.055)	0.089** (0.025)	0.402*** (0.001)	0.435*** (0.000)
GDP p.c. Growth _{$t-1$}	-0.125 (0.324)	-0.141 (0.305)	-0.345** (0.015)	-0.147 (0.311)	-0.030*** (0.000)
Default Risk _{$t-1$}	0.736*** (0.000)	0.465*** (0.000)	0.463*** (0.000)	0.768*** (0.000)	0.032*** (0.000)
Short Term Debt _{$t-1$}	0.000** (0.010)	0.000 (0.457)	0.000 (0.239)	0.000** (0.013)	0.000*** (0.001)
Foreign Reserves _{$t-1$}	0.008*** (0.006)	-0.006 (0.136)	-0.006 (0.105)	0.010*** (0.003)	0.001*** (0.000)
No Observations	122	288	305	122	122
No Countries	15	20	20	15	15
No Defaults	29	61	61	29	29
Pseudo R-squared	0.480	0.347	0.364	0.514	0.628

Internet Appendix to “Sovereign Default, Domestic Banks, and Financial Institutions”*

A. Data Appendix

In this Appendix we report details of our sample and of our estimation procedure. Our baseline sample period is 1980-2005, and the countries included are Algeria, Argentina, Australia, Austria, Belgium, Brazil, Bulgaria, Canada, Chile, Colombia, Costa Rica, Czech Republic, Denmark, Finland, France, Germany, Greece, Hungary, Indonesia, Ireland, Israel, Italy, Japan, Kuwait, Malaysia, Mexico, Morocco, New Zealand, Norway, Panama, Philippines, Poland, Portugal, Romania, Saudi Arabia, Singapore, Slovak Republic, Slovenia, South Africa, Spain, Sweden, Switzerland, Thailand, Turkey, United Kingdom, and United States. Defaulting countries of English common law legal origin are: Jamaica, Kenya, Malawi, Nigeria, Pakistan, Sierra Leone, South Africa, Tanzania, Uganda, Yemen, Zambia, and Zimbabwe. All of these countries drop out of our estimated regressions once we adjust for our control variables, which prevent us from using legal origin as an instrument for the quality of institutions. More generally, for our study data availability implies a sample period of 1980-2005 for regressions without creditor rights, and of 1980-2003 otherwise. Further data limitations related to the availability of control variables restrict the sample period to start in 1986 in some specifications. We focus on the following SP definition of sovereign default: “the failure to meet a principal or interest payment on the due date (or within the specified grace period) contained in the original terms of the debt issue. In particular, each issuer’s debt is considered in default in any of the following circumstances: (i) For local and foreign currency bonds, notes and bills, when either scheduled debt service is not paid on the due date, or an exchange offer of new debt contains terms less favorable than the original issue; (ii) For central bank currency, when notes are converted into new currency of less than equivalent face value; (iii) For bank loans, when either scheduled debt service is not paid on the due date, or a rescheduling of principal and/or interest is agreed to by creditors at less favorable terms than the original loan. Such rescheduling agreements covering short and long term debt are considered defaults even where, for legal or regulatory reasons, creditors deem forced rollover of principal to be voluntary.” This definition has several advantages, including the fact that it covers the most comprehensive set of countries over the time period we study, and it is widely used in the literature. At the same time, we wish to note that, while there is broad consensus on what constitutes a default, and this broadly corresponds to the SP definition, there is by no means unanimity in the literature and different studies have sometimes used slightly different categorizations regarding certain aspects of the definition of a sovereign crisis (see Reinhart and Rogoff (2010) for an account of this). Among the various issues involving any empirical definition of a sovereign default episode, one has to do with dating the beginning of the episode, and the other has to do with its length. We discuss these in turn. In particular, the dating of a sovereign default episode can be controversial in certain crises. On the one hand, the time of default is in general accurately classified as a crisis year, and there is broad consensus across scholars on the date in which a sovereign default occurs. Importantly for our purposes, the SP definition appears to capture this consensus, particularly so once one agrees to

*Citation format: Gennaioli, Nicola, Alberto Martin, and Stefano Rossi, [year], Internet Appendix to “Sovereign Default, Domestic Banks, and Financial Institutions” *Journal of Finance* [vol #], [pages], <http://www.afajof.org/supplements.asp>. Please note: Wiley-Blackwell is not responsible for the content or functionality of any supporting information supplied by the authors. Any queries (other than missing material) should be directed to the authors of the article.

RS: Update when we get proofs, omitting square brackets.

include into the definition of a default also debt restructurings with worse terms for creditors. On the other hand, there is a large variation in the length of a sovereign default episode, and the final resolution of a sovereign default is sometimes controversial, and particularly so for default episodes with the longest durations. Early examples include Russia’s default following the revolution, which lasted more than six decades, Greece’s default in 1826 that shut it out from international capital markets for more than five decades, and Honduras’s 1873 default with a comparable duration. Looking more directly at our sample, there are several defaulting countries with long renegotiation periods, including for example the Democratic Republic of Congo (25 years), the Democratic Republic of Korea (25), Nicaragua (25), Honduras (24), Guyana (23), Central African Republic (23 years), Congo (22 years), Madagascar (22), Angola (20), and Mozambique (20). For our purposes of looking for evidence consistent with our theoretical mechanism, we treat every year of a default episode as a default, as we are interested in gauging the effect of a sovereign default crisis on private credit, and we note that banks may have difficulty refinancing during the whole spell of a default episode. That is, the difficulty of banks to refinance during default renegotiation is consistent with our theoretical mechanism and our hypotheses. At the same time, there might be a concern that the intensity of a default, that is, the length of a default episode and of the associated renegotiation may be an important omitted variable, driving some of the results. However, we note that in our regression analysis, once we adjust for a number of appropriate control variables, we are left with a much smaller number of country-years in default. For example, regressions 1 and 3 of Table II have 12 countries in default, for a total of 54 and 52 country-years in default, respectively, and an average duration of about 4.3/4.5 years; regressions 2 and 3 of Table III have 14 countries in default, for a total of 61 country-years in default, and an average duration of about 4.3 years. As a result, we are not concerned that our results are driven by abnormally long renegotiation periods. The reason is that defaulting countries with very long renegotiation periods, such as all those with default episodes of 15 years or longer, all drop out of the sample once we appropriately adjust for control variables. In other words, in our regressions there is very little variation in the extent of default renegotiation; hence this is unlikely to drive our results. In a related vein, in our paper we wish as much as it is possible to avoid identifying our effects from crises that are of controversial attribution. We have seen already above that sovereign default crises with long renegotiation periods, on which some crises years may be of potentially controversial attribution, drop out of the sample once we adjust for appropriate control variables. Therefore, while we still use the SP definition as our baseline definition, for each sovereign default episode that is included in our regressions, we thoroughly check the literature to find out whether a country-year observation’s designation as part of a sovereign default episode is undisputed or whether it is controversial. As noted above, this is potentially relevant for the ends of crisis, rather than for their beginning. We define a country-year observation as controversial if at least one source documents the observation as definitely not being part of a default episode; in such cases, we remove the observation from the sample. This procedure confirms that there is broad consensus on the SP attribution of country-years as default episodes, at least with respect to our samples in Tables II and III. We only find one observation, Costa Rica 1990, that is controversial in that Borensztein and Panizza (2008) and others treat it as the final year of a default episode, while Vásquez (1996) documents that Costa Rica made its Brady deal in 1989 and exited default in that year, so that it was not in default in 1990. We resolve this controversy by dropping the observation of Costa Rica 1990. We then compute our variable banks holdings of government debt. Following Kumhof and Tanner (2008), we define the exposure of banks to government debt as the following ratio: $Banks' Bondholdings = \frac{Financial\ Institutions' Net\ Credit\ to\ Government}{Financial\ Institutions' Net\ Total\ Assets}$. The figures are computed from International Financial Statistics. The numerator is the sum of all entries representing net credit to the public sector by deposit money banks, other banking institutions and nonbank financial institutions. The denom-

inator is the sum of the net total assets of these three groups, after canceling out credit items between them. To obtain the net figures we deduct from both numerator and denominator the sum of all entries representing credit by the public sector to these institutions. To compute the variable for a country-year we require that all data items are available, that is, if one item is missing we treat the banks' bondholdings variable as missing as well. Furthermore, given that we want to identify our effects from cross-sectional variation in bank bondholdings, we check our data to see if there are cases of countries in which banks sharply increase their bondholdings during a period of sovereign default and debt crises, and we exclude country-year observations in which private credit and bondholdings change by more than 100%. This procedure eliminates the observations of Algeria 1992 and 1993, during which private credit declined by 111% and bondholdings increased from 2.9% to 56.9% of banks' assets. Finally, we define our sudden stop dummy variable. Following Calvo et al. (2003), we define a sudden stop as a year in which there is both a reduction in the current account deficit by more than 5%, and GDP per capita growth is negative in the same year. We also wish to point out that the literature is not unanimous in empirically defining sudden stops in the data. As a result, we also adopt other approaches, such as trying different thresholds, or using the (continuous) change in current account deficit, based on the work of Guidotti et al. (2004) and others, and our results are unaffected. Interestingly, in our sample the correlation between these sudden stop dummies and sovereign defaults is always between 5% and 12% depending on the definition of sudden stop. Many sudden stops in our sample, such as the so-called Tequila crisis in Mexico in the mid 1990s, were not associated with sovereign defaults.

REFERENCES

- Borensztein, Eduardo, and Ugo Panizza, 2008, The costs of sovereign default, IMF working paper.
- Calvo, Guillermo A., Alejandro Izquierdo and Luis-Fernando Mejia, 2003, On the empirics of sudden stops: The relevance of balance-sheet effects, NBER Working Paper 10520.
- Guidotti, Pablo Emilio, Federico Sturzenegger, and Agustin Villar, 2004, On the consequences of sudden stops, *Economia* 4, 171–214.
- Kumhof, Michael, and Evan Tanner, 2008, Government debt: A key role in financial intermediation, in Reinhart, C., C. Vgh, and A. Velasco, eds.: *Money, Crises and Transition, Essays in Honor of Guillermo A. Calvo*.
- Reinhart, Carmen M., and Kenneth S. Rogoff, 2010, *This time is different: A panoramic view of eight centuries of financial crises* (Princeton, NJ: Princeton University Press).
- Vásquez, Ian, 1996, The Brady plan and market-based solutions to debt crises, *Cato Journal* 16, 233-243.

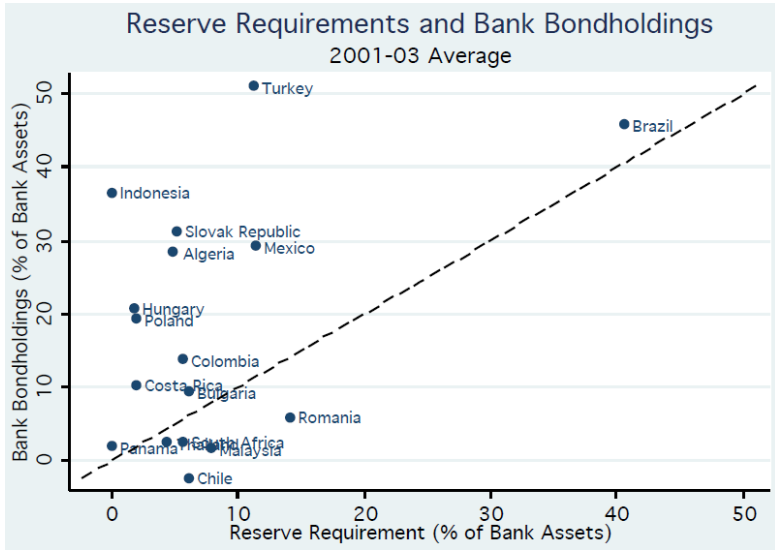

Figure A1. Reserve requirements and bank bondholdings.

Table AI – Description of the Variables used in the Analysis

Variable	Description
Private Credit to GDP	Ratio of credit from deposit taking financial institutions to the private sector (International Financial Statistics lines 22d and 42d) to GDP (International Financial Statistics line 99b), expressed as a percentage. Line 22d measures claims on the private sector by commercial banks and other financial institutions that accept transferable deposits such as demand deposits. Line 42d measures claims on the private sector given by other financial institutions that do not accept transferable deposits but that perform financial intermediation by accepting other types of deposits or close substitutes for deposits (e.g., savings and mortgage institutions, post office savings institutions, building and loan associations, certain finance companies, development banks, and offshore banking institutions). Source: International Monetary Fund, International Financial Statistics (September 2008).
Sovereign Default	Dummy variable that equals 1 if in year $t-1$ the sovereign issuer is in default. Sovereign default is defined as the failure to meet a principal or interest payment on the due date (or within the specified grace period) contained in the original terms of the debt issue. In particular, each issuer's debt is considered in default in any of the following circumstances: (i) For local and foreign currency bonds, notes and bills, when either scheduled debt service is not paid on the due date, or an exchange offer of new debt contains terms less favorable than the original issue; (ii) For central bank currency, when notes are converted into new currency of less than equivalent face value; (iii) For bank loans, when either scheduled debt service is not paid on the due date, or a rescheduling of principal and/or interest is agreed to by creditors at less favorable terms than the original loan. Such rescheduling agreements covering short and long term debt are considered defaults even where, for legal or regulatory reasons, creditors deem forced rollover of principal to be voluntary. Source: Standard & Poor's (2008).
Creditor Rights	An index aggregating creditor rights, following La Porta et al. (1998). A score of 1 is assigned when each of the following rights of secured lenders are defined in laws and regulations: First, there are restrictions, such as creditor consent or minimum dividends, for a debtor to file for reorganization. Second, secured creditors are able to seize their collateral after the reorganization petition is approved, i.e., there is no automatic stay or asset freeze. Third, secured creditors are paid first out of the proceeds of liquidating a bankrupt firm, as opposed to other creditors such as government or workers. Finally, if management does not retain administration of its property pending the resolution of the reorganization. The index ranges from 0 (weak creditor rights) to 4 (strong creditor rights) and is constructed as of January for every year from 1978 to 2003 following Djankov et al. (2007).
Openness	Ratio of total foreign liabilities over GDP. Source: Lane and Milesi-Ferretti (2007).
Banks' Bondholdings	Ratio of net claims to government, expressed as a percentage of financial institutions' net total assets. The numerator is the sum of all entries representing net credit to the public sector by deposit money banks, other banking institutions, and nonbank financial institutions, minus all credit by the public sector to these institutions. The denominator is the sum of the net total assets of these three groups, after canceling out credit items between them, minus all credit by the public sector to these institutions. Source: International Financial Statistics (2008).
Private Debt to GDP	Ratio of private, nonguaranteed external debt, which is an external obligation of a private debtor that is not guaranteed for repayment by a public entity. Source: World Development Indicators (September 2008).
Sudden Stop	Dummy variable that equals 1 if in year $t-1$ the current account deficit is reduced by more than 5%, and in the same year there is an output contraction.
Government Debt to GDP	Ratio of public debt, which is an external obligation of a public debtor, including the national government, a political subdivision (or an agency of either), and autonomous public bodies, expressed as a percentage. Source: World Development Indicators (September 2008).
GDP per Capita	Logarithm of gross national product per capita (Atlas method) from 1980 to 2005. Source: World Development Indicators (September 2008).
Unemployment	Annual percentage unemployment. Source: World Development Indicators (September 2008).
Inflation	Annual percentage inflation, GDP deflator. Source: World Development Indicators (September 2008).
Default Risk	An index assigning risk points as a decreasing function of the estimated foreign debt service, which in turn is expressed as a percentage of the sum of the estimated total exports of goods and services. The index ranges from 0 (low risk) to 10 (high risk). Source: International Country Risk Guide (ICRG).

Table AII – Bondholdings and Creditor Rights

The table presents panel regressions for 46 countries over the 1980-2005 period. The dependent variable bank bondholdings is computed as a percentage of banks' total assets. Creditor rights is a discrete index ranging from 0 to 4 aggregating creditor rights, following La Porta et al. (1998) and Djankov et al. (2007). *** indicates significance at the 1% level; ** indicates significance at the 5% level; * indicates significance at the 10% level.

	Country-Level Regressions			Bank-Level Regressions		
	(1)	(2)	(3)	(4)	(5)	(6)
Creditor Rights $t-1$	-0.021 ^{***} (.005)	-0.177 ^{***} (.041)	-0.177 [*] (.100)	-0.012 ^{***} (.001)	-0.015 ^{***} (.001)	-0.015 ^{***} (.004)
Constant	0.131 ^{***} (.011)	0.424 ^{***} (.084)	0.424 ^{**} (.199)	0.106 ^{***} (.002)	0.160 ^{***} (.022)	0.160 ^{***} (.018)
Year Fixed Effects?	No	Yes	Yes	No	Yes	Yes
Country Fixed Effects?	No	Yes	Yes	-	-	-
Bank Fixed Effects?	-	-	-	No	Yes	Yes
Robust Standard Errors?	Yes	Yes	Yes	Yes	Yes	Yes
Clustered Standard Errors?	No	No	Yes	No	No	Yes
No Observations	873	873	873	27,226	27,226	27,226
No Countries	83	83	83	105	105	105
Adjusted R ²	0.022	0.527	0.527	0.010	0.763	0.763

Table AIII - Reserve Requirements and Eligible Assets

	<i>Bondholdings</i>	Reserve Requirements	<i>Reserve Requirements</i>	Eligible Assets
	<i>Assets</i>		<i>Assets</i>	
Algeria	28.49	6.25% of demand and time deposits	4.90	
Brazil	45.90	60% of demand deposits, 30% of Advances on Export Contracts; 15% of time deposits; 20% of savings deposits	40.61	Cash, treasury bonds, deposits in central bank
Bulgaria	9.39	8% - based on deposits' volume acquired	6.14	Cash on current account by BNB
Chile	-2.33	9% for demand deposits; 3.6% for time deposits and an additional 10% for both	6.16	
Colombia	13.79	Cash reserve: "Fit into the Bank of the Republic on Checking accounts 13 %, Deposits of Saving 6 % and Certificates of deposit to Term 2.5 %."	5.62	
Costa Rica	10.32	5%	1.96	N.A.: Assume all bank deposits eligible
Hungary	20.84	5% of all sources of funds	1.84	
Indonesia	36.66	No reserve requirement	0.00	
Malaysia	1.63	4% of eligible liabilities	7.87	Government bonds, T-Bills, Cagamas bonds, Central Bank securities, development bonds, other eligible securities
Mexico	29.27	20% of banks' liabilities	11.42	Cash in domestic and foreign currencies, T-Bills, bonds issued by the government or other countries
Panama	1.96	No reserve requirement	0.00	
Poland	19.29	4.5%	1.82	N.A.: Assume all bank deposits eligible
Romania	5.94	18% of ROL deposits. 25% of deposits in foreign exchange kept in USD, EUR	14.11	Securities, bonds, cash, short term deposits
Slovak Republic	31.30	3%-5%	5.15	Demand deposits in SKK; demand deposits in foreign currency; term deposits in SKK; term deposits in foreign currency; bills of exchange issued by bank for non-bank clients; bond issued by bank for non-bank clients; other obligations to the clients; intrabank deposits of foreign banks dealt with by domestic commercial banks
South Africa	2.68	2.5% of adjusted liabilities as minimum reserve balance with the South African Reserve Bank; 5% of reduced liabilities as liquid assets.	5.60	Only domestic central government stock of any maturity
Thailand	2.46	6% of total deposits and total short-term foreign currency borrowing (< 1 year)	4.43	Government securities, bonds issued by the Central Bank, debentures, bonds, or promissory notes guaranteed by the Ministry of Finance; bonds or debt instruments guaranteed by other state corporations.
Turkey	51.13	6% of liabilities denominated in TRL and 11 % of liabilities denominated in foreign currencies. Also, 4 % of liabilities denominated in TRL and 1% of liabilities denominated in foreign currencies	11.19	Cash in vault, government paper, free deposits at Central Bank

Table AIV – Where Is Default More Costly?

The table presents panel regressions for 46 countries over the 1980-2005 period. The dependent variable private credit % flows is computed as $\ln(\text{private credit to GDP in year } t) - \ln(\text{private credit to GDP in year } t-1)$. Sovereign default is a binary variable that equals 1 if the sovereign is in default in year $t-1$, 0 otherwise. Creditor rights is a discrete index ranging from 0 to 4 aggregating creditor rights, following La Porta et al. (1998) and Djankov et al. (2007). Openness is computed as private liabilities over GDP. Sudden stop is a dummy that equals 1 if in the previous year the country has negative GDP per capita growth and its current account balance increases by more than 5%. *** indicates significance at the 1% level; ** indicates significance at the 5% level; * indicates significance at the 10% level.

	Private Credit % Flows				
	(1)	(2)	(3)	(4)	(5)
Sovereign Default $t-1$ *		-0.576 ^{***}		-0.461 [*]	-0.422 [*]
Bank Bondholdings $t-1$		(0.214)		(0.252)	(0.235)
Sovereign Default $t-1$ *			-0.119 ^{**}	-0.002	-0.026
Creditor Rights $t-1$			(0.057)	(0.080)	(0.075)
Sovereign Default $t-1$ *					-0.772 ^{***}
Openness $t-1$					(0.191)
Bank Bondholdings $t-1$		-0.267 ^{**}		-0.050	-0.082
		(0.114)		(0.158)	(0.147)
Creditor Rights $t-1$			0.042 ^{**}	0.245 ^{***}	0.202 ^{***}
			(0.018)	(0.082)	(0.077)
Openness $t-1$					-0.045
					(0.047)
Sovereign Default $t-1$	-0.076 ^{***}	-0.041	0.087	-0.042	0.796 ^{***}
	(0.023)	(0.057)	(0.076)	(0.143)	(0.230)
Banking Crisis $t-1$				-0.044	-0.038
				(0.038)	(0.036)
GDP p.c. Growth $t-1$	0.274 ^{***}	0.679 ^{***}	0.294 ^{***}	0.715 ^{***}	0.699 ^{***}
	(0.053)	(0.209)	(0.059)	(0.253)	(0.235)
Unemployment Growth $t-1$	-0.052 [*]	-0.083	-0.060 [*]	-0.102	-0.106
	(0.029)	(0.061)	(0.031)	(0.076)	(0.072)
Default Risk $t-1$	0.108 ^{**}	0.035	0.125 ^{**}	0.296 ^{**}	0.151
	(0.042)	(0.100)	(0.049)	(0.147)	(0.141)
Inflation $t-1$	-0.000 ^{***}	-0.000 ^{***}	-0.000 ^{***}	-0.000 [*]	-0.000 [*]
	(0.000)	(0.000)	(0.000)	(0.000)	(0.000)
Exchange Rate	0.021 ^{***}	0.424 ^{**}	0.023 ^{***}	0.365 [*]	0.286
	(0.007)	(0.170)	(0.007)	(0.196)	(0.182)
Depreciation $t-1$					
Sudden Stop $t-1$	-0.082 ^{**}	-0.111 [*]	-0.083 ^{**}	-0.054	-0.018
	(0.038)	(0.058)	(0.041)	(0.065)	(0.061)
Constant	-0.077 ^{**}	-0.038	-0.185 ^{***}	-0.557 ^{***}	-0.197
	(0.037)	(0.101)	(0.058)	(0.201)	(0.206)
Time Dummies?	Yes	Yes	Yes	Yes	Yes
Country Dummies?	Yes	Yes	Yes	Yes	Yes
No Observations	686	252	606	188	188
No Countries	46	36	46	35	35
No Defaults	54	22	52	22	22
R-squared	0.333	0.373	0.334	0.433	0.466

Table AV – Propensity Score Estimation of the Effect of Sovereign Default on Private Credit Flows

This table reports one- and two-stage matching estimates of the “average treatment effect on the treated” for defaulting countries using a difference-in-differences matching estimator. The treatment indicator is 1 for country-years in which there is a sovereign default. The outcome variable is the change in private credit over GDP from year $t-1$ to t . The first stage in the two-stage models is a probit model of the propensity to default. The second-stage model for the matching estimators are multivariate regressions of the change in private credit on the treatment indicator and all independent variables included in the propensity equation. Panel A column 1 presents results from a one-stage estimation. Panel A, column 2 presents results from a two-stage estimation. The probit model’s independent variables in Panel A, column 2 are the banking crisis dummy, GDP per capita growth, unemployment growth, default risk, inflation, exchange rate depreciation, bank bondholdings, and creditor rights. Panel B presents results from two-stage estimates. In Panel B, the results are presented separately for the sample with below-median and above-median bank bondholdings in columns 1 and 2, respectively, and for the sample with low and high creditor rights (countries with creditor rights of 0 and 1, and countries with creditor rights of 2, 3, and 4, respectively) in columns 3 and 4, respectively. The probit models’ independent variables in Panel B are the same as in Panel A except bank bondholdings and creditor rights, which are excluded in the probit models of Panel B. *** indicates significance at the 1% level; ** indicates significance at the 5% level; * indicates significance at the 10% level.

Panel A – Post-default change in private credit over GDP, full sample

	Not Matched (1)	Matched (2)
Sovereign Default $t-1$	-0.013 ^{***} (.002)	-0.022 ^{**} (.012)
No Observations	4,543	194
No Defaults	591	16

Panel B – Post-default change in private credit over GDP, by bondholdings and by creditor rights, matched

	(1)	(2)	(3)	(4)
	Low Bondholdings	High Bondholdings	Low Creditor Rights	High Creditor Rights
Sovereign Default $t-1$	-0.017 (.023)	-0.023 [*] (.013)	-0.007 (.012)	-0.027 [*] (.015)
No Observations	104	146	251	359
No Defaults	9	8	30	7