

# Reviews of Human Factors and Ergonomics

<http://rev.sagepub.com/>

---

## **Space Telerobotics: Unique Challenges to Human–Robot Collaboration in Space**

Terrence Fong, Jennifer Rochlis Zumbado, Nancy Currie, Andrew Mishkin and David L. Akin

*Reviews of Human Factors and Ergonomics* 2013 9: 6  
DOI: 10.1177/1557234X13510679

The online version of this article can be found at:  
<http://rev.sagepub.com/content/9/1/6>

---

Published by:



<http://www.sagepublications.com>

On behalf of:



[Human Factors and Ergonomics Society](http://www.hfes.org)

**Additional services and information for *Reviews of Human Factors and Ergonomics* can be found at:**

**Email Alerts:** <http://rev.sagepub.com/cgi/alerts>

**Subscriptions:** <http://rev.sagepub.com/subscriptions>

**Reprints:** <http://www.sagepub.com/journalsReprints.nav>

**Permissions:** <http://www.sagepub.com/journalsPermissions.nav>

**Citations:** <http://rev.sagepub.com/content/9/1/6.refs.html>

## CHAPTER 1

# Space Telerobotics: Unique Challenges to Human–Robot Collaboration in Space

**Terrence Fong, Jennifer Rochlis Zumbado, Nancy Currie,  
Andrew Mishkin, & David L. Akin**

In this chapter, we survey the current state of the art in space telerobots. We begin by defining relevant terms and describing applications. We then examine the design issues for space telerobotics, including common requirements, operational constraints, and design elements. A discussion follows of the reasons space telerobotics presents unique challenges beyond terrestrial systems. We then present case studies of several different space telerobots, examining key aspects of design and human–robot interaction. Next, we describe telerobots and concepts of operations for future space exploration missions. Finally, we discuss the various ways in which space telerobots can be evaluated in order to characterize and improve performance.

---

## INTRODUCTION

### Context and Motivation

Future space missions in Earth orbit, to the moon, and to other distant destinations offer many new opportunities for exploration. However, astronaut time is always limited and some work is not feasible or efficient for humans to perform. Robots, however, can complement human explorers, performing work under remote control from Earth, orbit, or nearby habitats. A central challenge, therefore, is to understand how humans and robots can work efficiently and effectively together in order to maximize performance, improve scientific return, and increase mission success.

Telerobots can take various forms and do a variety of work to increase the productivity of space exploration. They are well suited to performing tasks (surveys, routine maintenance, etc.) that are tedious, highly repetitive, dangerous or long duration, such as advance scouting, site preparation, and habitat construction that help prepare for future human activity. Telerobots can also assist humans side by side during activities and perform follow-up work, completing tasks started by humans or executing tasks that complement and supplement prior human work.

---

**Keywords:** field robotics, human–robot interaction, International Space Station, planetary rover, space robotics, telemanipulation, teleoperation, telerobotics

*Reviews of Human Factors and Ergonomics*, Vol. 9, 2013, pp. 6–56. DOI 10.1177/1557234X13510679. Not subject to U.S. copyright restrictions.

## Definitions

Sheridan (1995) defined a *robot* as “a machine that senses and acts upon its environment autonomously, and . . . behaves with what appears to be human intelligence” (p. 205). Sheridan used this definition to distinguish a robot from a *teleoperator*, which he defined as “a machine enabling a human operator to move about, sense, and mechanically manipulate objects at a distance” (Sheridan, 1995, p. 205). Sheridan further distinguished a *telerobot* as a “subclass of teleoperator in which the machine acts as a robot for short periods, but is monitored by a human supervisor and reprogrammed from time to time” (Sheridan, 1995, p. 205).

Telerobot control can be considered on a sliding scale of *operator* (human) involvement, from manual control to supervisory control. With *manual control* (sometimes called *direct teleoperation*), the operator effects remote control of actuators on the robot. Remote driving of a vehicle using joysticks and rate control and remote positioning of a manipulator arm using a force-reflecting master/slave controller are examples of manual control. With *supervisory control*, the operator intermittently commands and monitors an automated system, intervening only when necessary. The remote operation of the Mars Exploration Rovers (MERs; Spirit and Opportunity) by daily “uplink” of command sequences and “downlink” of recorded data is an example of supervisory control.

For the purposes of this chapter, we define a *space telerobot* as “a remotely operated robot that performs work in a rich space environment” (Figure 1.1). A rich space environment can be an unstructured surface (planet, asteroid, etc.) or a complex operational setting (e.g., on-orbit servicing of a satellite). We further define *remotely operated* as “operated by humans in space, or on the ground, using any mode from manual to supervisory control.” By these definitions, remotely operated planetary rovers, manipulator arms, and highly maneuverable free-flying systems are all space telerobots. Deep-space probes, orbiters, landers, and automated spacecraft, however, are not. Hybrid systems are also possible. The Space Shuttle, for example, is a spacecraft equipped with a space telerobot, the Shuttle Remote Manipulator System (SRMS).

## Applications

Space telerobots can perform a variety of intravehicular activity (IVA) and extravehicular activity (EVA) work for missions in orbit, in deep space, or on surface environments (Ambrose et al., 2012). Future mission scenarios include low Earth orbit (LEO) maintenance, libration point telerobotics, near-Earth objects (NEO) expeditions, Mars transit, planetary surface exploration, and satellite servicing. To support these missions, a wide range of telerobots is required. Planetary rovers can be used to perform scientific fieldwork, conduct site surveys, prepare work sites, and place instrumentation. Construction-class robots, such as the large manipulators on the Space Shuttle and International Space Station (ISS), are useful for assembling structures and modules as well as deploying payloads. Dexterous manipulators can be used to perform routine maintenance, servicing, and work that requires human-level dexterity. Free-flying telerobots can provide extreme mobility and are suitable for a wide range of mobile sensor tasks.

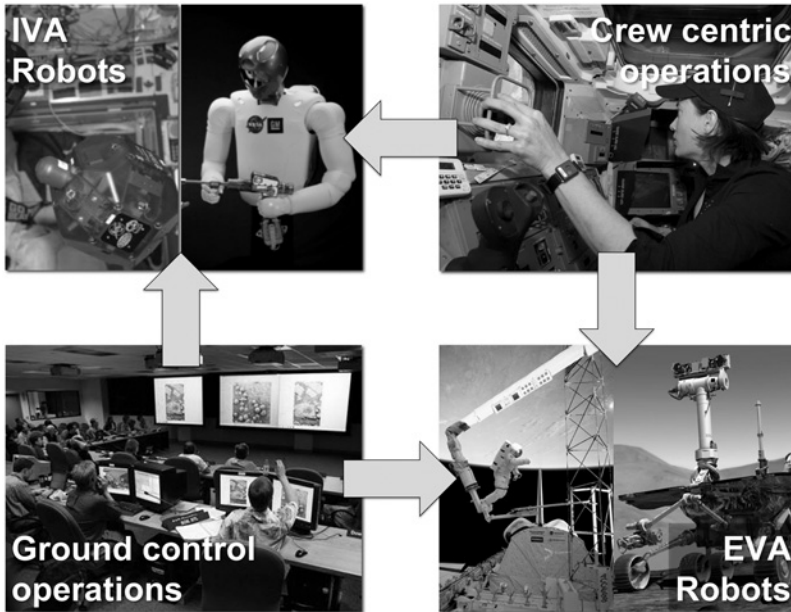

**Figure 1.1.** Space telerobots are used for intravehicular and extravehicular tasks. Remote operation can be performed by ground controllers on Earth or by humans in space using a variety of control modes, interfaces, and displays. Clockwise from top left: SPHERES robotic free-flyer and Robonaut 2 humanoid robot; Canadarm controls inside the Space Shuttle; Canadarm manipulator and Mars Exploration Rover (MER); MER ground control team. Source: National Aeronautics and Space Administration.

Telerobots have been used in space since the 1970s. The Lunokhod 1 rover landed on the moon in November 1970 and was followed by Lunokhod 2 in January 1973 (Kemurdjian, 1993). The Lunokhods were remotely operated from Earth and carried a variety of cameras and instruments to explore the lunar surface. The SRMS, or Canadarm, was first used during the second Space Shuttle mission in November 1981 (Sachdev, 1986). The SRMS was used throughout the duration of the Space Shuttle program to maneuver payloads in, and out, of the payload bay. In 1993, the ROTEX manipulator was flown on the Space Shuttle as a payload experiment (Hirzinger, Brunner, Dietrich, & Heindl, 1994). ROTEX was remotely operated by astronauts as well as by ground controllers. In late 1997, the Mars Pathfinder mission deployed the Sojourner rover to explore the surface of Mars with cameras and a spectrometer (Shirley & Matijevic, 1995).

More recently, there has been a dramatic increase in the use of space telerobots. In January 2004, the MERs Spirit and Opportunity, landed on Mars (Bell, 2010). Spirit was remotely operated from Earth until 2010; Opportunity continues to function after more than 8 years on Mars. The two rovers have enabled extensive geological analysis of Martian rocks and planetary surface features to be performed. In March 2008, the Canadian Space

Agency's (CSA) Special Purpose Dexterous Manipulator (SPDM) was added to the outside of ISS. The SPDM is designed to perform tasks that previously required the crew to space-walk (Hunter, Darlington, Krukewich, & Laurenzio, 1993). In February 2011, the National Aeronautics and Space Administration's (NASA) Robonaut 2 (R2) was installed inside the ISS. R2 is a humanoid robot that is designed to offload routine and repetitive work from astronauts, such as in-flight maintenance (Diftler et al., 2011). In August 2012, the Mars Science Laboratory, Curiosity, landed on Mars. Curiosity is an automobile-sized planetary rover that is designed to remotely explore 20 to 50 times more area than either of the MER rovers (Grotzinger et al., 2012).

## Human–Robot Teams in Space

NASA has traditionally used different concepts of operation for human and robotic missions (Mishkin, Lee, Korth, & LeBlanc, 2007). Typical robotic exploration missions rely on meticulously scripted and validated command sequences that are intermittently uplinked by mission control to the robot for independent execution (Mishkin, Limonadi, Laubach, & Bass, 2006). In contrast, human spaceflight missions conducted with the Space Shuttle and ISS use near-continuous communication (data and voice) with minimal time delays (i.e., less than a few seconds). During missions, astronauts work in concert with engineers in mission control to perform tasks and resolve problems in real time.

The emergence of highly dexterous robots, such as R2, increases the opportunity for designing missions with human–robot teams. Human–robot teams bring together multiple types of agents, both human and robotic, with unique capabilities and capacities that complement each to promote mission success. Tasks that are considered “dull, dirty, or dangerous” can be transferred to robots, thus relieving human crew members to perform more complex tasks or those requiring real-time modifications due to contingencies. Additionally, due to the limited number of astronauts anticipated to be scheduled on planetary exploration missions, as well as their constrained schedules while in space or on the lunar surface, ground personnel will likely need to assist and remotely supervise some robotic agents (Hambuchen et al., 2006).

Since the coordination of a heterogeneous team of humans and robots is complex, a flexible architecture that allows each agent to have multiple command paths and degrees of automation is desired (Fong et al., 2005; Rehnmark, Currie, Ambrose, & Culbert, 2004). Although astronauts provide unmatched cognitive capabilities, operational flexibility, and dexterity, an overarching objective of human–robot teaming should be to employ human crew members as safely and efficiently as possible. This construct conserves consumables and limits the exposure of astronauts to the hazardous space environment.

However, another factor to consider is that robots typically take longer to perform the same task as humans. In order to demonstrate that human–robot teams are efficient and practical, a multiagent team must demonstrate efficient use of available resources within a reasonable period of time, reduce the risk of mission operations, and/or compensate for human limitations (reach, force, etc.). For example, EVA suit systems typically encumber an astronaut's range of motion, reach, and field of view. A robotic agent may be designed with enhanced physical capacities compared to a suited astronaut.

## DESIGN

At present, there are few standards, or guidelines, for the design of space telerobots. Even at the lowest level, common specifications for mechanical (attachment points, fixtures, etc.) interfaces and electrical interfaces (connectors, signals, etc.) do not exist. Although the Consultative Committee for Space Data Systems (CCSDS) has made some progress in developing international “recommended standards” for space communications and data handling, little has been done to develop consensus guidelines for human–robot interfaces and operational methodologies (Ferketic et al., 2006a, 2006b). A nascent CCSDS effort to develop interoperability standards between space agencies for telerobotics, with focus on data messaging and information exchange, was only recently started.

The design of all space telerobots must take into consideration adaptability, flexibility, reliability, maintainability, and training (for both ground controllers and crew) as well as interoperability with other space systems, such as communications and ground data systems. Moreover, the creation of any particular space telerobot requires satisfying detailed requirements for its intended mission and use. In the following, we discuss some of the common requirements, constraints, and elements that influence the design of space telerobots.

### Common Requirements

Since 1970, there have been less than a dozen fully operational space telerobots, not including “robotic” spacecraft (interplanetary probes, satellites/orbiters, and landers). These systems have all been unique, custom, extremely expensive, and difficult (if not impossible) to repair. Moreover, these systems have been operated in a highly conservative manner, with significant emphasis placed on mitigating risk wherever possible. In particular, design of control modes, user interfaces (displays and controls), and training procedures has focused on keeping remote robot operations strictly within defined limits.

As we have noted, there are many diverse applications and use cases for telerobots in space. However, whether a space telerobot operates in space or on a planetary surface, the tasks performed fall into two categories: *structured* or *unstructured*. A structured task is work that involves a well-defined routine and/or standardized sequence of operations. Structured tasks include assembly of space structures, payload deployment, docking of vehicles and payloads, external vehicle inspection, and routine maintenance. Structured tasks are often performed in space environments containing significant structure, particularly, man-made artifacts, including vehicle surfaces, connectors, beams and trusses, instruments and equipment, and so on. The ISS is a good example of a highly structured environment.

An unstructured task is work that involves ambiguity and uncertainty or for which no standardized procedures or routine practice exist. Unstructured tasks in space include contingency handling (emergency response), surface scouting, and work requiring dynamic planning. Unstructured tasks are often performed in natural environments (e.g., planetary surfaces) that have time-varying characteristics (illumination, surface composition, topography, etc.) or environments with unpredictable dynamic elements (wind, moving obstacles, etc.).

To date, space telerobots have typically been designed to perform either structured or unstructured tasks in space but not both. However, both task categories impose several common requirements on space telerobot operations. These operations must

- support multiple control modes,
- provide a user interface suitable for remote operation in space,
- have an operational concept that supports proficiency training, and
- support initial operations that occur long after fabrication, as the period from final preparation for launch to deployment in space can be a year (or more).

During the past two decades, there has been increasing integration of telerobots in human space missions. To date, this use has been limited to LEO missions, such as the ISS. As humans move beyond LEO, however, mission operations will shift from prescribed activities to a more flexible planning model, wherein astronauts will have responsibility for real-time task planning and replanning. This shift will affect allocation of tasks between humans and robots and require flexible and adaptable levels of automation, team-level goals, and scheduling.

## Constraints

**Space environment.** The space environment imposes numerous constraints on telerobot design and operation. Radiation, temperature extremes, illumination variations, micrometeoroids, and other environmental factors necessitate heavy emphasis on robustness and survivability. Hard vacuum and cold are dominant factors in orbit and in space. On planetary surfaces, the effect of dust, extreme highlights and deep shadows, and difficult topography must all be mitigated. Consequently, hardware systems (actuators, computing, and sensors) are typically lower performing in space.

For example, the Mars Science Laboratory *Curiosity* rover was launched in November 2011 and is equipped with two RAD750 processors, 256 MB of DRAM, and 2 GB of flash memory storage. The RAD750 is a radiation-hardened single-board computer that was first produced in 2001. The single-core units on the Mars Science Laboratory operate at 200 MHz. In comparison, the average consumer “smartphone” in 2013 is equipped with a dual (or quad) core processor operating at 1 to 1.5 GHz. Contemporary consumer desktop computers typically feature 8 to 16 core processors operating at 3 to 4 GHz.

Sustainability is a major factor for space telerobots. When possible, repair and maintenance are far more costly to perform in space than on Earth. Consequently, space telerobots are generally designed for graceful degradation due to component failure throughout their operational lifetimes. For example, the MER Spirit successfully operated for 4 additional years following the failure of the right-front wheel drive motor (Leger et al., 2005).

**Data communications.** Data communications imposes design constraints on space telerobots in several key ways. For Earth-based operators, round-trip transmission latency can range from a few hundred milliseconds (ground to LEO) to tens of minutes (Earth to Mars). Communication bandwidth for conventional space links ranges from a few hundred bits per second (bps) to a few megabits per second (Mbps). Free space



optical (laser) communications can potentially provide higher link rates to deep space but will likely be subject to numerous performance limiting factors, including atmospheric absorption, interference from background light sources, and pointing accuracy. Finally, intermittent loss of signal (LOS) and variable quality of service routinely occur due to orbital geometry, solar activity, and so on.

Each of these communication constraints can have a significant impact on operational design, particularly in terms of modes of control, telemetry design, and operations tempo. For example, direct teleoperation (manual control) with force reflection and real-time, high-resolution stereo video is possible only with a very-low-latency (0 to 25 ms) and high-bandwidth (3 Mbps or greater) communications link. For deep-space robots remotely operated from Earth, such as the Mars rovers, supervisory control and command sequencing is likely to remain the only practical method for space telerobots.

**Human performance in space.** Depending on the control mode and how tightly coupled system performance is to operator proficiency, human performance in space can impose several constraints on space telerobot design. For example, sensorimotor performance, particularly, degraded levels due to transient conditions (e.g., transition between different gravity conditions) or long exposure to the space environment (reduced gravity, radiation, etc.), can severely compromise the effectiveness and efficiency of astronaut manual control of a telerobot (Jones & Fiedler, 2010).

Moreover, some astronauts have reported experiencing cognitive impairment, or “space fog,” which may manifest in a variety of symptoms, including disorientation, befuddlement, mental slowing, poor concentration, and confusion. There are many possible reasons these symptoms could occur in space, including fatigue, stress, the novelty of the environment, gravity transients, and so on (Welch, Hoover, & Southward, 2009). For space telerobots, space fog can constrain operations because of reduced operator efficiency to perform spatial reasoning, strategic-level planning, and decision making.

## Design Elements

**Operational concepts.** Historically, different operational concepts have been employed in human and purely robotic missions (Mishkin et al., 2007). Human missions, such as the Space Shuttle and ISS, have all been conducted with near-continuous communication (data and voice) and minimal delay. Telerobotic operations have focused on positioning of external payloads with robotic manipulators, multiple cameras, and manual control. These activities generally follow preplanned scripts and schedules, which are used for ground-based training and then on-orbit manual execution.

In contrast, robotic missions have traditionally centered on the use of supervisory control in the presence of high delay (tens of minutes). For these missions, carefully designed and validated command sequences are intermittently uplinked by mission control to the robot for autonomous execution. The robot (e.g., a planetary rover on Mars) functions independently for long periods without communication to operators at mission control.

In addition to the differences between human and robotic missions, there are two categories of human–robot team configuration: ground control and crew-centric (Figure 1.1). With ground control operations, an Earth-based team performs planning,



operations, and analysis of robot task execution. The ground control team may take various forms but generally consists of a primary robot operations team supported by “back-room” support teams (science, robot engineering, etc.).

Ground control teams are social structures (Vertesi, 2012). As such, the sharing of information and the flow of control (particularly, decision making) is tightly tied to team size, organization, and hierarchy. For example, the MERs employ a surface operations approach that integrates science and engineering groups with a wide variety of expertise to perform tactical and strategic planning. This approach required the development of specialized processes for telemetry analysis, activity planning, visualization, and command sequence generation, integration, and validation (Mishkin et al., 2006).

With crew-centric operations, astronauts perform planning, execution, contingency handling, and analysis. Ground control may support the crew on an intermittent and/or time-delayed basis. This operational concept is appropriate in three situations: (a) poor, delayed, or intermittent communication prevents ground control from performing the task; (b) the crew’s physical presence at the robot site is critical to performing the task; or (c) local operations significantly outperform remote operations (e.g., number of commands per unit time).

For example, astronauts on the Space Shuttle and ISS have routinely operated robotic manipulators to position, deploy, and service equipment and structures. Because the astronauts are in proximity, they are able to employ manual control with low latency and often have line of sight from the operator station to the robot. During robot operations, ground control provides support by monitoring robot subsystems (e.g., motor current), verifying the sequence of activities, and performing analysis to troubleshoot and diagnose contingencies.

As humans venture farther into space, however, future missions will need to combine aspects from all of the aforementioned operational concepts. In particular, planners of future missions will need to consider how to manage ground control and crew-centric operations, different time scales (real-time to highly delayed) for planning and execution, sharing and trading of control authority, coordination and sequencing of activities, and transfer of information.

**Autonomy.** As we have discussed, space telerobots are extremely costly to build, deploy, and repair. Consequently, it is essential that remote operations be designed to minimize risk and possible damage to (or loss of) the space robot. Moreover, in situations in which robots operate in proximity to crew or flight vehicles, it is critical that remote operations be carried out in a way that maximizes safety.

For these reasons, autonomy is primarily used in space telerobots to provide safeguarding. This safeguarding includes, but is not limited to, collision detection, hazard avoidance, resource management (e.g., power), and limit checking. Beyond safeguarding, autonomy is also routinely employed for low-level command sequence execution, which includes simple task execution (e.g., servo positioning), task monitoring, and fault identification.

More recently, high-level autonomy has begun to be employed in a limited manner. The primary use is to improve operational efficiency, particularly for science data collection. For example, the Automated Exploration for Gathering Increased Science (AEGIS) software on the MER Opportunity employs onboard data analysis techniques to automatically

select high-quality science targets and sequence imaging operations without human intervention (Estlin et al., 2012).

**Control modes.** In addition to addressing constraints associated with the space environment, data communications, and human performance, space telerobots must also support human–robot teaming across multiple spatial ranges. This includes shoulder-to-shoulder proximity (e.g., astronaut and robot in a shared space), line-of-sight interaction (crew in habitat, robot outside), over-the-horizon commanding (crew in habitat, robot far away), and/or interplanetary operations (ground control team on Earth, robot on planetary surface). Thus, a variety of control modes are employed for space telerobots.

The most common control modes are direct teleoperation (manual control) and command sequencing (supervisory control). Direct teleoperation is performed using hand controllers, real-time direct viewing (line of sight or video display), and position/rate control (actuators and/or resolved motion). To date, force and haptic feedback has not been employed with operational systems due to communications latency and jitter, which precludes stable force reflection, as well as the difficulty of physically grounding operators in microgravity.

Command sequencing is widely used with space telerobots. Many variations have been proposed and employed for manipulators and rovers. Command sequences are generally specified in terms of basic actuator or instrument commands. These commands include joint position, number of wheel rotations, image acquisition (with associated capture parameters), and so on. Supervision (monitoring) of sequence execution may be performed interactively in real time or in “playback,” depending on execution speed and communications latency.

**Mitigation approaches.** Several techniques are commonly used to mitigate the impact of space environment and operational factors on system performance. To compensate for communications delay and intermittent LOS, command sequencing is usually employed. Predictive display methods, including forward estimation of system state (Nielsen, Goodrich, & Ricks, 2007), can also be effective for some scenarios, for example, remote driving on static terrain.

To address problems associated with limited communications bandwidth, particularly for data downlink from robot to operator, data transfers are prioritized and ordered. Data prioritization often needs to involve consideration of multiple factors, including operational relevance (especially for contingency handling), scientific importance (for analysis, subsequent planning, etc.), data volume, data packaging (compression and partitioning), and so on (Castano, Estlin, Anderson, Gaines, & Castano, 2007).

To alleviate the impacts of human performance in space, including variation in proficiency and reduction of sensorimotor capabilities, supervisory control can be employed. This approach, however, provides only partial mitigation because some tasks are not amenable to automation. For situations in which manual control is employed, limit checking, command validation, and safeguarding can help prevent and correct errors. In the future, as human space missions become longer and venture farther from Earth, new mitigation

techniques will be needed to reduce the negative effects associated with intermittent use of telerobotics and lack of real-time operational support from ground control.

## Comparison With Terrestrial Systems

The design of space telerobots is similar in some aspects to the design of terrestrial systems. Military telerobots, such as unmanned aerial vehicles and unmanned ground vehicles, are costly, must operate in dangerous environments, and cannot be fully automated. Thus, military telerobots, like their space counterparts, must be operated in a manner that minimizes damage, loss, and the impact of operator error. Underwater telerobots (remotely operated vehicles, autonomous underwater vehicles, etc.) must contend with similar data communication issues (bandwidth, latency, availability, etc.) as space telerobots. Consequently, similar mitigation approaches (e.g., data buffering and retransmission) are appropriate for both domains.

There are, however, many key design differences between space and terrestrial telerobots. First, there are numerous “enabling factors” that are available to terrestrial telerobots but not to space telerobots. Terrestrial telerobots can take advantage of positioning infrastructure, such as GPS, to obtain position fixes. This capability greatly simplifies motion control and task planning. Terrestrial telerobots also can take advantage of current high-performance computing technologies, which enables more advanced autonomy and sensing capacities.

Second, the operational lifetime for a space telerobot is quite different from that of a terrestrial telerobot. The duration of a space mission may be quite long; thus space telerobots are generally designed for long-term use, with the additional constraint that opportunities for servicing and repair are either limited or nonexistent. The MER Spirit, for example, operated on Mars for more than 2,200 days before ceasing to function, most likely due to lack of electrical power after being stuck in soft soil with poor solar panel orientation during the Martian winter.

Third, because space telerobots are so costly to design, build, launch, and operate, they are generally considered to be irreplaceable. The Mars Science Laboratory rover mission, for example, cost \$2.5 billion (NASA, 2011), including \$1.8 billion for spacecraft development and science investigations and additional amounts for launch and operations. Thus, control modes and operational concepts place significant emphasis on mitigating risk, limiting errors, and minimizing the impact of faults. Moreover, space telerobots are routinely operated to end of life to get as much benefit (e.g., scientific return) from a system as possible.

Fourth, it is very difficult to fully practice (rehearse) operations of most space telerobots prior to deployment. Analog environments and model-based simulation are typically used to simulate in-space and planetary surface conditions (Garry & Bleacher, 2011). However, these methods are limited in accuracy and fidelity, particularly for duplicating terrain interaction and contingencies. Additionally, space telerobots are operated in far fewer numbers and far fewer times than similar terrestrial telerobots. To date, for example, only four planetary rovers have successfully been landed and remotely operated on Mars. Contrast this number with the many thousands of unmanned ground vehicles (e.g.,

iRobot Warrior, BAE Systems Gladiator, Foster-Miller Talon) that have been deployed and remotely operated in active combat zones.

Fifth, deep-space telerobotic systems may be subjected to an extended “cruise” phase of months or years before reaching the target environment, at which time complex deployment and reconfiguration of the systems may be required. For example, the MER was packaged as a free-flying spacecraft for interplanetary travel; the rover electronics controlled trajectory changes en route and orchestrated the vehicle’s entry, descent, and landing on Mars (Reeves & Synder, 2005). Once on the surface, many days were needed to unfold the rover into its mobility configuration, establish vehicle and instrument payload health, characterize the vehicle in its new environment, and begin its primary surface mission.

Finally, the ratio of operators to telerobots is very different between space and terrestrial telerobots. For ground control operations, space telerobots generally require a large team of operators to (a) minimize the potential for error and risk of mission loss; (b) support detailed analysis, system monitoring, resource modeling, and contingency handling; (c) handle the complexity inherent with space operations (deep-space communications, timing synchronization, operations scheduling, diagnostics and prognostics, etc.); and (d) application- and task-specific activities (e.g., field geology using robot-mounted science instruments). During the initial phase (90 days) of MER operations, for example, more than 300 people were involved with ground control operations (Parke & Mishkin, 2005). Even several years later, routine MER operations still require several dozen people to perform planning, execution, monitoring, and data handling.

## CASE STUDIES

### Space Station Remote Manipulator System (SSRMS)

**System summary.** The SSRMS, or Canadarm 2 (Figure 1.2), is the principal EVA robotic system used on the ISS (McGregor & Oshinowo, 2001). The SSRMS was launched on the Space Shuttle in April 2001 and was used extensively during on-orbit assembly of the ISS to install pressurized modules, truss structures, and other large elements and as a work platform for EVA astronauts. The 17.6-m (fully extended) manipulator arm consists of two booms with seven joints, each with a range of  $\pm 270^\circ$ , and two latching end effectors. It is capable of handling payloads up to 116,000 kg and has the ability to self-relocate to reach a large portion of the ISS. Power, data, and video are provided to payloads via the latching end effectors. Control and monitoring of the SSRMS is performed using one of two modular robotic workstations (RWS), each of which contains three video monitors, a display and control panel, a portable computer system, a cursor control device, and two 3-degree-of-freedom (DOF) hand controllers (Figure 1.3).

**Crew control.** Astronauts can remotely operate the SSRMS using a variety of control modes, including “single joint rate” (individual joint movement), end-point control, and automatic trajectory control. During payload operations, the end effector is used to

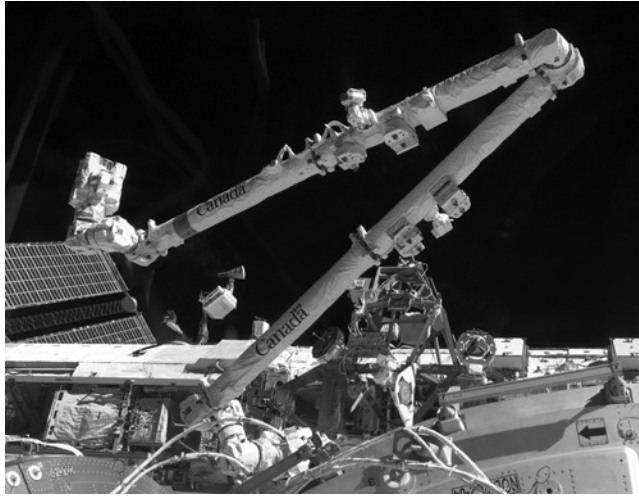

**Figure 1.2.** The Space Station Remote Manipulator System is a large robotic arm used to position astronauts, equipment, structures, and vehicles external to the Space Station. Source: National Aeronautics and Space Administration (ISS021-E-032817).



**Figure 1.3.** The robotic workstation is used by astronauts inside the Space Station to remotely operate the Space Station Remote Manipulator System. Source: National Aeronautics and Space Administration (ISS020-E-041812).

grapple a fixture on a component and maneuver it to an insertion point by moving the end effector and the attached orbital replacement unit (ORU) in its coordinate frame. ORUs are spare parts for the Space Station subsystems, many of which are externally mounted and robotically compatible. Manual control of the SSRMS is achieved by

manipulating the body-referenced axes at the end effector using the two separate hand controllers, one for three-axis translational control and one for control in the three rotational axes (pitch, yaw, and roll). An operator can command single-axis hand controller inputs or control up to all six axes simultaneously.

The RWS software provides operators with numerous options for selecting frames of resolution, command frames, and display frames. Understanding the various coordinate frames available for control of the SSRMS is essential for manual control and vigilance during automated operations, as the selection of coordinate frames from different points of reference can affect task complexity. For example, an operator can choose to have a display frame referenced to the ISS external environment while the control frame is referenced to the attached payload. This frame misalignment can potentially result in increased cognitive demand or contribute to incorrect commands during remote operations (Gugerty & Brooks, 2001, 2004). Optimum selection of these cues is determined by the position of the manipulator (or payload) with respect to the base structure, the vector of maneuver, and the availability of visual or other cues. Operations with a variety of control and display coordinate frames are performed during SSRMS operator training sessions, and recommended control and display frames of reference for specific tasks are denoted in crew procedures.

Astronauts must integrate and correlate information from multiple sensors as well as direct and indirect views of the work environment. Exocentric video cameras are mounted on the ISS to assist with external viewing during telerobotic operations. Views from manipulator-based cameras, such as a camera mounted on the SSRMS elbow, are particularly challenging to use since the point of reference constantly changes during manipulator motion. Also, the field of view of these cameras is limited and typically insufficient to provide a comprehensive representation of the work environment. Spatial awareness when using indirect viewing of teleoperation tasks can require significant cognitive demand if there is nonintuitive mapping of translational and rotational axes between the scene and the control input devices (Macedo, Kaber, Endsley, Powanusorn, & Myung, 1999; Wickens & Carsell, 2012). To address these issues, supplemental graphical displays, which can be viewed on laptop computers at the RWS, are often used to improve operator situation awareness.

The irregular structural geometry of the ISS combined with the constantly changing manipulator and payload positions and orientations can lead to misaligned conditions, which have been shown to degrade operator performance during remote manipulation and tracking tasks (Chintamani, Cao, Ellis, Tan, & Pandya, 2011; Menchaca-Brandan, Liu, Oman, & Natapoff, 2007). Similar issues with display-control misalignments have also been noted in analogous environments, such as surgical endoscopy (Klein et al., 2008). For space telerobots, operator performance issues arising from display-control misalignments have traditionally been managed through extensive operator training or by system-specific compensatory algorithms. Other alternate strategies and techniques, such as the use of augmented reality (AR), have also been shown to improve operator performance.

The use of AR virtual tethers to prompt control commands for maneuvering an ORU to an insertion location outside the view of ISS cameras was shown by Maida, Bowen, and Pace (2007) to improve operator performance as measured by task completion time and position/orientation alignment errors. Chintamani, Cao, Ellis, and Pandya (2010)

demonstrated that using AR to overlay the external ISS camera scenes with color-coded graphic translational and rotational coordinates mapped to the hand controller axes can assist the operator in developing an improved mental model of the remote robot's end effector pose and enhances an operator's awareness of display-control misalignments. AR can also be used to supplement video imagery to improve depth perception due to linear perspective (Chintamani et al., 2011).

**Ground control.** The original design of SSRMS operations required actuation of hardware switches located on the RWS to command joint motion or latching end effector operations. Consequently, ground-based operators were not initially able to remotely operate the SSRMS. Several factors, including the desire to preserve valuable on-orbit crew time for utilization activities (e.g., scientific research) and the reduction of the ISS crew size to two astronauts/cosmonauts during the grounding of the Space Shuttle following the Columbia accident, provided strong motivation to develop procedures and tools to enable ground control of the SSRMS.

Ground control of the SSRMS was first performed in 2005, enabling valuable on-orbit crew time to be reallocated to more critical tasks and activities. Modification of the system architecture and operational concepts were required as well as the implementation of stringent safety requirements prior to allowing shared control of ISS robotic systems (Rembala & Aziz, 2007). The safety of planned ground operations and SSRMS motion trajectories was first analyzed through the use of validated simulators. Detailed video surveys of the workspace surrounding the planned SSRMS trajectories were also performed to confirm that the actual environment matched the graphical models used in task simulations. One issue with commanding the SSRMS via ground control, which introduces additional complexity, is variable latency (approximately 3 to 10 s) in command and telemetry processing (Rembala & Aziz, 2007). To compensate for this latency, SSRMS ground control was limited to execution of automatic control sequences in either joint or Cartesian space. Although real-time operator input is not required in automatic modes of operations, operators must still maintain vigilance and situation awareness during arm motions. Ground-based operations are also limited to predicted periods of reliable communications between the ISS and mission control to ensure ground controllers can safely and effectively monitor the system and work environment.

After successfully demonstrating that ground control of the SSRMS could be accomplished safely by adhering to these planning and control measures, several routine, non-critical SSRMS operations were reassigned from the crew onboard ISS to ground controllers operating from the ISS mission control center in Houston. One operational approach that has been particularly successful is to defer the majority of SSRMS repositioning and stow actions to the ground control team (Aziz, 2010).

**Key SSRMS lessons learned.** Several key lessons have been learned over the first decade of teleoperations with the SSRMS. First, the complexity of positioning tasks has made it clear that no single control mode is sufficient for all operations. Multiple control modes are needed due to the unique nature of SSRMS operations, including ORU insertion or removal; EVA support, such as maneuvering or workplace stabilization of space-walking crewmembers; and alignment and berthing of major ISS elements or subsystems.



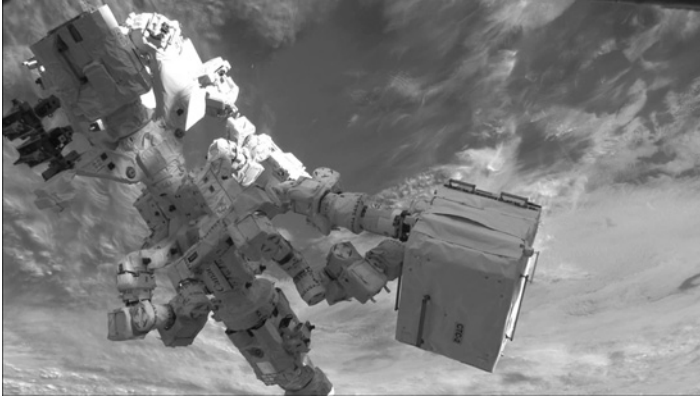

**Figure 1.4.** The Special Purpose Dexterous Manipulator performing an International Space Station external maintenance task.

Source: National Aeronautics and Space Administration.

The spatial complexity of the manipulator, irregular ISS geometry, and limited visibility from the operator/RWS location have highlighted the importance of providing operators with several options for handling frames of reference and graphical displays to enhance situation awareness in the work environment. Additional support tools to assist operators in determining and correcting display–control misalignments are also important. Finally, ground control of the SSRMS has shown that offloading routine tasks to the ISS ground control team can save valuable on-orbit crew time. However, ground control must compensate for variable latency and be sufficiently robust to safely continue operations during intermittent periods of loss of communications.

## Special Purpose Dexterous Manipulator (SPDM)

**System summary.** The SPDM, or Dextre, shown in Figure 1.4, was developed by the CSA (Hunter et al., 1993). Designed to support ISS external maintenance and utilization, SPDM tasks include replacing and relocating robotically serviceable ORUs, payload servicing, inspection and monitoring of the ISS exterior, and supporting EVAs. SPDM components were transported to the ISS on Space Shuttle Mission STS-123 in March 2008 and then assembled on orbit by astronauts.

The SPDM has two symmetrical seven-joint arms attached to a central body (Figure 1.5). Each arm is approximately 3.5 m in length and has 3 DOFs at the shoulder, 1 DOF at the elbow, and 3 DOFs at the wrist. The SPDM body can be rotated to facilitate optimal placement of the robot's arms at the work site. An ORU/tool change-out mechanism at the end of each arm has grippers for grasping equipment and tools, a socket drive to manipulate bolts, and power, data, and video connectivity to payloads. Attached to the main body is a tool holder assembly, which accommodates robotic interface tools and a temporary platform for storage and transportation of ORUs and payloads. The rated capacity of the system

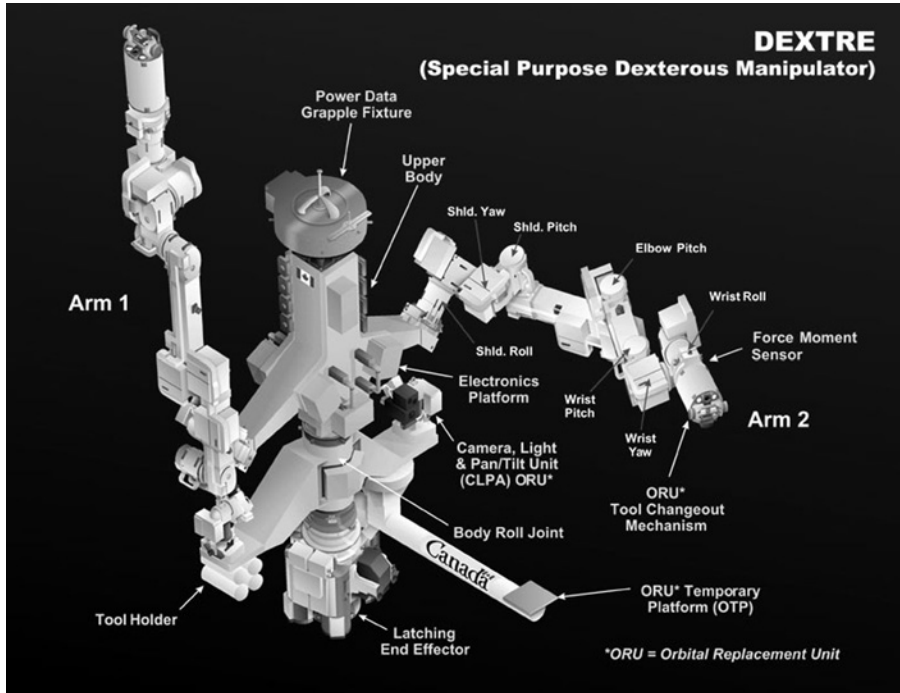

**Figure 1.5.** The Special Purpose Dexterous Manipulator includes two arms and fixtures for working with orbital replacement units and payloads.

Source: MD Robotics Ltd and Canadian Space Agency. Used with permission.

is 600 kg. Control and monitoring of SPDM components is performed using the same RWS system as the SSRMS (Figure 1.3) or via ground commanding.

**Manipulation operations.** The ISS RWS design enables both single- and multicrew access for manipulator, camera, and support equipment operation. There are normally six crew members onboard the ISS, except for brief crew change-out periods. One of NASA's ground rules for assigning ISS United States Operating Segment crews is that at least three of the crew members should be qualified for SSRMS/SPDM operations. One reason for this rule is that unplanned robotic operations may be required to address ISS system failures. Workstations were also ergonomically designed to accommodate restraints that provide postural stability and comfort for the operator during extended robotic teleoperations, some of which may last for up to 7 hr.

For complex operations, such as the capture of free-flyer spacecraft, two qualified onboard operators are required. A single onboard operator is acceptable for SSRMS operations during generic robotic maneuvers, for payload-handling tasks, or during support of EVAs. Robotic operators are designated as either M1 or M2. M1 refers to the person controlling the SSRMS or initiating automatic sequence motion. The M2 assists with tasks

such as navigating through detailed procedures, communicating with ground controllers or EVA crewmembers, configuring and operating cameras and other sensors, robotic system monitoring, monitoring and/or commanding of free-flyer spacecraft during approach or departure, and maintaining vigilance of clearances from surrounding structures. The role of the M2 helps to reduce the time required to complete complex robotic operations and enhances the crew's overall situation awareness during robotic operations. However, if a second onboard operator is not available, either another onboard crew member who is trained on the operation of the RWS or ground controllers may be used to assist the M1. Sufficient communications coverage with the mission control center in Houston must exist for ground controllers to function as the M2.

Qualified SSRMS/SPDM operators are also designated with one of three proficiency levels: "strong," "good," and "acceptable." These designations are used to determine the level of task complexity that an operator may be assigned to perform. Appropriate tasks for a strong operator include the most complex tasks, such as free-flyer spacecraft track and capture, payload installations and extractions, and robotic support during EVA operations. An operator designated as good would be cleared to perform payload extraction/install only if a precision positioning system were available, such as the force moment sensor. He or she could also be assigned as M2 for complex operations, such as free-flyer grapple/release. An acceptable operator could perform basic tasks, such as single-axis manual maneuvers, and serve as an M2 for any SSRMS task except free-flyer operations. ISS crew assignment ground rules state that at least one crew member will have a qualification level of strong and the other will have a minimum qualification level of good.

**ISS robotics design guidelines.** One key design consideration for ISS robotic workstations was to provide hardware switches for emergency intervention by operators rather than relying solely on software interfaces. It is cumbersome and time-consuming for operators to negotiate through several layers of software to send an emergency stop command during a malfunction of the system. This design also mitigates the risk associated with malfunctions that could render the portable computer system inoperative.

Although other options were evaluated early in the design cycle of the RWS, such as a single 6-DOF controller, two 3-DOF hand controllers were determined to be the preferred design for SSRMS/SPDM robotic control input devices (Stuart et al., 1990; Whitmore, Stealey, & Wilmington, 1991). The principal consideration in this design selection was commonality with both legacy systems, such as the SRMS, and other ISS manipulator systems, such as the Japanese Experiment Module RMS. The use of common hand controller designs reduces operator training, enhances positive habit formation, and reduces the potential for inadvertent or errant commands.

Another area of emphasis in the design of the RWS was graphical user interface (GUI) commonality. Crew members on the ISS represent many nationalities, languages, and cultures, and GUI interfaces, icons, and procedures must be intuitive for all operators. NASA developed standards and guidelines for the design and implementation of displays and graphical products used both by the onboard crew and in ground control centers (ISS Program, 2007, 2008). A specific consideration for teleoperator displays was consistency in the presentation of joints and segment position and attitude information. The standard used is that the joints and major components are arranged in order of their

physical location in the manipulator, starting with the base on the left side of the graphic. The arm booms are further labeled with *Base* and *Tip*, which is particularly important since the SSRMS has the capability to swap base ends during “walking” maneuvers.

Specific display and graphic colors were developed in accordance with industry and international standards (Fowler, 1998). Each color has a specific operational meaning. For example, a red color is used to alert the operator to pay immediate attention to the robot motion to avoid a potentially catastrophic event, and yellow indicates an out-of-limits condition or warrants operator attention to the robot motion to avoid loss of time. However, another design tenet is that colors are not used as the sole means for identification of the status of a component or subsystem. Alternate cues include visual indicators, such as labels, telemetry, or other graphical changes, to acquire the attention of the operator, and audio cues are used as alerts. In some cases, the background color of each robotics system is tinted to differentiate systems that are similar in content, such as the two identical manipulator arms of the SPDM.

The lack of design standards for robotic mechanical interfaces (attachment points, connectors, etc.) on ORUs and payloads has resulted in the development of numerous specialized interfaces and tools to accomplish SPDM manipulation operations. The variety and number of tools required significantly increase both operational complexity and operator training requirements. Not only are grasping interfaces unique, but berthing and alignment hardware used to secure an ORU or a payload to external fixtures on the ISS also varies. Significant time and manpower is spent performing premission planning and analysis for each ORU maintenance or payload operation (Rembala & Ower, 2009). Additionally, operators must train for unique operational strategies and techniques to grasp/release an ORU with the end effector and to align/berth the ORU to the ISS.

Visual cues for insertion alignments, primarily provided by externally mounted video cameras, include intrinsic physical features of the interface tool, the ORU, and the work environment. To achieve proper alignment, the operator manipulates the two 3-DOF hand controllers in translational ( $x, y, z$ ) and rotational (pitch, yaw, roll) axes, causing motion of the end effector and attached ORU/payload with respect to the selected coordinate frame. Visual target and supplemental aids are also used for some insertions requiring precise alignment. Figure 1.6 depicts some of the visual targets used for SPDM operations. Operators spend a significant amount of time training with each of these target schemes to become familiar with interpreting visual alignment cues.

During manual control of SPDM, there is often a lack of kinesthetic sense between the robot and controller. In this case, operators have a tendency to rely more on visual features in the display, such as geometry, texture, and shading, to determine orientation and motion. However, the irregular geometry of externally mounted ISS cameras, combined with the ability of remote operators to control camera orientation (i.e., pan and tilt), can result in display views that are incongruent with the fixed coordinates at the hand controller. This incongruence can lead to cognitive challenges for operators to correctly interpret visual cues, thus increasing the occurrence of display–control misalignments (Chintamani et al., 2011).

When multiple SPDM interface tools are required for a particular task (i.e., due to the lack of standardized mechanical interfaces), the length of time required for SPDM operations is greatly extended. Some complex maintenance tasks involving the removal and

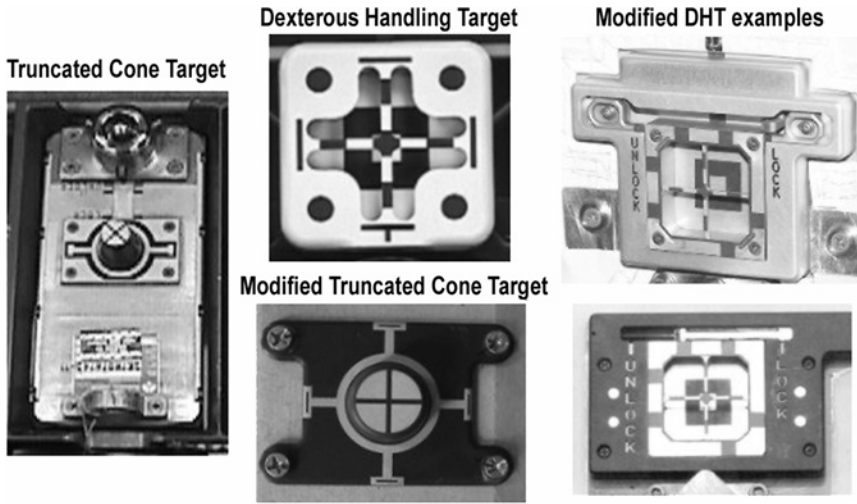

**Figure 1.6.** Visual targets used for Special Purpose Dexterous Manipulator operations. Source: National Aeronautics and Space Administration.

replacement of components located on the exterior of the ISS can result in operations lasting for many hours or, in some cases, over the course of several days. Not only does task complexity lead to protracted task timelines, but it also presents additional operational complexities due to fluctuations in orbital lighting conditions. At an average altitude of 350 km, the ISS orbits Earth approximately every 90 min. This orbit results in exceptionally dynamic lighting conditions, from extreme glare to extreme darkness, which contributes to the complexity of SPDM operations.

Observations during the SPDM checkout in 2010 revealed that variable lighting conditions cause difficulties in viewing the camera overlays that assist the operator when precise alignment is critical, such as grapples a payload or ORU (Ezer, Zumbado, Sándor, & Boyer, 2011). Accurate calibration of these overlays is extremely sensitive to factors such as mechanical interface tolerances, pressure and thermal deformations, and vehicle vibrations. Further, due to the limited field of view of most of the ISS exterior cameras, the overlays can be used only during the final stages of end effector alignment when the target is in the camera's field of view. Additionally, the nonintuitive nature of supplemental exocentric camera views can present challenges for the operator to accurately interpret the distance between objects and robot speed.

Although the original intention was for SPDM to be operated by astronauts on orbit, it was quickly determined that operational timelines far exceed available ISS crew time. As a result, ground control operations were approved and the first full implementation of an ORU removal and replacement by ground controllers occurred in August 2010. Ground control of SPDM is accomplished through manual and supervised control. Commands from the ground to the robot are selected and sent through a multistep process, requiring the detailed operating procedures to be approved in advance of each activity, leaving little flexibility during times of troubleshooting.

The majority of human factors research on space telerobotic operations in support of human-tended missions has focused on single-operator control of manipulators with continuous input devices. However, when ground controllers operate the SSRMS or SPDM, safety policies and operational limitations impose different control strategies and methods. Typically, ground controllers have much lower situation awareness than the onboard crew, which can be attributed to a lack of good, continuous views of the work site and surrounding environment as well as communications issues, such as data latency. Thus, instead of operating the SSRMS/SPDM with continuous input, ground controllers must issue discrete command and control inputs. One safety requirement is that all commands need to be issued in two stages (“arm-fire”). Additionally, whereas there is only one primary operator onboard the ISS required for general SSRMS maneuvers, ground control involves multiple personnel, each with unique roles and responsibilities. For example, to ensure no erroneous commands are sent to the ISS, two ground controllers are required to verify a command before it is uplinked. Thus, teamwork and effective communication are essential for safe ground control operations of the space manipulators (Ezer et al., 2011).

**Key SPDM lessons learned.** Although NASA continues to gain on-orbit experience with the SPDM, several key lessons have already been learned. First, the lack of standardized mechanical interfaces has significantly increased the cost and time associated with tool development, operator training, premission planning, manipulation operations, and analysis. Use of common interfaces or design standards would result in substantial savings. Operator reliance on visual features, combined with the effect of variable and extreme lighting conditions, tends to result in protracted task timelines. Better graphical displays and the use of automated functions could improve operator performance and reduced task times. Reassigning some of the SPDM tasks to the ISS ground control team has also been shown to save significant astronaut time that can otherwise be allocated to science tasks. However, much work remains to be done to develop efficient, effective, and safe ground control strategies, particularly for team-based operations and contingency handling.

## MERs

**System summary.** The MER mission is representative of the use of telerobots to explore space environments where humans cannot yet go. The objective of MER is to use two identical planetary rovers, Spirit and Opportunity, to search for evidence of the past presence of liquid water on Mars. In contrast to SSRMS and SPDM operations, the communications delay between ground control and the MER robots is measured not in seconds but rather in tens of minutes. Since landing on Mars in 2004, Spirit and Opportunity have together traversed over 40 km across the Martian surface and have made hundreds of in situ observations (Bell, 2010). These results were achieved over several thousand surface operation cycles, with high-level autonomy largely limited to autonomous traverse.

**Planetary rover.** The two solar-powered MERs (Figure 1.7) are identical six-wheel-drive, four-wheel-steering rocker-bogie suspension vehicles capable of driving over



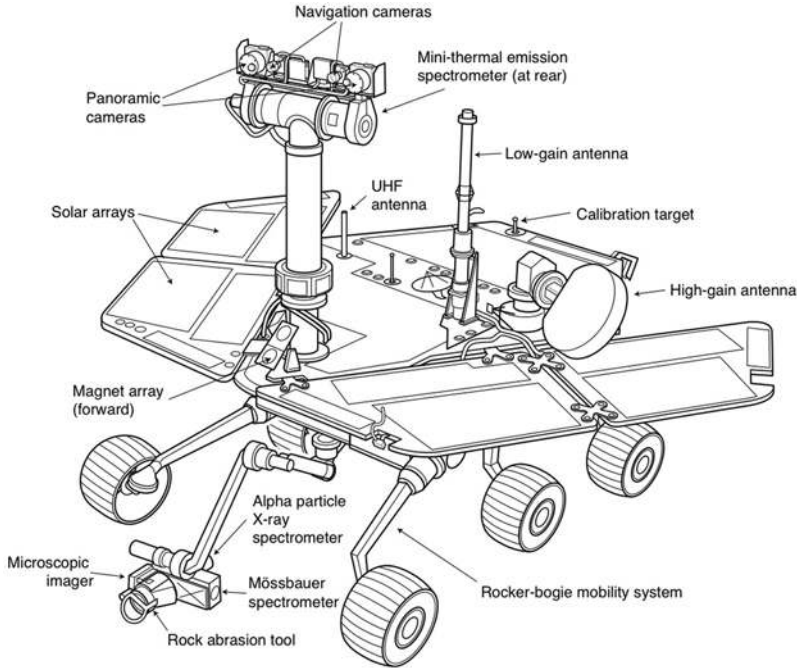

**Figure 1.7.** The Mars Exploration Rover is a solar-powered, six-wheeled planetary rover equipped with numerous science instruments.

Source: National Aeronautics and Space Administration/Jet Propulsion Laboratory–California Institute of Technology.

hazards as tall as the rover's wheels. Remote science instruments include the mast-mounted, multispectral stereo Panoramic Camera and mini Thermal Emission Spectrometer. A 5-DOF robotic arm, known as the instrument deployment device, enables placement of a microscopic imager, Mössbauer spectrometer, Alpha Particle X-Ray Spectrometer, or Rock Abrasion Tool in contact with rock surfaces or regolith (loose material over rock). Additional body-mounted and mast-mounted stereo cameras provide imagery to construct terrain maps for traverse and arm motion planning.

The MERs are capable of both low-level (basic) driving and autonomous traverse. For low-level driving, the vehicle executes a sequence of driving primitives, a combination of arcing motions and turns in place, with no onboard model of the terrain in which the vehicle is moving. For autonomous driving, the vehicle is given a sequence of waypoints in the terrain and navigates itself to those waypoints while avoiding hazards as necessary along the way. To do so, the rover captures stereo imagery periodically during its traverse using its hazard cameras, identifies any mobility hazards from this information, and computes onboard local paths around such hazards on its way to the designated waypoint. Additional onboard flight software detects and prevents any collisions between the instrument deployment device (robotic arm) and itself or other rover hardware.



**Mission operations design.** The design lifetime (primary mission) of each rover on the surface was approximately 90 Martian days, or *sols* (24 hr, 39 min, 35 s per sol). It was expected that soon after this time, dust buildup of the rovers' solar arrays would substantially reduce their energy output, rendering the vehicles inoperable. In addition to this presumed limitation on rover survivability, other key constraints to be managed were vehicle available energy (with dust-free solar arrays generating less than 1,000 W-hr per sol), minimum permitted battery state of charge, and electronics and actuator thermal state.

The primary design drivers for MER operations, however, were related to communication constraints. First, and foremost, the rovers' capabilities and the mission operations strategy needed to accommodate the inherent speed-of-light communications time delay between Earth and Mars (from 6 to 44 min round-trip, depending on relative distance). In addition, continuous communications were not feasible for the mission for a variety of reasons: A link was possible only between Earthrise and Earthset in the rover's sky, the Deep Space Network is an oversubscribed resource servicing spacecraft all over the solar system, and the rovers had insufficient power to transmit for more than a few hours per sol. At best, each rover would be able to transmit a few thousand bps, with total telemetry restricted to about 20 Mb per sol.

These communications constraints precluded the possibility of directly teleoperating the rovers with manual control. Instead, MER required use of stored command sequence execution, as is typically employed for deep-space probes (e.g., Voyager, Galileo, Cassini). However, those missions typically developed and validated command sequences in processes taking weeks—or even months—before uplinking them to the spacecraft. The combination of (presumed) limited rover lifetime and the nondeterminism associated with exploring the natural unstructured Mars surface environment called for a much more rapid, reactive command generation process.

Like most robotic deep-space robotic missions, MER was a science mission, meaning that under nominal conditions (i.e., in the absence of a spacecraft anomaly), every command cycle integrated science and engineering needs. Unlike orbiter and free-flyer missions, which are typically trajectory driven (with the observations that can be made determined by the predetermined path of the vehicle relative to targets of interest), MER was discovery driven, such that future rover activities depended on the results of prior instrument observations and what was seen at the end of each traverse.

**Tactical operations.** Although MER mission operations include several strategic processes (communications planning, resource model updates, multiweek rover activity plans), the bulk of mission resources were dedicated to the time-critical *tactical operations* process. Rather than attempting to mitigate the impacts of communications time delay, this process took advantage of the rovers' inherent inactivity during the Martian night to provide the ground control team with time necessary for command sequence planning. In particular, tactical operations centered on a "tactical timeline," which generated a new command sequence in approximately 18 hr between the Mars afternoon downlink of critical rover telemetry and when the rover "woke up" the next Martian morning.

Since the specific results and success of a sol's execution could not be known in advance, the operations process was designed to respond to the telemetry received at the end of that

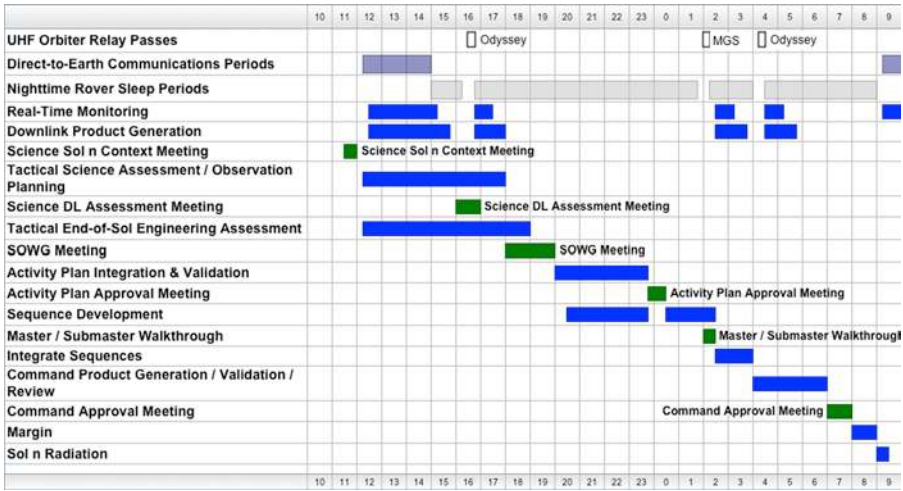

**Figure 1.8.** Mars Exploration Rover tactical operations process as performed during the primary mission phase (adapted from Mishkin, Limonadi, Laubach, & Bass, 2006). The hour labels shown at top and bottom of the chart represent Mars local time at the rover’s landing site. Source: National Aeronautics and Space Administration/Jet Propulsion Laboratory–California Institute of Technology.

execution, derive a science/engineering team consensus defining the next sol’s coordinated use of the instrument suite within available onboard resources, and build the command sequences (typically composed of between 500 and 1,000 commands) to implement that plan on Mars. During the MER primary mission phase (the first 90 sols after landing), the operations teams worked a “Mars-time” schedule, staying synchronized with the rovers’ schedules, which were slaved to the Mars clock. With a Mars day being about 40 min longer than an Earth day, this synchronization required Earthbound operators to migrate their work shifts later by 40 min each day as well.

The tactical process (Figure 1.8) performed the following steps (Mishkin et al., 2006): (a) receipt of downlink, (b) engineering downlink assessment, (c) science downlink assessment and science activity planning, (d) activity plan refinement and validation, (e) activity plan review and approval, (f) command sequence generation, (g) sequence integration and validation, (h) command sequence review, and (i) transmission of commands to the spacecraft.

Upon receipt of critical telemetry (i.e., data required for planning the next sol’s activities) by midafternoon (Mars local time), the rover engineering team assessed the health of the rover’s subsystems and confirmed that the sol’s activities were completed as planned. Rover kinematic state and traverse performance were also evaluated as appropriate. As part of this assessment, the engineering team determined whether any constraints needed to be imposed on the planning cycle for the next or future sols.

In parallel with this assessment, the science team assessed instrument health and results and reviewed imagery from the current rover position. Team members proposed observations (sets of related activities) to be performed in the next sol’s plan. These requests were

defined using a Science Activity Planner tool (Norris, Powell, Vona, Backes, & Wick, 2005). At the Science Operations Working Group (SOWG) meeting, the competing observation requests were reconciled, a rough overall activity plan for the sol was developed, and the overall resources (energy, data volume, duration) required by the plan were modeled. The command sequencing team then assessed the proposed sol plan for feasibility, both from the standpoint of rover capability and from the perspective of the operations team being able to implement and validate the necessary commands in the hours remaining before the approaching uplink deadline.

After the SOWG meeting, activity planning and command sequencing were performed in parallel. With use of the MAPGEN (Bresina, Jonsson, Morris, & Rajan, 2005) activity planning and scheduling software, science and engineering activities were integrated, and the sol activity plan was finalized and validated. High-fidelity resource modeling and flight-rule checks were performed to ensure that the plan did not exceed available rover resources and that there were no conflicts among activities. In addition, activities were deleted (on the basis of priorities from the SOWG) so that the plan was fully compliant with resource constraints. Concurrently, other team members generated command sequences associated with the individual activities in the plan. Although there was some potential that planning effort would go into sequences that would ultimately be dropped from the plan, the risk was considered small compared to the benefit achieved by parallelizing the activity planning and sequencing steps.

Rover motion planning (for both traverse and instrument placement) was performed using the Rover Sequencing and Visualization Program (Hartman, Cooper, Maxwell, Wright, & Yen, 2010), which included the Rover Sequence Editor (RoSE) and HyperDrive. All command sequences, for both rover motion and other activities, were developed using RoSE. HyperDrive was used to visualize rover motions across 3-D terrain along with a graphical representation of terrain traversability based on known vehicle capability and parameter settings. During each tactical operations process, two engineers planned rover motion using these software tools to assess the feasibility of the proposed traverse and in situ science targets, to develop all rover motion command sequences, and to simulate and validate those sequences.

***Refined operations.*** By about 2 months after landing, the original 18-hr duration of the tactical operations process had dropped considerably—to approximately 11 hr. This reduction was achieved by a number of factors, including process automation, increased work proficiency, task streamlining, and the buildup of reusable command sequence libraries (Mishkin & Laubach, 2006). A major reduction in planning time was achieved using the Command and Uplink Generation and Review tool set, which automated much of the integration of command sequences, generation of command products for uplink, and creation of data products for review. These software tools significantly reduced the opportunity for human error during the operations process by eliminating otherwise mundane and repetitive manual tasks.

In addition, it was quickly realized that maintaining a Mars-time operations schedule was not sustainable over the long term due to the impact on the ground team (Bass, 2005; Mirmalek, 2008). Thus, the tactical timeline duration was reduced to enable transition to

a “modified Earth-time” schedule 3 months after the start of rover operations. With this modified schedule, the tactical timeline would start no earlier than 7 a.m., and no later than 1 p.m., Pacific Time. Consequently, several days each month, the tactical process would execute before the results of the prior sol had been received. The Earth-time schedule design traded some reduction in mission science return for an operations process that could be used indefinitely. Other tool and process improvements later provided the capability to plan multiple sols in a single planning cycle, which enabled the transition from 7-days-a-week to 5-days-a-week operations.

As these process changes became routine, the MER operations team size dropped to approximately one third of its original size at landing. Over the ensuing months and years, the MER operations process has continued to evolve and to become more streamlined; however, the essential elements of the process have remained the same (Mishkin & Laubach, 2006).

**Key lessons learned.** Several key lessons have been learned during the first 9 years of the MER mission. First, because the MERs are highly resource constrained, high-fidelity resource modeling of command sequences prior to execution has proven to be absolutely essential. Resource modeling ensures that resource conflicts will not abort the plan, damage the vehicle, or cause mission-ending communications failures. Second, the use of stored command sequences to operate the rover autonomously for a day (or more) at a time has been very effective. In terrestrial applications with no discernible time delay, such an approach might reduce throughput and flexibility. With long time delays, however, this approach increases mission throughput. Third, because MER is discovery driven, the duration of the tactical cycle drives mission return: The shorter the command cycle, the more command opportunities over the life of the mission. Rigidly enforcing the tactical timeline to reconcile conflicting science objectives has been enabling to mission success.

Fourth, although long-distance rover traverse was originally envisioned to be solely reliant on stereo-vision-based autonomous navigation, the extensive time required for onboard processing led to a new, mixed strategy to maximize the distance covered per sol: For the first leg of a traverse, the vehicle would dead reckon a path designated by mission operators using stereo imagery captured from the rover’s initial position, and for the second leg, the vehicle would make full use of its onboard autonomy to cross terrain beyond the limits of traversability data available to the operators. Fifth, as the mission continued far beyond its expected lifetime, eventual overconfidence in autonomous driving resulted in embedding of the vehicle in a sand dune when the properties of the terrain subtly changed (Helmick, Angelova, & Matties, 2009). Once the vehicle was extracted from the treacherous terrain, onboard visual (image-based) odometry was implemented to perform checks to ensure the vehicle would autonomously recognize high-slip conditions before they posed a risk to the mission. Finally, it became clear that the ground control team could effectively sustain a rotating Mars-time schedule only for a limited time. Transition to a modified Earth-time schedule has proven to be sustainable indefinitely, while maintaining an acceptable rate of mission return.

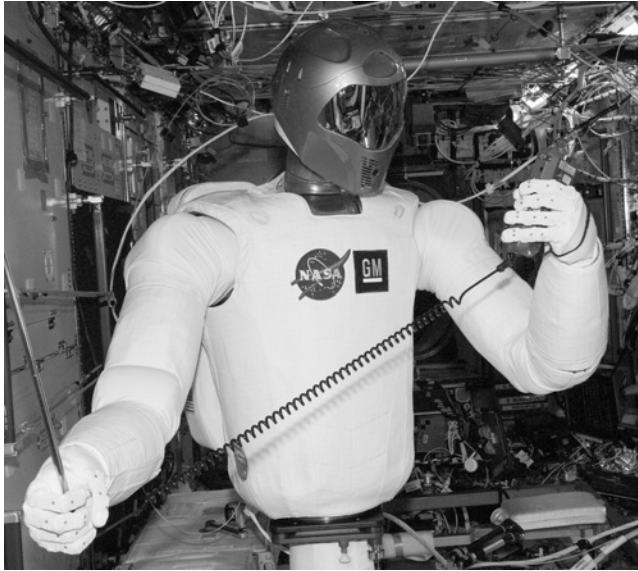

**Figure 1.9.** *Robonaut 2 is the first humanoid robot in space. The robot was delivered to the Space Station in February 2011.*

Source: National Aeronautics and Space Administration (ISS030-E-148257).

## R2

**System summary.** R2, as shown in Figure 1.9, is the first humanoid robot designed specifically for space (Diftler et al., 2011). R2 is the result of a long-term NASA effort to develop robots that can safely operate in human workspaces, can use the same hardware and interfaces (connectors, tools, etc.) as humans, and can serve as an astronaut assistant with similar sizing, strength, and dexterity as a suited astronaut (Bluethmann et al., 2003; Rehnmark, Bluethmann, Rochlis, Huber, & Ambrose, 2003). R2 is envisioned to offload housekeeping and other chores from crew members and to work side by side with them as a teammate in repair and maintenance tasks either during orbital operations or on a terrestrial surface.

R2 consists of a 3-DOF head, 1-DOF torso, two 7-DOF arms, and two 12-DOF hands. The system includes 50 actuators with collocated, low-level joint controllers embedded throughout and integrates built-in computing and power conversion inside its backpack and torso (Diftler et al., 2011). Located in the robot's "head" is a stereo vision camera system with pan and tilt capability to provide visual information for both teleoperators and vision processing.

Other dexterous robots used currently in space applications, such as the SPDM, rely on numerous specialized interfaces designed for robotic compatibility with payloads and ORUs. Only about half of the ORUs on the ISS are specifically designed for robotic servicing, leading NASA to explore alternate ways to offload the sizeable EVA maintenance load from the astronauts (Bridgwater et al., 2006). One significant benefit of humanoid robots

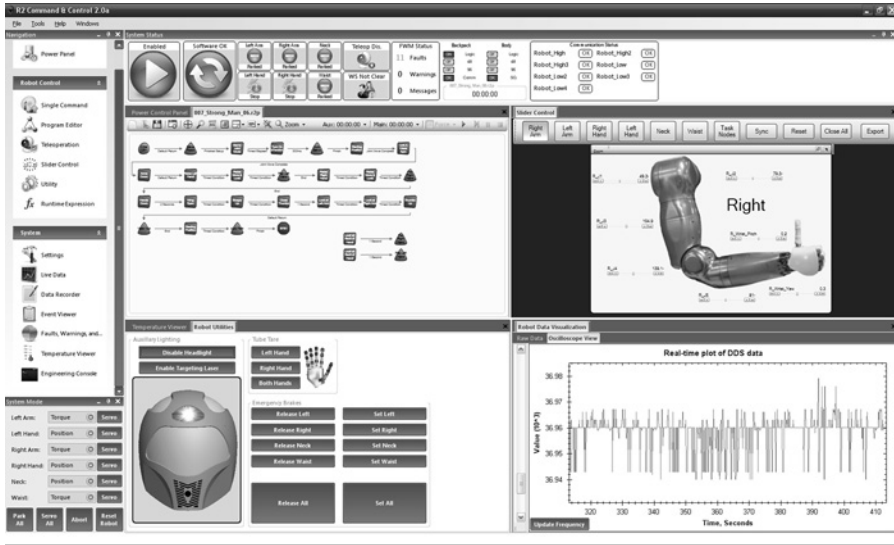

**Figure 1.10.** The Robonaut 2 graphical user interface.  
Source: National Aeronautics and Space Administration.

is the ability for the robots to share the same tool set with human crew members. The design of R2's hands, therefore, accommodates “human-like” dexterous grasps, providing the capability to use the same tools, handholds, and implements as those designed for IVA and EVA astronauts. Decreasing the number of tools required to support nominal and contingency maintenance and repair operations reduces cost, minimizes upmass, and reduces tool stowage volume, which is particularly important to future spacecraft with limited habitable volumes.

R2 was flown to the ISS aboard the STS-133 Space Shuttle flight in February 2011. After R2's arrival and assembly and installation on the ISS, ground controllers and astronauts powered on the robot for the first time in August 2011. The delay between arrival and activation was due to ISS crew scheduling constraints. A series of calibration and validation tests were then performed with R2 over the next several months. These tests included sensor checkout, control gain tuning, initial free-space motions, and the performance of proof-of-concept tasks. Full system operation, with all 42 DOFs active, was established in February 2012. R2 was then used to demonstrate use of a handheld meter to sample ISS airflow, manipulation of common IVA interfaces (switches, buttons, etc.), manipulation of EVA interfaces (e.g., connectors), and performance of a routine ISS in-flight maintenance task (handrail cleaning).

**Operator interfaces.** R2 can be remotely operated by ground controllers at the ISS mission control center in Houston or by astronauts onboard the ISS. The primary operator interface for the robot is the R2 GUI, which permits the user to build up command sequences using a library of control “primitives” (Figure 1.10). The R2 GUI also includes



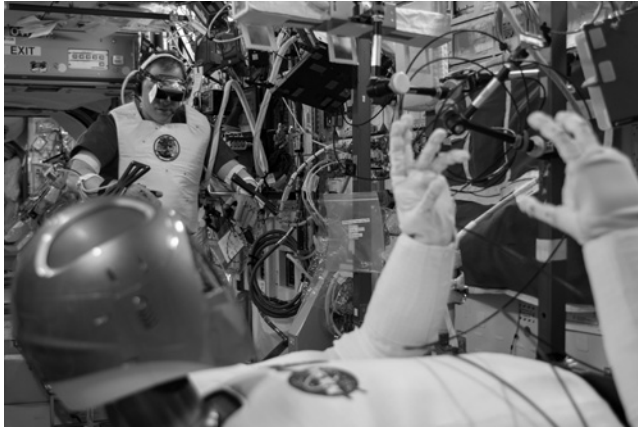

**Figure 1.11.** Astronaut Tom Marshburn remotely operating Robonaut 2 (R2) on the International Space Station using immersive teleoperation gear. The user wears a head-mounted stereo display and instrumented gloves to control R2 head, arm, hand, and body motions. Source: National Aeronautics and Space Administration (ISS035-E-030791).

data displays for monitoring robot health status and collecting data for later analysis. The software and control interfaces are still under development and testing since the Robonaut project is considered a research and development project.

The R2 ground control team consists of three roles: operator, task, and lead. The operator monitors the R2 GUI. The task position monitors the mission and task timelines, monitors procedure steps, and assists the operator during anomalies. The lead position is in charge of the entire activity and handles all real-time communications with the rest of the ISS mission control team. During each R2 activity, the ground controllers also monitor R2's performance by viewing video from fixed cameras in the ISS and from R2's built-in cameras.

A telepresence system can be used to visually immerse the operator in the robot's workspace. The system includes head-mounted virtual reality (VR) display technology to provide a stereo video from the R2 head cameras, gloves that provide hand and finger pose and force sensors, and posture trackers (Figure 1.11). Cartesian commands, measured relative to the operator's coordinate frame, are provided by a body-centric visual tracking system. By mapping human head, arm, hand, and body motions to corresponding R2 robot motions with minimal time delay, astronauts will be able to perform complex, unstructured tasks. Additional features, such as image registration, graphical overlay capabilities, and speech recognition capabilities, facilitate intuitive operation and natural interaction with the robot.

Another highly useful feature is the ability to “freeze/thaw” and “index” the robot's extremities. Freezing allows the operator to relax an extremity without affecting Robonaut posture. Thawing commands the robot to begin receiving control commands and also implies an index of the extremity. Indexing computes the delta difference between the actual robot position and the command position, allowing the operator to be in a different position and orientation relative to the robot's position (Goza, Ambrose, Diftler, & Spain, 2004).



Continuous closed-loop control with even small time delays can create stability problems (Sheridan, 1993), requiring additional strategies (Niemeyer & Slotine, 2004). During space missions, significant latencies in responses to command may be experienced due to distances or delays from satellite transmissions and data-processing systems. Since time delays between the operator and the telerobot can be a dominant factor of instability, significant effort has been invested into extending direct force-feedback methods to time-delayed systems (Hashtrudi-Zaad & Salcudean, 2002; Niculescu, Taoutaou, & Lozano, 2003). Potential strategies for controlling R2 over time delay include a “move-and-wait” technique, bilateral control stabilization, use of predictive displays, and/or supervisory control (Hambuchen et al., 2006).

**Robonaut human–robotic interaction.** Previous experience with dexterous humanoid space robots has been limited to ground testing conducted to explore teaming strategies, operational trade-offs, and collaboration modalities between multiple agents (humans and robots). However, higher-fidelity tests involving anticipated gravitational forces, mobility constraints, communication latencies, and extreme lighting conditions, all of which may affect operator performance, were needed (Rehnmark et al., 2004). Using the ISS as a test bed, researchers can explore operational methods for command and control, including shared control, as well as teaming strategies and collaboration modalities between multiple agents (humans and robots).

During the initial development of the system, teleoperation was used as the primary control mode to experiment with control techniques and assess cost trades for automation. The current Robonaut has some capability to operate autonomously using scripted command sequences or via telepresence control. Telepresence is an immersive form of teleoperation. Using a collection of gear designed primarily for VR, including VR headgear linked to the robot’s stereoscopic cameras, the human operator is essentially immersed in the robot’s environment. Since the operator’s motion is mapped to command the action of Robonaut, telepresence control is extremely intuitive, which reduces operational complexity as well as the training required to operate the system.

A shared-control strategy can also be employed, which divides Cartesian control of Robonaut’s hands between the remote operator and the robot’s onboard controller to minimize operator workload during constrained tasks. Shared control allows the operator to focus on higher-level, goal-oriented behaviors while the robot’s control system compensates for other variables, such as changes in the work environment (Diftler, Oggett, Mehling, & King, 2006). Primitive motions can be used to automate many repetitive physical tasks, subtasks, and mode changes.

**Key lessons learned.** Before the development of R2, experience with dexterous humanoid space robots was limited to ground testing that explored teaming strategies, operational trade-offs, and human–robot collaboration. However, it was clear that higher-fidelity tests involving microgravity, mobility constraints, communication latencies, and extreme lighting conditions, all of which may affect human–robot performance, were needed (Rehnmark et al., 2004). During the past 2 years, testing with R2 on the ISS has begun to explore the impact of these factors. In addition, R2 has demonstrated that a dexterous humanoid robot can successfully use instruments and tools

developed for astronauts (i.e., not specifically tailored for robots) as well as manipulate representative physical (mechanical and electrical) interfaces in an IVA environment. Ground control of R2 has shown that supervisory control (execution of preplanned command sequences) can be effective for remote operations across short time delays. However, as with SPDM ground control, additional research is needed to develop efficient methods for team-based operations required by the ISS and to robustly handle contingencies that cannot be mitigated via advanced planning.

## FUTURE SYSTEMS

The variety of space telerobots is extremely large, especially when considering all systems that might be deployed in space (for use on the ISS and future flight vehicles), to small bodies (e.g., near-Earth asteroids), and on planetary surfaces (the moon, Mars, etc.). Because this range is so broad, no single system configuration or design will serve all future needs (Fong et al., 2012; Gonthier, 2012). Thus, there has been a tremendous research effort in recent years by numerous space agencies to prototype, field-test, and evaluate different telerobots and concepts of operations for future space exploration missions (Fong et al., 2008).

In the following, we present work that is representative of this research effort. In particular, researchers have investigated robotic scouting, robotic follow-up (to human work), crew-centric surface telerobots, and remote operation of field robots. We place emphasis on describing the operational team structures, control modes, and user interfaces that have been studied for these different scenarios. We also note findings that have been reported from this work.

### Robotic Scouting

Robotic scouting, prior to human activity, has the potential to significantly increase scientific and technical return from planetary exploration missions (Hodges & Schmitt, 2010). We define robotic scouting (or “robotic recon”) as operating a planetary rover with ground or IVA astronaut control to scout planned sorties prior to human extravehicular activity (Bualat et al., 2011). Scouting can be: (1) traverse-based (observations along a route); (2) site-based (observations within an area); (3) survey-based (systematic collection of data on transects); or (4) pure reconnaissance.

Although orbital missions (Lunar Reconnaissance Orbiter, Mars Reconnaissance Orbiter, etc.) can produce a wide variety of high-quality maps, they are limited by remote sensing constraints. Instruments carried by planetary rovers can provide complementary observations of the surface and subsurface geology at resolutions and from viewpoints not achievable from orbit. This surface-level data can then be used to improve planning for subsequent human sorties and missions.

As a practical example of how robotic scouting would be extremely useful for future human planetary exploration, we need look no further back than the last human mission to the Moon. During Apollo 17’s second EVA, the crew drove from the lander site to the

South Massif, then worked its way back. At Station 4 (Shorty Crater), astronaut Harrison Schmitt discovered numerous deposits of orange volcanic glass—perhaps the most important discovery of the mission. However, time at the site was severely limited due to available consumables (e.g., oxygen). Had the presence of this pyroclastic material been identified in advance through robotic scouting, the EVA could have been planned to spend more time at Shorty Crater. Or the traverse route could have been changed to visit Shorty Crater first.

Field studies (Bualat et al., 2011; Deans et al., 2009; Fong, Abercromby, et al., 2010) conducted in planetary analog sites have demonstrated that robotic scouting improves human missions in three ways: (a) increases scientific understanding so that better (i.e., more efficient and productive) traverse plans can be produced; (b) reduces operational risk by evaluating routes, terrain hazards, and site accessibility; and (c) improves crew productivity by facilitating situation awareness and understanding of site context.

Robotic scouting for human missions differs from current practice with planetary rovers. Rather than using robots as primary science instruments, scouting relies on robots to collect data that will be used to plan and coordinate subsequent human fieldwork. Consequently, the design of mission operation protocol, ground data systems, and human–robot team coordination is different.

In 2009, NASA conducted a field experiment at Black Point Lava Flow (Arizona) to study robotic scouting (Bualat et al., 2011; Fong, Abercromby, et al., 2010). In this experiment, Fong, Abercromby, et al. (2010) employed a crossover design in which human field geology traverses were planned and executed with, and without, the benefit of robotic scouting. Initially, two “pre-recon” traverse routes were planned using orbital images. A planetary rover equipped with cameras and 3-D lidar was then used to scout the traverses. The scouting data were subsequently used to develop two “post-recon” traverse plans. Finally, the four traverses (pre- and post-recon) were each executed by two astronaut teams using a prototype crew rover and simulated EVA suits.

A central element of the 2009 field experiment was the use of a prototype ground control structure and operations protocol designed for interactive robotic scouting (e.g., Earth-based control of a lunar rover). The ground control was based on operational structures used in both human spaceflight missions (Apollo, Space Shuttle, ISS) and robot missions (e.g., MERs). The structure was split into multiple teams based on work focus: flight control, science operations, and robot operations (Figure 1.12). The flight control team conducted all commanding of the robot using multiple modes: direct teleoperation to supervisory control. The science operations team produced activity plans for the robot based on the objectives of the subsequent human mission, data derived from orbital imaging, and data collected by the robot. The robot operations team responded to robot performance issues and contingencies. Whereas the flight control team addressed rover platform issues on an operational level, the robot operations team resolved issues at an engineering level.

To maximize robot utilization, the ground control team utilized a parallel operations strategy in which it simultaneously performed robot planning, execution, and maintenance (Figure 1.13). This approach was designed to minimize the amount of time the robot was idle. One observation from the experiment was that this control structure was not always practical since the science operations team had to concurrently monitor robot execution, analyze data that had previously been acquired with the robot, and plan future

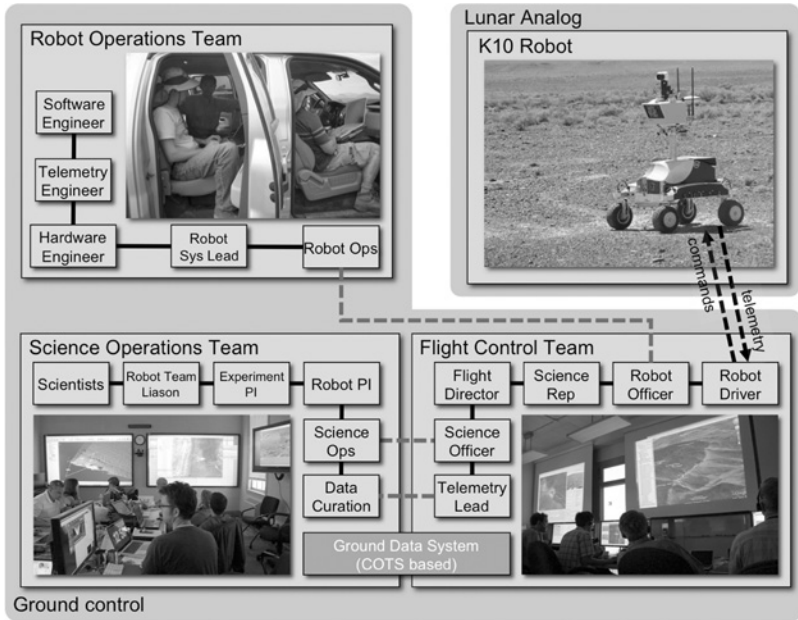

**Figure 1.12.** Prototype ground control structure for robotic scouting (Bualat et al., 2011). Source: National Aeronautics and Space Administration.

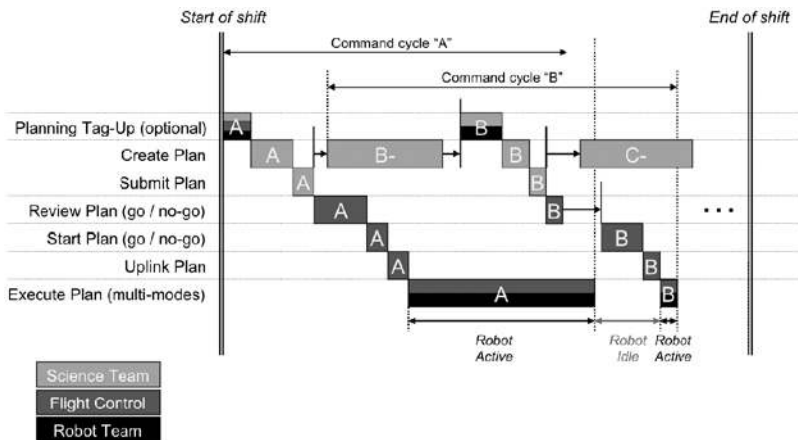

**Figure 1.13.** Tactical operations timeline. Planning, execution, and maintenance are executed in parallel to maximize robot utilization (Bualat et al., 2011). Source: National Aeronautics and Space Administration.

activities. In short, scouting data collection was often constrained by the rate at which science data could be analyzed and synthesized.

Fong, Abercromby, et al. (2010) reported several key findings. First, analysis of robot performance metrics (task times, work efficiency index, and intervention statistics) indicated that strictly minimizing human involvement (i.e., robot commanding time) may not translate into more efficient scouting operations. In fact, it may be more efficient to manually control the robot in difficult terrain than to rely on autonomous navigation. Second, for traverses that emphasized rapid area coverage (e.g., visiting multiple geologic units during a single human sortie), robotic scouting was able to significantly reduce uncertainty and enabled the human mission to be more flexible and adaptive. Finally, the data clearly showed that more study is needed to understand how to optimize science operations during scouting, so that analysis and robot activity planning is not a bottleneck.

## Robotic Follow-Up

A potential use of future space telerobot systems is to perform “follow-up” work after human activity, particularly for planetary exploration missions. In most field geology studies on Earth, for example, explorers often find themselves left with a set of observations they would have liked to make, or samples they would have liked to collect, if only they had been able to stay longer in the field. For planetary field geology, we can imagine mobile robots—perhaps remotely operated vehicles previously used for manned exploration or dedicated planetary rovers—being deployed to perform such follow-up activities. Field studies conducted in planetary analog sites have confirmed several key differences between robotic exploration (e.g., as performed by the MERs) and robotic follow-up. In particular, whereas robot explorers serve as principal science tools, the primary function of robotic follow-up is to augment and complete human fieldwork. This differentiation has significant implications for mission design and science operations.

During 2009-2010, NASA conducted a multimission simulation of robotic follow-up for future lunar exploration. This simulation was performed at the Haughton impact structure (Haughton Crater) on Devon Island, Canada (Deans et al., 2012; Fong, Bualat, et al., 2010). The results from this simulation indicate that robotic follow-up is well suited to (a) testing of hypotheses generated during time-limited human fieldwork and subsequent analysis, (b) refining and augmenting data gathered during crew traverses and EVAs, and (c) rote or long-duration data collection tasks.

In the simulation, a science team first planned human exploration traverses using orbital remote sensing data of the site. Astronauts then carried out the traverses, while identifying sites and tasks for robotic follow-up. After the human mission, the science team analyzed the data and observations collected by the astronauts to develop a robotic mission. Finally, the robotic mission was executed to perform the follow-up work. To ground the fieldwork, the simulation focused on two themes: geologic mapping of the major lithologic units and geophysical survey of the near subsurface using ground-penetrating radar (Figure 1.14).

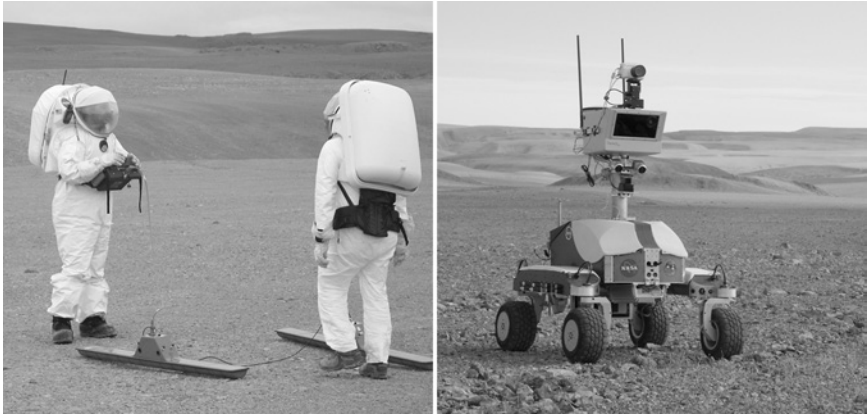

**Figure 1.14.** Simulated exploration missions at the Haughton impact structure. Left: Astronauts manually deploy ground penetrating radar. Right: National Aeronautics and Space Administration K10 planetary rover performs robotic follow-up with ground-penetrating radar (mounted beneath the chassis).

Source: Pascal Lee (left), Matthew Deans (right). Used with permission.

The ground control structure (Deans et al., 2012) employed for the 2010 simulation was partitioned into three subteams, similar to the one used by Bualat et al. (2011). Each team was organized hierarchically and handled three different types of operations: (a) interactive, tactical decision making and robot control; (b) science data analysis and strategic robot activity planning; and (c) robot performance monitoring and engineering support. One unique design feature of the ground control structure was that personnel rotated between the flight control (tactical) and science operations (strategic) teams. This design enabled the structure to be highly responsive and adaptable to contingencies and serendipitous science opportunities.

Lee et al. (2011) described the ground data system that was used for telerobotic science operations. This system included software tools for planning, monitoring, visualizing, documenting, analyzing, and accessing instrument data acquired during telerobot operations. The tools can be broadly grouped into two categories: uplink and downlink. The uplink set is used to create robot activity plans, generate commands, and communicate commands to the robot. The downlink set is used to monitor robot telemetry, downlink instrument data, and process the data.

Fong, Bualat, et al. (2010) reported several key findings from the multimission simulation. First, evidence strongly indicates that robotic follow-up is useful for geologic mapping and geophysical survey. In particular, robotic follow-up provides quantitative data that are complementary and supplemental to astronaut observations. Second, the simulation revealed that consistent localization is needed to coregister data acquired by orbital remote sensing, human surface missions, and robotic follow-up. Although position estimates with limited accuracy can often be rectified through postprocessing, interactive exploration missions will need real-time positioning that can be used by humans and robots alike. Finally, Fong, Bualat, et al. found that orbital remote sensing, human surface





**Figure 1.15.** Artist conception of astronauts remotely operating planetary rovers from orbit (L2 Lagrange point).

Source: National Aeronautics and Space Administration Goddard Space Flight Center.

missions, and robot follow-up missions provide data that can be used in combination to improve the coverage, completeness, and quality of planetary fieldwork.

Deans et al. (2012) note, however, that for robotic follow-up to be effective, there must be good coordination between the work that humans perform and the subsequent work that robots carry out. Specifically, the efficiency, productivity, and benefit of robotic operations are highly coupled to the robot's capabilities. Thus, human mission planning needs to involve consideration of not only what humans will do but also what robots can (and cannot) do to follow up.

## Crew-Centric Surface Telerobots

Numerous study teams have proposed that astronauts should be able to remotely operate surface robots from a flight vehicle (Figure 1.15) during future exploration missions (Augustine et al., 2009; Burns et al., 2012; Carey et al., 2012; Hopkins, 2012; Lester, Hodges, Ower, & Klaus, 2012; Lester & Thronson, 2011; Oleson, Landis, McGuire, & Schmidt, 2011). A variety of science and engineering tasks could be performed in this manner, including sample collection, scouting, site preparation, instrument deployment, and repair/maintenance. This concept of operations may be appropriate for several possible missions:

- L2 lunar far side: Astronauts orbiting the moon (or station-keeping at the L2 Earth-moon Lagrange point, a location where the combined gravity of the Earth and moon allows a spacecraft to maintain a stationary orbit over the lunar far side) could remotely operate a surface robot exploring the lunar far side. Astronauts would take advantage of low-latency (less than 250 ms) and high-availability communications to maximize robot utilization during a short-duration mission.



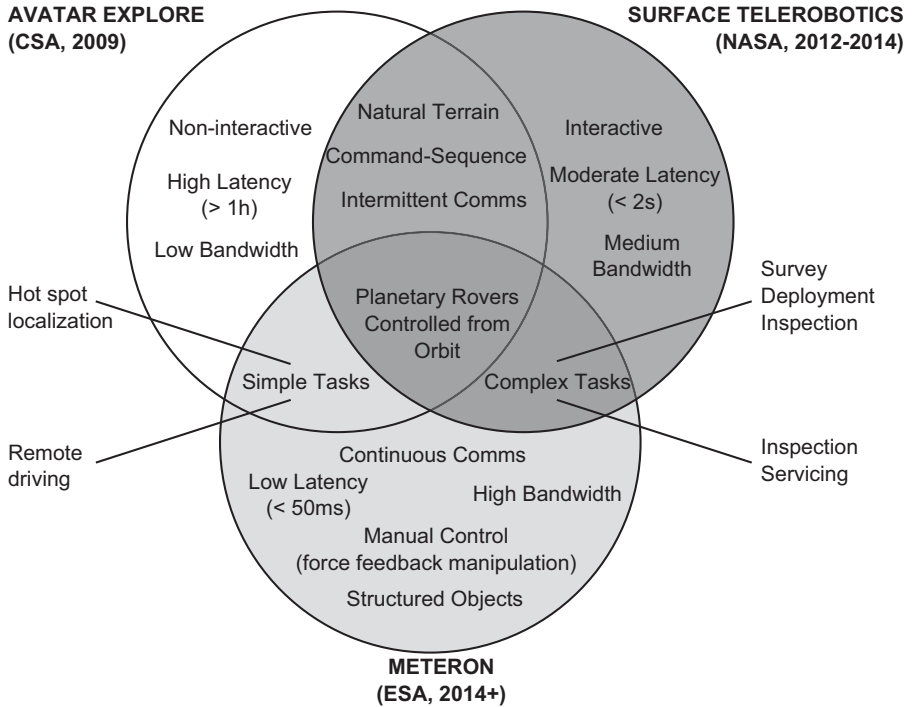

**Figure 1.16.** Research efforts in crew-centric surface telerobotics by the Canadian Space Agency, the European Space Agency, and the National Aeronautics and Space Administration. Source: National Aeronautics and Space Administration.

- NEO: Astronauts approaching, orbiting, or departing an NEO could remotely operate a robot landed on the surface. Astronauts would control the robot from the flight vehicle because the NEO environment (high rotation rate, rapidly varying illumination, etc.) rules out remote operations from Earth.
- Mars orbit: Astronauts in aerostationary orbit around Mars (or landed on Phobos or Deimos [Martian moons]) could remotely operate a surface robot exploring Mars. Astronauts would control the robot from the flight vehicle when circumstances (time-critical activities, contingency handling, etc.) do not permit remote operation from Earth.

From 2009 to 2012, the CSA, the European Space Agency (ESA), and NASA began studying “crew-centric surface telerobots.” This study involves examining a broad and diverse functional space: control mode (direct teleoperation/manual control to supervisory control), communications (latency, bandwidth, availability, etc.), task (complexity, routine vs. novel, etc.), robot motions (mobility and/or manipulation), environment (structured vs. natural terrain), and user interfaces (immersive telepresence, force feedback, 2-D/3-D graphical displays). Figure 1.16 shows how CSA, ESA, and NASA’s research projects address different aspects of remotely operating planetary rovers from orbit.

Dupuis et al. (2010) describe CSA's Avatar-EXPLORE project, which has validated operating concepts for autonomous navigation of a planetary rover under infrequent supervision by an operator. During ISS Expedition 20/21, a Canadian astronaut (Robert Thirsk) remotely operated a planetary rover in CSA's Mars Emulation Terrain to identify thermal anomalies and to navigate the rover to within 1 m of each anomaly. All robot operations were conducted using a noninteractive, supervisory control process, similar to the command sequencing used by current Mars rover missions. With this process, the ISS astronaut received telemetry files from the robot, analyzed the data, generated a command sequence, and prepared a command file. Each command file was downlinked from the ISS to mission control, then transferred to the robot for execution at a later date. After execution of the command file was complete, a rover telemetry file was uplinked to the ISS.

The primary finding from Avatar-EXPLORE was that an astronaut can remotely operate an exploration rover from space. Although the project involved only 3 total hours of crew time and completed only six robot command sequences, the project successfully demonstrated the value of autonomy (including navigation and terrain modeling) for situations in which the robot must operate with infrequent supervision of an operator. Dupuis et al. (2010) report that having the astronaut handle strategic planning while delegating tactical planning/execution to the robot is an effective operational strategy. In addition, it was observed that the astronaut developed trust in the rover's capabilities over time, which meant that it was possible to reduce the amount of data (e.g., terrain information) that had to be transmitted from the robot to the operator for commanding.

Bualat et al. (2012) describe NASA's Surface Telerobotics project, which was designed to obtain baseline engineering data for a crew-centric surface telerobotic system through ISS testing. The project's objectives were to (a) mature technology required for crew control of surface telerobots (specifically, robotic control interfaces for crew), (b) demonstrate that an astronaut can remotely operate a surface robot from inside a flight vehicle to perform exploration work with limited support from ground control, and (c) characterize the concept of operations, system performance, and operator workload for this type of human-robot exploration team.

Surface Telerobotics was a simulation of a future lunar orbital mission concept (Burns et al., 2012) that involves sending a crewed vehicle to the L2 Earth-moon Lagrange point. From L2, an astronaut would remotely operate a robot to perform high-priority surface science work, such as deploying a radio telescope. To study this mission concept, the Surface Telerobotics project carried out four key mission phases: (a) premission planning, (b) site survey, (c) radio telescope deployment, and (d) inspection of the deployed telescope.

Bualat et al. (2013) reported that ISS astronauts performed a total of 10.5 hr of remote rover operations during three Surface Telerobotics test sessions. The astronauts used a combination of manual control (discrete commanding) and supervisory control (command sequencing) to remotely operate the K10 planetary rover in an outdoor test area at the NASA Ames Research Center. In contrast to Avatar-EXPLORE, astronauts controlled and monitored the rover interactively, with only minimal (500 to 750 ms) communications latency and intermittent (preplanned) LOS. Bualat et al. observed that (a) rover autonomy, particularly, hazard detection and safeguarding, greatly enhanced operational efficiency and robot utilization; (b) interactive 3-D visualization of robot state and activity reduced opera-

tor workload and increased situation awareness; and (c) command sequencing with interactive monitoring was a highly effective strategy for crew-centric surface telerobotics.

Carey et al. (2012) describe ESA's proposed Multi-Purpose End-to-End Robotic Operations Network (METERON) project. When METERON is carried out, it will examine real-time teleoperation for performing complex tasks that require fine manipulation. In particular, METERON will employ bilateral, master-slave control with real-time force and 3-D vision feedback. Such control can take place only when a communication channel with sufficiently high bandwidth and low latency is available. METERON is designed as a series of ISS experiments involving a variety of mobile manipulator robots, force-reflection devices (from 2-DOF joystick controls to full-arm exoskeletons), user interface displays (2-D graphical to head-mounted stereo), and point-to-point communications links (from the ISS to multiple ground stations). One of the key objectives of METERON is to demonstrate and validate a wide range of robotic control concepts for "robot-on-ground" and "operator-in-space" mission scenarios.

## Telerobots for Cooperative Planetary Exploration

Numerous field studies have been conducted to examine how humans and robots can collaborate and perform cooperative planetary exploration (Clancey et al., 2005; Francis, Moores, & Osinski, 2012; Ross, Kosmo, & Janoiko, 2012). These studies have made use of analog sites that are similar (in terms of environment, geology, isolation, etc.) to the moon, Mars, and other destinations. For example, the NASA Desert Research and Technology Studies (D-RATS) project has conducted a variety of human-robotic mission simulations with mobile robots, including the EVA Robotic Assistant (ERA), the Science Crewed Operations Utility Testbed (SCOUT), and the Space Exploration Vehicle (SEV). Each of these robots was designed to work in close proximity to humans, function autonomously or be remotely operated, and cover a wide range of collaborative tasks. Ross, Kosmo, and Romig (2012) describe the history of the D-RATS project since 1997.

The ERA mobile robot project investigated assistive scenarios, such as cable deployment, solar panel deployment, and robotic "pack mule" support (Burridge, Graham, Shillcutt, Hirsh, & Kortenkamp, 2003; Shillcutt, Burridge, & Graham, 2002). ERA (Figure 1.17) demonstrated automated astronaut following; was used as a tool, sample, and equipment caddy; and employed a wide range of interfaces, including spoken natural language, space-suit-mounted displays, and gesturing.

Much of the technology developed with ERA was expanded upon for NASA's SCOUT project, which examined how an unpressurized crew rover could function as both crew transport and robotic assistant. The SCOUT (Figure 1.18) was operated in several modes: manual driving, teleoperation, and automated control. Voice and gesture recognition allowed the astronaut to command the robot to follow, stop, take photographs, and so on. In an automated configuration, astronauts could command the rover to travel between waypoints or drive them back to base camp (Hirsh, Graham, & Rochlis, 2006; Rochlis, Delgado, & Graham, 2006). Voice commanding allowed the astronaut to obtain robot status and acquire control authority.

Finally, during 2008 to 2011, D-RATS testing focused on the SEV (Figure 1.19), which was a prototype for a pressurized crew rover that could support two astronauts for 2 weeks



**Figure 1.17.** *The EVA Robotic Assistant working with an astronaut.*

Source: National Aeronautics and Space Administration (JSC2002-E-038915).



**Figure 1.18.** *Science Crewed Operations Utility Testbed rover during analog field testing.*

Source: National Aeronautics and Space Administration (JSC2007-E-049521).

of long-range surface science exploration (Abercromby, Gernhardt, & Litaker, 2012; Garry et al., 2008; Hurtado, Young, Bleacher, Garry, & Rice, 2011). A potential use case included remotely driving the vehicle to the next day's work site while the crew sleeps.

Teleoperation of the SEV was accomplished while the vehicle was unmanned: During crew EVAs, the rovers were remotely driven to explore sites of interest, gather photographs, and ferry tools and equipment. Remote operation was performed in the presence of 2 to 10 s of communication delay using a predictive commanding mode. In this mode, the operator interacted with a graphical simulation, which provided predictions of how the vehicle would respond to driving commands based on robot behavior models (Burridge &



**Figure 1.19.** *The Space Exploration Vehicle is a prototype pressurized crew rover.*  
Source: National Aeronautics and Space Administration.

Hambuchen, 2009; Hambuchen et al., 2012). Commands from the simulation were then queued for execution by the robot.

The field studies that have been conducted to date indicate that human–robot teaming has potential for improving planetary exploration. However, it is clear that more research and testing are required to better understand how to effectively coordinate human and robot activity. In particular, humans and robots must be able to communicate clearly about their goals, abilities, plans, and achievements; collaborate to solve problems, especially when situations exceed autonomous capacities; and interact via multiple modalities (dialogue, gestures, etc.), both locally and remotely (Fong & Nourbakhsh, 2005). Moreover, additional work is needed to develop appropriate metrics for assessing the benefits, limitations, and risks associated with human–robot teaming for planetary exploration.

## EVALUATION

Over the past decade, space telerobots have become increasingly more complex and integrated with human operators. Consequently, there is an increasing need for diagnostic methods and metrics to aid in system evaluation. These data are needed to measure how efficiently and effectively human and space robots collaborate, including measurement of team performance and the probability of mission success. In the following, we briefly describe some of the methods and metrics that are being applied to space telerobotic systems.

### Assessment Methods

In contrast to terrestrial systems, space telerobotics presents several unique challenges to performing assessments. First and foremost, the space environment is difficult to replicate. Although laboratory simulations and analog sites can provide high fidelity in many

aspects, it is extremely difficult (if not impossible) to fully duplicate all environmental conditions (microgravity, planetary surface characteristics, etc.). This difficulty adds an element of variability and reduces the accuracy of testing. Second, the user population is very small in number (i.e., robot ground controllers and astronauts in space), which makes it difficult to acquire statistically significant data. Finally, space telerobots tend to be costly-to-build, costly-to-operate, one-of-a-kind systems, which makes testing expensive, time limited, and highly constrained.

As in other domains, assessment of space telerobots requires a systematic approach for the analysis, understanding, development, and improvement of human–robot interactions. Both subjective and objective metrics can be employed to evaluate such interactions (Steinfeld et al., 2006). However, given the limitations previously mentioned, it is important to use multiple methods and techniques to obtain convergent validity. Self-report measures of workload, for example, can be combined with behavioral measures of task performance. It is also preferable to perform assessment studies throughout the life cycle of a system, making use of analysis, simulation, prototyping, and experimentation.

Integrated human–robot test beds have been used to assess the performance of specific space telerobots against representative tasks and criteria. Many of these test beds simulate the space environment in one or more dimensions, especially in terms of data communications (bandwidth, latency, availability), microgravity (via gravity offset or neutral buoyancy), and work site illumination. For example, numerous test beds have been developed to evaluate telerobotic methods for satellite servicing (Artigas, Kremer, Preusche, & Hirzinger, 2006; Hayati, Lee, Tso, Backes, & Lloyd, 2002; Piedboeuf & Dupuis, 2001; Uchiyama, Konno, Uchiyama, & Kanda, 2002).

As an alternative to using physical robots in experimental research, simulation has also been extensively employed. For example, Lamb and Owen (2005) evaluated performance in a teleoperation task using a VR simulation of the SSRMS. The virtual model included a full-scale 3-D exterior view of the shuttle, payload bay, robot arm, payload, and backdrop. By using a virtual robot, they were able to manipulate control interface conditions that would have been unachievable if they had been using the physical robot.

## Task Performance

At first thought, identifying task performance metrics for space telerobotics would not appear to be a difficult problem. Given the critical nature of most tasks in space, the overarching consideration would be whether (or not) the task was successfully completed. A secondary consideration would then be time on task: Time becomes critical when the controlling human is in space (e.g., in a flight vehicle), when the robot is teaming with humans in EVA, or when mission constraints require high-tempo operations.

In general, however, it is unlikely that a single metric will subsume all other possible metrics. Even parameters with apparently widespread consensus on their meaning, such as “productivity,” can be difficult to implement and apply in real-world cases. For example, measurements of productivity in EVA/robotic collaborative structural assembly yielded a number of possible productivity measures, without a single definition that evokes an accurate picture of performance under all conditions (Akin, 1986; Bowden & Akin, 1979). Thus, a typical set of metrics focusing on task performance might include a range of topics,



including productivity, effectiveness, reliability, risk to humans, resource utilization, and so on (Steinfeld et al., 2006).

A study by Singer (2012) on optimizing human and space robot task performance focused on 15 basic metrics, which included “EVA time,” “human wait time for robots,” and “robot wait time for humans.” Schreckenghost, Milam, and Fong (2010) developed a set of real-time metrics for semiautonomous telerobotic rovers, including task times (driving time, instrument run time, etc.), operations time (autonomous, manual, scheduled, and unscheduled), team productivity, and task success. Shaw, Saleh, and Hoffman (2007) propose five metrics for evaluating the performance of human–robot systems for space exploration.

## Operator Workload

Operator workload is a key metric for assessing space telerobots. In particular, given the difficulties associated with performing manual control in space (Jones & Fiedler, 2010), and the safety-critical nature of most tasks, it is critically important to minimize workload so that errors due to fatigue, inattention, and so on can be avoided. Traditionally, workload is associated with operator(s) who directly command a robot via direct teleoperation (manual control), supervisory control, or directed autonomy (Kaber, Onal, & Endsley, 2000). However, workload can equally well pertain to human(s) collaborating with robots in the field, for example, jointly performing geological exploration on a planetary surface.

The most commonly used tests of operator workload for space telerobotics are the Cooper-Harper rating scale (Cooper & Harper, 1969) and the NASA Task Load Index (NASA-TLX; Hart & Staveland, 1988). The Cooper-Harper rating was originally developed to rate handling qualities of experimental aircraft; it has since been modified to generally describe operator performance for human-in-the-loop control. Variations in Cooper-Harper ratings for space telerobotic control can vary considerably on the basis of individual operator reactions. The NASA-TLX was developed to obtain numerical operator feedback on the required workload for a test task based on six (presumably uncoupled) criteria. Usage of the NASA-TLX data may maintain six separate metrics, sum ratings into a single metric, or use pairwise comparisons.

Both the Cooper-Harper and NASA-TLX scales are posttest subjective evaluations on the part of the test subjects. Intrinsically, it ought to be both possible and desirable to extract workload data during testing and thereby eliminate the subjective nature of these protocols. Although techniques that measure residual capacity (e.g., secondary task assessment) or that collect physiological data (heart rate, respiration rate, etc.) can be employed, their usefulness is limited for space telerobotics. In particular, given the small user populations (e.g., astronauts in space) and limited time for experimentation (i.e., due to mission operations constraints), it has proven to be difficult to collect statistically relevant data and to establish reliable correlations between these secondary and physiological measures and workload.

## CONCLUSION

Space telerobots are already serving a variety of purposes, from augmenting crew activities for manned missions to enabling a virtual human presence in deep space. Future space

exploration missions will present significant challenges for telerobotic systems, as human–robot teams must perform work independently and effectively, with support from Earth-based mission control that is remote in both distance and time.

To make future space telerobots as capable and productive as possible, numerous human–robot interaction challenges must be addressed. In particular, we contend that humans and robots must be able (a) to communicate clearly about their goals, abilities, plans, and achievements; (b) to collaborate to solve problems, especially when situations exceed autonomous capabilities; and (c) to interact via multiple modalities (dialogue, gestures, etc.), both locally and remotely.

Moreover, we need to develop safe human–robotic interaction in the presence of multiple control loops that may span a wide range of time delay regimes. A space telerobot may be controlled by an astronaut local to the robot work site, by nearby crew members, or by operators on Earth, with progressive reductions in situation awareness and response time. Different time delay regimes also require distinct levels of control, and increasing sophistication of local sensor-based control, to prevent damage to crew or the system as operators become increasingly remote.

In addition, future exploration missions will require human–robot collaboration across multiple spatial ranges, from shoulder-to-shoulder (e.g., human and robot in a shared space) to line-of-sight (human in habitat, robot outside) to over-the-horizon (human in habitat, robot far away) to interplanetary (human at ground control, robot on planetary surface) interaction. Although a great many telerobotic systems have been developed during the past 50 years, none currently supports multiple spatial ranges; that is, all existing systems are optimized for application-specific spatial ranges. The challenge, therefore, is to develop techniques that support human–robot collaboration over a wide range of distances and allow humans and robots to boldly explore farther and farther from Earth.

## ABBREVIATIONS AND ACRONYMS

AEGIS	Automated Exploration for Gathering Increased Science
bps	Bits per second
CSA	Canadian Space Agency
DOF	Degrees of freedom
D-RATS	Desert Research and Technology Studies
ERA	EVA Robotic Assistant
ESA	European Space Agency
EVA	Extravehicular activity
GUI	Graphical user interface
ISS	International Space Station
IVA	Intravehicular activity
LEO	Low Earth orbit
LOS	Loss of signal
Mbps	Megabits per second
METERON	Multipurpose End-to-End Robotic Operations Network
MER	Mars Exploration Rover
Mb	Megabit
NASA	National Aeronautics and Space Administration
NEO	Near-Earth object

ORU	Orbital Replacement Unit
RoSE	Rover Sequence Editor
RWS	Robotic workstation
SCOUT	Science Crewed Operations Utility Testbed
SOWG	Software Operations Working Group
SPDM	Special Purpose Dexterous Manipulator (Dextre)
SRMS	Shuttle Remote Manipulator System (Canadarm)
SSRMS	Space Station Remote Manipulator System (Canadarm 2)
TLX	Task Load Index

## REFERENCES

- Abercromby, A., Gernhardt, M., & Litaker, H. (2012). *Desert Research and Technology Studies (DRATS) 2009: A 14-day evaluation of the Space Exploration Vehicle prototype in a lunar analog environment* (NASA Tech. Rep. TP-2012-217360). Washington, DC: National Aeronautics and Space Administration.
- Akin, D. (1986). Quantifying performance in space operations. In *XXXVII Congress of the International Astronautical Federation* (IAF 86-24). Paris, France: International Astronautical Federation.
- Ambrose, R., Wilco, B., Reed, B., Matthies, L., Lavery, D., & Korsmeyer, D. (2012). *Robotics, telerobotics, and autonomous systems roadmap (April 2012)*. Washington, DC: National Aeronautics and Space Administration.
- Artigas, J., Kremer, P., Preusche, C., & Hirzinger, G. (2006, October). *Testbed for telepresent on-orbit satellite servicing. Paper presented at the Second International Workshop on Human-Centered Robotics Systems*, Munich, Germany.
- Augustine, N., Austin, W., Chyba, C., Kennel, C., Bejmuk, B., Crawley, E., . . . Ride, S. (2009). *Seeking a human spaceflight program worthy of a great nation*. Review of U.S. Human Spaceflight Plans Committee. Washington, DC: National Aeronautics and Space Administration.
- Aziz, S. (2010). Lessons learned from the STS-120/ISS 10A robotics operations. *Acta Astronautica*, 66, 157–165.
- Bass, D. (2005). Choosing Mars time: Analysis of the Mars exploration rover experience. In *Proceedings of the IEEE Aerospace Conference* (pp. 4174–4185). New York, NY: IEEE.
- Bell, J. (2010). Seven years on Mars: Adventure, adversity, and achievements with the NASA Mars Exploration Rovers Spirit and Opportunity. In *Proceedings of the American Geophysical Union Fall Meeting* (p. 10). Washington, DC: American Geophysical Union.
- Bluemhann, W., Ambrose, R., Diftler, M., Askev, S., Huber, E., Goza, M., . . . Magruder, D. (2003). Robonaut: A robot designed to work with humans in space. *Autonomous Robots*, 14, 179–197.
- Bowden, M., & Akin, D. (1979). Underwater simulation of human dynamics and productivities in extra-vehicular assembly. In *Proceedings of the XXVIII Congress of the International Astronautical Federation* (IAF 79-109). Paris, France: International Astronautical Federation.
- Bresina, J., Jonsson, A., Morris, P., & Rajan, K. (2005). Activity planning for the Mars Exploration Rovers. In *Proceedings of the International Conference on Automated Planning and Scheduling* (pp. 40–49). Palo Alto, CA: Association for the Advancement of Artificial Intelligence.
- Bridgwater, L., Ambrose, R., Diftler, M., Valvo, M., Radford, N., Goza, M., & Strawser, P. (2006). Symbiotic robots for space based construction and maintenance. In *AIAA Space 2006 Conference and Exposition* (pp. 1–7). Reston, VA: American Institute of Aeronautics and Astronautics.
- Bualat, M., Abercromby, A., Allan, M., Bouyssounouse, X., Deans, M., Fong, T., . . . Utz, H. (2011). Robotic recon for human exploration: Method, assessment, and lessons learned. In W. Garry, & J. Bleacher (Eds.), *Analogs for planetary exploration* (Special Paper 483, pp. 117–135). Boulder, CO: Geologic Society of America.
- Bualat, M., Deans, M., Fong, T., Provencher, C., Schreckenghost, D., & Smith, E. (2012). ISS crew control of surface telerobotics. In *IAF/AIAA Global Space Exploration Conference* (GLEXP-2012.01.2.712188). Reston, VA: American Institute of Aeronautics and Astronautics.
- Bualat, M., Fong, T., Allan, M., Bouyssounouse, X., Cohen, T., Fluckiger, L., . . . Wheeler, D. (2013). Surface telerobotics: Development and testing of a crew controlled planetary rover system. In *AIAA Space 2013*

- Conference and Exposition* (AIAA 2013-5475, pp. 1–10). Reston, VA: American Institute of Aeronautics and Astronautics.
- Burns, J., Kring, D., Norris, S., Hopkins, J., Lazio, J., & Kasper, J. (2012). A lunar L2-farside exploration and science mission concept with the Orion multi-purpose crew vehicle and a teleoperated lander/rover. In *IAF/AIAA Global Space Exploration Conference* (GLEX-2012.04.2.312193). Reston, VA: American Institute of Aeronautics and Astronautics.
- Burridge, R., Graham, J., Shillcutt, K., Hirsh, R., & Kortenkamp, D. (2003, May). *Experiments with an EVA assistant robot. Paper presented at the International Symposium on Artificial Intelligence, Robotics, and Automation in Space*, Nara, Japan.
- Burridge, R., & Hambuchen, K. (2009). Using prediction to enhance remote robot supervision across time delay. In *Proceedings of the IEEE/RSJ International Conference on Intelligent Robots and Systems* (pp. 5628–5634). New York, NY: IEEE.
- Carey, W., Schoonejans, P., Hufenbach, B., Nergaard, K., Bosquillon de Frescheville, F., Grenouilleau, J., & Schiele, A. (2012). METERON: A mission concept proposal for preparation of human-robotic exploration. In *1st IAF/AIAA Global Space Exploration Conference* (GLEX-2012.01.2.6.12697). Reston, VA: American Institute of Aeronautics and Astronautics.
- Castano, R., Estlin, T., Anderson, R., Gaines, D., & Castano, A. (2007). OASIS: Onboard Autonomous Science Investigation System for opportunistic rover science. *Journal of Field Robotics*, 24, 379–397.
- Chintamani, K., Cao, A., Ellis, R. D., & Pandya, A. K. (2010). Improved tele-manipulator navigation during display-control misalignments using augmented reality cues. *IEEE Transactions on Systems, Man and Cybernetics, Part A*, 40, 29–39.
- Chintamani, K., Cao, A., Ellis, R., Tan, C., & Pandya, A. (2011). An analysis of teleoperator performance in conditions of display-control misalignments with and without movement cues. *Journal of Cognitive Engineering and Decision Making*, 5, 139–155.
- Clancey, W., Sierhuis, M., Alena, R., Berrios, D., Dowding, J., Graham, J., . . . Rupert, S. (2005). Automating CapCom using mobile agents and robotic assistants. In *AIAA First Space Exploration Conference: Continuing the Voyage of Discovery* (AIAA 2005-2659, pp. 1–40). Reston, VA: American Institute of Aeronautics and Astronautics.
- Cooper, G., & Harper, Jr., R. (1969). *The use of pilot rating in the evaluation of aircraft handling qualities* (NASA TN D-5153). Washington, DC: National Aeronautics and Space Administration.
- Deans, M., Fong, T., Allan, M., Bouyssounouse, X., Bualat, M., Flueckiger, & . . . Utz, H. (2009). Robotic scouting for human exploration. In *AIAA Space 2009 Conference and Exposition* (AIAA-2009-6781, pp. 1–15). Reston, VA: American Institute of Aeronautics and Astronautics.
- Deans, M., Fong, T., Bualat, M., Heggy, E., Helper, M., Hodges, K., . . . Zacny, K. (2012). Using robots before and after humans to improve space exploration. In *IAF/AIAA Global Space Exploration Conference* (GLEX-2012.04.1.512344). Reston, VA: American Institute of Aeronautics and Astronautics.
- Diftler, M., Mehling, J., Abdallah, M., Radford, N., Bridgwater, L., Sanders, A., . . . Ambrose, R. (2011). Robonaut 2: The first humanoid in space. In *Proceedings of the IEEE International Conference on Robotics and Automation* (pp. 2178–2183). New York, NY: IEEE.
- Diftler, M., Oggett, W., Mehling, J., & King, B. (2006). Reconfiguration of EVA modular truss assemblies using an anthropomorphic robot. In *Proceedings of the Space Technologies and Applications International Forum* (p. 992). Albuquerque, NM: AIP.
- Dupuis, E., Langlois, P., Bedwani, J.-L., Gingras, D., Salerno, A., Allard, P., . . . Lamarche, T. (2010, August/September). The Avatar-EXPLORE experiments: Results and lessons learned. *Paper presented at the International Symposium on Artificial Intelligence, Robotics, and Automation in Space*, Sapporo, Japan.
- Estlin, T., Bornstein, B., Gaines, D., Anderson, R., Thompson, D., Burl, M., . . . Judd, M. (2012). AEGIS automated science targeting for the MER Opportunity Rover. *ACM Transactions on Intelligent Systems and Technology*, 3(3), 50.
- Ezer, N., Zumbado, J. R., Sandor, A., & Boyer, J. (2011). Development of methodologies, metrics, and tools for investigating human–robot interaction in space robotics. In *Proceedings of the Fourth IEEE International Conference on Space Mission Challenges for Information Technology*. New York, NY: IEEE.
- Ferketic, J., Goldblatt, L., Hodgson, E., Murray, S., Wichowski, R., Bradley, A., . . . Stiles, R. (2006a). Toward human–robot interface standards I: Use of standardization and intelligent subsystems for advancing

- human–robotic competency in space exploration. In *Proceedings of the SAE 36th International Conference on Environmental Systems* (SAE 2006-01-2019). Norfolk, VA: SAE.
- Ferketic, J., Goldblatt, L., Hodgson, E., Murray, S., Wichowski, R., Bradley, A., . . . Erkorkmaz, C. (2006b). Toward human–robot interface standards II: A closer examination of common elements in human-robot interactions across the space enterprise. In *Proceedings of the 2006 AIAA Space Conference* (AIAA-2006-7388). Reston, VA: American Institute of Aeronautics and Astronautics.
- Fong, T., Abercromby, A., Bualat, M., Deans, M., Hodges, K., Hurtado, J., Jr., . . . Schreckenghost, D. (2010). Assessment of robotic recon for human exploration of the Moon. *Acta Astronautica*, 67, 1176–1188.
- Fong, T., Bualat, M., Deans, M., Adams, B., Allan, M., Altobelli, M., . . . Young, K. (2010). Robotic follow-up for human exploration. In *Proceedings of the 2010 AIAA Space Conference* (AIAA-2010-8605). Reston, VA: American Institute of Aeronautics and Astronautics.
- Fong, T., Bualat, M., Deans, M., Allan, M., Bouyssounouse, X., Broton, M., . . . Utz, H. (2008). Field testing of utility robots for lunar surface operations. In *Proceedings of the 2008 AIAA Space Conference* (AIAA-2008-7886). Reston, VA: American Institute of Aeronautics and Astronautics.
- Fong, T., & Nourbakhsh, I. (2005). Interaction challenges in human–robot space exploration. *ACM Interactions*, 12(2), 42–45.
- Fong, T., Nourbakhsh, I., Kunz, C., Fluckiger, L., Schreiner, J., Ambrose, R., . . . Scholtz, J. (2005). The Peer-to-Peer Human–Robot Interaction project. In *Proceedings of the 2005 AIAA Space Conference* (AIAA-2005-6750). Reston, VA: American Institute of Aeronautics and Astronautics.
- Fong, T., Provencher, C., Micire, M., Diftler, M., Berka, R., Bluethmann, B., Mittman, D. (2012, March). *The Human Exploration Telerobotics project: Objectives, approach, and testing. Paper presented at the IEEE Aerospace Conference*, Big Sky, MT.
- Fowler, S. (1998). *GUI design handbook*. New York, NY: McGraw-Hill.
- Francis, R., Moores, J., & Osinski, G. (2012). A mission control architecture for joint human and robotic lunar exploration missions, as tested in terrestrial analogue missions. In *Proceedings of the IAF/AIAA Global Space Exploration Conference* (GLEX-2012.04.1.612294). Reston, VA: American Institute of Aeronautics and Astronautics.
- Garry, W., & Bleacher, J. (Eds.). (2011). *Analogs for planetary exploration* (Special Paper 483). Boulder, CO: Geological Society of America.
- Garry, W., Hörz, F., Lofgren, G., Kring, D., Chapman, M., Eppler, D., . . . Walheim, R. (2008). Science operations for the 2008 NASA lunar analog field test at Black Point lava flow, Arizona. In *Proceedings of the 40th Lunar and Planetary Science Conference*. The Woodlands, TX: LPSC.
- Gonthier, Y., Ambrose, R., Jeffries, S., Robins, A., Schultz, J., & Ueno, H. (2012). A human–robotic partnership assessment for the global exploration strategy. In *Proceedings of the IAF/AIAA Global Space Exploration Conference* (GLEX-2012.D1.2.812672). Reston, VA: American Institute of Aeronautics and Astronautics.
- Goza, M., Ambrose, R., Diftler, M., & Spain, I. (2004). Telepresence control of the NASA/DARPA Robonaut on a mobility platform. In *Proceedings of the Conference on Human Factors in Computing Systems* (pp. 623–629). New York, NY: ACM.
- Grotzinger, J., Crisp, J., Vasavada, A., Anderson, R., Baker, C., Barry, R., . . . Wiens, R. (2012). Mars Science Laboratory mission and science investigation. *Space Science Reviews*, 170, 5–56.
- Gugerty, L., & Brooks, J. (2001). Seeing where you are heading: Integrating environmental and egocentric reference frames in cardinal direction judgments. *Journal of Experimental Psychology: Applied*, 7, 251–266.
- Gugerty, L., & Brooks, J. (2004). Reference-frame misalignment and cardinal direction judgments: Group differences and strategies. *Journal of Experimental Psychology: Applied*, 10, 75–88.
- Hambuchen, K., Bluethmann, W., Goza, M., Ambrose, R., Rabe, K., & Allan, M. (2006). Supervising remote humanoids across intermediate time delay. In *Proceedings of the IEEE-RAS International Conference on Humanoid Robots* (pp. 246–251). New York, NY: IEEE.
- Hambuchen, K., Burrige, R., Ambrose, R., Bluethmann, W., Diftler, M., & Radford, N. (2012). Forming human-robot teams across time and space. In *Proceedings of the IAF/AIAA Global Space Exploration Conference* (GLEX-2012.04.2.5). Reston, VA: American Institute of Aeronautics and Astronautics.
- Hart, S., & Staveland, L. (1988). Development of NASA-TLX (Task Load Index): Results of empirical and theoretical research. In P. Hancock, & N. Meshkati (Eds.), *Human mental workload* (pp. 139–183). New York, NY: Elsevier.

- Hartman, F., Cooper, B., Maxwell, S., Wright, J., & Yen, J. (2010). A commanding and visualization software suite for controlling the Mars rovers and other planetary robots. *Journal of Advanced Computational Intelligence and Intelligent Informatics*, 14, 4–12.
- Hashtrudi-Zaad, K., & Salcudean, S. E. (2002). Transparency in time-delayed systems and the effect of local force feedback for transparent teleoperation. *IEEE Transactions on Robotics and Automation*, 18, 108–114.
- Hayati, S., Lee, T., Tso, K., Backes, P., & Lloyd, J. (2002). A testbed for a unified teleoperated-autonomous dual-arm robotic system. In *Proceedings of the IEEE International Conference on Robotics and Automation* (pp. 1090–1095). New York, NY: IEEE.
- Helmick, D., Angelova, A., & Matthies, L. (2009). Terrain adaptive navigation for planetary rovers. *Journal of Field Robotics*, 26(4), 391–410.
- Hirsh, R., Graham, J., & Rochlis, J. (2006). Human assistant planetary exploration robots. In *Proceedings of the Earth and Space* (pp. 1–8). Houston, TX: ASCE.
- Hirzinger, G., Brunner, B., Dietrich, J., & Heindl, J. (1994). ROTEX: The first remotely controlled robot in space. In *Proceedings of the IEEE International Conference on Robotics and Automation* (pp. 2604–2611). New York, NY: IEEE.
- Hodges, K., & Schmitt, H. (2011). A new paradigm for advanced planetary analog exploration exercises on Earth. In W. Garry, & J. Bleacher (Eds.), *Analog for planetary exploration* (Special Paper 483, pp. 17–31). Boulder, CO: Geologic Society of America.
- Hopkins, J. (2012). Early telerobotic exploration of the lunar far side using Orion spacecraft at Earth-Moon L2. In *Proceedings of the IAF/AIAA Global Space Exploration Conference* (GLEX-2012.02.3.212595). Reston, VA: American Institute of Aeronautics and Astronautics.
- Hunter, D., Darlington, T., Krukewich, K., & Laurenzio, D. (1993, October). *Design and operation of the Special Purpose Dexterous Manipulator (SPDM): Advancing the state of the art in space manipulator systems. Paper presented at the 44th Congress of the International Astronautical Federation*, Graz, Austria.
- Hurtado, J., Jr., Young, K., Bleacher, J., Garry, W., & Rice, J., Jr. (2011). Field geologic observation and sample collection strategies for planetary surface exploration: Insights from the 2010 Desert RATS geologist crewmembers. *Acta Astronautica*, 90, 344–355.
- ISS Program. (1991). *Hand controller commonality test report* (JSC 32125, Vols. 1–5). Houston, TX: National Aeronautics and Space Administration.
- ISS Program. (2007). *Software requirements specification for Mobile Servicing Systems (MSS) graphical user interface (GUI): Vol. 3. Special Purpose Dexterous Manipulator (SPDM)* (SSP 50337-03, Rev B). Houston, TX: National Aeronautics and Space Administration.
- ISS Program. (2008). *Display and graphics commonality standard* (SSP 50313, Rev D). Houston, TX: National Aeronautics and Space Administration.
- Jones, P., & Fiedler, E. (2010). Human performance in space. *Reviews of Human Factors and Ergonomics*, 6, 172–197.
- Kaber, D. B., Onal, E., & Endsley, M. R. (2000). Design of automation for telerobots and the effect on performance, operator situation awareness and subjective workload. *Human Factors and Ergonomics in Manufacturing*, 10, 409–430.
- Kermurdjian, A., Gromov, V., Kazhukalo, I., Kozlov, G., Komissarov, V., . . . Mishkinyuk, V. (1993). Soviet developments of planetary rovers in period of 1964–1990. In D. Moura (Ed.), *Missions, technologies and design of planetary mobile vehicles* (pp. 25–43). Toulouse, France: Cepadues.
- Kim, W. S., & Bejczy, A. K. (1993). Demonstration of a high-fidelity predictive/preview display technique for telerobotic servicing in space. *IEEE Transactions on Robotics and Automation*, 9, 698–702.
- Klein, M., Warm, J., Riley, M., Matthews, G., Gaitonde, K., & Donovan, J. (2008). Perceptual distortions produce multidimensional stress profiles in novice users of an endoscopic surgery simulator. *Human Factors*, 50, 291–300.
- Lamb, P., & Owen, D. (2005). Human performance in space telerobotic manipulation. In *ACM Virtual Reality Software and Technology* (pp. 31–37). New York, NY: ACM.
- Lee, S., Lees, D., Cohen, T., Allan, M., Deans, M., Morse, T., . . . Smith, T. (2011). Reusable science tools for analog exploration missions: GDS Web Tools, VERVE, and Gigapan Voyage. *Acta Astronautica*, 90, 268–288.
- Leger, P., Trebi-Ollennu, A., Wright, J., Mawell, S., Bonitz, R., Biesiadecki, J., . . . Maimone, M. (2005). Mars Exploration Rover surface operations: Driving Spirit at Gusev Crater. In *Proceedings of the IEEE International Conference on Systems, Man and Cybernetics* (Vol. 2, pp. 1815–1822). New York, NY: IEEE.



- Lester, D., & Thronson, H. (2011). Low-latency lunar surface telerobotics from Earth–moon libration points. In *Proceedings of the 2011 AIAA Space Conference* (AIAA-2011-7341). Reston, VA: American Institute of Aeronautics and Astronautics.
- Lester, D., Hodges, K., Ower, C., & Klaus, K. (2012). Exploration telepresence from Earth–moon Lagrange points. In *Proceedings of the IAF/AIAA Global Space Exploration Conference* (GLEX-2012.04.2.112250). Reston, VA: American Institute of Aeronautics and Astronautics.
- Macedo, J., Kaber, D., Endsley, M., Powanusorn, P., & Myung, S. (1998). The effect of automated compensation for incongruent axes on teleoperator performance. *Human Factors*, *40*, 541–553.
- Maida, J., Bowen, C., & Pace, J. (2007). Improving robotic operator performance using augmented reality. In *Proceedings of the Human Factors and Ergonomics Society 51st Annual Meeting* (pp. 1635–1639). Santa Monica, CA: Human Factors and Ergonomics Society.
- McGregor, R., & Oshinowo, L. (2001, June). *Flight 6A: Deployment and checkout of the Space Station Remote Manipulator System (SSRMS)*. Paper presented at the 6th International Symposium on Artificial Intelligence, Robotics and Automation in Space, Quebec, Canada.
- Menchaca-Brandan, M., Liu, A., Oman, C., & Natapoff, A. (2007). Influence of perspective-taking and mental rotation abilities in space teleoperation. In *Proceedings of the ACM Conference on Human–Robot Interaction* (pp. 271–278). New York, NY: ACM.
- Mirmalek, Z. (2008). Working time on Mars. *KronoScope*, *8*, 159–178.
- Mishkin, A., & Laubach, S. (2006, June). *From prime to extended mission: Evolution of the MER tactical uplink process*. Paper presented at the 9th International Conference on Space Operations, Rome, Italy.
- Mishkin, A., Lee, Y., Korth, D., & LeBlanc, T. (2007, March). *Human–robotic missions to the moon and Mars: Operations design implications*. Paper presented at the IEEE Aerospace Conference, Big Sky, MT.
- Mishkin, A., Limonadi, D., Laubach, S., & Bass, D. (2006). Working the Martian night shift: The MER surface operations process. *IEEE Robotics and Automation Magazine*, *13*(2), 46–53.
- National Aeronautics and Space Administration. (2011). *Mars Science Laboratory launch* [Press kit]. Washington, DC: Author.
- Niculescu, S., Taoutaou, D., & Lozano, R. (2003). Bilateral teleoperation with communications delay. *International Journal of Robust and Nonlinear Control*, *13*, 873–883.
- Nielsen, C., Goodrich, M., & Ricks, R. (2007). Ecological interfaces for improving mobile robot teleoperation. *IEEE Transactions on Robotics*, *23*, 927–941.
- Niemeyer, G., & Slotine, J. E. (2004). Telemanipulation with time delays. *International Journal of Robotics Research*, *23*, 873–890.
- Norris, J., Powell, M., Vona, M., Backes, P., & Wick, J. (2005). Mars Exploration Rover operations with the science activity planner. In *Proceedings of the IEEE Conference on Robotics and Automation* (pp. 4618–4623). New York, NY: IEEE.
- Oleson, S., Landis, G., McGuire, M., & Schmidt, G. (2011). HERRO mission to Mars using telerobotic surface exploration from orbit. *Journal of the British Interplanetary Society*, *64*, 304–313.
- Parke, B., & Mishkin, A. (2005). Best practices in shift handover communication: Mars Exploration Rover surface operations. In *Proceedings of the International Association for the Advancement of Space Safety Conference* (pp. 25–27). Nice, France: ESA.
- Piedboeuf, J., & Dupuis, É. (2003). Recent Canadian activities in space automation and robotics—an overview. In *Proceedings of the 7th International Symposium on Artificial Intelligence, Robotics and Automation in Space* (pp. 19–23). Montreal, Canada: iSAIRAS.
- Reeves, G., & Snyder, J. (2005). An overview of the Mars Exploration Rovers flight software. In *Proceedings of the IEEE Conference on Systems, Man and Cybernetics* (Vol. 1 pp. 1–7). New York, NY: IEEE.
- Rehmark, F., Bluethmann, W., Rochlis, J., Huber, E., & Ambrose, R. (2003). An effective division of labor between human and robotic agents performing a cooperative assembly task. In *Proceedings of Humanoids* (n.p.). New York, NY: IEEE.
- Rehmark, F., Currie, N., Ambrose, R., & Culbert, C. (2004). Human-robot teaming in a multi-agent space assembly task. In *Proceedings of the World Automation Congress* (pp. 69–74). Albuquerque, NM: TSI Press.
- Rembala, R., & Aziz, S. (2007). Increasing the utilization of the ISS Mobile Servicing System through ground control. *Acta Astronautica*, *61*, 691–698.
- Rembala, R., & Ower, C. (2009). Robotic assembly and maintenance of future space stations based on the ISS mission operations experience. *Acta Astronautica*, *65*, 912–920.

- Rochlis, J., Delgado, F., & Graham, J. (2006). Science crew operations and utility testbed. *Industrial Robot*, 33, 443–450.
- Ross, A., Kosmo, J., & Janoiko, B. (2012). Historical synopses of Desert RATS 1997–2010 and a preview of Desert RATS 2011. *Acta Astronautica*, 90, 182–202.
- Sachdev, S. (1986). Canadarm: A review of its flights. *Journal of Vacuum Science and Technology*, 4, 268–272.
- Schreckenghost, D., Milam, T., & Fong, T. (2010). Measuring performance in real-time during remote human–robot operations with adjustable autonomy. *IEEE Intelligent Systems*, 2010, 36–45.
- Shaw, J., Saleh, J., & Hoffman, J. (2007). Review and synthesis of considerations in architecting heterogeneous teams of humans and robots for optimal space exploration. *IEEE Transactions on Systems, Man, and Cybernetics, Part C: Applications and Reviews*, 37, 779–793.
- Sheridan, T. (1993). Space teleoperation through time delay: Review and prognosis. *IEEE Transactions on Robotics and Automation*, 9, 592–606.
- Sheridan, T. (1995). Teleoperation, telerobotics and telepresence: A progress report. *Control Engineering Practice*, 3, 204–214.
- Shillcutt, K., Burridge, R., & Graham, J. (2002). *Boudreau the Robot (a.k.a. EVA Robotic Assistant)*. (AAAI Tech. Rep. FS-02-03). Menlo Park, CA: Association for the Advancement of Artificial Intelligence.
- Shirley, D., & Matijevic, J. (1995). Mars Pathfinder microrover. *Autonomous Robots*, 2, 283–289.
- Singer, S. (2012). *Creating an objective methodology for human–robot team configuration selection* (Unpublished doctoral dissertation). University of Maryland, College Park.
- Steinfeld, A., Fong, T., Kaber, D., Lewis, M., Scholtz, J., Schultz, A., & Goodrich, M. (2006). Common metrics for human–robot interaction. In *Proceedings of the ACM Conference on Human–Robot Interaction* (pp. 33–40). New York, NY: ACM.
- Stuart, M. A., Jensen, D. G., Bierschwale, J. M., Wilmington, R. P., Adam, S. C., & Diaz, M. F. (1990). Hand controller commonality evaluation process. In *Proceedings of the Human Factors and Ergonomics Society 34th Annual Meeting* (pp. 121–125). Santa Monica, CA: Human Factors and Ergonomics Society.
- Uchiyama, M., Konno, A., Uchiyama, T., & Kanda, S. (2002). Development of a flexible dual-arm manipulator testbed for space robotics. In *Proceedings of the IEEE International Workshop on Intelligent Robots and Systems* (pp. 375–381). New York, NY: IEEE.
- Vertesi, J. (2012). Seeing like a rover: Visualization, embodiment, and interaction on the Mars Exploration Rover mission. *Social Studies of Science*, 42, 393–414.
- Welch, R., Hoover, M., & Southward, E. (2009). Cognitive performance during prismatic displacement as a partial analogue of space fog. *Aviation, Space, and Environmental Medicine*, 80, 771–780.
- Whitmore, M., Stealey, S., & Wilmington, R. (1991). *Space station hand controller commonality test report* (JSC 32125/LESC 29020). Houston, TX: NASA Johnson Space Center.
- Wickens, C., & Carswell, M. (2012). Information processing. In G. Salvendy (Ed.), *Handbook of human factors and ergonomics* (4th ed., pp. 117–161). New York, NY: Wiley.

## ABOUT THE AUTHORS

**Terrence Fong** is the director of the Intelligent Robotics Group at the National Aeronautics and Space Administration (NASA) Ames Research Center and is the manager of the NASA Human Exploration Telerobotics project. From 2002 to 2004, he was the deputy leader of the Virtual Reality and Active Interfaces Group at the Swiss Federal Institute of Technology (EPFL). From 1997 to 2000, he was vice president of development for Fourth Planet, Inc., a developer of real-time data and network visualization software. He is a founding member of the IEEE Space Robotics technical committee and a member of the AIAA Space Automation and Robotics technical committee. He was program cochair (2007), general cochair (2008), and steering committee member (2006–2011) for the ACM/IEEE Human–Robot Interaction conference. He has published more than 100 papers in analog field testing, field and mobile robotics, planetary

robotics, human–robot interaction, and virtual environment user interfaces. He received his BS and MS in aeronautics and astronautics from the Massachusetts Institute of Technology and his PhD in robotics from Carnegie Mellon University.

**Jennifer Rochlis Zumbado** is the human systems integration lead for the Human Health and Performance Directorate at the NASA Johnson Space Center (JSC). Prior to this, she was an engineer in the JSC Software, Robotics and Simulation Division. She is currently the principal investigator of the Human Robotic Interface project for NASA's Human Research Program and NASA's human health and performance lead for the Commercial Crew Program. She was previously lead for the NASA Constellation program Human Systems Integration Group. She has received a JSC Center Director's Innovation Award for her work on telerobotics projects, including Robonaut, the next-generation lunar/Martian rovers, and ground control of Space Station and Space Shuttle arms. She is a member of the Human Factors and Ergonomics Society, the National Management Association, and the National Defense Industrial Association. Her research interests include human systems integration, human factors engineering, teleoperation and telerobotics, and human–computer interfaces. She received her BA in physics from Mount Holyoke College and her MS and PhD in aeronautics and astronautics from the Massachusetts Institute of Technology.

**Nancy Currie** is a principal engineer with the NASA Engineering and Safety Center at the NASA Johnson Space Center. A retired U.S. Army colonel and master Army aviator, she was selected as an astronaut in 1990. Currie is a veteran of four Space Shuttle missions and has accrued 1,000 hr in space. She was a mission specialist and flight engineer on STS-57 (1993), STS-70 (1995), the first International Space Station assembly mission STS-88 (1998), and the fourth Hubble Space Telescope servicing mission STS-109 (2002). During 2012, she was a visiting associate professor in the Department of Industrial Engineering at North Carolina State University. She has used her expertise in space robotic systems operations to contribute to the development and analysis of human–robotic systems interfaces for advanced space systems. She received a bachelor's degree, with honors, in biological science from The Ohio State University, an MS in safety engineering from the University of Southern California, and a PhD in industrial engineering with an emphasis in automated systems and human factors engineering from the University of Houston.

**Andrew Mishkin** is a principal engineer at the Jet Propulsion Laboratory, where he has been involved in the development of robotic vehicles and mission operations for more than 20 years. He is currently the sequencing team chief for the Mars Science Laboratory mission. Previously, he was the Command and Control Team lead for the Constellation Program as well as lead for a multicenter team providing systems engineering support to the Constellation Mission Operations Project at Johnson Space Center. In 2000, he joined the Mars Exploration Rover (MER) mission as the mission operations development manager and subsequently became the MER Sequence Team chief focused on surface operations. Prior to this, he was a systems engineer on the Sojourner rover team during the Mars Pathfinder mission and commanded the rover during its exploration

of Mars. He is the recipient of both the NASA Exceptional Achievement and Exceptional Service Medals for his work on MER and Mars Pathfinder and was selected as one of the “35 People Who Made the Year” in the December 1997 edition of *Vanity Fair*. He received a BS in systems engineering and an MS in engineering from the University of California, Los Angeles.

**David L. Akin** is an associate professor in the Department of Aerospace Engineering at the University of Maryland, where he is also the director of the Space Systems Laboratory. He was the principal investigator on the Experimental Assembly of Structures in EVA, a flight experiment on the Space Shuttle mission 61-B, and for the ParaShield Flight Test Experiment on the American Rocket Company SET-1 mission. He has also headed the development of a number of integrated robotic systems for space, undersea, and medical rehabilitation, including the Ranger Dexterous Servicing System (the only U.S.-developed dexterous robot approved for Space Shuttle flight operations) and the SAMURAI deep submergence sampling system for use on hovering autonomous underwater vehicles. He is a member of the AIAA Space Automation and Robotics Technical Committee and has written over 100 papers on aerospace systems design, extravehicular activity, teleoperation, robotics, and space human factors. He received his SB, SM, and ScD degrees in aeronautics and astronautics from the Massachusetts Institute of Technology.