

Speed Control of DC Motor using Pid Controller Based on Matlab

Aditya Pratap Singh

Asst Prof, EX Dept. TIEIT BHOPAL, MP

Udit Narayan

Student of BE, TIEIT, BHOPAL, MP

Akash Verma

Student of BE, TIEIT, BHOPAL, MP

Abstract: This paper is to design PID controller to supervise and control the speed response of the DC motor and MATLAB program is used for calculation and simulation PID controllers are widely used in a industrial plants because of their simplicity and robustness. Industrial processes are subjected to variation in parameters and parameter perturbations. We are choosing PID parameters and discussed

Key words: DC motor, PID controller, MATLAB representation

I. INTRODUCTION

The DC motors have been popular in the industry control area for a long time, because they have many good characteristics, for example: high start torque characteristic, high response performance, easier to be linear control...etc.

The speed of a DC motor is given by the relationship

$$N = \frac{V - I_a R_a}{k\phi}$$

This Equation show that the speed is dependent on the supply voltage V, the armature circuit resistance Ra, and field flux Φ , which is produced by the field current. This paper describes the MATLAB/ SIMULINK of the DC motor speed control method namely field resistance, armature voltage, armature resistance control method and feedback control system for DC motor drives [4].

When speed control over a wide range is required, combination of armature voltage control and field flux control is used. This combination permits the ratio of maximum to minimum speed to be 20 to 40. With closed loop control, this range can be extended up to 200.

The parameters of the PID controller k_p , k_i and k_d (or k_p , T_i and T_d) can be manipulated to produce various response Curves from a given process as we will see later [6].

II. PID CONTROLLER

The combination of proportional, integral and derivative control action is called PID control action. PID controllers are commonly used to regulate the time-domain behavior of many different types of dynamic plants. These controllers are extremely popular because they can usually provide good closed-loop response characteristics.

Consider the feedback system architecture that is shown in Fig. 1 where it can be assumed that the plant is a DC motor whose speed must be accurately regulated [1].

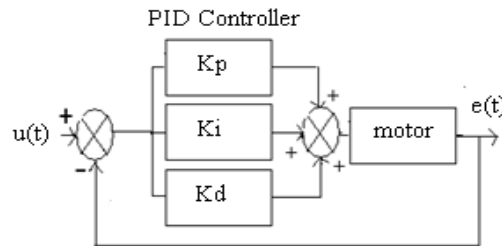

Fig - 1

The PID controller is placed in the forward path, so that its output becomes the voltage applied to the motor's armature the feedback signal is a velocity, measured by a tachometer .the output velocity signal $C(t)$ is summed with a reference or command signal $R(t)$ to form the error signal $e(t)$. Finally, the error signal is the input to the PID controller [5].

$$u = k_p e + k_i \int e dt + k_d \frac{de}{dt}$$

III. DC MOTOR MATHEMATICS MODEL AND THE CONTROL THEORY

DC motors have speed-control capability, which means that speed, torque and even direction of rotation can be changed at any time to meet new conditions [3] .The electric circuit of the armature and the free body diagram of the rotor are shown in the following fig- 2, and [2].

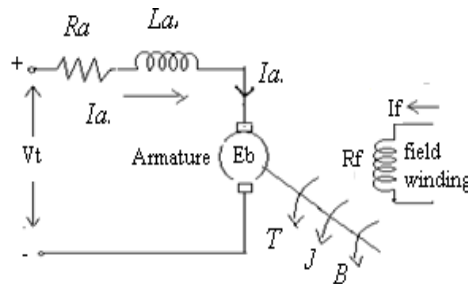

Fig - 2

Let R_a =Armature Resistance,

L_a =Armature self inductance caused by armature flux,

i_a = Armature current,

i_f = field current,

E_b =Back EMF in armature,

V =Applied voltage,

T =Torque developed by the motor,

θ = Angular displacement of the motor shaft,

J =Equivalent moment of inertia of motor shaft & load referred to the motor,

B = Equivalent Coefficient of friction of motor shaft & load referred to the motor.

The DC motors are generally used in the linear range of the magnetization curve. Therefore, air gap flux Φ is proportional of the field current i.e.

$$\Phi \propto i_f$$

$$\Phi = k_f i_f \dots\dots\dots (1)$$

Where K_f is a constant

The torque T developed by the motor is proportional to the armature current and air gap flux i.e.

$$T \propto \Phi i_a$$

$$T = k_a \Phi i_a$$

$$T = k_a k_f \Phi i_a$$

$$T = k i_a \dots\dots\dots (2)$$

Where K_T = motor torque constant

The motor back EMF being proportional to speed is given as

$$E_b \propto \Phi \omega$$

$$E_b = k_b \omega$$

$$E_b = k_b \frac{d\theta}{dt} \dots\dots\dots (3)$$

Where K_b = back emf constant

Applying KVL in the armature circuit

$$v = R a i_a + L a \frac{d i_a}{d t} + E_b \dots\dots\dots (4)$$

And the dynamic equation with moment of inertia & coefficient of friction will be

$$T = J \frac{d^2 \theta}{d t^2} + B \frac{d \theta}{d t} \dots\dots\dots (5)$$

And with load torque

$$T = J \frac{d^2 \theta}{d t^2} + B \frac{d \theta}{d t} + T_L \dots\dots\dots (6)$$

Take the laplace transform of equation of (2), (3), (4) and (5)

$$T(s) = K I_a(s)$$

$$E_b(s) = K_b s \theta(s)$$

$$V(s) = I_a(s)(R_a + s L_a) + E_b$$

$$V(s) - E_b(s) = I_a(s)(R_a + s L_a)$$

$$T(s) = (J s^2 + s B) \theta(s)$$

$$T(s) = (J s + B) s \theta(s)$$

or

$$T(s) = (J s + B) \omega(s)$$

$$T(s) = K I_a(s)$$

A Block diagram of armature controlled d. c. motor

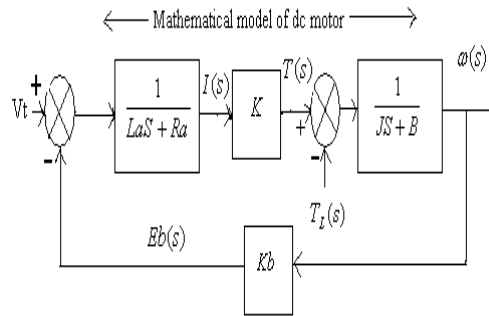

Fig- 3

The transfer function of DC motor speed with respect to the input voltage can be written as follows [2].

$$G(s) = \frac{\omega(s)}{V(s)} = \frac{K_T}{(R_a + sL_a)(Js + B) + K_b K_T} \dots\dots\dots (7)$$

From equation (7) the armature inductance is very small in

practices, hence, the transfer function of DC motor speed to the input voltage can be simplified as Follows,

$$G(s) = \frac{\omega(s)}{V(s)} = \frac{K_m}{\tau s + 1} \dots\dots\dots (8)$$

Where $K_m = \frac{K_T}{R_a B + K_b K_T}$ is a motor gain and $\tau = \frac{R_a J}{R_a B + K_b K_T}$ is the motor time constant

From equation (8), the transfer function can be drawn the DC motor system block diagram which is shown in

Key point; Field controlled dc motor is open loop while armature controlled is closed loop system. Hence armature controlled dc motor are preferred over field controlled system

For small size motor field control is advantageous because only a low power servo amplifier is required while the armature current which is not large can be supplied from an expensive constant current amplifier.

For large size motor it is on the whole cheaper to use armature control scheme. Further in armature controlled motor, back emf contributes additional damping over and above that provided by load friction.

IV. MATLAB REPRESENTATION AND SYSTEM RESPONSE

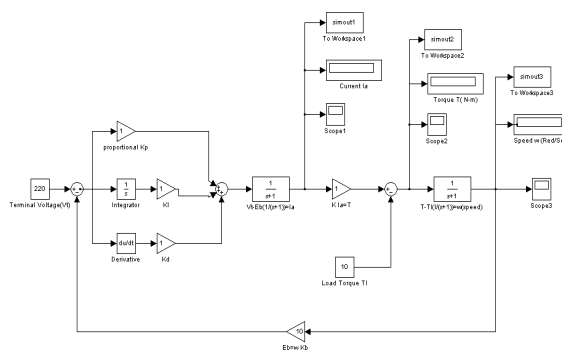

Fig- 4

A. PROPORTIONAL-INTEGRAL-DERIVATIVE CONTROL (PID)

The combination of proportional, integral and derivative control action is called PID action control and the controller is called three action controllers.

Here the proportional part of the control action repeats the change of error and derivative part of the control action adds an increment of output so that proportional plus derivative action is shifted ahead in time.

The integral part adds a further increment of output proportional to the area under the deviation line. The combination of proportional, integral and derivative action may be made in any sequence as shown.

Now, we increase the gain K_d , with $K_p=5$; $K_i=10$. All results are illustrated in the Table 3 and the corresponding plots are shown in Fig .

From the results we see that the rise time increase from (0.50 sec to 0.82sec) for ($K_d=1$ to $K_d=4$) and the overshoot from (23% to 12%) and there is small change in the settling time. Hence the steady state error is completely zero.

Kd	Rise Time(sec)	Maximum Overshoot (%)	Steady State Error	Peak Amplitude of Velocity (red/sec)
1	0.50	23.39	0	40
2	0.65	15.95	0	40
3	0.71	14.52	0	40
4	0.82	12.58	0	40

Table – 1 PID control

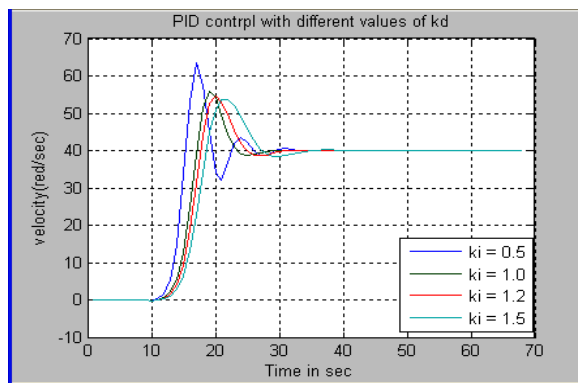

Fig- 5

So now we know that if we use a PID controller with: $K_p=4, k_i=1$ and $K_d=1$; all our design requirements will be satisfied and the response looks like

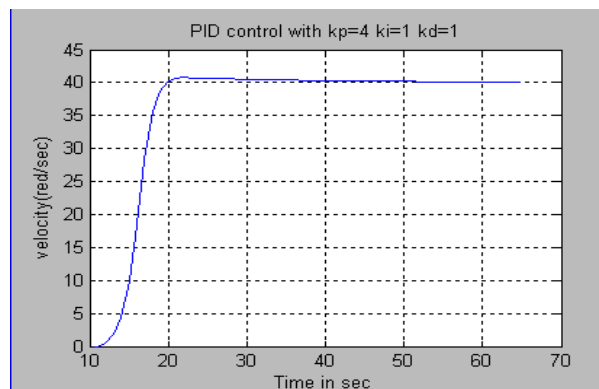

Fig- 6

PID controller with: $K_p=4, K_i=1$ and $K_d=1$

Effects of PID controllers parameters k_p , k_i and k_d on a closed loop system are summarized in the table below.

Closed loop Response	Rise Time(sec)	Maximum Overshoot(%)	Settling Time(sec)	Steady State Error
As increase of K_p	Decrease	Increase	Small change	Decrease
As increase of K_i	Decrease	Increase	Increase	Eliminate
As increase of K_d	Small change	Decrease	Decrease	Small change

Table- 2

V. CONCLUSION

Accurate performance of a motor is desired feature for any industrial application.

As the age of motor increases its performance also decreases with aging, so it is desired to evaluate the performance of motor from time to time for efficient operation

The conventional method for calculating output performance indices are quite time consuming.

The PID based approach algorithm worked satisfactory for the test system.

The important observations made during the studies are

- 1) The solution time for proposed PID approach is only a fraction of time taken by conventional algorithm.
- 2) A proportional controller K_p will have the effect of reducing the rise time and reduce but never eliminate the steady state error.
- 3) An internal controller K_i will have the effect of eliminate the steady state error but it may make the transient response worse.
- 4) A derivative controller K_d will have the effect of increasing the stability of the system and reducing the overshoot and improve the transient response.
- 5) The output performance obtained by normalized value in PID is very close and near to accuracy.
- 6) MATLAB used for simulation of entire project is sophisticated and user friendly software.

It must be mentioned that the efficiency of the speed algorithm can be improved by using more efficient learning techniques and dynamic weight selection algorithm

REFERENCES

- [1] Fatiha Loucif "DC Motor Speed Control Using PID controller" department of electrical engg and information, hunan university, Changsha, hunan, china(E-mail: fatiha2002@msn.com) in june 2-5 KINTEX,

Gonggi, kora in ICCAS2005

[2] Guoshing Huang, Shuocheng Lee Department of Electronic Engineering, National Chin-Yi University of Technology, 35, Lane 215, Chung-Shan Rd., Sec. 1, Taiping, Taichung, Taiwan, 41111, ROC
E-mail:hgs@ncut.edu.tw in PC-based PID Speed Control in DC Motor 2008 IEEE page no 400-407

[3] Saffet Ayasun, Gu¨ Ltekin Karbeyaz Department of Electrical and Electronics Engineering, Nigde University, Nigde 51100, Turkey 12 March 2007 Wiley Periodicals Inc

[4] Electrical machine by Dr.P S Bimbhra by Khanna publishers New Edition

[5] Automatic control systm by S Hasan saeed, published by S K Kataria vol vi

[6] Control system engineering, by Nagrath & Gopal, published by New Age International publishers Fifth Edition