

SPICE Modeling of Memristive, Memcapacitive and Meminductive Systems

Dalibor Biolek

Dept. of EE/Microelectronics
UD Brno/BUT
Brno, Czech Republic
dalibor.biolek@unob.cz

Zdenek Biolek

Dept. of Informatics
SSIER
Roznov p.R., Czech Republic
zdenek.biolek@roznovskastredni.cz

Viera Biolkova

Dept. of Radio Electronics
BUT
Brno, Czech Republic
biolkova@feec.vutbr.cz

Abstract— A methodology of SPICE modeling of general memristive, memcapacitive, and meminductive systems is proposed and their special cases such as memristors (MR), memcapacitors (MC), and meminductors (ML) are given. These elements are included alongside the conventional R, C, and L elements in a proposed constellation, which generalizes the hitherto approach when the memristor is regarded as a fourth missing passive element. It is shown that the memristor, designed in HP laboratories, can be modeled as a first-order memristive system with nonlinear dependence of the time derivative of the state variable on this variable and on the current flowing through. The outputs of SPICE analyses are consistent with the hitherto published results.

Keywords— memristor, memcapacitor, meminductor

I. INTRODUCTION

The paper [1] in Nature from May 1, 2008, announcing the first experimental design of the memristor from Hewlett-Packard (HP) labs, has caused a tremendously increased interest in this so-called fourth fundamental passive circuit element, whose existence was predicted in 1971 by Leon Chua in [2]. Intensive research is in progress in HP labs towards revolutionary applications in high-density RRAM (Resistive Random-Access Memory), when the memristor acts as a switch [3]. A concept of memristors as analog elements is also being developed. Arrayed in high-capacity matrices, memristors can simulate complex neural networks and processes, associated with the operation of human brain [3].

The memristor is a special case of a more general memristive system which was defined by Chua and Kang in [4]. In January 2009, in addition to memristive systems, the memcapacitive and meminductive systems were defined as well as their special subsystems, namely memcapacitors and meminductors [5]. At the International Symposium [6] in November 2008, the latter two elements were specified by Leon Chua as lossless memory passive elements, which could play a more important role in the future than memristors, which produce losses during the reading and writing processes.

Seeing that the memristor from HP labs will probably not be available as a commercial circuit component for a few years to come, and that the prospective design of the solid-state memcapacitor and meminductor has not been initiated, the role

of relevant computer models increases which would enable an effective analysis of such interesting circuit elements through simulation experiments. Since the behavior of a number of systems of inanimate and animate nature exhibits memory effects, it is also reasonable to follow the development in the modeling of general memristive, memcapacitive, and meminductive systems. With regard to the universal application of the SPICE simulation program in electrical engineering, it is meaningful to focus on the modeling of such systems just in the SPICE-family programs.

The purpose of this paper is to implement a methodology of SPICE modeling of general memristive, memcapacitive, and meminductive systems on the basis of their mathematical definitions from [5]. The paper has the following structure: Section 2, which follows this Introduction, summarizes the definitions of systems with memory effects (mem-systems for short), referred to in [5], and their set is extended to a complete system of memory elements controlled by voltage, current, flux, and charge. A notation introduced by Leon Chua in [6] is used here. In terms of these definitions, a special layout of passive memory-less and memory elements is proposed, and several inferential aspects are addressed. The general structure of SPICE models of n -th order memristive, memcapacitive, and meminductive systems is described in Section 3. Section 4 contains a concrete SPICE model of the memristor from HP labs together with a demonstration of the analysis results.

II. DEFINITION OF „MEM-SYSTEMS“

The following quantities, derived from voltage v and current i via time-domain integration within the interval from t_0 to t , have been introduced in [6]: electric charge q , flux φ , integral of charge σ , and integral of flux ρ :

$$q = \int_{t_0}^t i(\tau) d\tau, \quad \varphi = \int_{t_0}^t v(\tau) d\tau, \quad \sigma = \int_{t_0}^t q(\tau) d\tau, \quad \rho = \int_{t_0}^t \varphi(\tau) d\tau \quad (1)$$

The generalization of the definitions from [5] yields port and state equations of current controlled (CC), voltage controlled (VC), charge controlled (QC), and flux controlled (FC) systems of memristive (MrS), memcapacitive (McS), and meminductive (MIS) natures, summarized in Table I. According to [5], the systems are of n -th order, meaning that x is a vector containing n state variables, i.e. $x = [x_1, x_2, \dots, x_n]$.

The quantities R_M , G_M , C_M , D_M , L_M , and Λ_M denote memristance, memductance, memcapacitance, inverse memcapacitance, meminductance, and inverse meminductance, respectively. The corresponding physical units are Ohm, Siemens, Farad, Farad⁻¹, Henry, and Henry⁻¹. The type of system control is derived from the subject which controls the time derivative of the system state. For example, the time derivative of the state of the CCMrS (Current-Controlled Memristive System) is derived from the current passing through the memristive port.

TABLE I. DEFINITION EQUATIONS OF MEM-SYSTEMS

system type	port equations	state equations
CCMrS	$v = R_M(x, i, t)i$	$\dot{x} = f(x, i, t)$
VCMrS	$i = G_M(x, v, t)v$	$\dot{x} = f(x, v, t)$
VCMcS	$q = C_M(x, v, t)v$	$\dot{x} = f(x, v, t)$
QCMcS	$v = D_M(x, q, t)q$	$\dot{x} = f(x, q, t)$
CCMIS	$\varphi = L_M(x, i, t)i$	$\dot{x} = f(x, i, t)$
FCMIS	$i = \Lambda_M(x, \varphi, t)\varphi$	$\dot{x} = f(x, \varphi, t)$

Table II summarizes the definition equations of memristor (MR), memcapacitor (MC), and meminductor (ML), all of them being controlled by current (CC), voltage (VC), charge (QC), and flux (FC). In these special cases of first-order “mem-systems”, the state variable is charge or flux (MR), flux or integral of charge (MC), and charge or integral of flux (ML). The type of control is subject to identical rules as for the general mem-systems. For example, that is why the memristor in the first row of Table II is specified as CC (current controlled), because the derivative of the state (charge) is controlled by electric current. However, such a memristor is specified in [5] as QC (charge-controlled).

TABLE II. DEFINITION EQUATIONS OF MEM-ELEMENTS

element type	port equations	constitutive equations
CCMR	$v = R_M(q)i$	$\varphi = \varphi(q), R_M(q) = \frac{d\varphi}{dq}$
VCMR	$i = G_M(\varphi)v$	$q = q(\varphi), G_M(\varphi) = \frac{dq}{d\varphi}$
VCMC	$q = C_M(\varphi)v$	$\sigma = \sigma(\varphi), C_M(\varphi) = \frac{d\sigma}{d\varphi}$
QCMC	$v = D_M(\sigma)q$	$\varphi = \varphi(\sigma), D_M(\sigma) = \frac{d\varphi}{d\sigma}$
CCML	$\varphi = L_M(q)i$	$\rho = \rho(q), L_M(q) = \frac{d\rho}{dq}$
FCML	$i = \Lambda_M(\rho)\varphi$	$q = q(\rho), \Lambda_M(\rho) = \frac{dq}{d\rho}$

The graphical representation of port equations, e.g. $v = R_M(q)i$ for the memristor CCMR, shows the well-known pinched loops as a consequence of the memory effects. On the other hand, the constitutive equations, e.g. $\varphi = \varphi(q)$ for the memristor CCMR, describe single-valued functions. The slope of the corresponding characteristics at a given operating point determines the differential parameter, the memristance in this case.

Note that the mem-elements from Table II are special cases of the so-called higher-order elements, organized to a periodic table such that it resembles the well-known Mendeleev periodical table of chemical elements [7]. In the light of the above, Fig. 1 offers another view on the relationship between the passive R , L , and C elements and their memory versions. This figure can be likened to a house with two floors, the floor of passive non-memory R , C , and L elements, and the upstairs of mem-elements, containing the memristor, memcapacitor, and meminductor. In fact, the fourth fundamental passive element, the memristor, postulated by Chua in [1] on the basis of the well-known “four-square” symmetry, is located on the higher floor of the mem-elements. We can wonder whether somebody will find other practically exploitable higher-order elements on some other floor.

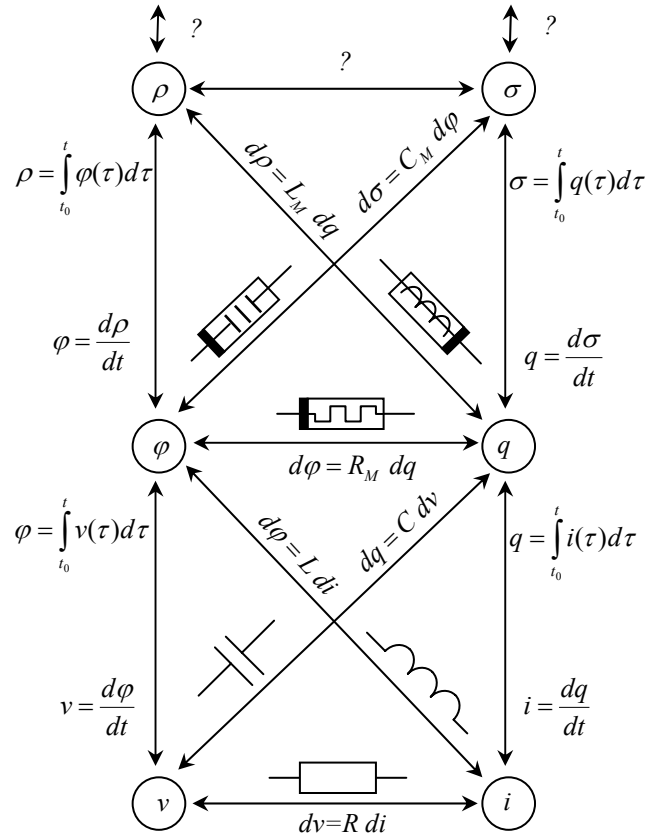

Figure 1. System of fundamental passive memory-less and mem-elements.

III. SPICE MODELING OF MEM-SYSTEMS

The port and state equations of n -th order mem-systems, summarized in Table I, are the starting points for the SPICE modeling. The resulting SPICE model will depend on the corresponding equations of concrete mem-system.

The block diagram of the general model is shown in Fig. 2. The „port“ subblock contains a model of system interaction with its neighborhood via its terminal voltage and current. Since some of the port equations in Table I also contain other circuit variables, namely charge and flux, it is necessary to model them via the time-domain integration of current and voltage. The corresponding integrators must be a part of the „port“ subblock.

The state equations are modeled utilizing n integrators. The integrators are implemented by G -type controlled current sources, driving grounded 1-Farad capacitors, also enabling the adjustment of initial conditions. In order to define DC paths to ground, capacitors are provided by shunting resistors.

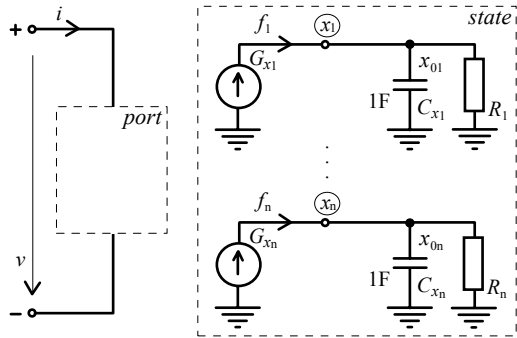

Figure 2. Block diagram of the SPICE model of general n -th order mem-system.

TABLE III. SPICE MODEL OF THE „PORT“ TYPE

system type	SPICE model of the „PORT“ type
CCMrS	
VCMrS	
VCMcS	
QCMcS	
CCMIS	
FCMIS	

A schematic of the section of modeling of state equations is illustrated in Fig. 2. The currents of G -type sources are modeled by means of equations which describe the individual components f_1, f_2, \dots, f_n of vector function f of the corresponding state equation. The nodal voltages of nodes x_1, x_2, \dots, x_n will represent the numerical values of state variables x_1, x_2, \dots, x_n .

SPICE models of the „port“ type are shown in Table III. For the memristive system, the relation between port voltage and current is determined by the memristance, i.e. variable resistance, which can be modeled in SPICE via a controlled voltage or current source (see rows CCMrS and VCMrS). The relationship between voltage and current for memcapacitive systems (rows VCMcS and QCMcS) is advantageously modeled by controlled voltage source: the time-domain integral (the charge) is computed from port current i and the result is in the form of the voltage of node $inti$. This voltage is simultaneously used for evaluating the port voltage. For meminductive systems (rows CCMIS and FCMIS), the input port is modeled by controlled current source: The time-domain integral (the flux) is computed from port voltage v , causing the voltage of node $intv$. Then the source, connected to the port, which is controlled by this voltage, determines the port current.

The fact that the input port of the system is directly modeled via a voltage or current source can cause practical problems in the course of simulating application circuits. For example, the VCMcS model cannot be directly driven by the voltage source because of the potential conflict of two ideal voltage sources being connected in parallel. Such problems can be solved on a case-by-case basis, for example, utilizing a specific form of the port equations, as will be shown in Section IV on the example of the model of memristor manufactured in HP labs [1].

IV. SPICE MODEL OF HP-MEMRISTOR

The physical model of the memristor from [1], shown in Fig. 3, consists of a two-layer thin film (size $D \approx 10$ nm) of TiO_2 , sandwiched between platinum contacts. One of the layers is doped with oxygen vacancies and thus it behaves as a semiconductor. The second, undoped region, has an insulating property. As a consequence of complex material processes, the width w of the doped region is modulated depending on the amount of electric charge passing through the memristor. With electric current passing in a given direction, the boundary between the two regions is moving in the same direction. The total resistance of the memristor, R_{mem} , is a sum of the resistances of the doped and undoped regions,

$$R_{mem}(x) = R_{on}x + R_{off}(1-x) = R_{off} - (R_{off} - R_{on})x, \quad (2)$$

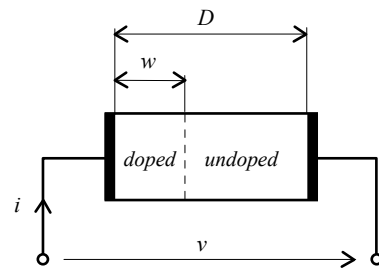

Figure 3. Memristor model according to [1].

where
$$x = \frac{w}{D} \in (0,1) \quad (3)$$

is the width of the doped region, referenced to the total length D of the TiO_2 layer, and R_{off} and R_{on} are the limit values of the memristor resistance for $w=0$ and $w=D$. The ratio of the two resistances is usually given as $10^2 - 10^3$.

The speed of the movement of the boundary between the doped and undoped regions depends on several factors according to state equation [1]

$$\frac{dx}{dt} = ki(t)f(x), k = \frac{\mu_v R_{on}}{D^2}, \quad (4)$$

where $\mu_v \approx 10^{-14} \text{ m}^2\text{s}^{-1}\text{V}^{-1}$ is the so-called dopant mobility. The speed of the boundary between the doped and undoped regions gradually decreases to zero [1]. This phenomenon, called nonlinear dopant drift, can be modeled by the so-called window function $f(x)$ on the right side of Eq. (4). The paper [8] proposes a window function in the following form:

$$f(x) = 1 - (2x - 1)^{2p}, \quad (5)$$

where p is a positive integer.

It follows from the above that this element is a first-order CCMrS, since the state variable is not the charge which is being passed through it but the position of the boundary, which does not depend on the charge at either edge of the layer. A complete SPICE model is listed in Table IV. The resistive port is modeled as a series connection of resistor with fixed resistance R_{off} and a controlled source which models the x -dependent resistance according to Eq. (2).

TABLE IV. SPICE MODEL OF HP MEMRISTOR

```
.SUBCKT memristor Plus Minus PARAMS:
+ Ron=1K Roff=100K Rinit=80K D=10N uv=10F p=1
*****
* STATE EQUATION MODELING *
Gx 0 x value={ I(Emem)*uv*Ron/D^2*f(V(x),p)}
Cx x 0 1 IC={(Roff-Rinit)/(Roff-Ron)}
Raux x 0 1G
*****
* RESISTIVE PORT MODELING *
Emem plus aux value=-I(Emem)*V(x)*(Roff-Ron)
Roff aux minus {Roff}
*****
* WINDOW FUNCTION MODELING *
.func f(x,p)={1-(2*x-1)^(2*p)}
.ENDS memristor
```

Fig. 4 shows the analysis results when the memristor with parameters $R_{on}=100 \Omega$, $R_{off}=16 \text{ k}\Omega$, $R_{init}=11 \text{ k}\Omega$, $p = 10$, is driven by a harmonic voltage with an amplitude of 1.1 V and a frequency of 1 Hz. The responses obtained correspond well to the results published in Nature [1].

ACKNOWLEDGMENT

This work has been supported in part by the Czech Grant Agency under grants Nos. 102/08/0784, 102/08/0851, 102/09/1628, and by the research programmes of BUT No. MSM0021630503/513 and UD Brno No. MO FVT0000403, Czech Republic.

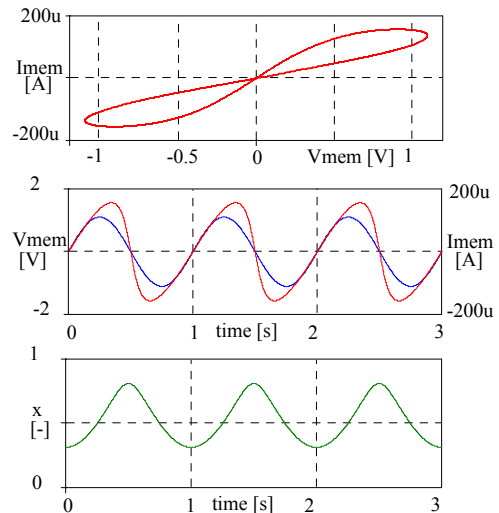

Figure 4. Results of SPICE simulation; HP memristor is driven by a harmonic voltage.

V. CONCLUSIONS

By virtue of a detailed classification of the so-called mem-systems and their special subclasses such as memristor, memcapacitor and meminductor, it is shown that the memristor supplements the system of passive R , C , and L elements in the sense of the missing link between flux and charge, but it also holds its position within the set of passive mem-elements which is connected to the conventional memory-less elements in the sense of the diagram in Fig. 1. The methodology of SPICE modeling of memristive, memcapacitive, and meminductive systems provides unified models of a wide range of such systems, including memristors, memcapacitors, and meminductors as special cases. The illustrative example of setting up a model of the memristor from HP labs indicates that, due to the influence of the boundary effects, it is in fact not a true memristor but a memristive system of the CCMrS type.

REFERENCES

- [1] D.B. Strukov, G.S. Snider, D.R. Stewart and R.S. Williams, "The missing memristor found," Nature, 2008, vol. 453, pp. 80 – 83, 1 May 2008.
- [2] L.O. Chua, "Memristor – the missing circuit element," IEEE Trans. on Circuit Theory, vol. CT-18, no. 5, pp. 507 – 519, 1971.
- [3] R.S. Williams, "How we found the missing memristor," IEEE Spectrum, 2008, December 1, pp. 1-11.
- [4] L.O. Chua and S.M. Kang, "Memristive devices and systems," Proc. of the IEEE, vol. 64, no. 2, pp. 209-223, 1976.
- [5] M.Di Ventura, Y.V. Pershin and L.O. Chua, "Circuit elements with memory: memristors, memcapacitors and meminductors," arXiv:0901.3682v1 [cond-mat.mes-hall] 23 Jan 2009.
- [6] Memristor and Memristive Systems Symposium. University of California, Berkeley, November 21, 2008.
- [7] L. Chua, "Nonlinear Circuit Foundations for Nanodevices, Part I: The Four-Element Tour," Proc. of the IEEE, vol. 91, no. 11, pp. 1830-1859, 2003.
- [8] Y.N. Joglekar and S.J. Wolf, "The elusive memristor: properties of basic electrical circuits," arXiv:0807.3994 v2 [cond-mat.mes-hall] 13 January 2009, pp.1-24.