

 Open access • Journal Article • DOI:10.1103/PHYSREVD.7.887

Spontaneously broken gauge theories of weak interactions and heavy leptons

— [Source link](#) 

James D. Bjorken, C.H. Llewellyn Smith

Institutions: Stanford University

Published on: 01 Feb 1973 - Physical Review D (American Physical Society)

Topics: Gauge boson, Weak isospin, Sterile neutrino, Lepton and Gauge theory

Related papers:

- [Decay Correlations of Heavy Leptons in \$e^+ e^- \rightarrow l^+ l^-\$](#)
- [A Model of Leptons](#)
- [Unified Weak and Electromagnetic Interactions without Neutral Currents](#)
- [Evidence for Anomalous Lepton Production in \$e^+ e^-\$ Annihilation](#)
- [Decay Correlations of Heavy Leptons in \$e^+ e^- \rightarrow \text{Lepton}^+ \text{Lepton}^-\$](#)

Share this paper:    

View more about this paper here: <https://typeset.io/papers/spontaneously-broken-gauge-theories-of-weak-interactions-and-43eh7wqt8e>

SLAC-PUB-1107
(TH) and (EXP)
September 1972

SPONTANEOUSLY BROKEN GAUGE THEORIES
OF WEAK INTERACTIONS AND HEAVY LEPTONS*

J. D. Bjorken and C. H. Llewellyn Smith[†]

Stanford Linear Accelerator Center, Stanford University, Stanford, California 94305

ABSTRACT

Branching ratios and production cross sections are calculated for the heavy leptons which occur in a class of spontaneously broken gauge theories of weak interactions. Several examples of such theories are constructed.

(Submitted to Phys. Rev.)

* Supported by the U. S. Atomic Energy Commission.

[†] Address after August 15, 1972: CERN, Geneva, Switzerland.

I. INTRODUCTION

The recent developments in unified gauge theories of weak and electromagnetic interactions¹⁻⁷ have already been fruitful in focusing attention on the experimental question of the existence of leptonic⁸ and hadronic⁹ neutral currents. Such currents arise because in some models^{1,2,7} a neutral heavy boson Z^0 must exist in addition to charged intermediate bosons W^\pm . In other models^{4,5,6}, no neutral currents are needed, but additional heavy leptons are required (along, probably, with "charmed" heavy hadrons as well). It is probable that in any renormalizable theory of weak and electromagnetic interactions either neutral Z 's or heavy leptons, or both, will be required. This assertion gains credibility when one considers the process $e^+e^- \rightarrow W^+W^-$, which proceeds via the diagrams of Figure 1.

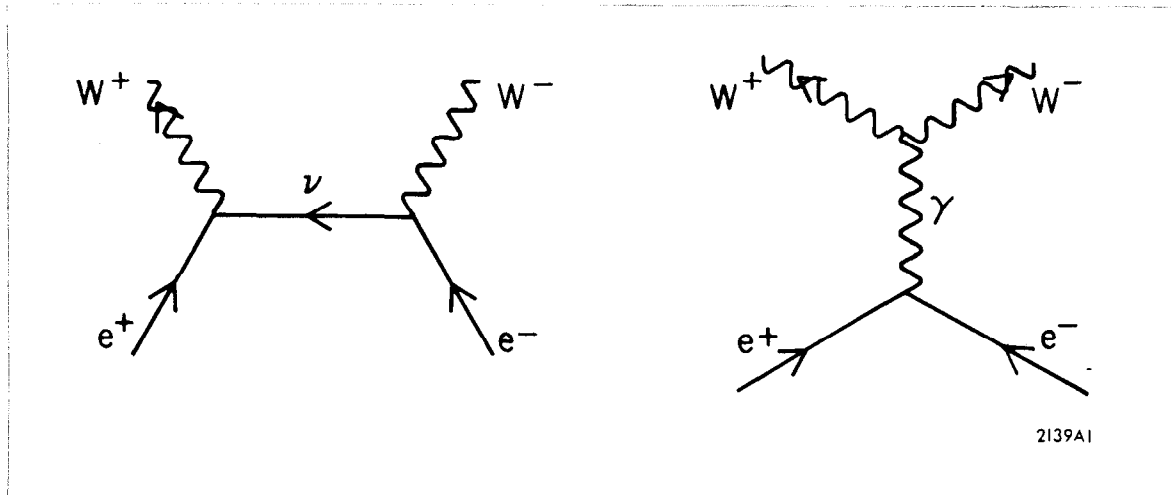

Figure 1
Diagrams for the process $e^+e^- \rightarrow W^+W^-$

The high-energy behavior of this amplitude in the $J = 1$ partial wave violates the unitarity condition.¹⁰ In a renormalizable theory with small coupling constants, phase shifts must not grow large, except near narrow resonances. In the present case, there appears to be no alternative to large phase shifts other

than introduction of additional particle-exchange poles into the amplitude, as in Figure 2. The s-channel poles have the quantum numbers of the Z^0 , and t- or u-channel poles have the quantum numbers of neutral or doubly charged heavy leptons, probably with spin $\frac{1}{2}$ (in order to keep higher order processes renormalizable).

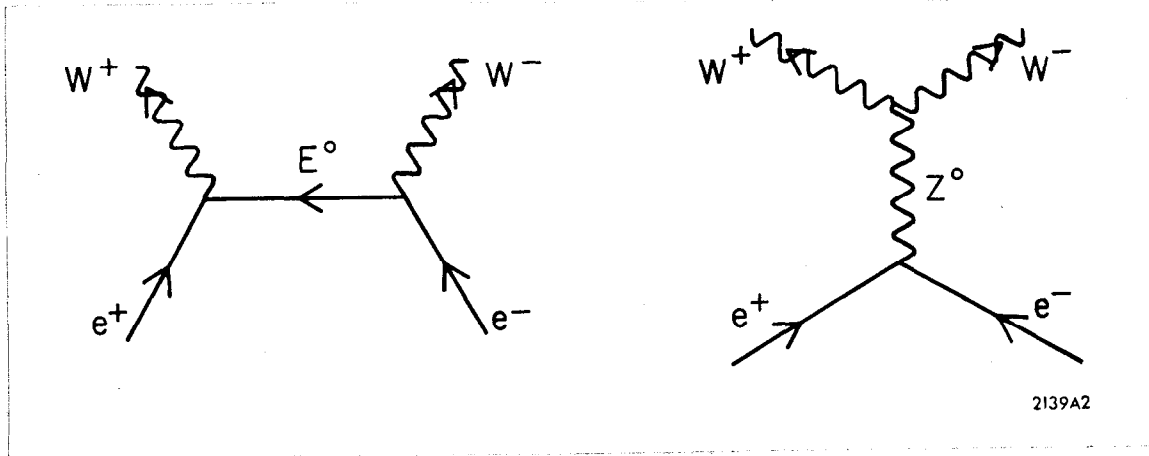

Figure 2

Additional contributions to the process $e^+e^- \rightarrow W^+W^-$

Thus, most renormalizable theories will contain heavy leptons, and in any case it is of interest to understand the phenomenology of such particles. It is the purpose of this paper to outline observable consequences of the existence of such heavy leptons in the context of these renormalizable gauge theories. The particles we consider are E^+ and E^0 (M^+ and M^0), $J = \frac{1}{2}$ fermions with the same lepton number assignment as the e^- (μ^-). In Section II we consider the decay modes of such particles, and in Section III we discuss their production. We leave the strength of their couplings to W^\pm and Z as free parameters; these parameters are calculated for six typical theories in the Appendix. Section IV contains a summary of our conclusions.

II. DECAY MODES

We write the fermion current with which the intermediate vector boson interacts in the form

$$J_\mu = \bar{\psi}_f \left[\left(\frac{g_R + g_L}{2} \right) \gamma_\mu + \left(\frac{g_R - g_L}{2} \right) \gamma_\mu \gamma_5 \right] \psi_i \quad (2.1)$$

where $g_{R,L}$ are of course different for different transitions. When neutrinos (ν_e or ν_μ) are involved $g_R = 0$ and in the transitions $\nu_e(\nu_\mu) \longleftrightarrow e^-(\mu^-) + W^+$,

$$\frac{g_L^2}{4} = g^2 = \frac{M_W^2 G_F}{\sqrt{2}} .$$

We make the approximation $m_e = m_\mu = 0$ so that all the results quoted for E decay can be directly transcribed to M decay. We shall assume that $M_W, M_Z > M_E, M_M$. If this is not the case, E(M) will decay rapidly into lepton + W or Z. The requirement that the M contribution does not spoil the agreement between theory and experiment for $(g-2)_\mu$ constrains the masses in some cases.¹¹ The diagrams in Figure 3 are the only ones which can make appreciable contributions.

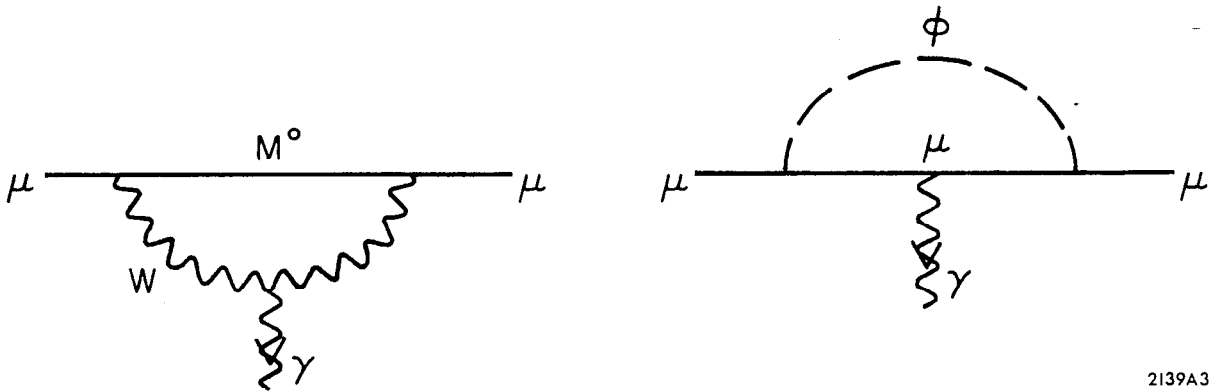

2139A3

Figure 3

Diagrams which may make important contributions to $(g-2)_\mu$

The diagram involving an intermediate W gives¹¹

$$a_{\mu} = \frac{\text{Re } g_L^* g_R}{64 \pi^2 g^2} \frac{G_F M_{\mu} M_{M^0}}{\sqrt{2}} \left[\frac{3}{(1-r)^2} \left\{ 1 - 3r - \frac{2r^2 \log r}{1-r} \right\} + 1 \right] + O\left(\frac{M_{\mu}}{M}\right) \quad (2.2)$$

where

$$r = \left(\frac{M_{M^0}}{M_W} \right)^2 .$$

In all the theories catalogued in the appendix except the Georgi-Glashow theory⁴ either $g_L = 0$ or $g_R = 0$ and the second diagram makes a negligible contribution because the $\mu - \phi$ coupling is small. In the Georgi-Glashow theory, however, the demand that $|a_{\mu}| \leq 0.9 \times 10^{-6}$ does constrain the masses considerably.¹¹

After giving formulae for the decay widths to various channels¹²⁻¹⁹ we will summarize the results for branching ratios and for $\Gamma(\text{tot})$ at the end of this section.

Leptonic Decays

If $M_{E^+} > M_{E^0}$, we find:

$$\frac{\Gamma(E^+ \rightarrow E^0 e^+ \nu_e)}{\Gamma(\mu^- \rightarrow \nu_{\mu} e^- \bar{\nu}_e)} = \left(\frac{M_{E^+}}{M_{\mu}} \right)^5 \left[\frac{|g_R|^2 + |g_L|^2}{4g^2} f_1(z) + \frac{2 \text{Re } g_R^* g_L}{4g^2} f_2(z) \right] \quad (2.3)$$

where

$$z = M_{E^0}/M_{E^+}$$

and

$$\begin{aligned} f_1(z) &= (1-z^4)(z^4 - 8z^2 + 1) + 24z^4 \ln(1/z) \\ f_2(z) &= 4z(1-z^2)^3 - 6z(1+z^2)(1-z^4 - 4z^2 \ln(1/z)) . \end{aligned} \quad (2.4)$$

Here, and below, the same formulae obviously describe the decays $E^0 \rightarrow E^+ + \dots$ if $M_{E^0} > M_{E^+}$ with $z \rightarrow 1/z$. We have assumed $M_W^2 \gg (M_{E^+} - M_{E^0})^2$ in Eq. (2.3) and neglected the momentum dependence of the W propagator. The processes $E^+ \rightarrow E^0 \mu^+ \nu_\mu$, $E^+ \rightarrow \nu_e \mu^+ \nu_\mu$, $E^0 \rightarrow e^- e^+ \nu_e$, and $E^0 \rightarrow e^- \mu^+ \nu_\mu$ are obviously also described by Eq. (2.3). However, for $E^+ \rightarrow e^+ \nu_e \nu_e$, the right-hand side of Eq. (2.3) must be multiplied by 2 to account for the identity of the two neutrinos in the final state.

Hadronic Decay Models

Continuum Contributions

We define the spectral functions ρ_1, ρ_2 for the weak current $\mathcal{J}_\mu^W = g^{-1} J_\mu^W$ by

$$\begin{aligned} \sum_F \langle 0 | \mathcal{J}_\mu^{W^+}(0) | F \rangle \langle F | \mathcal{J}_\nu^W(0) | 0 \rangle (2\pi)^3 \delta^4(q - p_F) = \\ = \rho_1(q^2) (q_\mu q_\nu - q^2 g_{\mu\nu}) + \rho_2(q^2) q_\mu q_\nu \end{aligned} \quad (2.5)$$

where the sum is over all hadronic states. Then, if the hadrons have invariant mass \sqrt{t} :

$$\begin{aligned} \frac{d\Gamma}{dt} (E^+ \rightarrow E^0 + \text{hadrons}) = \frac{G^2 M_{E^+}^3}{16\pi} \frac{1}{\left(1 - \frac{t}{M_W^2}\right)^2} \\ \times \sqrt{\left(1 - z^2 - \frac{t}{M_{E^+}^2}\right)^2 - \frac{4z^2 t}{M_{E^+}^2}} \\ \times \left[\frac{|g_R|^2 + |g_L|^2}{4g^2} g_1(z, t) + \frac{2 \operatorname{Re} g_R^* g_L}{4g^2} g_2(z, t) \right] \end{aligned} \quad (2.6)$$

where

$$\begin{aligned}
g_1(z, t) &= \rho_1(t) \left[(1-z^2)^2 + \frac{t}{M_{E^+}^2} (1+z^2) - \frac{2t^2}{M_{E^+}^4} \right] + \\
&+ \rho_2(t) \left(1 - \frac{t}{M_W^2} \right)^2 \left[(1-z^2)^2 - \frac{t}{M_{E^+}^2} (1+z^2) \right] \\
g_2(z, t) &= -6zt\rho_1(t) + 2zt\rho_2(t) \left(1 - \frac{t}{M_W^2} \right)^2 .
\end{aligned} \tag{2.7}$$

All other decays to the hadronic continuum are special cases of this formula. (In the special case $g_R = 0$, $z = 0$, this result agrees with a formula given by Tsai.¹⁹)

To estimate $\rho_{1,2}$, we invoke the notions of asymptotic chiral symmetry:²⁰

$$\begin{aligned}
\lim_{t \rightarrow \infty} \rho_2(t) &= 0, \\
\lim_{t \rightarrow \infty} \rho_1^{VV}(t) &= \rho_1^{AA}(t)
\end{aligned} \tag{2.8}$$

and asymptotic SU(3):²¹

$$\lim_{t \rightarrow \infty} \frac{\rho_1^{VV}(t)_{I=0}}{\rho_1^{VV}(t)_{I=1}} = \frac{1}{3} . \tag{2.9}$$

Hence we obtain:

$$\lim_{t \rightarrow \infty} \rho_1^{\text{weak}}(t) = \frac{1}{4\pi^2} \lim_{s \rightarrow \infty} \frac{\sigma_{e^+e^- \rightarrow \text{hadrons}}}{\sigma_{e^+e^- \rightarrow \mu^+\mu^-}} . \tag{2.10}$$

It is commonly expected that

$$\lim_{s \rightarrow \infty} \frac{\sigma_{e^+e^- \rightarrow \text{hadrons}}}{\sigma_{e^+e^- \rightarrow \mu^+\mu^-}} = C . \tag{2.11}$$

The Frascati experiments suggest²² $C = 1 - 2$ (for orientation, we note that the conventional three-quark model suggests $C = 2/3$ while three triplet models, of the type which seem to be required to explain $\Gamma(\pi^0 \rightarrow 2\gamma)$, suggest $C = 2$).

If Eq. (2.8) to (2.11) obtain (always assuming $M_W^2 \gg (M_{E^+} - M_{E^0})^2, M_{E^+,0}^2$), then evidently the branching ratios into leptons and hadrons are simply related; e. g.,

$$\frac{\Gamma(E^+ \rightarrow E^0 + \text{hadron continuum})}{\Gamma(E^+ \rightarrow E^0 + e^+ + \nu_e)} = \frac{3}{2} C. \quad (2.12)$$

Furthermore, the momentum spectrum of E^0 in the leptonic process $E^+ \rightarrow E^0 + e^+ + \nu_e$ is also given by (2.7), with $\rho_1 = 1/6 \pi^2, \rho_2 = 0$.

Single Particle Contributions

The important single particle contributions presumably come from $\pi^\pm, \rho^\pm, A1^\pm$. They are described by Eq. (2.6) with

$$\begin{aligned} \rho_1^\rho &= \frac{M_\rho^2}{2\gamma_\rho^2} \delta(t - M_\rho^2) \\ \rho_1^{A1} &= \frac{M_{A1}^2}{2\gamma_{A1}^2} \delta(t - M_{A1}^2) \\ \rho_2^\rho &= \rho_2^{A1} = 0 \\ \rho_1^\pi &= 0 \\ \rho_2^\pi &= f_\pi^2 \delta(t - M_\pi^2). \end{aligned} \quad (2.13)$$

Experimentally²³ $\gamma_\rho^2/4\pi \approx 0.64, f_\pi \approx 0.9 m_\pi$. The (suspect) second Weinberg sum rule²⁴ yields $\gamma_\rho/M_\rho^2 = \gamma_{A1}/M_{A1}^2$.

The Radiative Decay $E^0 \rightarrow \nu \gamma$

The two-body decay mode $E^0 \rightarrow \nu \gamma$, for which the relevant diagrams are shown in Figure 4, might have an appreciable branching ratio. In the theories

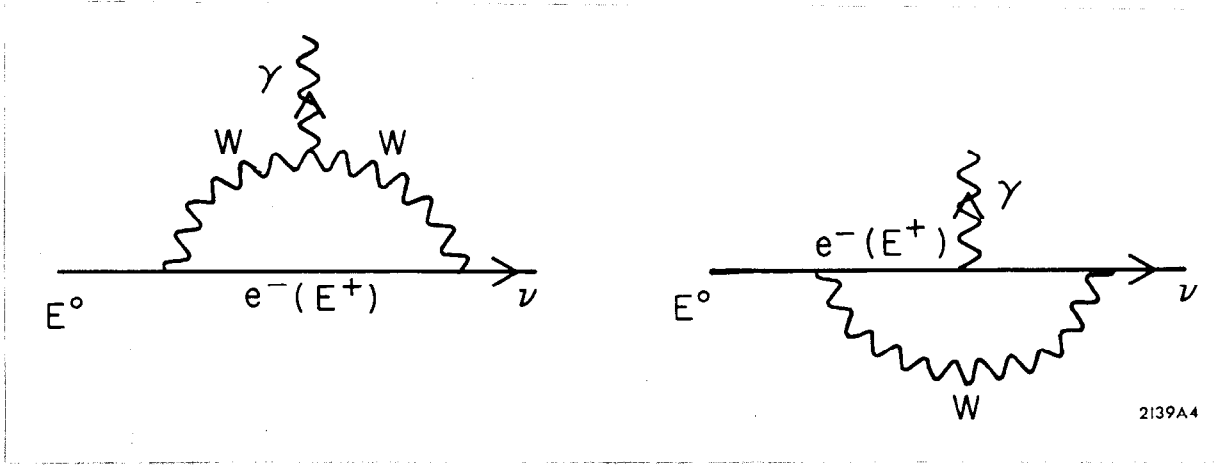

Figure 4

Diagrams contributing to the decay $E^0 \rightarrow \gamma \nu$

catalogued in the appendix, the apparent divergences in these four amplitudes must individually vanish or else cancel each other. A calculation of $\Gamma(E^0 \rightarrow \nu \gamma)$ would be lengthy and model-dependent. We guess:

$$\frac{\Gamma(E^0 \rightarrow \nu \gamma)}{\Gamma(E^0 \rightarrow \pi \nu)} \sim \frac{\alpha}{\pi^3} \left(\frac{M_{E^+}}{f_\pi} \right)^2 \quad (2.14)$$

This can be combined with the results above to yield:

$$\frac{\Gamma(E^0 \rightarrow \nu \gamma)}{\Gamma(E^0 \rightarrow e^+ \mu^- \bar{\nu}_\mu) + \Gamma(E^0 \rightarrow e^+ e^- \bar{\nu}_e)} \sim \frac{6\alpha}{\pi} \quad (2.15)$$

if $g_R(g_L) = 0$ and $g_L^2(g_R^2) = 4g^2$. We conclude that the $\nu \gamma$ decay mode is unlikely to be dominant although it might well be appreciable since Eq. (2.14) could easily be wrong by an order of magnitude or more.

E⁺ Branching Ratios

The easiest cases to consider are the decays $E^+ \rightarrow \nu + \dots$. These decays have previously been considered by Tsai¹⁹ and our results are in agreement with his. The equations above yield the branching ratios plotted in Figure 5 as a function of M_E , where we have calculated the continuum contribution using Eq. (2.11) for finite s with $C = 2$ for $\sqrt{s} > 900$ MeV and $C = 0$ for $\sqrt{s} < 900$ MeV (the appropriate phase space factor smooths out the contribution to Γ) and $\gamma_\rho/M_\rho^2 = \gamma_{A1}/M_{A1}^2$ (unless this is very wrong—which it may be—the $A1$ makes a very small contribution). The value of $\Gamma(E^+ \rightarrow \nu_e + \text{anything})$ obtained with the same assumptions is plotted as a function of M_E in Figure 6.

If $M_{E^+} > M_{E^0}$, we must also consider the decays $E^+ \rightarrow E^0 + \dots$. The results are more model-dependent than those for $E^+ \rightarrow \nu + \dots$, since they depend on the relative magnitude of g_L and g_R . If Eq. (2.8) - (2.11) are correct, the relative importance of the continuum and the leptonic modes is given by Eq. (2.12). The relative importance of the various hadronic modes obviously depends sensitively on z (cf. Eq. (2.7)). This dependence is exhibited in Figure 7 where we have plotted the function

$$S(z, t) = \sqrt{\left(1 - z^2 - \frac{t}{M_E^2}\right)^2 - \frac{4z^2 t}{M_E^2}} \left[\left(1 - z^2\right)^2 + \frac{t}{M_E^2} (1 + z^2) - \frac{2t^2}{M_E^2} \right] \quad (2.16)$$

which modulates the contribution of the spectral function $\rho_1(t)$ to $d\Gamma/dt$ in Eq.

(2.7) if $g_R = 0$ or $g_L = 0$. $\Gamma(E^+ \rightarrow E^0 \mu^+ \nu_\mu) / \Gamma(E^+ \rightarrow \nu_e \mu^+ \nu_\mu)$ may be obtained from Eq. (2.3) if g_R and g_L are known. The functions $f_1(z)$ and $f_2(z)$ (Eq. (2.3)), which determine the dependence of this ratio on g_R and g_L , are plotted in Figure 8.

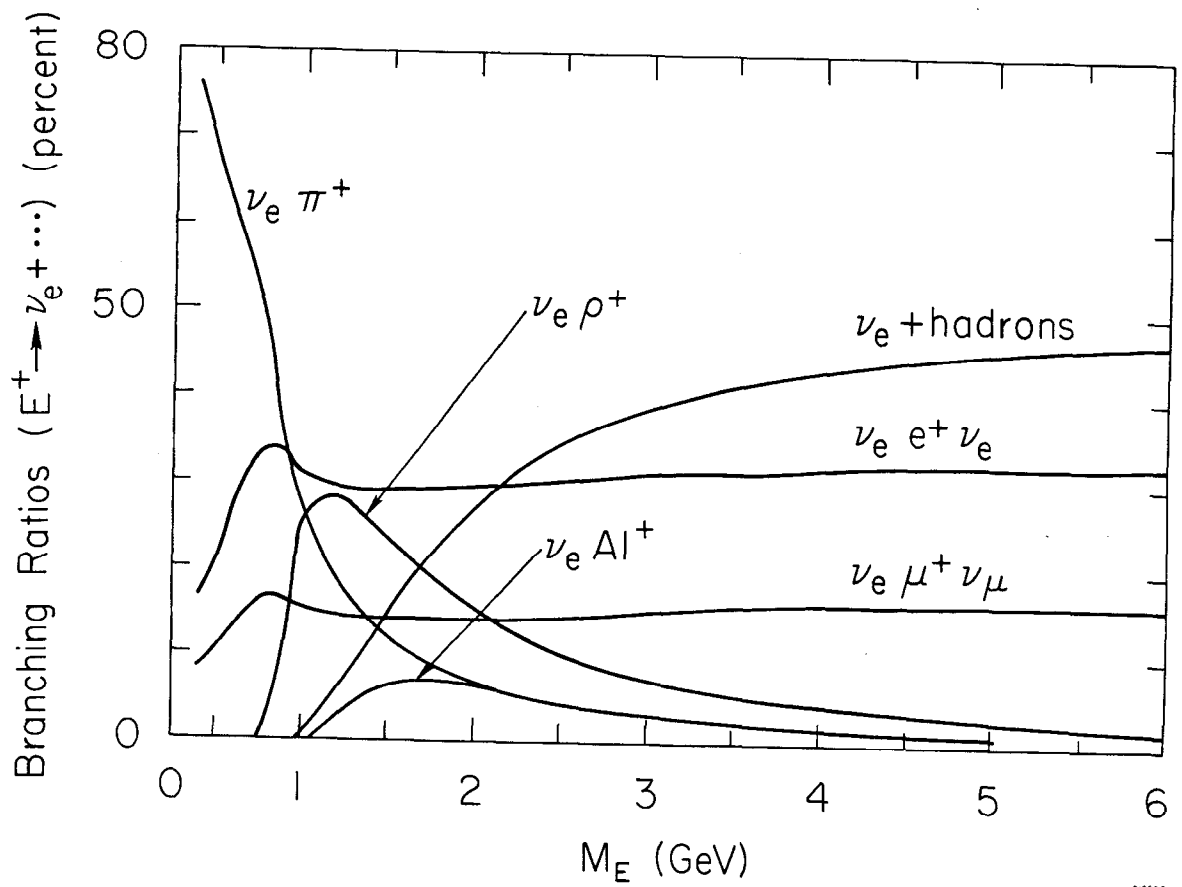

Figure 5

Branching ratios (in percent) for the decays $E^+ \rightarrow \nu_e + \dots$ as a function of M_E with the assumptions discussed in the text.

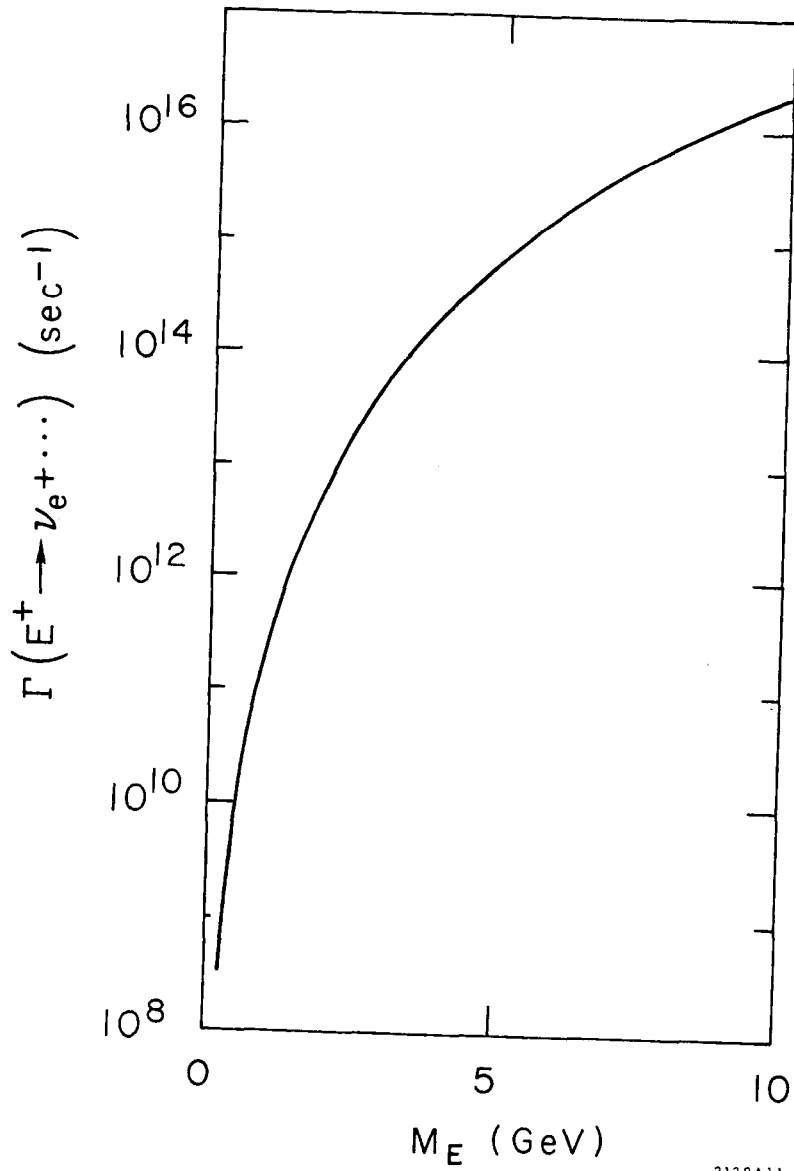

Figure 6
 $\Gamma(E^+ \rightarrow \nu_e + \text{anything})$ in sec^{-1} as a function of M_E with the same assumptions as in Figure 5.

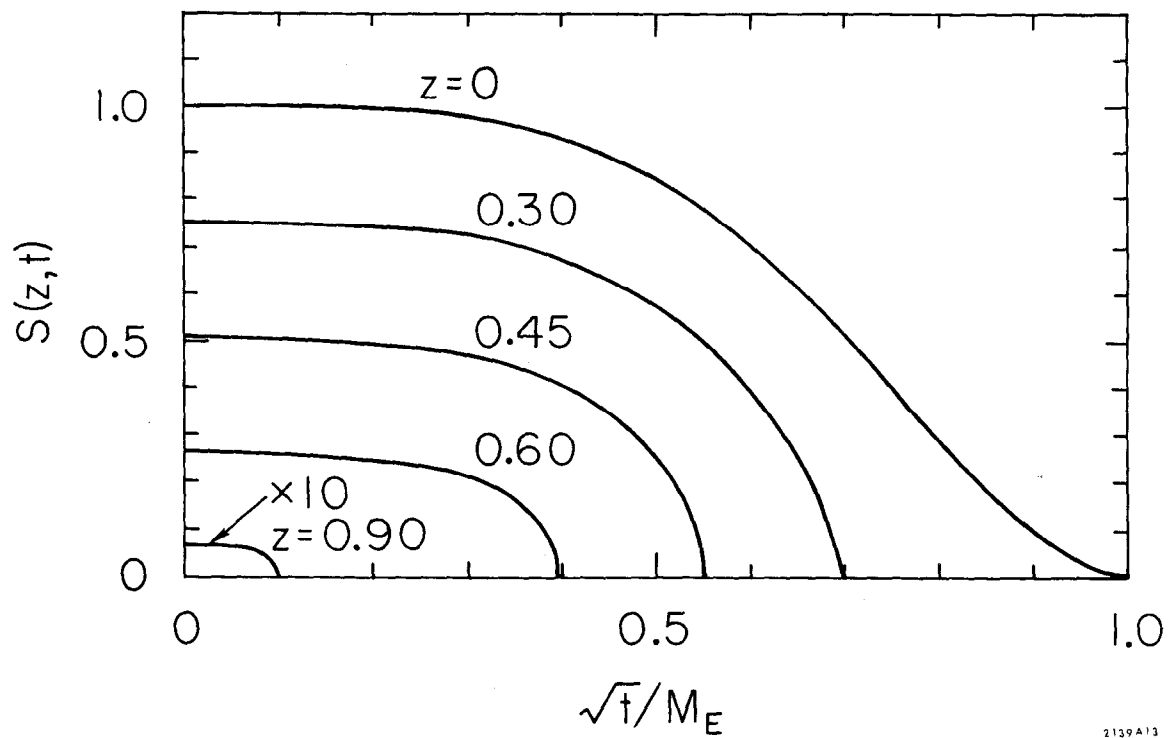
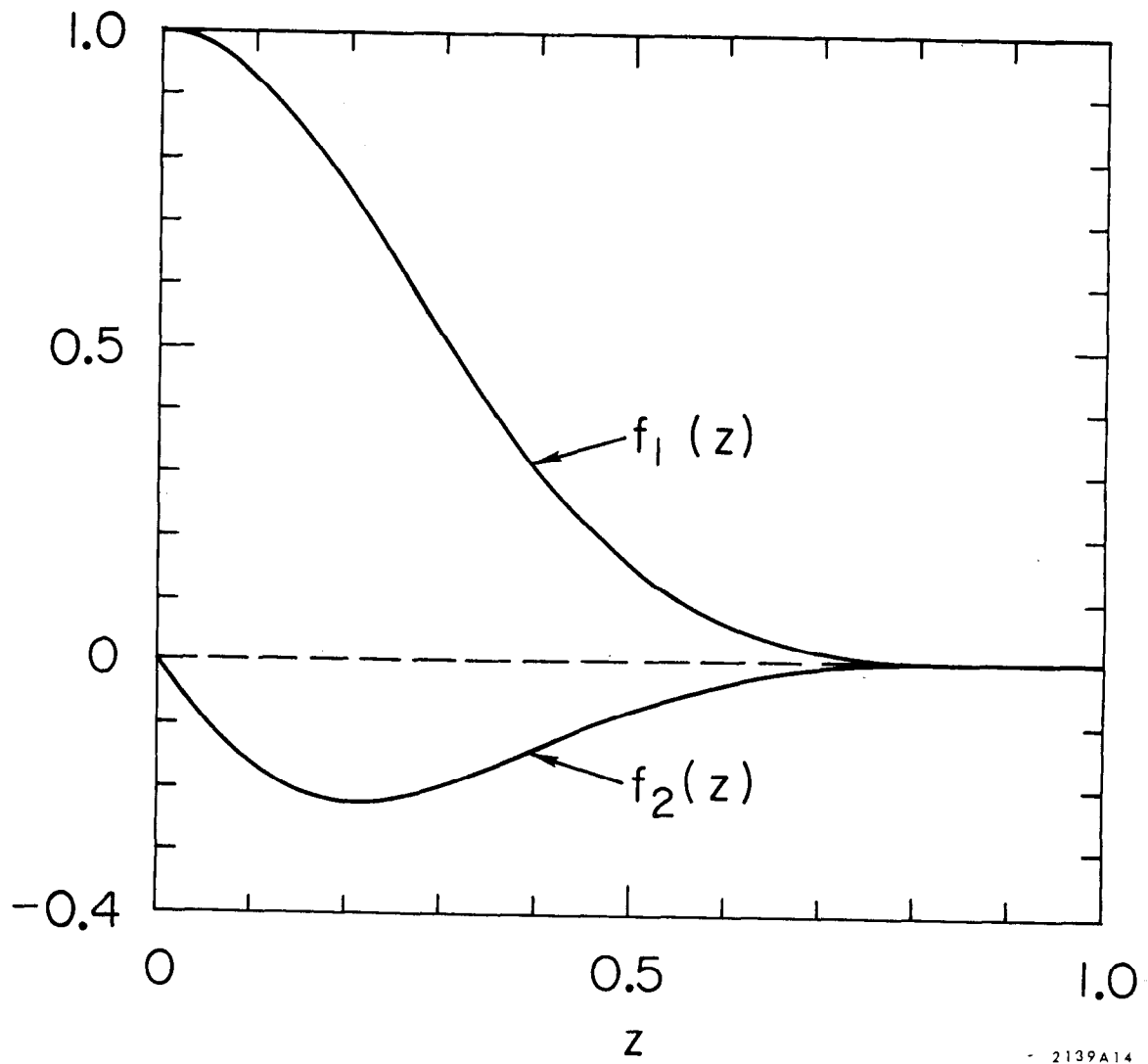

Figure 7

The function $S(z, t)$ (Eq. 2.16), which determines in part the relative importance of various hadronic modes in decays $E^{(\phi)} \rightarrow E^{(\psi)} + \text{hadrons}$, plotted against \sqrt{t}/M_E for various values of z .



2139A14

Figure 8

The functions $f_1(z)$ and $f_2(z)$ (Eq. 2.3) plotted against z .

E⁰ Decays

The branching ratios and widths for the decays $E^0 \rightarrow e^+ + \dots$ depend on g_R and g_L but are probably qualitatively described by Figures 5 and 6 (with the same assumptions). If $M_{E^0} > M_{E^+}$, the discussion of the decays $E^+ \rightarrow E^0 + \dots$ above applies to $E^0 \rightarrow E^+ + \dots$. As discussed above, $\Gamma(E^0 \rightarrow \nu \gamma)$ is very model-dependent but this mode might well be a few percent of the branching ratio.

III. PRODUCTION MECHANISMS

Charged heavy leptons may, of course, be pair-produced by γ -rays or in e^+e^- colliding beams via the one-photon virtual intermediate state. This has been thoroughly discussed by Kim and Tsai²⁵ and we have nothing to add. However, there are various ways to produce the leptons singly:

1. e^-e^+ Colliding Beams

Here the E^0 may be produced via the weak process (Figure 9):

$$e^+e^- \rightarrow \bar{E}^0 + \nu_e \quad (3.1)$$

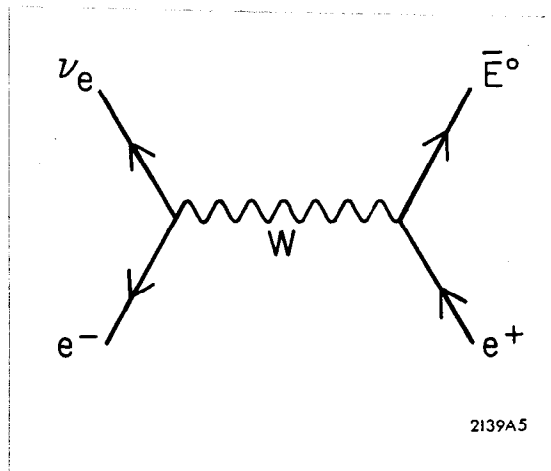

Figure 9

Diagram contributing to the decay $e^+e^- \rightarrow E^0 \nu_e$

While the diagram in Figure 10 would appear possible were a neutral boson Z to exist, none of the theories catalogued in Appendix A gives a non-vanishing $\overline{E^0} \nu_e Z$ coupling.

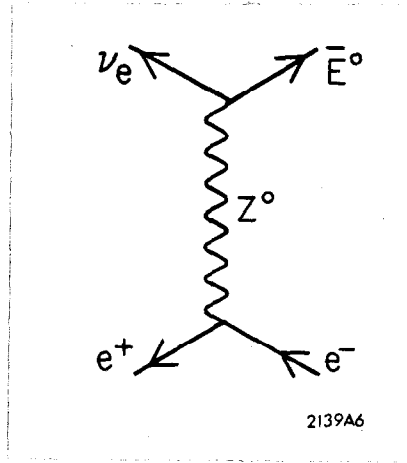

Figure 10

Diagram which might contribute to the decay $e^+e^- \rightarrow \overline{E^0} \nu_e$

The best signature is probably afforded by the decay

$$E^0 \rightarrow e^+ \nu_\mu \mu^- . \quad (3.2)$$

The production cross section is (for $s \ll m_W^2$)

$$\begin{aligned} \frac{d\sigma}{d\Omega}_{\text{cm}} (e^+e^- \rightarrow \overline{E^0} \nu_e) &= \frac{G^2 s}{32 \pi^2} \left(1 - \frac{M_{E^0}^2}{s}\right)^2 \times \\ &\times \left\{ \frac{4|g_R|^2}{g^2} + \frac{|g_L|^2}{g^2} \left[(1 + \cos \theta)^2 + \frac{M_{E^0}^2}{s} \sin^2 \theta \right] \right\} \end{aligned} \quad (3.3)$$

where θ is the cms angle of the neutrino relative to the incident e^- . Upon integration

$$\sigma(e^+e^- \rightarrow \overline{E^0} \nu_e) = \frac{G^2 s}{2 \pi} \left(1 - \frac{M_{E^0}^2}{s}\right)^2 \left[\frac{|g_R|^2}{g^2} + \frac{|g_L|^2}{3g^2} \left(1 + \frac{M_{E^0}^2}{2s}\right) \right] \quad (3.4)$$

For typical theories, the factor in brackets is 0(1), but could be much larger. For example, in the model of Georgi and Glashow⁴ (Appendix A, Model 6), the square bracket is

$$\approx \left[\frac{|g_R|^2}{g^2} + \frac{1}{3} \frac{|g_L|^2}{g^2} \right] \approx \frac{\left[1 + \frac{1}{3} \cos^2 \alpha \right]}{\sin^2 \alpha} = \left[\frac{4}{3} \left(\frac{53 \text{ GeV}}{M_W} \right)^2 - \frac{1}{3} \right] \lesssim 150 \quad (3.5)$$

where the limit $m_W \gtrsim 5 \text{ GeV}$ provides the upper bound. In Figure 11 is plotted σ_{tot} vs E_{beam} assuming arbitrarily $\left[g_R^2 + \frac{1}{3} g_L^2 \right] = g^2$. We see that the next generation of $e^+ e^-$ rings may be sensitive to E^0 masses of order 2 GeV.

2. Neutrino Production

The reaction

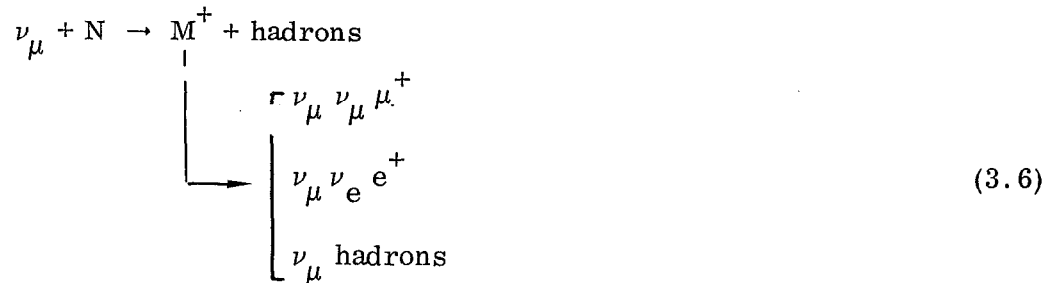

provides a good way of searching for M^+ , having in all cases an excellent signature. The cross section can be directly related to the reaction



the same structure functions W_1, W_2, W_3 , etc., occurring. The additional structure functions W_4, W_5 , whose contribution vanishes in the limit of vanishing lepton mass will be of significance in M^+ production; indeed one of the useful by-products of heavy-lepton production processes could be measurement of W_4 and W_5 . However, in the absence of any evidence for the existence of heavy leptons, it is sufficient to use simple-minded parton model estimates for the

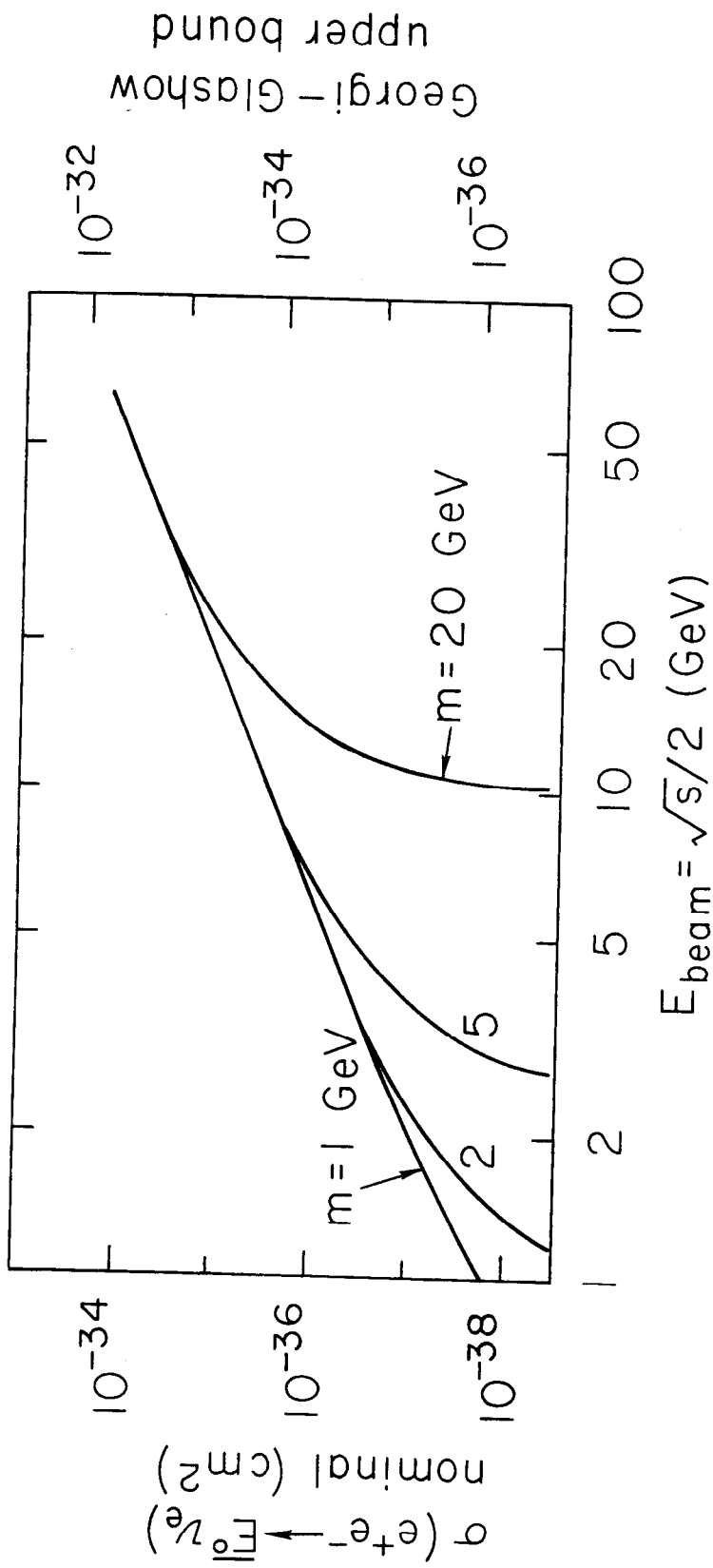

2139810

Figure 11

$\sigma(e^+e^- \rightarrow \bar{\nu}_e \nu_e^0)$ as a function of the beam energy. The left-hand scale was obtained assuming $\left[g_R^2 + \frac{1}{3} g_L^2 \right] = g^2$. The right-hand scale follows from the bound in Eq. (3.5).

production cross sections. A short calculation gives, in the deep inelastic limit,

$$\frac{\sigma(\nu_{\mu} n \rightarrow M^+ + \text{hadrons}) + \sigma(\nu_{\mu} p \rightarrow M^+ + \text{hadrons})}{\sigma(\nu_{\mu} n \rightarrow \mu^- + \text{hadrons}) + \sigma(\nu_{\mu} p \rightarrow \mu^- + \text{hadrons})} = \left(\frac{g^{M^+}}{g^{\mu^-}} \right)^2 \Phi \left(\frac{s}{M^2} \right) \quad (3.8)$$

where g^{M^+}/g^{μ^-} = ratio of weak coupling constants* for $M^+ \rightarrow \nu W$ and $\mu^- \rightarrow \nu W$,
and

$$\Phi(s/M^2) = \frac{\int_0^1 \left(1 - \frac{M^2}{sx}\right)^2 \left[f(x) + \frac{1}{3} \left(1 + \frac{M^2}{sx}\right) \bar{f}(x) \right] dx}{\int_0^1 \left(f(x) + \frac{1}{3} \bar{f}(x) \right) dx} \quad (3.9)$$

where $f(x)$ ($\bar{f}(x)$) is $2x$ times the momentum distribution function for isospin $1/2$ partons (antipartons) in a nucleon averaged over p and n . If we assume $\bar{f} \ll f$ (which is true in most models for x near one) and put $f(x) \sim \nu W_2^{ep}$, then Φ can be calculated and the result is sketched in Fig. 12. It must be emphasized that Figure 12 is only a rough approximation (which could be improved if the parton model turns out to work in ordinary neutrino interactions).

Assuming only (1) neglect of $|\Delta S| = 1$ processes and (2) isovector $\Delta S = 0$ currents, the function $\Phi \rightarrow 1$ as $s/M^2 \rightarrow \infty$. Hence Φ is model insensitive for s/M^2 large. From Figure 12 we may probably conclude that $M_{M^+} > 1$ GeV. In the CERN heavy-liquid bubble chamber experiment there were observed over 100 events with $E_{\nu} > 4$ GeV. Were M^+ to exist with mass ~ 1 GeV, there should

*In the models considered in Appendix A, this ratio is unity.

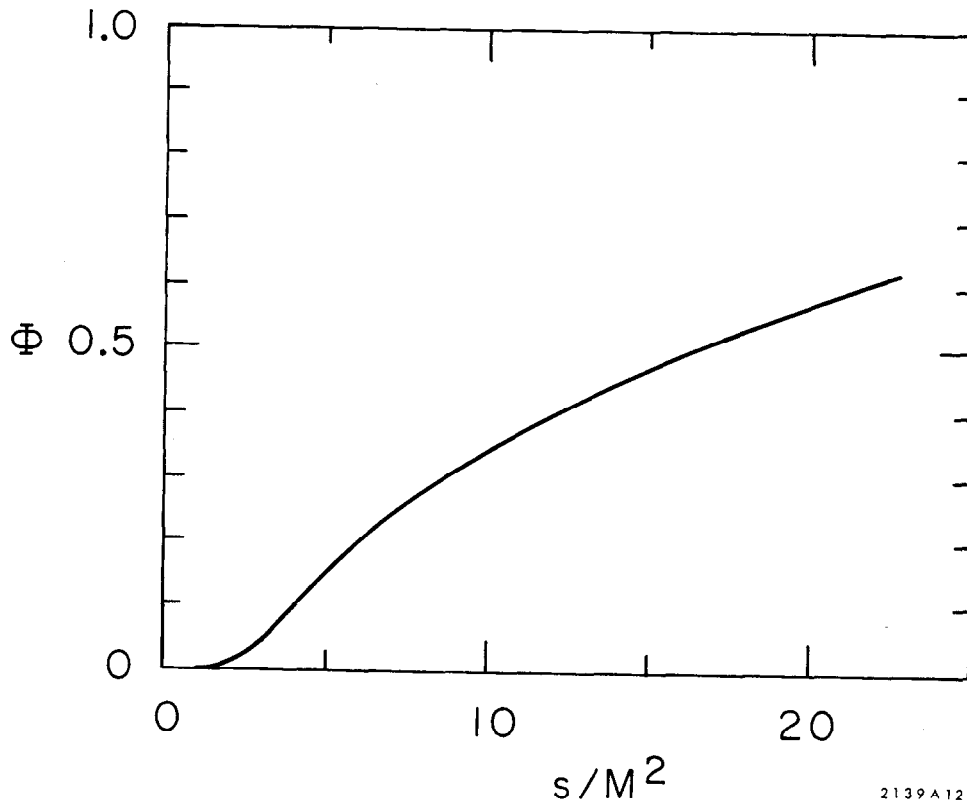

Figure 12

The function Φ (Eq. 3.8), which determines the ratio of M^+ to μ^- production in $\nu_\mu + A$ collisions, as a function of S/M_M^2 assuming $\bar{f} = 0$, $f \sim \nu W_2^{\text{ep}}$. This curve is of course only approximate.

have been $\gtrsim 25 M^+$ production events as well. Were the M^+ to have a mass ~ 1.5 GeV, this number would drop to ~ 5 , probably consistent with the data.²⁶

Similar considerations apply to production of M^- by $\bar{\nu}_\mu$ or E^\pm by $\nu_e, \bar{\nu}_e$. No model in Appendix A predicts E^0 or M^0 production by neutrinos except in higher orders of g and e .

On the basis of Figure 12 we conclude that neutrino experiments at NAL will be able to set mass limits of at least 5 GeV (but almost certainly not more than 10 GeV) on heavy leptons of the type considered by us.

3. Production by Charged Leptons

The reactions

$$\begin{array}{l}
 \mu^+ + N \rightarrow M^0 + \text{hadrons} \\
 \left[\begin{array}{l} \mu^+ \mu^- \bar{\nu}_\mu \\ \mu^+ e^- \bar{\nu}_e \\ \mu^+ + \text{hadrons} \end{array} \right. \\
 \\
 e^+ + N \rightarrow E^0 + \text{hadrons} \\
 \left[\begin{array}{l} e^+ \mu^- \bar{\nu}_\mu \\ e^+ e^- \bar{\nu}_e \\ e^+ + \text{hadrons} \end{array} \right.
 \end{array} \tag{3.10}$$

and similar antiparticle reactions occur again with cross sections comparable to, and possibly larger than, neutrino cross sections at comparable beam energies.

The estimate for unpolarized incident muons is

$$\frac{\sigma(\mu^- n \rightarrow M^0 + \text{hadrons}) + (n \rightarrow p)}{\sigma(\nu_\mu n \rightarrow \mu^- + \text{hadrons}) + (n \rightarrow p)} = \frac{1}{2} \left[\frac{g_L^2}{g^2} \Phi\left(\frac{s}{M^2}\right) + \frac{g_R^2}{g^2} \bar{\Phi}\left(\frac{s}{M^2}\right) \right] \tag{3.11}$$

$$\frac{\sigma(\mu^+ n \rightarrow M^0 + \text{hadrons}) + (n \rightarrow p)}{\sigma(\nu_\mu n \rightarrow M^0 + \text{hadrons}) + (n \rightarrow p)} = \frac{1}{2} \left[\frac{g_R^2}{g^2} \Phi\left(\frac{s}{M^2}\right) + \frac{g_L^2}{g^2} \bar{\Phi}\left(\frac{s}{M^2}\right) \right] \tag{3.12}$$

where

$$\bar{\phi}\left(\frac{s}{M^2}\right) = \frac{\int_0^1 \left(1 - \frac{M^2}{s x}\right)^2 \left[\frac{1}{3} \left(1 + \frac{M^2}{s x}\right) f(x) + \bar{f}(x)\right] dx}{\int_0^1 \left[f(x) + \frac{1}{3} \bar{f}(x)\right] dx} \quad (3.13)$$

$\bar{\phi}$ is expected to be smaller than ϕ , but not less than by a factor of 3. In particular, as $s/M^2 \rightarrow \infty$

$$\frac{\bar{\phi}(s/M^2)}{\phi(s/M^2)} \rightarrow \frac{\sigma_{\text{tot}}(\bar{\nu} n) + \sigma_{\text{tot}}(\bar{\nu} p)}{\sigma_{\text{tot}}(\nu n) + \sigma_{\text{tot}}(\nu p)} \quad (3.14)$$

High-energy muon beams from proton accelerators have generally a high degree of longitudinal polarization (predominantly right-handed μ^- and left-handed μ^+). Under these circumstances, the right-hand sides of Eq. (3.11) and (3.12) evidently should be replaced by $g_R^2 \bar{\phi}(s/m^2)$ and $g_R^2 \phi(s/m^2)$, respectively. Thus the search is probably best made with μ^+ beams. Inspection of Appendix A shows that in three theories $g_R^2 > 1$; in the Georgi-Glashow model, $g_R^2 \approx (54 \text{ GeV}/m_W)^2 \approx 100$. Thus for 100 GeV fully polarized μ^+ incident

$$4 \times 10^{-37} \text{ cm}^2 \lesssim \sigma(\mu^+ N \rightarrow M^0 + \text{hadrons}) \lesssim 2.5 \times 10^{-35} \text{ cm}^2 \quad (3.15)$$

provided $M_{M^0} < 4 \text{ GeV}$. An experiment using the NAL muon beam looks possible but extremely difficult.

Similar estimates apply to \bar{M}^0 production by μ^- and E^0 (\bar{E}^0) production by e^+ (e^-). We are unable to assess the feasibility of searching for E^0 and \bar{E}^0 using e^\pm beams; there are evidently difficult background problems.

4. Production in Hadron-Hadron Collision

The production of heavy charged lepton pairs in hadron-hadron collisions is evidently related to μ -pair production in a simple way:

$$\frac{\frac{d\sigma}{dQ^2} (pp \rightarrow L^+ L^- + \text{hadrons})}{\frac{d\sigma}{dQ^2} (pp \rightarrow \mu^+ \mu^- + \text{hadrons})} = \left(1 - \frac{4M_L^2}{Q^2}\right)^{\frac{1}{2}} \left(1 + \frac{2M_L^2}{Q^2}\right) \quad (3.16)$$

where Q^2 is the mass of the lepton pair. In the same way

$$\frac{\frac{d\sigma}{dQ^2} (pp \rightarrow E^+ \bar{\nu}_e + \text{hadrons})}{\frac{d\sigma}{dQ^2} (pp \rightarrow e^- \bar{\nu}_e + \text{hadrons})} \approx \frac{g_{E^+ \nu_e}^2}{g^2} \left(1 + \frac{M_L^2}{2Q^2}\right) \left(1 - \frac{M_L^2}{Q^2}\right)^2 \quad (3.17)$$

with similar formulae for E^0 , \bar{E}^0 , M^0 , and \bar{M}^0 production. At extremely high energies (such as the ISABELLE 200-GeV p-p rings under present study), the weak process $pp \rightarrow e^- \bar{\nu}_e + \text{hadrons}$ may be observable, especially if the scaling behavior suggested by the Drell-Yan²⁷ parton annihilation mechanism turns out to be correct. In such a case Berman has argued²⁸ that it should be feasible to detect the heavy-lepton production as well. However, at present energies, the small cross sections and difficult backgrounds do not provide much encouragement.

However, one must keep in mind that most of the plausible generalizations of these classes of gauge theories to include hadrons require the existence of new additive quantum numbers (charm) and new classes of hadrons which may be produced strongly.

V. CONCLUSIONS

In this paper we have only considered heavy leptons with the same lepton numbers as the electron and muon. For a discussion of other possibilities²⁹ we refer to a recent paper by Perl³⁰ in which previous experimental and theoretical work on heavy leptons is reviewed. We have kept coupling constants and masses fairly general and we hope that our formulae will therefore expedite the task of deducing observable consequences for a large class of theories; special cases of most of our results are already in the literature. To summarize:

Branching ratios. In common with other authors,¹² we find that, according to currently popular ideas, the branching ratio into leptons should be $\sim 50\%$. This leads to spectacular signatures in events such as

$$\begin{array}{l}
 e^+ e^- \rightarrow M^+ M^- \\
 \left. \begin{array}{l} \bar{\nu}_\mu \mu^- \bar{\nu}_\mu \\ \bar{\nu}_\mu e^- \bar{\nu}_e \\ \bar{\nu}_\mu + \text{hadrons} \end{array} \right\} \\
 \left. \begin{array}{l} \nu_\mu \mu^+ \nu_\mu \\ \nu_\mu e^+ \nu_e \\ \nu_\mu + \text{hadrons} \end{array} \right\}
 \end{array}$$

$$\begin{array}{l}
 \nu_\mu + N \rightarrow M^+ + \text{hadrons} \\
 \left. \begin{array}{l} \nu_\mu e^+ \nu_e \\ \nu_\mu \mu^+ \nu_\mu \\ \nu_\mu + \text{hadrons} \end{array} \right\}
 \end{array}$$

In addition to the apparent failure of conventional conservation laws, these events would also be distinguished by an apparent failure of transverse momentum

conservation. Furthermore, in processes such as

$$\nu_{\mu} + N \rightarrow \mu^{+} + (\nu_{\mu} + \nu_{\mu} + \text{hadrons})$$

the E_{ν} distribution at fixed ν and q^2 (with $q = k_{\nu_{\mu}} - k_{\mu^{+}}$) would indicate "non-locality"³¹ and in addition, the $\nu - q^2$ distribution would be very different³² from that observed in the ordinary process:

$$\bar{\nu}_{\mu} N \rightarrow \mu^{+} + \text{hadrons} .$$

Production Cross Sections. Undoubtedly the cleanest way to produce charged heavy leptons is in $e^{+}e^{-}$ colliding beams which can set limits close to the beam energy (see, e.g., Figure 3 of Reference 30). Thus an improved SPEAR could set limits of ~ 4.5 GeV in a few years. Pair-production experiments using photon beams at NAL will probably be able to set mass limits in the same range (see Figure 4 of Reference 30, taken from Reference 25). According to our discussion in Section III, the neutrino beams at NAL may be able to do slightly better. Neutral heavy leptons are probably hard to produce (except as decay products if $M^{+} > M^0$), although $e^{+}e^{-}$ colliding beams may be able to set quite good limits if the optimistic right-hand scale in Figure 11 is relevant. It may be possible to search for neutral leptons using the muon beam at NAL, as discussed in Section III.

Appendix A

In this appendix we outline several gauge theories of weak and electromagnetic interactions employing the Higgs mechanism. We fear that none of them in the form presented will turn out to correspond to the real world, but it may possibly be that general features shared by these theories or special features exhibited by one or another of them may survive. To that end perhaps it is helpful to have a statistically sizable sample.

We shall not go into any detail, and will not even write down the full Lagrangians for the theories, it being easier to describe what to do than to quote the answer. The results relevant for our considerations in the preceding section are supplied in Table I. To the reader unexposed to theories of this type, we recommend Higgs's classic paper³³ and the subsequent papers on Weinberg's model² as a prerequisite to this section. Once Weinberg's model is understood, there should be no difficulty in reconstructing the models given here, which for the most part are straightforward (i. e., unimaginative) generalizations of Weinberg's example.

The ingredients of theories of this class are

- (a) A set of $J = 1$ Yang-Mills gauge fields.
- (b) A set of $J = 0$ fields which form a representation of the gauge group.
- (c) A set of 2-component massless spin $1/2$ fields which also form a representation of the gauge group.

A recipe for making renormalizable unified theories of weak and electromagnetic interactions is (once given the basic idea) then not difficult:

1. Choose the gauge group. In all but one case the choice for us is $SU(2) \times U(1)$; the exceptional case is the Georgi-Glashow model⁴ where the gauge group is $SU(2)$, the gauge particles being W^+ , W^- , and photon A . In the other cases

the gauge fields are a triplet W^+ , W^- , W^0 , and a singlet B^0 . The W^0 and B^0 are mixed by interactions to be described below and become the photon A and a neutral heavy $J = 1$ boson Z .

2. Choose the representation of the $J = 0$ Higgs fields, including the charge assignment. In our case this will be either a complex doublet $\phi = \begin{pmatrix} \phi^0 \\ \phi^- \end{pmatrix}$, or a triplet ϕ or in one case (the Glashow-Georgi model) a self-conjugate quartet (triplet \oplus singlet), used in order to reduce the magnitude of the credibility gap separating that model from reality.

3. Choose the representation of the spin 1/2 chiral 2-component fields. We limit ourselves to $I = 0, 1/2, 1$ multiplets. Evidently e_L^- and ν_e must lie in either an $I = 1/2$ or an $I = 1$ multiplet; e_R^- can be in either a singlet, spinor, or vector representation. This gives six basic combinations to consider and explains why there are six theories that we study; they are the simplest examples of each of these options we can find. We shall assume conservation of muon number and electron number; consequently it is sufficient to study the electron system in isolation and then generalize straightforwardly to the muon system. Generalizations to hadrons are also possible for all these models, most conveniently using the $SU(4)$ ideas of Glashow, Iliopoulos, and Maiani,³⁴ and are discussed in Appendix B.

4. Couple the gauge fields invariantly to Higgs fields and fermion fields. Thus in the free Lagrangians of Higgs fields ϕ one makes the gauge invariant replacement

$$i \frac{\partial \phi^a}{\partial x_\mu} \rightarrow i \frac{\partial \phi^a}{\partial x_\mu} - g T_{abc} \phi^b W_\mu^c - g' Y B_\mu \phi^a$$

where T_{abc} is the appropriate isotopic-spin matrix and Y is the hypercharge (mean value of the electric charge of the irreducible multiplet ϕ). g and g' are

independent dimensionless coupling constants. This replacement is also made in the free Fermion Lagrangian.

5. Couple the Higgs fields ϕ invariantly and renormalizably to themselves. This means nonderivative ϕ^2 , ϕ^3 , and ϕ^4 couplings only. Hypercharge and isospin conservation then imply charge conservation as well.

6. Choose these couplings such that the classical interaction Hamiltonian of the Higgs fields is a minimum when a neutral Higgs field ϕ^0 has a nonvanishing value $\langle \phi_0 \rangle$. That is, one demands spontaneous breakdown à la Goldstone, but not a breakdown of electric charge conservation.

7. Couple the Higgs field invariantly and renormalizably to the fermions. This means only couplings of the form (suppressing internal indices)

$$\bar{\psi}_L \psi_R \phi + \text{h.c.}$$

8. Rewrite the Lagrangian in terms of the displaced field $\phi' = \phi - \langle \phi \rangle$ and proceed with quantization. Lo, the new Lagrangian will have the properties:

(a) It is at least almost renormalizable.^{3,35}

(b) Some intermediate bosons obtain a mass, from the term

$$\frac{1}{2} (\partial_\mu \phi - g W_\mu \phi)^2 \rightarrow \frac{1}{2} g^2 W^2 \langle \phi^2 \rangle + \dots$$

(c) Some fermions get mass, from the term $\bar{\psi}_L \psi_R \langle \phi \rangle$.

(d) At least one massless boson remains, which can be identified in all respects as a photon A. Evidently successful design of the theory requires this to be the only massless boson. This does not seem to be a practical difficulty if one allows a proliferation of Higgs fields.

(e) By gauge transformations, some of the scalar fields may be eliminated; they essentially become the longitudinal degrees of freedom of the massive vector bosons. Thus the number and charge assignments

of these "spurious" scalar Higgs particles are in one-to-one correspondence with the massive gauge bosons.

We now outline what happens when this procedure is followed for six typical theories.

I. Weinberg's model² (the 2-1 model)

Here one starts with a triplet + singlet of gauge bosons as described above, a Higgs doublet (ϕ^0, ϕ^-), a left-handed doublet $\psi_L = \begin{pmatrix} \nu_e \\ e^- \end{pmatrix}_L$ and a singlet $\psi_R = e^-_R$. The spinor fields ψ_L and ψ_R are coupled to ϕ , with coupling constant proportional to m_e . Three of the four Higgs degrees of freedom are removed by gauge-transformation; the remaining degree of freedom is the neutral hermitian component feebly coupled to the electron with strength em_e/m_W . The only free parameters are m_ϕ and the mixing angle of W^0 and B. The couplings of fermions to Z, B and the ratio m_W/m_Z are tabulated in Table I.

II. The model of Lee,⁵ Prentki and Zumino⁶ (the 3-1 model)

Here the $J = 1$ boson structure is the same as before (W^\pm, A, Z) but the left-handed fermion doublet is replaced by a triplet

$$\psi_L = \begin{pmatrix} E^+ \\ \nu_e \\ e^- \end{pmatrix}_L$$

of zero hypercharge along with two singlets $\psi_R = e^+$ and $\tilde{\psi}_R = E^-$ of hypercharge ± 1 . In order to produce the e and E mass, the Higgs field must be a triplet of hypercharge 1:

$$\phi = \begin{pmatrix} \phi^{++} \\ \phi^+ \\ \phi^0 \end{pmatrix}$$

The peculiar expectation value needed may be generated by a self-interaction of the form

$$H' = -m_1^2 (\underline{\phi} \cdot \underline{\phi}^\dagger) + |\lambda_1| (\underline{\phi} \cdot \underline{\phi}^\dagger)^2 + |\lambda_2| (\underline{\phi}^\dagger \cdot \underline{\phi}^\dagger) (\underline{\phi} \cdot \underline{\phi})$$

A gauge transformation removes the ϕ^\pm and the phase of ϕ^0 leaving a hermitian ϕ^0 and doubly charged $\phi^{\pm\pm}$ as physical scalar bosons of the theory. The masses of the new particles are not determined although $m_W > 53$ GeV. Again there is a mixing angle associated with Z and A. The ϕ^0 coupling to e is again em_e/m_W ; to E it is em_E/m_W . The doubly charged ϕ couples left-handed e^- to right-handed E^+ via an interaction $(em_E/2m_W) \bar{E}^+ (1-\gamma_5) e^- \phi^{++} + \text{h.c.}$ The virtue of the model is that Z decouples completely from the neutrino, allowing the theory to more easily survive experimental challenge.

III. The 2-2 Model

Again the gauge group is U(2) containing W^\pm , A, Z. The e_L^- and e_R^- are each found in doublets

$$\psi_L = \begin{pmatrix} \nu_e \\ e^- \end{pmatrix}_L, \quad \psi_R = \begin{pmatrix} E^0 \\ e^- \end{pmatrix}_R$$

along with a left-handed singlet $\tilde{\psi}_L = E_L^0$. The Higgs fields are again a complex doublet $\phi = (\phi^0, \phi^-)$ as in the Weinberg model, with only the hermitian ϕ^0 remaining physical after the gauge transformation.

The electron mass is put in by hand with a term

$$m_e \bar{\psi}_L \psi_R + \text{h.c.} = m_e (\bar{e}_L e_R + \bar{\nu}_e E_R^0) + \text{h.c.}$$

and the E^0 mass generated by coupling the Higgs field to ψ_R and $\tilde{\psi}_L$ with strength em_E/m_W . The term $m_e \bar{\nu}_e E_R^0$ induces a small amount

of mixing of E_L^0 with ν_e , but the mixing angle α is small; $\alpha \approx m_e/m_{E^0}$. The neutrino remains, of course, massless. This mixing effect, while negligible for electrons, may be of some significance if this model is applied to the muon system, but we ignore it here.

IV. The 3-2 Model

As usual, the U(2) gauge bosons are W^\pm , A, Z and we shall have a Higgs doublet (ϕ^0, ϕ^-) . The e_L^- and ν_e are found in a triplet of zero hypercharge

$$\psi_L = \begin{pmatrix} E^+ \\ \nu_e \cos \alpha + E^0 \sin \alpha \\ e^- \end{pmatrix}_L$$

and e_R^- in a doublet

$$\psi_R = \begin{pmatrix} x^0 \\ e^- \end{pmatrix}_R$$

The right-handed E^+ is best placed in a doublet

$$\psi'_R = \begin{pmatrix} E^+ \\ E^0 \end{pmatrix}_R$$

and the remaining debris are two singlets

$$\psi'_L = (\nu_e \sin \alpha - E^0 \cos \alpha)_L$$

$$\psi''_L = x^0_L.$$

Four terms coupling ϕ to the spinor fields, of the form

$$a \bar{\psi}_L \psi_R \phi^\dagger + b \bar{\psi}_L \psi'_R \phi + c \bar{\psi}'_L \psi'_R \phi + d \bar{\psi}'_L \psi_R \phi^\dagger$$

(where we have suppressed isospin labels and τ matrices), suffice to provide them all with mass; the four parameters also determine the mixing angle α . Put another way, the mixing angle α determines one relation between the fermion masses; it is best written

$$\frac{m_{E^+}}{m_{E^0}} = \sqrt{2} \sin \alpha$$

Despite its rococo character, this model again has the dubious virtue that the neutrino decouples from Z and A, allowing it to better survive the assaults of experimentalists.

V. The 2-3 Model

This is similar to the previous model with

$$\psi_L = \begin{pmatrix} \nu \\ e^- \end{pmatrix}_L$$

a doublet, and

$$\psi_R = \begin{pmatrix} E^+ \\ E^0 \\ e^- \end{pmatrix}_R$$

a triplet, and the usual U(2) quartet W^\pm , A, Z of gauge fields and a Higgs doublet $\phi = (\phi_0, \phi_-)$. However, we now need only one additional doublet of heavy fermions

$$\psi'_L = \begin{pmatrix} E^+ \\ E^0 \end{pmatrix}_L$$

There are two couplings of the Higgs field ϕ to the fermions

$$H' = \frac{em_e}{M_W} \bar{\psi}_L \psi_R \cdot \tau \phi + \frac{em_E}{M_W} \bar{\psi}'_L \psi_R \cdot \tau (\tau_2 \phi^\dagger)$$

As in Model III, a term $(em_e/m_W) \nu_e E_R^0$ induces a small mixing of ν_e with E_L^0 ; again the mixing angle is of order m_e/m_E . Also, evidently m_{E^0} is determined in terms of m_{E^+} ; the ratio is

$$\frac{m_{E^+}}{m_{E^0}} = \sqrt{2}$$

Only one hermitian neutral Higgs field survives; again the coupling strength is em_i/m_W to fermions i .

VI. The Georgi-Glashow (3-3) Model⁴

In this case, the gauge group is SU(2) and the Z is lacking; only W^\pm and photon A are gauge fields. Both e_L^- and e_R^- lie in triplets

$$\underline{\psi}_L = \begin{pmatrix} E^+ \\ \nu_e \sin \alpha + E^0 \cos \alpha \\ e^- \end{pmatrix}_L, \quad \underline{\psi}_R = \begin{pmatrix} E^+ \\ E^0 \\ e^- \end{pmatrix}_R$$

and an additional left-handed singlet

$$\psi'_L = \begin{pmatrix} E^0 \sin \alpha - \nu_e \cos \alpha \end{pmatrix}_L,$$

is mixed in to provide the E^0 mass and keep the ν_e massless. In the Georgi-Glashow version, the Higgs fields form a self-conjugate triplet; however, in that model, the electron mass is the difference of two terms, one of which is bare mass (of order m_{E^+}), the other generated by spontaneous breakdown, proportional to $\langle \phi \rangle$. No rationale is available for the observed smallness of m_e , rendering that version,

in our opinion, utterly unbelievable. Fortunately, it is easy to rephrase the theory in a way such that its credibility becomes, if only highly implausible, at least nonvanishing. This is accomplished by including a neutral Higgs singlet, and using the U(2) notation of 2×2 matrices. Thus

$$\psi_L = \begin{pmatrix} \frac{\nu_e \sin \alpha + E^0 \cos \alpha}{\sqrt{2}}, & E^+ \\ e^-, & \frac{-(\nu_e \sin \alpha + E^0 \cos \alpha)}{\sqrt{2}} \end{pmatrix}_L, \quad \psi_R = \begin{pmatrix} \frac{E^0}{\sqrt{2}}, & E^+ \\ e^-, & -\frac{E^0}{\sqrt{2}} \end{pmatrix}$$

$$\phi = \begin{pmatrix} \phi_1 & \phi^+ \\ \phi^- & -\phi_2 \end{pmatrix}, \quad \langle \phi \rangle = \frac{e}{M_W} \begin{pmatrix} 10 \\ 00 \end{pmatrix}$$

The expectation value $\langle \phi \rangle$ is generated from a Hamiltonian density

$$\mathcal{H}' = -m^2 \text{Tr } \phi^2 + |\lambda| (\text{Tr } \phi^2)^2 - |\lambda'| \text{Tr } \phi^4$$

with $|\lambda'| < |\lambda|$. The mass term is then obtained by coupling ϕ to ψ_L , ψ'_L and ψ_R in all possible ways.

$$\mathcal{L}_M = \frac{em_e}{M_W} \text{Tr } \bar{\psi}_L \psi_R \phi + \frac{eM_{E^+}}{M_W} \left[\text{Tr } \bar{\psi}_L \phi \psi_R + \frac{\tan \alpha}{\sqrt{2}} \bar{\psi}'_L \text{Tr } \psi_R \phi \right]$$

After gauge transformation, two neutral Higgs fields

$$\phi = \begin{pmatrix} \phi_1 & 0 \\ 0 & \phi_2 \end{pmatrix}$$

remain. The masses of ϕ_1 and ϕ_2 are not fixed, but ϕ_1 and ϕ_2 are unmixed (in lowest order). ϕ_1 couples, as usual, to fermion i with coupling-constant em_i/m_W . However, the coupling of ϕ_2 to electron

is large, and the transition coupling $E^0 \rightarrow \nu_e + \phi_2$ is likewise large;

$$H' \sim \frac{e M_{E^+}}{M_W} (\bar{e}_L e_R + \bar{\nu}_e E_R^0 \sin \alpha) \phi_2 + \text{h.c.} + \dots$$

Were the ϕ_2 lighter than E_0 , this would imply a fast decay mode of E^0 into $\phi_2 + \nu_2$; the ϕ_2 in turn would decay very rapidly into $e^+ e^-$, $\mu^+ \mu^-$, or hadrons. Similar conclusions evidently also hold for the M^0 . Also, as pointed out by Primack and Quinn,¹¹ resonant production $e^+ e^- \rightarrow \phi_2 \rightarrow \mu^+ \mu^-$ is readily observable in $e^+ e^-$ colliding beam experiments for this model.

Final Comments

In the even theories (2, 4, 6), the neutrino decouples from the gauge fields; this provides them with special protection against experimental disproof. In the odd theories, the experimental limits on neutral currents may already provide unacceptable constraints. These considerations lie outside the scope of this paper.

Theories 1, 3, 4, 5 all have W^\pm , Z , A , ϕ^- , ϕ^0 coupled in the same way, provided the mixing angle α in theory 4 is chosen to be $\pi/4$. Furthermore, the coupling of e^- and ν_e (the "known" particles) to W^\pm is universal. Thus they are interchangeable, any of the four theories may be used for e^- , any for μ^- , and any generalized to the hadrons. Hence we have really catalogued not 6, but $66 = 4^3 + 2$ possible renormalizable models of weak and electromagnetic interactions. We believe this fact does not significantly change the probability that one of these models is directly applicable to the real world.

In all of the theories, there is a Higgs scalar meson with feeble leptonic couplings identical to those in the Weinberg model. The exceptions are in model 2, containing a doubly charged meson ϕ^{++} , which, if lighter than the E^+ ,

has a very long lifetime, decaying in second order weak interaction to $e^+e^+\nu_e\nu_e$, $\mu^+\mu^+\nu_\mu\nu_\mu$, $\pi^+\pi^+$, etc. If ϕ^{++} is heavier than E^+ , it decays rapidly into E^+e^+ , etc. The other exceptional Higgs meson is the ϕ_2 , which occurs in the Georgi-Glashow model; its coupling to $e(\mu)$ is proportional to the heavy-lepton mass $m_E(m_M)$, a feature which allows its observation in e^+e^- storage rings, provided its mass is sufficiently low.

Appendix B

In this appendix we outline how the preceding models may be generalized to hadrons. There are two features which must be faced in this generalization which invite detailed discussion. The first is how to avoid $\Delta S = 1$ neutral currents, and the second is how to properly generate the bare masses of the hadronic constituents, as well as their Cabibbo mixing. Throughout this section we shall neglect the effect of the strong interaction, arguing that the effective Lagrangian for these processes is governed by the operator product expansion of currents at short distances, which seems experimentally to be unaffected by the presence of strong interactions.

Troublesome diagrams (Figure 13) generating $\Delta S = 1$ neutral currents occur not only in lowest order but in second order. It is not sufficient to have the second order diagrams finite; they must be small enough to contribute negligibly to $\delta m(K_L \leftrightarrow K_S)$ and $K_L \rightarrow \mu^+ \mu^-$.

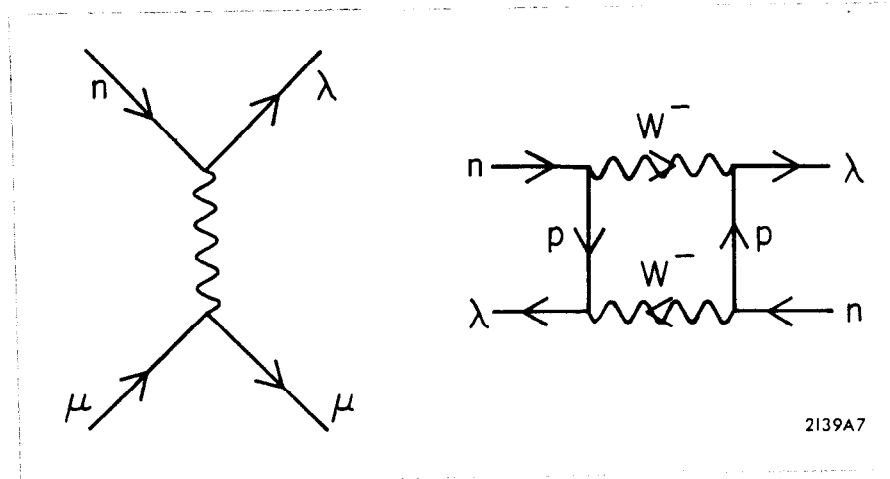

Figure 13

Troublesome $\Delta S = 1$ diagrams

A general way to evade these difficulties,³⁴ and one we shall follow, is to introduce four basic quarks*

$$n' = n \cos \theta + \lambda \sin \theta$$

$$\lambda' = \lambda \cos \theta - n \sin \theta$$

*One may, of course, choose to mix p and q as well as, or instead of, n and λ .

such that there is permutation symmetry of the interaction under the interchange

$$\begin{array}{c} p \longleftrightarrow q \\ n' \longleftrightarrow \lambda' \end{array}$$

except for the mass terms. Then in the absence of fermion mass all neutral-current effects occur in the combination

$$n'^{\dagger} n' + \lambda'^{\dagger} \lambda' = n^{\dagger} n + \lambda^{\dagger} \lambda$$

which has no $\Delta S = 1$ component. By demanding the fermion masses be \lesssim a few GeV, one can hope enough to suppress the effects illustrated in Figure 13 not to be in trouble with experiment.

$\Delta S = 0$ neutral-current effects must then be examined with care; here the experimental situation at present is rapidly changing and we shall not reject any theory on the basis of its disagreement with present data on $\Delta S = 0$ neutral currents.

The second issue to be faced is how to generate the proper mass terms and the Cabibbo mixing. Here we consider the models in turn:

I. Weinberg's model (the 2 - 1 model)

This has been discussed in detail in the literature.^{2,7} The doublets are

$$\psi_L^1 = \begin{pmatrix} p \\ n' \end{pmatrix}_L, \quad \psi_L^2 = \begin{pmatrix} q \\ \lambda' \end{pmatrix}_L$$

with p and q neutral, n' and λ' negative and with singlets $p_R, n'_R, \lambda'_R, q_R$. The eight couplings of the four singlets with either of the ψ^i and with ϕ (or ϕ^+ , depending on what is needed to conserve charge and weak isospin) suffice to generate the four masses and the Cabibbo mixing of n and λ .

II. The Lee-Prentki-Zumino model^{5,6} (the 3 - 1 model)

We may take, for example,

$$\underline{\psi}_L^1 = \begin{pmatrix} P^+ \\ p \\ n' \end{pmatrix}_L, \quad \underline{\psi}_L^2 = \begin{pmatrix} Q^+ \\ q \\ \lambda' \end{pmatrix}_L$$

with $P_R, p_R, n_R, \lambda_R, q_R, Q_R$ all singlets. The most general invariant coupling to $\underline{\phi}$ is $\underline{\phi} \cdot \underline{\psi}_L$, or $\underline{\phi}^+ \cdot \underline{\psi}_L$ which upon replacement of $\underline{\phi}$ by $\langle \phi \rangle$ projects out P_L^+, n_L^+, Q_L^+ , and λ_L' . These can be multiplied by the appropriate right-handed fields to give $P, Q, n,$ and λ masses and to mix n and λ properly. To produce mass for p and q , however, requires additional Higgs particles. To do this most economically, one adds a hermitian triplet of fields (ψ^+, ψ^0, ψ^-) with $\langle \psi^0 \rangle \neq 0$ and obvious couplings to the fermions. This changes the W -boson masses and mixings, but leaves the consequences for the W -fermion couplings essentially unchanged.

III. The 2-2 model

Here we have doublets

$$\psi_L^1 = \begin{pmatrix} p \\ n' \end{pmatrix}_L, \quad \psi_L^2 = \begin{pmatrix} q \\ \lambda' \end{pmatrix}_L$$

with, as usual, p and q neutral and n and λ negatively charged. We also have right-handed doublets

$$\psi_R^1 = \begin{pmatrix} P \\ n' \end{pmatrix}_R, \quad \psi_R^2 = \begin{pmatrix} Q \\ \lambda' \end{pmatrix}_R$$

and singlets P_L, Q_L, p_R, q_R . The couplings $\langle \phi^+ \rangle \psi$ or $\epsilon^{ij} \langle \phi_i \rangle \psi_j$ project out $p_L, q_L, P_R,$ and Q_R and thus such couplings when combined with the appropriate singlet fermion field suffice to give p, q, P, Q mass. Bare mass for n' and λ' may be obtained by an invariant mass term

$$\bar{\psi}_L^i M_{ij} \psi_R^j$$

present even in the absence of Higgs fields.

IV. The 3 - 2 model

Here we may take

$$\underline{\psi}_L^1 = \begin{pmatrix} P^+ \\ p \\ n' \end{pmatrix}_L \quad \underline{\psi}_L^2 = \begin{pmatrix} Q^+ \\ q \\ \lambda' \end{pmatrix}_L$$

with doublets

$$\psi_R^1 = \begin{pmatrix} P^0 \\ n' \end{pmatrix}_R \quad \psi_R^2 = \begin{pmatrix} Q^0 \\ \lambda' \end{pmatrix}_R \quad \psi_R^3 = \begin{pmatrix} P^+ \\ R^0 \end{pmatrix}_R \quad \psi_R^4 = \begin{pmatrix} Q^+ \\ S^0 \end{pmatrix}_R$$

and singlets P_L^0 , Q_L^0 , p_R , q_R , R_L^0 , S_L^0 .

By contracting ψ_R^i with ϕ or ϕ^+ , we again project out any of the doublet fermion fields, and thereby generate mass for P^0 , Q^0 , R^0 , and S^0 . From couplings

$$\begin{aligned} \bar{\psi}_R^i (\underline{1} \cdot \underline{\psi}_L^j) \langle \phi \rangle & \quad i = 1, 2 \\ \psi_R^i (\underline{1} \cdot \underline{\psi}_L^j) \langle \tau_2 \phi^+ \rangle & \quad i = 3, 4 \end{aligned}$$

the P^+ , Q^+ , n , and λ masses may be generated as well as the Cabibbo mixing.

V. The 2 - 3 model

In this case we write

$$\psi_L^1 = \begin{pmatrix} P \\ n' \end{pmatrix}_L \quad \psi_L^2 = \begin{pmatrix} q \\ \lambda' \end{pmatrix}_L$$

supplemented with

$$\psi_L^3 = \begin{pmatrix} P^+ \\ P^0 \end{pmatrix}_L \quad \psi_L^4 = \begin{pmatrix} Q^+ \\ Q^0 \end{pmatrix}_L$$

with right-handed triplets

$$\underline{\psi}_R^1 = \begin{pmatrix} P^+ \\ P^0 \\ n' \end{pmatrix}_R \quad \underline{\psi}_R^2 = \begin{pmatrix} Q^+ \\ Q^0 \\ \lambda' \end{pmatrix}_R$$

and singlets p_R, q_R . The coupling of fermion doublets to Higgs doublets $\langle \phi \rangle \langle \phi^+ \rangle$ suffices to give p and q mass. Again terms

$$\bar{\psi}_L^i (\underline{\tau} \cdot \underline{\psi}_R^j) \langle \phi \rangle \quad i = 1, 2$$

$$\bar{\psi}_L^i (\underline{\tau} \cdot \underline{\psi}_R^j) \langle \tau_2 \phi \rangle \quad i = 3, 4$$

give $n, \lambda, P^+, Q^+, p^0, Q^0$ mass as well as providing the Cabibbo mixing.

VI. The Georgi-Glashow (3-3) Model

The version presented here differs in detail from that of Georgi and Glashow,⁴ both because of the Higgs quartet and because of the assumed "SU(4)" mechanism used to suppress $\Delta S=1$ neutral currents. Thus we end up with eight basic constituents instead of five. Start with

$$\psi_L^1 = \begin{pmatrix} \frac{p \sin \alpha + P^0 \cos \alpha}{\sqrt{2}}, P^+ \\ n', -\frac{p \sin \alpha + P^0 \cos \alpha}{\sqrt{2}} \end{pmatrix}, \quad \psi_R^1 = \begin{pmatrix} \frac{P^0}{\sqrt{2}}, P^+ \\ n', -\frac{P^0}{\sqrt{2}} \end{pmatrix}$$

$$\psi_L^2 = \begin{pmatrix} \frac{q \sin \alpha + Q^0 \cos \alpha}{\sqrt{2}}, Q^+ \\ \lambda', -\frac{q \sin \alpha + Q^0 \cos \alpha}{\sqrt{2}} \end{pmatrix}, \quad \psi_R^2 = \begin{pmatrix} \frac{Q^0}{\sqrt{2}}, Q^+ \\ \lambda', -\frac{Q^0}{\sqrt{2}} \end{pmatrix}$$

Add singlets p_R, q_R , and

$$(p \cos \alpha - P^0 \sin \alpha)_L = \chi_L^1$$

$$(q \cos \alpha - Q^0 \sin \alpha)_L = \chi_L^2$$

With, as before, $\langle \phi \rangle = \begin{pmatrix} \langle \phi \rangle & 0 \\ 0 & 0 \end{pmatrix}$ we generate P^+ , P^0 mass from terms

$$\text{Tr } \bar{\psi}_L^i \phi \psi_R^i + \frac{\tan \alpha}{\sqrt{2}} \bar{\chi}_L^i \text{Tr } \psi_R^i \phi$$

n and λ mass comes from $\text{Tr } \bar{\psi}_R^i \langle \phi \rangle \psi^i$ and from $\text{tr} \left[\psi_L^1, \psi_R^2 \right] \langle \phi \rangle$. The mass of p and q is generated from terms such as

$$\bar{p}_R \chi_L^1 \text{Tr } \langle \phi \rangle + \text{h. c.}$$

$$\bar{q}_R \chi_L^2 \text{Tr } \langle \phi \rangle + \text{h. c.}$$

Concluding comments

1. We conclude that it is not difficult to generate appropriate mass-terms and Cabibbo mixings, but that at least in the cases considered the procedure is ad hoc and yields nothing out that was not put in. We record the couplings of the usual currents to the vector mesons in these models, as well as the number of new "charmed" hadron constituents in the various models in Table 1.

2. In these schemes, "charmed" constituents play a role; from the cut-off estimates³⁶ for $\delta m (K_L - K_S)$ and from $K_L \rightarrow \mu^+ \mu^-$, we expect the bare mass of such constituents not to exceed $\sim 5 - 15$ GeV. Given approximate universality between lepton and hadron properties, including symmetry breaking [e.g., $m_\mu \approx (m_\lambda - m_p)$], we might expect this to be a rough upper bound to the heavy-lepton masses in such theories. While we write these words as encouragement to the experimentalist, we emphasize that failure to find heavy leptons of mass $\lesssim 10$ GeV is not a death-blow to models of this class.

3. We have ignored problems associated with the Adler-Bell-Jackiw anomaly.³⁷ We believe that even if a model is non-renormalizable because of anomalies, the effect occurs only in high orders of perturbation theory. Indeed

the first trouble appears to come in the diagrams of Figure 14. This would

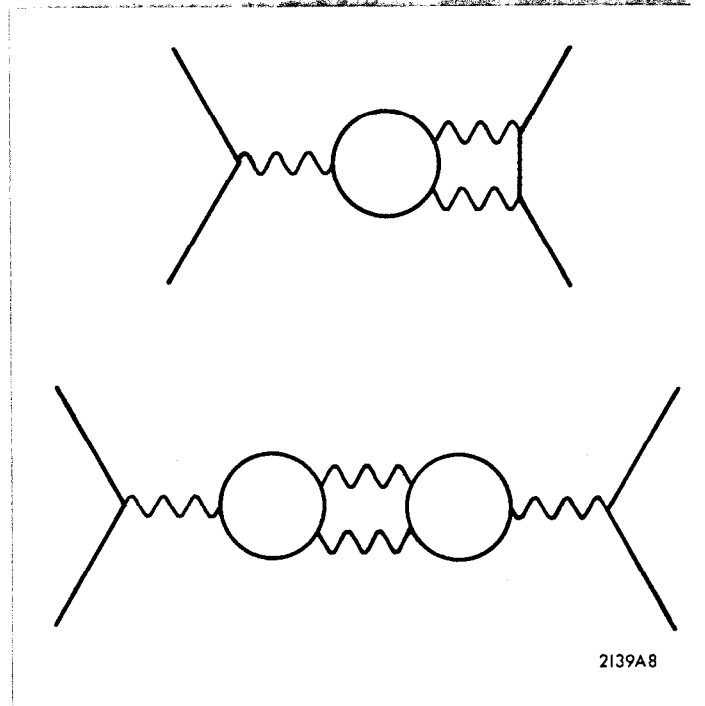

Figure 14

The simplest unrenormalizable diagram in theories with anomalies.

indicate a nonrenormalizable perturbation expansion

$$T \sim g^2 T_2 + g^4 T_4 + g^6 T_6 \log \lambda^2 + g^8 T_8 \frac{\lambda^2}{M^2} + \dots$$

$$\sim g^2 T_2 + g^4 T_4 + g^6 \log g^2 T_6 + g^6 f \left(\frac{g^2 \lambda^2}{m^2} \right) + \dots$$

where we suppose the Lee-Yang ξ -limiting summation procedure applies. Thus only the g^6 term and higher terms become uncalculable. This is no reason to reject a theory. From the physics point of view, the major criterion for acceptability of a theory is only that the lowest order amplitude T_2 not be renormalized by a large amount; this would disrupt the regularities (universality of strength; charged currents dominant) which appear in the low energy data.

Table I

Theory	I	II	III	IV	V	VI
J=1 bosons	W^\pm, Z, A	W^\pm, Z, A	W^\pm, Z, A	W^\pm, Z, A	W^\pm, Z, A	W^\pm, A
J=0 bosons	ϕ^0	$\phi^{\pm\pm}, \phi^0$ ψ^\pm, ψ^0	ϕ^0	ϕ^0	ϕ^0	ϕ_1^0, ϕ_2^0
Leptons	ν_e, e^-	E^+, ν_e, e^-	E^0, ν_e, e^-	E^+, E^0, ν_e, e^-	E^+, E^0, ν_e, e^-	E^+, E^0, ν_e, e^-
Hadron constituents	q^0, p^0, n^-, λ^-	Q^+, P^0 q^0, p^0, n^-, λ^-	P^0, Q^0 q^0, p^0, n^-, λ^-	P^+, Q^+, P^0, Q^0 R^0, S^0 q^0, p^0, n^-, λ^-	P^+, Q^+, P^0, Q^0 q^0, p^0, n^-, λ^-	P^+, Q^+, P^0, Q^0 q^0, p^0, n^-, λ^-
Couplings:						
$\frac{g_L}{e} (\nu_e^\dagger e^- W^+)$	$2^{-\frac{1}{2}} \csc \theta$	$\csc \theta$	$2^{-\frac{1}{2}} \csc \theta$	$\cos \alpha \csc \theta$	$2^{-\frac{1}{2}} \csc \theta$	$\sin \alpha$
$\frac{g_L}{e} (E^{\dagger} \nu_e W^+)$	-	$-\csc \theta$	-	$\cos \alpha \csc \theta$	0	$-\sin \alpha$
$\frac{g_L}{e} (E^{\dagger} e^- W^+)$	-	-	0	$\sin \alpha \csc \theta$	≈ 0	$\cos \alpha$
$\frac{g_R}{e} (E^{\dagger} e^- W^+)$	-	-	$2^{-\frac{1}{2}} \csc \theta$	0	$-\csc \theta$	+1
$\frac{g_L}{e} (E^{\dagger} E^0 W^+)$	-	-	-	$\sin \alpha \csc \theta$	$2^{-\frac{1}{2}} \csc \theta$	$-\cos \alpha$
$\frac{g_R}{e} (E^{\dagger} E^0 W^+)$	-	-	-	$-2^{-\frac{1}{2}} \csc \theta$	$-\csc \theta$	-1

	I	II	III	IV	V	VI
$\frac{g_L}{e} (e^{-\dagger} e^{-} Z)$	$-\cot 2\theta$	$-\cot \theta$	$-\cot 2\theta$	$-\cot \theta$	$-\cot 2\theta$	-
$\frac{g_R}{e} (e^{-\dagger} e^{-} Z)$	$\tan \theta$	$\tan \theta$	$-\cot 2\theta$	$-\cot 2\theta$	$-\cot \theta$	-
$\frac{g_L}{e} (\nu_e^{\dagger} \nu_e Z)$	$\csc 2\theta$	0	$\csc 2\theta$	0	$\csc 2\theta$	
$\frac{g_L}{e} (E^{0\dagger} E^0 Z)$	-	-	0	0	$-\csc 2\theta$	-
$\frac{g_R}{e} (E^{0\dagger} E^0 Z)$	-	-	$\csc 2\theta$	$-\csc 2\theta$	0	-
$\frac{g_L}{e} (E^{+\dagger} E^+ Z)$	-	$+\cot \theta$	-	$\cot \theta$	$\cot 2\theta$	-
$\frac{g_R}{e} (E^{+\dagger} E^+ Z)$	-	$-\tan \theta$	-	$\cot 2\theta$	$\cot \theta$	-
$\frac{g_L}{e} (x^{0\dagger} x^0 Z)$	-	-	-	0	-	-
$\frac{g_R}{e} (x^{0\dagger} x^0 Z)$	-	-	-	$\csc 2\theta$	-	-
$\frac{g_L}{e} (x^{0\dagger} e^{-} W^+)$	-	-	-	0	-	-
$\frac{g_R}{e} (x^{0\dagger} e^{-} W^+)$	-	-	-	$2^{-\frac{1}{2}} \csc \theta$	-	-

	I	II	III	IV	V	VI
m_W (GeV)	$37 \csc \theta $	$53 \csc \theta $	$37 \csc \theta $	$53 \cos \alpha \csc \theta $	$37 \csc \theta $	$53 \sin \alpha $
m_Z/m_W	$ \sec \theta $	$\sqrt{2} \sec \theta $	$ \sec \theta $	$ \sec \theta $	$ \sec \theta $	-
m_{E^+}/m_{E^0}	-	-	-	$\sqrt{2} \sin \alpha $	$\sqrt{2}$	$\frac{1}{2} \sec \alpha $
$\frac{g_L}{e} (p^\dagger n' W^+)$ [$g_R = 0$]	$2^{-\frac{1}{2}} \csc \theta$	$\csc \theta$	$2^{-\frac{1}{2}} \csc \theta$	$\cos \alpha \csc \theta$	$2^{-\frac{1}{2}} \csc \theta$	$\sin \alpha$
$\frac{g_L}{e} (p^\dagger p Z^0)$	$-\csc 2\theta$	0	$\csc 2\theta$	0	$\csc 2\theta$	-
$\frac{g_R}{e} (p^\dagger p Z^0)$	0	0	$\csc 2\theta$	$-\csc 2\theta$	0	-
$\frac{g_L}{e} \begin{pmatrix} n^\dagger n Z_i^0 \\ \lambda^\dagger \lambda Z^0 \end{pmatrix}$	$\cot 2\theta$	$-\cot \theta$	$-\cot 2\theta$	$-\cot \theta$	$-\cot 2\theta$	-
$\frac{g_R}{e} \begin{pmatrix} n^\dagger n Z_i^0 \\ \lambda^\dagger \lambda Z^0 \end{pmatrix}$	$-\tan \theta$	$-\tan \theta$	$-\cot 2\theta$	$-\cot 2\theta$	$-\cot \theta$	-

References

1. A. Salam and J. C. Ward, Phys. Letters 13, 168 (1964). A. Salam in Elementary Particle Theory, ed. N. Svartholm (Almqvist and Forlag A. B. Stockholm, 1968).
2. S. Weinberg, Phys. Rev. Letters 19, 1264 (1967) and 27, 1688 (1971); Phys. Rev. D5, 1412 (1972) and D5, 1962 (1972).
3. G. 't Hooft, Nucl. Physics B35, 167 (1971).
4. H. Georgi and S. L. Glashow, Phys. Rev. Letters 28, 1494 (1972).
5. B. W. Lee, NAL preprint, THY-51 (1972). (Submitted to Comments and Addenda section of Phys. Rev. D).
6. J. Prentki and B. Zumino, CERN preprint TH 1504 (1972). (Submitted to Nuclear Physics B).
7. For references to some of the other papers on this subject which had appeared in early 1972, see: B. W. Lee, NAL preprint THY-34 (1972). (Invited paper presented at the San Francisco meeting of the APS, January 1972).

C. H. Llewellyn Smith, SLAC preprint, SLAC-PUB-1039. (Invited paper presented at the Fourth International Conference on High Energy Collisions, Oxford, England, April 1972; to be published).
8. H. H. Chen and B. W. Lee, Phys. Rev. D5, 1874 (1972). C. H. Albright, Phys. Rev. D2, 1330 (1970).
9. Wonyong Lee, "Experimental Limit on the Neutral Current in the Semi-leptonic Processes," Columbia preprint (1972).
10. M. Gell-Mann, M. Goldberger, N. Kroll, and F. E. Low, Phys. Rev. 179, 1518 (1969).

11. J. Primack and H. Quinn, "Muon $g-2$ and Other Constraints on a Model of Weak and Electromagnetic Interactions Without Neutral Currents," Harvard preprint (revised version) (1972) (to be published in Phys. Rev.).
12. The branching ratios of heavy leptons have been considered previously by many authors (see, e. g., references 13 - 19) but always with more restricted parameters. Whenever possible, we make comparison with the work of Tsai (reference 19) whose treatment seems to be the most complete.
13. E. M. Lipmanov, JETP 19, 1291 (1964). (Russian original: 46, 1917 (1964)).
14. K. W. Rothe and A. M. Wolsky, Nucl. Physics B10, 241 (1969).
15. A. K. Mann, Nuovo Cimento Letters 1, 486 (1971).
16. J. J. Sakurai, Nuovo Cimento Letters 1, 624 (1971).
17. E. W. Beier, Nuovo Cimento Letters 1, 1118 (1971).
18. H. B. Thacker and J. J. Sakurai, Physics Letters 36B, 103 (1971).
19. Y. S. Tsai, Phys. Rev. D4, 2821 (1971).
20. T. Das, V. S. Mathur and S. Okubo, Phys. Rev. Letters 18, 761 (1967).
21. T. Das, V. S. Mathur and S. Okubo, Phys. Rev. Letters 19, 470 (1967).
22. C. Bacci et al., Physics Letters 38B, 551 (1972). See also D. M. Ritson, invited paper presented at the Philadelphia Meson Conference, April 1972 (SLAC-PUB-1043), in which data from several Frascati groups are combined.
23. J. LeFrancois, p. 51 in "Proceedings of the 1971 International Symposium on Electron and Photon Interactions at High Energy," (Laboratory for Nuclear Studies at Cornell, 1972).
24. S. Weinberg, Phys. Rev. Letters 18, 507 (1967).
25. K. J. Kim and Y. S. Tsai, SLAC preprint, SLAC-PUB-1030 (1972).
26. The conclusion that earlier CERN data implied that heavy leptons coupled to ν_{μ} must be heavier than 1 GeV was reached by S. S. Gerstein and V. N. Folomeshkin, Soviet Journal of Nuclear Physics 8, 447 (1969). (Russian original: Yadernaya Fisika 8, 768 (1968)).

27. S. D. Drell and T. M. Yan, Phys. Rev. Letters 25, 316 (1970).
28. S. M. Berman (private communication).
29. Various possibilities have been discussed in references 13 - 19 and by
 E. M. Lipmanov, JETP 16, 634 (1963) (Russian original: 43, 893 (1962)).
 Ya. B. Zeldovitch Uspekhi 5, 931 (1963) (Russian original: 78, 549 (1962)).
 F. E. Low, Phys. Rev. Letters 14, 238 (1965). S. S. Gerstein, L. S.
 Landsberg and V. N. Folomeshkin, IHEP preprint IHEP 71-54.
30. M. Perl, SLAC preprint, SLAC-PUB-1062 (1972).
31. T. D. Lee and C. N. Yang, Phys. Rev. 119, 1410 (1961). A. Pais, Phys.
 Rev. Letters 9, 117 (1962). A. Pais and S. B. Treiman, p. 257 in
 Anniversary Volume dedicated to N. N. Bololibov, Nauka, Moscow (1969).
32. C. H. Albright, Phys. Rev. Letters 28, 1150 (1972).
33. P. W. Higgs, Phys. Letters 12, 132 (1964); Phys. Rev. Letters 13, 508
 (1964); and Phys. Rev. 145, 1156 (1966).
34. S. Glashow, J. Iliopoulos and L. Maiani, Phys. Rev. D2, 1285 (1970).
35. B. W. Lee, Phys. Rev. D5, 823 (1972). B. W. Lee and J. Zinn-Justin,
 Phys. Rev. D5, 3121, 3137, and 3155 (1972).
 G. 't Hooft and M. Veltman, Nucl. Phys. B44, 189 (1972).
36. B. L. Ioffe and E. P. Shabalin, Soviet Journal of Nucl. Phys. 6, 328 (1967),
 (Russian original: Yadernaya Fisika 6, 828, 1967)).
37. In the context of gauge theories anomalies have been considered by:
 C. Bouchiat, J. Iliopoulos and Ph. Meyer, Phys. Letters 38B, 519 (1972);
 D. J. Gross and R. Jackiw, MIT Preprint 262 (1972).

FIGURE CAPTIONS

1. Diagrams for the process $e^+e^- \rightarrow W^+W^-$
2. Additional contributions to the process $e^+e^- \rightarrow W^+W^-$
3. Diagrams which may make important contributions to $(g-2)_\mu$
4. Diagrams contributing to the decay $E^0 \rightarrow \gamma\nu$
5. Branching ratios (in percent) for the decays $E^+ \rightarrow \nu_e + \dots$ as a function of M_E with the assumptions discussed in the text.
6. $\Gamma(E^+ \rightarrow \nu_e + \text{anything})$ in sec^{-1} as a function of M_E with the same assumptions as in Figure 5.
7. The function $S(z, t)$ (Eq. 2. 16), which determines in part the relative importance of various hadronic modes in decays $E^{(\uparrow)} \rightarrow E^{(\downarrow)} + \text{hadrons}$, plotted against \sqrt{t}/M_E for various values of z .
8. The functions $f_1(z)$ and $f_2(z)$ (Eq. 2. 3) plotted against z .
9. Diagram contributing to the decay $e^+e^- \rightarrow E^0\nu_e$
10. Diagram which might contribute to the decay $e^+e^- \rightarrow \bar{E}_0\nu_e$
11. $\sigma(e^+e^- \rightarrow \bar{E}_0\nu_e)$ as a function of the beam energy. The left-hand scale was obtained assuming $\left[g_R^2 + \frac{1}{3} g_L^2 \right] = g^2$. The right-hand scale follows from the bound in Eq. (3. 5).
12. The function Φ (Eq. 3. 8), which determines the ratio of M^+ to μ^- production in $\nu_\mu + A$ collisions, as a function of S/M_M^2 assuming $\bar{f} = 0$, $f \sim \nu W_2^{\text{ep}}$. This curve is of course only approximate.
13. Troublesome $\Delta S = 1$ diagrams
14. The simplest unrenormalizable diagram in theories with anomalies.

Figure Captions

- Figure 5: Branching ratios (in percent) for the decays $E^+ \rightarrow \nu_e + \dots$ as a function of M_E with the assumptions discussed in the text.
- Figure 6: $\Gamma(E^+ \rightarrow \nu_e + \text{anything})$ in sec^{-1} as a function of M_E with the same assumptions as in Figure 5.
- Figure 7: The function $S(z, t)$ (Eq. 2.16), which determines in part the relative importance of various hadronic modes in decays $E^{(\dagger)} \rightarrow E^{(\ddagger)} + \text{hadrons}$, plotted against \sqrt{t}/M_E for various values of z .
- Figure 8: The functions $f_1(z)$ and $f_2(z)$ (Eq. 2.3) plotted against z .
- Figure 11: $\sigma(e^+e^- \rightarrow \bar{E}^0 \nu_e)$ as a function of the beam energy. The left-hand scale was obtained assuming $\left[g_R^2 + \frac{1}{3} g_L^2 \right] = g^2$. The right-hand scale follows from the bound in Eq. (3.5).
- Figure 12: The function Φ (Eq. 3.8), which determines the ratio of M^+ to μ^- production in $\nu_\mu + A$ collisions, as a function of S/M_M^2 assuming $\bar{f} = 0$, $f \sim \nu W_2^{\text{ep}}$. This curve is of course only approximate.