

THE STABILITY OF THE SCHWARZSCHILD METRIC *

by

C. V. Vishveshwara
"

Dissertation submitted to the Faculty of the Graduate School
of the University of Maryland in partial fulfillment
of the requirements for the degree of
Doctor of Philosophy
1968

Co p. 1

* Supported in part by NASA Contract NsG-436

APPROVAL SHEET

Title of Thesis: The Stability of the Schwarzschild Metric

Name of Candidate: C. V. Vishveshwara
Doctor of Philosophy, 1968

Thesis and Abstract Approved:

Charles W. Misner

Charles W. Misner
Professor of Physics
Department of Physics and Astronomy

Date Approved: *March 11, 1968*

ABSTRACT

C. V. Vishveshwara
Ph.D., gen
U of Maryland

Title of Thesis: The Stability of the Schwarzschild Metric

C. V. Vishveshwara, Doctor of Philosophy, 1968

~~Thesis Directed by:~~ Professor of Physics, Charles W. Misner

Sup.

The stability of the Schwarzschild exterior metric against small perturbations is investigated. The exterior extending from the Schwarzschild radius $r = 2m$ to spatial infinity is visualized as having been produced by a spherically symmetric mass distribution that collapsed into the Schwarzschild horizon in the remote past. As a preamble to the stability analysis, the phenomenon of spherically symmetric gravitational collapse is discussed under the conditions of zero pressure, absence of rotation and adiabatic flow. This is followed by a brief study of the Kruskal coordinates in which the apparent singularity at $r = 2m$ is no longer present; the process of spherical collapse and the consequent production of the Schwarzschild empty space geometry down to the Schwarzschild horizon are depicted on the Kruskal diagram.

The perturbations superposed on the Schwarzschild background metric are the same as those given by Regge and Wheeler consisting of odd and even parity classes, and with the time dependence $\exp(-ikt)$, where k is the frequency. An analysis of the Einstein field equations computed to first order in the perturbations away from the Schwarzschild background metric shows that when the frequency is made purely imaginary, the solutions that vanish at large values of r , conforming to the requirement of asymptotic flatness, will diverge near the Schwarzschild surface in the Kruskal coordinates even at the initial instant $t = 0$. Since the background metric itself is finite at this surface, the above behaviour of the perturbation clearly contradicts the basic assumption that the perturbations are small compared to the background metric. Thus perturbations with imaginary

1000
A. V. Vishveshwara

frequencies that grow exponentially with time are physically unacceptable and hence the metric is stable. In the case of the odd perturbations, the above proof of stability is made rigorous by showing that the radial functions for real values of k form a complete set, by superposition of which any well behaved initial perturbation can be represented so that the time development of such a perturbation is non-divergent, since each of the component modes is purely oscillatory in time. A similar rigorous extension of the proof of stability has not been possible in the case of the even perturbations because the frequency (or k^2) does not appear linearly in the differential equation.

A study of stationary perturbations ($k = 0$) shows that the only nontrivial stationary perturbation that can exist is that due to the rotation of the source which is given by the odd perturbation with the angular momentum $\ell = 1$. Finally, complex frequencies are introduced under the boundary conditions of only outgoing waves at infinity and purely incoming waves at the Schwarzschild surface. The physical significance of this situation is discussed and its connection with phenomena such as radiation damping and resonance scattering, and with the idea of causality is pointed out.

Handwritten note: $\ell = 1$ odd perturbation

ACKNOWLEDGEMENTS

I wish to express my deepest gratitude to my advisor Professor Charles Misner for close support and constant guidance he has given me during the course of the present work. I am indebted to Professor Joseph Weber for the encouragement I have received from him. I would like to thank Dr. H. Zapolsky, Dr. A. J. Dragt and Dr. G. V. Ramanathan for many helpful discussions. I gratefully acknowledge the financial support obtained from a grant held by Professor Joseph Weber from the National Aeronautics and Space Administration.

My warmest thanks are due to Mrs. J. Alexander and Mrs. B. Alexander for typing the thesis with patience and care. Finally it is a pleasure to thank Mr. Alan McCone most sincerely for reading the proofs as well as the manuscript.

TABLE OF CONTENTS

| Chapter | Page |
|--|------|
| ACKNOWLEDGEMENTS..... | ii |
| I. INTRODUCTION AND SUMMARY..... | 1 |
| II. THE PROBLEM OF STABILITY: GENERAL CONSIDERATIONS..... | 7 |
| A. An Illustrative Example: The Oscillating Liquid Drop.... | 7 |
| B. Regge-Wheeler Approach to the Stability of the Schwarzschild Metric..... | 13 |
| C. Gravitational Collapse..... | 16 |
| D. Kruskal Coordinates..... | 23 |
| E. Perturbation Analysis in Kruskal Coordinates..... | 26 |
| III. THE STABILITY OF THE SCHWARZSCHILD METRIC - NAIVE VIEWPOINT.. | 28 |
| A. Perturbations in the Schwarzschild Coordinates..... | 28 |
| B. Transformations to the Kruskal Coordinates..... | 30 |
| C. The Odd Parity Perturbations..... | 31 |
| D. The Even Parity Perturbations..... | 38 |
| E. The Perturbations with Real Frequencies..... | 44 |
| IV. OTHER BOUNDARY CONDITIONS..... | 46 |
| A. Stationary Perturbations..... | 46 |
| B. Perturbations with Complex Frequencies..... | 51 |
| V. THE STABILITY OF THE SCHWARZSCHILD METRIC - RIGOROUS TREATMENT..... | 59 |
| A. The Odd Parity Perturbations..... | 61 |
| B. The Even Parity Perturbations..... | 66 |
| FOOTNOTES AND REFERENCES..... | 69b |

APPENDIX A..... 70
APPENDIX B..... 76
APPENDIX C..... 88

LIST OF FIGURES

| Figure | Page |
|----------------------------|------|
| Figure for Appendix B..... | 87 |
| 1..... | 93 |
| 2..... | 94 |
| 3..... | 95 |
| 4..... | 96 |

CHAPTER I

INTRODUCTION AND SUMMARY

In recent years the phenomenon of gravitational collapse as described within the framework of classical general relativity has been a subject of great interest and extensive research¹. A star which contains roughly more than twice the number of baryons in the sun and has reached the end point of its thermonuclear evolution cannot sustain itself against the gravitational forces and therefore is forced to collapse progressively to zero volume, unless the hitherto undiscovered quantum effects halt the process. Oppenheimer and Snyder², in their pioneering work on the subject, studied the free-fall collapse of a spherical star. Owing to the overwhelming computational difficulties involved in a more realistic situation, subsequent investigators have essentially confined themselves to the idealized case of spherical symmetry. The geometry surrounding such a collapsing, non-radiating, spherical object, as is well known from the Birkhoff³, theorem is given by the Schwarzschild exterior metric:

$$ds^2 = - \left(1 - \frac{2m}{r}\right) dt^2 + \left(1 - \frac{2m}{r}\right)^{-1} dr^2 + r^2 (d\theta^2 + \sin^2\theta d\phi^2).$$

As the collapse proceeds, eventually the surface of the collapsing mass enters the Schwarzschild surface $r = 2m$ in a finite proper time; to an external observer, however, the collapsing star appears to slow down as it nears the gravitational radius and to him the asymptotic approach of the stellar surface to the Schwarzschild radius is the final picture of the whole process. In other words, a spherical configuration that has collapsed into the Schwarzschild "horizon" in the remote past is represented by the Schwarzschild exterior geometry extending from $r = 2m$ to infinity. In view of the fact that physical phenomena do exist that give rise to objects described by the Schwarzschild empty space geometry down to $r = 2m$, the geometry itself, as well as the horizon $r = 2m$, remains no longer a subject of mere mathematical interest, but, on the contrary,

judge whether any divergence shown by the perturbation at this surface was real or only a spurious effect caused by improper choice of coordinates. The discovery of the Kruskal coordinates⁵ has since then remedied the situation. In these coordinates the background metric is singularity-free down to the point $r = 0$ and the surface $r = 2m$ no longer displays the apparent pathologies that were originally present. The correct way to solve the problem is to carry out the perturbation analysis entirely in the Kruskal reference frame which, however, would be a difficult task, since in the Kruskal coordinates the metric does not display its time-independence. Equivalently, we solve for the perturbations employing the Schwarzschild coordinates, transform the solutions thus found to the Kruskal coordinates and study their behavior which would now be free from effects due to improper choice of coordinates.

As has been pointed out by several authors (see Appendix A), the differential equations for the radial factors of the perturbations contained errors as they appeared in the literature. In collaboration with L. Edelman, I have obtained the correct set of differential equations for these radial factors and checked their internal consistency. Edelman has been able to derive a second order differential equation for a single radial factor in case of the "even parity" perturbations which was hitherto unavailable. This equation simplifies the stability analysis to a considerable degree. With the help of these corrected equations and by employing the Kruskal coordinates to examine the behavior of the perturbations near the Schwarzschild surface, it has been now possible to solve the problem originally posed by Regge and Wheeler and establish the stability of the Schwarzschild metric.

In Chapter II we first deal with some general considerations pertaining to the stability problems in physics. In order to explain the analysis of

such problems we give an illustrative example from hydrodynamics, namely, the oscillations of a uniformly charged spherical drop of incompressible fluid subject to capillary forces. This problem and that of the stability of the Schwarzschild metric share the common feature of spherical symmetry and consequently bear certain similarities, although in the latter case the analysis proceeds along somewhat different lines on account of the complexities involved. In the second half of that chapter, we briefly outline the Regge-Wheeler approach to the stability of the Schwarzschild metric. This is followed by a discussion of the gravitational collapse of a spherical distribution of mass with no pressure and the consequent production of the Schwarzschild geometry beyond $r = 2m$. The next section of that chapter consists of a brief study of the Kruskal coordinates and the representation on the Kruskal diagram of the geometry produced by a spherical mass that has collapsed into the Schwarzschild horizon in the remote past. Finally the basic principles underlying our proof of the stability of the Schwarzschild space-time, as it will be presented in the third chapter, are stated.

In Chapter III we take up the problem of stability as originally formulated by Regge and Wheeler. The question raised here is the same as raised by those authors: with the time-dependence of the perturbations as $\exp(-ikt)$, where k is the frequency, are purely imaginary frequencies that make the perturbations grow exponentially with time admissible? In order to answer this question we study the solutions of the first order Einstein field equations corresponding to imaginary values of k . The solutions that vanish at spatial infinity at the initial instant diverge in the Kruskal coordinates near the Schwarzschild horizon thereby contradicting the basic assumption that the perturbations are small compared to the background metric. Such perturbations are physically

unacceptable and hence the Schwarzschild metric is stable. In the course of our discussion of stability we also study perturbations with real frequencies (gravitational waves) and their superposition leading to wave packets.

Chapter IV deals with two other types of perturbations. In the first section stationary perturbations with $k = 0$ are examined. These perturbations were studied by Regge and Wheeler also. Our analysis clearly contradicts certain conjectures made by these authors. It will be shown that the only non-trivial stationary perturbation is due to the rotation of the source. This conclusion has been arrived at by Doroshkevich et al⁶, although their analysis was not complete as we shall see later. In the second section we introduce complex frequencies for odd perturbations and impose the boundary conditions of only outgoing waves at infinity and purely incoming waves at $r = 2m$. We shall see that such a situation will lead to phenomena such as radiation damping and resonance scattering. At the same time the concept of causality emerges from the formalism and its validity points towards the stability of the background metric.

In Chapter V we return to the problem of stability. We shall re-examine the proof given in Chapter III and point out its inadequacy and lack of rigor. In Chapter III we show that a perturbation with a given imaginary value of k , obtained as a solution of the field equations, is physically unacceptable. We do not however show that in order to construct any initially well-behaved perturbations these modes are not needed. If such modes are needed to represent the initial perturbation, that perturbation may grow in time showing the instability of the background. In Chapter V we shall show that, in the case of the odd perturbations the radial functions corresponding to only real values of k form a complete set which can be superposed to build the initial perturbation, thereby proving rigorously the stability against the odd perturbations. Owing to the complexity of the field equations such a proof is not possible in case

of the even perturbations. We discuss, nevertheless, features that indicate that the metric is possibly stable against the even perturbations also.

In the main body of the thesis only the immediately relevant field equations for perturbations are cited for the sake of simplicity. The details regarding these field equations are given in Appendix A. In Chapter II, we introduce Killing vectors to derive gravitational red shift formula. In Appendix B we present an extension of the technique to generalize the Schwarzschild surface to arbitrary static and stationary metrics. Appendix C contains mathematical computations pertaining to the discussions at the end of Chapter V.

THE PROBLEM OF STABILITY: GENERAL CONSIDERATIONS

The problem of stability is encountered in various branches of physics - hydrodynamics, hydromagnetics and astrophysics being familiar examples. We have, to start with, a physical system in a stationary state, i.e., a state described by variables none of which is time dependent, governed by relevant equations. Any such system is liable to be acted upon by small disturbances and we wish to study the stability of the system against these disturbances. The question here is whether any perturbation impressed upon the system will oscillate about the original state without growing in amplitude or it will progressively grow with time thereby making the system deviate from its initial state. These two situations correspond respectively to the stable and the unstable states of the system.

In order to illustrate the formalism adopted in solving the problem of stability as above we borrow a classic example from hydrodynamics: the oscillations of a spherical drop of incompressible fluid with a uniform volume distribution of electric charge and subject to surface-tension forces. The problem was first solved by Rayleigh⁷ and later on the result was applied to the liquid drop model of the nucleus⁸.

A. An Illustrative Example: The Oscillating Liquid Drop

Consider a spherical drop of incompressible fluid of radius R , mass M and mass density ρ . The drop is electrically charged with uniform volume density ρ_e , the total charge being q . We investigate the surface vibrations of the drop under the restoring effect of surface-tension and the disruptive influence of coulomb repulsion. We ignore the effects of the gravitational potential of the drop.

In equilibrium the drop is in a static state with no velocities present and the coulomb potential ϕ_e is related to the charge density ρ_e by the Poisson

equation

$$\nabla^2 \phi_e = -4\pi\rho_e, \quad (\text{II.1})$$

which has the solutions

$$\phi_e = q/r \quad r \geq R$$

and

$$\phi_e = 2\pi\rho_e \left(R^2 - \frac{1}{3}r^2 \right) \quad r \leq R \quad (\text{II.2})$$

Let us now perturb the drop from its equilibrium configuration so that the surface of the drop varies very slightly from the sphere:

$$r_s = R + \varepsilon\xi(\theta, \phi, t) \quad (\text{II.3})$$

where ε is an infinitesimal constant, θ, ϕ the angular coordinates and t the time. Consequently, the charge density and the coulomb potential undergo small perturbations given by ρ'_e and ϕ'_e which are related by the "perturbed" Poisson equation

$$\nabla^2 \phi'_e = -4\pi\rho'_e \quad (\text{II.4})$$

Similarly, the velocity of every point on the surface is now described by a velocity potential ϕ_v which is also a small quantity. Now, in solving the stability problem we note two features of the usual formalism. First, since the perturbations in the variables are assumed to be small, only the first order terms in ε are retained and the higher order terms ignored. This is the process of linearizing the equations. Secondly, the system is said to be stable only if it is stable against all possible perturbations. This condition is easily satisfied by choosing for the perturbation a complete set of normal modes into which any arbitrary perturbation can be decomposed. The choice of a suitable set of normal modes is dictated by the symmetry of the unperturbed system. Similarly, as the variables describing the initial equilibrium state are independent of time, the time-dependence of the perturbations can be expressed simply as $\exp(-i\omega t)$ where ω is the frequency of a particular

mode of oscillations. In the present case, because of the spherical geometry, we can assume

$$\xi = e^{-i\omega t} Y_{\ell m}(\theta\phi) \quad (\text{II.5})$$

where $Y_{\ell m}(\theta\phi)$ is the spherical harmonic of angular momentum ℓ with projection on z-axis given by m . The equation governing the velocity potential ϕ_v is

$$\nabla^2 \phi_v = 0,$$

which has the solution

$$\phi_v = C e^{-i\omega t} r^\ell Y_{\ell m},$$

where the constant C is determined by equating the normal gradient of ϕ_v to the time derivative of the displacement ξ at $r = R$, so that

$$\phi_v = -\frac{i\omega \epsilon R}{\ell} \left(\frac{r}{R}\right)^\ell e^{-i\omega t} Y_{\ell m} \quad (\text{II.6})$$

Next, the perturbation in the charge density can be written as

$$\rho'_e = \epsilon \delta(r-R) \rho_e e^{-i\omega t} Y_{\ell m} \quad (\text{II.7})$$

Assuming

$$\phi'_e = \epsilon \rho_e f(r) e^{-i\omega t} Y_{\ell m} \quad (\text{II.8})$$

the equation (II.4) reduces to

$$\frac{1}{r^2} \frac{d}{dr} r^2 \frac{df}{dr} - \frac{\ell(\ell+1)}{r^2} f = -4\pi\delta(r-R) \quad (\text{II.9})$$

Noting that the delta function gives rise to a discontinuity of 4π in the first derivative $\frac{df}{dr}$ at $r = R$ and from the solutions for $f(r)$ of the homogeneous form of equation (II.9) we obtain

$$f(r) = \frac{4\pi R}{2\ell+1} \left(\frac{r}{R}\right)^\ell \quad r \leq R$$

and

$$f(r) = \frac{4\pi R}{2\ell+1} \left(\frac{R}{r}\right)^{\ell+1} \quad r \geq R$$

so that

$$\phi'_e \Big|_R = \frac{\epsilon 4\pi \rho_e R}{2\ell+1} e^{-i\omega t} Y_{\ell m} \quad (\text{II.10})$$

Thus we have been able to find the solutions for all the perturbed variables from the linearized equations and evaluated their values at the surface. The frequency ω can now be found from the boundary condition at the surface of the drop

$$\rho \frac{\partial \phi}{\partial t} + p + \rho_e \phi_e + \rho_e \phi'_e = 0 \quad (\text{II.11})$$

The pressure p at the surface is given by ¹⁵

$$p = p_o + \alpha \left(\frac{1}{R_1} + \frac{1}{R_2} \right) \quad (\text{II.12})$$

where p_o is the constant external pressure, α the surface tension coefficient and R_1, R_2 are the principal radii of curvature at a given point of the surface. The sum $\left(\frac{1}{R_1} + \frac{1}{R_2} \right)$ is computed as follows:

The area of the surface under consideration is given by

$$S = \int_0^{2\pi} \int_0^\pi \left[r_s^2 + \left(\frac{\partial r_s}{\partial \theta} \right)^2 + \frac{1}{\sin^2 \theta} \left(\frac{\partial r_s}{\partial \phi} \right)^2 \right]^{1/2} r_s \times \sin \theta d\theta d\phi$$

Substituting $r_s = R + \xi$ (here ϵ has been absorbed into ξ for convenience)

and remembering that ξ is small we obtain

$$S = \int_0^{2\pi} \int_0^\pi \left\{ (R+\xi)^2 + \frac{1}{2} \left[\left(\frac{\partial \xi}{\partial \theta} \right)^2 + \frac{1}{\sin^2 \theta} \left(\frac{\partial \xi}{\partial \phi} \right)^2 \right] \right\} \sin \theta d\theta d\phi$$

The area is varied by δS when ξ changes by $\delta \xi$ and is given by

$$\delta S = \int_0^{2\pi} \int_0^\pi \left\{ 2(R+\xi)\delta \xi + \frac{\partial \xi}{\partial \theta} \frac{\partial \delta \xi}{\partial \theta} + \frac{1}{\sin^2 \theta} \frac{\partial \xi}{\partial \phi} \frac{\partial \delta \xi}{\partial \phi} \right\} \sin \theta d\theta d\phi$$

Integration of the second term by parts with respect to θ , and of the third by parts with respect to ϕ yields.

$$\delta S = \int_0^{2\pi} \int_0^\pi \left\{ 2(R+\xi) - \frac{1}{\sin \theta} \frac{\partial}{\partial \theta} (\sin \theta \frac{\partial \xi}{\partial \theta}) - \frac{1}{\sin^2 \theta} \left(\frac{\partial^2 \xi}{\partial \phi^2} \right) \right\} \times \delta \xi \sin \theta d\theta d\phi$$

In terms of the radii of curvature we have also the expression for δS given by

$$\delta S = \int \left(\frac{1}{R_1} + \frac{1}{R_2} \right) dS \delta \xi$$

where dS is the surface element

$$\begin{aligned} dS &= (R+\xi)^2 \sin\theta d\theta d\phi \\ &\approx R(R+2\xi) \sin\theta d\theta d\phi \end{aligned}$$

Comparing the two expressions for δS above we finally obtain

$$\frac{1}{R_1} + \frac{1}{R_2} = \frac{2}{R} - \frac{2\xi}{R^2} - \frac{1}{R^2} \left\{ \frac{1}{\sin^2\theta} \frac{\partial^2 \xi}{\partial \phi^2} + \frac{1}{\sin\theta} \frac{\partial}{\partial \theta} \left(\sin\theta \frac{\partial \xi}{\partial \theta} \right) \right\} \quad (\text{II.13})$$

Before working out the boundary condition (II.11) we note that

$$\phi_e|_{\text{surf}} = \phi_e|_R + \varepsilon \left(\frac{\partial \phi}{\partial r} \right)_e \xi \quad (\text{II.14})$$

up to first order in ε . If we now substitute for the various quantities in equation (II.11), the zero-order terms give the boundary condition satisfied by the equilibrium configuration. By collecting the terms multiplied by ε after substituting the results of equations (II.5), (II.6), (II.10), (II.12) and (II.14), and using the relation

$$\frac{1}{\sin\theta} \frac{\partial}{\partial \theta} \left(\sin\theta \frac{\partial Y_{\ell m}}{\partial \theta} \right) + \frac{1}{\sin^2\theta} \frac{\partial^2 Y_{\ell m}}{\partial \phi^2} + \ell(\ell+1) Y_{\ell m} = 0,$$

we obtain the equation for the frequency:

$$\rho \frac{(-i\omega)^2}{\ell} R + \alpha \left[-\frac{2}{R^2} + \frac{\ell(\ell+1)}{R^2} \right] + \frac{4\pi\rho_e^2}{2\ell+1} - \frac{4\pi}{3}\rho_e^2 = 0$$

where we have cancelled the coefficient $\varepsilon e^{-i\omega t} Y_{\ell m}$ throughout. Or

$$\omega^2 = \frac{4\pi\alpha\ell}{M} \left[(\ell-1)(\ell+2) - 10\gamma \frac{(\ell-1)}{2\ell+1} \right] \quad (\text{II.15})$$

Here γ is the ratio of the coulomb energy $E_c = 3/5 q^2 R^{-1}$ and the surface energy $E_s = 4\pi R^2 \alpha$.

The mode with $\ell = 0$ is clearly impossible since this corresponds to radial pulsations which are inconsistent with incompressibility. The dipole mode $\ell = 1$ represents a rigid translation of the drop as a whole. For higher ℓ values the sign of ω^2 depends on that of the expression

$$\left[(\ell+2) - \frac{10\gamma}{2\ell+1} \right].$$

If γ is sufficiently small then ω^2 can be positive for all values of ℓ and the time dependence of each mode is purely oscillatory. The important thing to note is that the drop is inherently stable if it is stable against any initial perturbation. Since the functions $Y_{\ell m}(\theta, \phi)$ form a complete set any such perturbation can be expanded as

$$\xi(\theta, \phi, t = 0) = \sum_{\ell, m} a_{\ell m} Y_{\ell m}(\theta, \phi)$$

where $a_{\ell m}$ are constant coefficients. The time development of the initial perturbation will then be

$$\xi(\theta, \phi, t) = \sum_{\ell, m} a_{\ell m} Y_{\ell m}(\theta, \phi) e^{-i\omega_{\ell} t}.$$

If ω_{ℓ} is real for every value of ℓ then the perturbation will not grow with time and the drop is stable. On the other hand, if for some ℓ the frequency ω_{ℓ} is imaginary, then since one can always find an initial perturbation which will have to contain the mode corresponding to this frequency and since the drop will be unstable against this perturbation we conclude that the drop is inherently unstable. This would be the case for γ high enough to make ω^2 negative for one or more values of ℓ .

We have tried to emphasize the importance of the completeness of the set of functions that are used to expand the initial perturbation. In the present example where only the functions $Y_{\ell m}(\theta, \phi)$ enter into such an expansion - and where the completeness of these functions is a well established fact - the

importance of this requirement is not obvious enough. When we consider the stability of the Schwarzschild metric from a rigorous point of view (Chapter V) which is a much more complicated problem, the requirement of completeness of the set of functions corresponding to real frequencies becomes a crucial point.

We shall now consider the Regge-Wheeler treatment of the stability of the Schwarzschild metric which is formally similar to the example considered in this section.

B. Regge-Wheeler Approach to the Stability of the Schwarzschild Metric

The Schwarzschild metric is written in its usual form as

$$ds^2 = - \left(1 - \frac{2m}{r}\right) dt^2 + \left(1 - \frac{2m}{r}\right)^{-1} dr^2 + r^2(d\theta^2 + \sin^2\theta d\phi^2) = g_{\mu\nu} dx^\mu dx^\nu \quad (\text{II.16})$$

with

$$x^0 = t, \quad x^1 = r, \quad x^2 = \theta, \quad x^3 = \phi \quad \text{and} \quad c = G = 1$$

This corresponds to the initial time-independent equilibrium configuration. The problem is, then, if this metric is perturbed, whether the perturbations will execute undamped oscillations about the equilibrium state represented by the Schwarzschild background (stability) or will grow exponentially with time (instability). In order to answer this question the procedure similar to the one outlined in the previous section is followed, so that one has to consider:

(1) Perturbations: Regge and Wheeler have given the normal modes into which any arbitrary perturbation on a spherically symmetric background can be decomposed. The explicit forms of these modes will be given in the next chapter. Here we note a few properties of these normal modes. These can be expressed in the form of products of four factors each of which is a function of one of the coordinates t , r , θ and ϕ ; this separation is achieved by the use of generalized tensor spherical harmonics. Associated with any of these modes we have the

angular momentum ℓ and its projection on the z-axis M . For simplicity one can choose $M = 0$, as the particular value of M chosen does not alter the final results. For any given value of ℓ there are two independent classes of perturbation characterized by their parities $(-1)^\ell$ and $(-1)^{\ell+1}$ which are designated as the "even" and "odd" parity perturbations. Furthermore, a great degree of simplification in the form of the perturbation matrix can be achieved by making suitable gauge transformations which will reduce the general perturbation to the Regge-Wheeler canonical form which will have fewer matrix elements than the former. All calculations will be carried out in the canonical gauge. Finally, as has been mentioned before, the time dependence of the perturbations is given by $\exp(-ikt)$, since the background is independent of time.

(2) Field Equations: The next step in the analysis of the stability problem is to obtain the equations governing the above perturbations. Let us denote the Schwarzschild background metric by $g_{\mu\nu}$ and the superimposed perturbation by $h_{\mu\nu}$. The Einstein field equations for the Schwarzschild exterior metric are given by

$$R_{\mu\nu}(g) = 0$$

Here the Ricci tensor $R_{\mu\nu}$ has been computed from the Schwarzschild background-metric $g_{\mu\nu}$ and this is indicated by the g in the parentheses. For the perturbed space-time the field equations would read

$$R_{\mu\nu}(g+h) = 0$$

where the computations are carried out using the total metric $g_{\mu\nu} + h_{\mu\nu}$. Here we have made the assumption that the perturbed space-time is still empty. Since the perturbations are assumed to be small so that the second and higher order terms in $h_{\mu\nu}$ can be neglected, the above equations can be expanded as

$$R_{\mu\nu}(g) + \delta R_{\mu\nu}(h) = 0$$

where $\delta R_{\mu\nu}(h)$ contain only the first order terms in $h_{\mu\nu}$. Since $R_{\mu\nu}(g) = 0$, the differential equations governing the perturbations are obtained from the equations $\delta R_{\mu\nu}(h) = 0$. In order to compute $\delta R_{\mu\nu}$, the formulas given by Eisenhart⁹ are employed:

$$\delta R_{\mu\nu} = -\delta\Gamma_{\mu\nu;\beta}^{\beta} + \delta\Gamma_{\mu\beta;\nu}^{\beta} \quad (\text{II.17})$$

Here the semicolons denote covariant differentiation and the variation in the Christoffel symbol $\delta\Gamma_{\mu\nu}^{\beta}$ stands for the expression;

$$\delta\Gamma_{\mu\nu}^{\beta} = \frac{1}{2} g^{\beta\alpha} (h_{\mu\alpha;\nu} + h_{\nu\alpha;\mu} - h_{\mu\nu;\alpha}). \quad (\text{II.18})$$

The differential equations thus obtained will contain the frequency k as a constant parameter. As shown in the appendix A, starting from these equations, which are coupled in the radial factors of the perturbations, a single second order linear differential equation containing only one radial factor can be derived both in the odd and the even parity cases. The final task will then be to analyze this differential equation and see whether the frequency k can be purely imaginary or not. Before this can be done we must formulate the proper boundary conditions for the perturbations.

(3) Boundary Conditions: The boundary conditions originally formulated by Regge and Wheeler are as follows. The two boundaries chosen are the spatial infinity and the Schwarzschild surface $r = 2m$. A physically acceptable perturbation should be well behaved at both these points at the starting instant. In the first place, the perturbations were required not to diverge for large values of r . Secondly, in order to impose the boundary condition at $r = 2m$, the Schwarzschild space was visualized as "inwardly unbounded" and considered as "one mouth of a wormhole, the other mouth of which emerged elsewhere". With this representation of the Schwarzschild space, it was demanded that one should be able to join the solution for $r \geq 2m$ smoothly onto a solution in the other

half of the tunnel. The authors claimed that the solution that vanished for large r also went to zero at the Schwarzschild radius, so that the above requirement could not be satisfied. However, as we shall see in the next chapter, the solutions that go to zero at spatial infinity do not fall off at $r = 2m$, but, on the contrary, diverge as expressed in the Schwarzschild coordinates. Moreover, as pointed out in the first chapter, since the background metric itself contains an apparent singularity at $r = 2m$, the behaviour of a perturbation - divergent or otherwise - as expressed in the Schwarzschild coordinates is liable to be spurious and unphysical. We must therefore formulate and apply the boundary condition at $r = 2m$ within the frame work of a coordinate system which is singularity-free at that point. This we shall do employing the Kruskal coordinates. Before that, however, we shall briefly discuss the gravitational collapse of a spherical mass and the consequent production of the Schwarzschild empty space geometry beyond $r = 2m$.

C. Gravitational Collapse

The free-fall collapse as studied by Oppenheimer and Snyder² assumed idealized conditions of spherically symmetric distribution of matter without rotation, adiabatic flow (i.e., absence of viscosity, heat conduction or radiation), and the simple equation of state $p = 0$. The Einstein field equations could then be integrated analytically and the solutions showed that the mass distribution had no alternative other than to contract progressively to zero volume. The total time of collapse for an observer comoving with the collapsing matter was shown to be finite, whereas to an external observer the spherical mass distribution asymptotically shrank to its gravitational radius. In the following we give an analysis based on the treatments due to Misner and Sharp¹⁰, and Thorne¹.

Consider then a spherical distribution of mass with no pressure, and of initial radius R_i and total mass M . At the instant at which the collapse starts the configuration is in a momentarily static state. Further, as has been noted already the geometry outside the collapsing mass is given by the Schwarzschild exterior metric. Inside the matter¹¹ the stress-energy tensor is that associated with an ideal fluid with zero pressure:

$$T^{\mu\nu} = \epsilon u^\mu u^\nu, \quad (\text{II.19})$$

where u^μ is the four-velocity of the fluid, ϵ is the internal energy of the fluid per unit proper rest volume. The metric is written in the diagonal form¹²

$$ds^2 = - e^{2\phi} dt^2 + e^\lambda dr^2 + R^2(d\theta^2 + \sin^2\theta d\phi^2), \quad (\text{II.20})$$

where ϕ , λ , and R are functions of r and t . The computations are carried out in the comoving coordinates, i.e., a system of coordinates moving at each point with the material located at that point. The four-velocity is then given by

$$u^\mu = (e^{-\phi}, 0, 0, 0). \quad (\text{II.21})$$

Now, define the comoving proper-time derivative D_t by

$$D_t = u^\mu \frac{\partial}{\partial x^\mu} = e^{-\phi} \left(\frac{\partial}{\partial t} \right)_r \quad (\text{II.22})$$

Similarly, define U which gives the relative velocity $Ud\theta$ of adjacent particles on the sphere of constant r ,

$$U = D_t R = e^{-\phi} \dot{R}$$

where the dot denotes differentiation with respect to t .

The Einstein field equations can then be written simply as

$$D_t R = U \quad (\text{II.23})$$

$$D_t U = - \frac{m}{R^2} \quad (\text{II.24})$$

$$D_t m = 0 \quad (\text{II.25})$$

$$\left(\frac{\partial m}{\partial R} \right)_t = 4\pi R^2 \epsilon \quad (\text{II.26})$$

Here the function $m(r,t)$ is defined by the relation

$$e^\lambda = \left[1 + U^2 - \frac{2m(r,t)}{R} \right]^{-1} \left(\frac{\partial R}{\partial r} \right)^2 \quad (\text{II.27})$$

Equation (II.25) and (II.26) show that m is independent of t and can be expressed as

$$m = \int_0^r 4\pi R^2 \epsilon dR.$$

We shall discuss the significance of m shortly. Next, the boundary of the collapsing matter is given by $r = r_b = \text{constant}$. At this surface the interior metric should be matched smoothly onto the Schwarzschild exterior metric.

$$ds^2 = - \left(1 - \frac{2M}{R} \right) dt^2 + \left(1 - \frac{2M}{R} \right)^{-1} dR^2 + R^2 (d\theta^2 + \sin^2\theta d\phi^2).$$

The boundary can also be described by the equation

$$R = R_b(t)$$

Equating the expression for the line element on the boundary surface we obtain

$$\begin{aligned} (ds^2)_b &= - \left(1 - \frac{2M}{R_b} \right) dt^2 + \frac{R_b^2 dt^2}{\left(1 - \frac{2M}{R_b} \right)} + R_b^2 (d\theta^2 + \sin^2\theta d\phi^2) \\ &= - (e^{2\phi})_b dt^2 + R^2(r_b, t) (d\theta^2 + \sin^2\theta d\phi^2), \end{aligned} \quad (\text{II.28})$$

where the subscript b indicates that the quantities are evaluated on the boundary. If we demand that the interior and exterior time coordinates agree on the surface, we obtain an equation for the interface in the exterior coordinates:

$$R = R_b(t) = R(r_b, t).$$

Also we have the condition

$$(e^\phi)_{r=r_b} = \left(1 - \frac{2M}{R_b}\right) \left(1 + U_b^2 - \frac{2M}{R_b}\right)^{-1/2} \quad (\text{II.29})$$

In the foregoing we have shown that it is possible, by suitably choosing the coordinates, to match the metric components $g_{\mu\nu}$ smoothly across the interface. In order to ensure that the first derivatives of the metric components are matched smoothly it is sufficient that the second fundamental form¹³ $\Phi = (-n_{\mu;\nu} dx^\mu dx^\nu)_b$ be the same whether the boundary surface is viewed as imbedded in the interior or the exterior geometry. Here n^μ is the unit normal to the surface and the subscript b indicates that one of the coordinate differentials has been eliminated using the equation of the surface. The equations of the boundary surface are

$$(dR - \dot{R} dt)_b = 0$$

and

$$r = r_b$$

in the exterior and the interior metrics respectively. By matching the second fundamental form one gets the condition¹⁰

$$M = m(r_b).$$

Thus $m(r_b)$ is in fact the total Schwarzschild mass of the collapsing matter. To sum up, we can choose coordinates such that the interior metric matches on smoothly to the exterior metric at the boundary surface and we shall later use the limiting form of the exterior metric on the boundary to study the dynamics of the collapse.

Next, since every material particle is in free fall, the associated four-velocity satisfies the geodesic equation

$$u^\mu{}_{;\nu} u^\nu = 0$$

The r -component of this equation yields the result

$$\frac{\partial \phi}{\partial r} = 0$$

Hence e^ϕ is a function of t only. Then it is possible to redefine the time coordinate such that the metric component $g_{tt} = 1$. This will synchronize the interior time with the proper time of a comoving observer at the boundary surface $r = r_b$ and guarantees that the interior time coordinate will not reflect the singularities of the exterior time coordinate as the surface enters the Schwarzschild horizon $R_s(t) = 2M$. Finally, if we choose the time coordinate so as to make $g_{tt} = 1$, then

$$D_t = \left(\frac{\partial}{\partial t} \right)_r$$

and

$$U = \dot{R}$$

The field equation (II.24) reduces to

$$\ddot{R} + \frac{m}{R^2} = 0. \quad (\text{II.30})$$

We at once get the first integral

$$\frac{1}{2} \dot{R}^2 - \frac{m}{R} = E = \text{const} \quad (\text{II.31})$$

which describes the Newtonian free fall for $R(t)$ since $m(t)$ is constant.

We now turn our attention to the surface of the collapsing mass and follow its evolution¹⁴. We first derive the energy red shift formula in a static metric. This we shall do in a coordinate independent way using the time-like Killing vector associated with the static metric. This technique is further extended in Appendix B and a generalization of the Schwarzschild surface to arbitrary static and stationary metric is given.

Now, a static metric admits a time-like Killing vector field ξ^μ satisfying

the Killing equation

$$\xi_{\mu;\nu} + \xi_{\nu;\mu} = 0 \quad (\text{II.31})$$

We can define "static" observers or sources as those with four-velocities given by

$$v^\mu = (-\xi_\nu \xi^\nu)^{-1/2} \xi^\mu ; \quad v^\mu v_\mu = -1, \quad (\text{II.32})$$

where we have taken the signature of the metric as $(-, +, +, +)$. If we now consider a particle following a geodesic with four-velocity u^μ , then the product $u^\mu \xi_\mu$ is constant along the geodesic, since

$$(u^\mu \xi_\mu)_{;\nu} u^\nu = u^\mu_{;\nu} u^\nu \xi_\mu + \xi_{\mu;\nu} u^\mu u^\nu = 0 \quad (\text{II.33})$$

The first term is zero because of the geodesic equation $u^\mu_{;\nu} u^\nu = 0$; the second term vanishes on account of the antisymmetry of $\xi_{\mu;\nu}$. Hence, at two points 1 and 2,

$$\frac{(u^\mu v_\mu)_1}{(u^\nu v_\nu)_2} = \frac{(-\xi^\mu \xi_\mu)_2^{1/2}}{(-\xi^\mu \xi_\mu)_1^{1/2}},$$

or the product $(u^\mu v_\mu) (-\xi^\nu \xi_\nu)^{1/2} = \text{constant}$. For a particle of mass μ the four-momentum p^ν is given by $p^\nu = \mu u^\nu$ and the above result can be written as

$$(p^\mu v_\mu) (-\xi^\nu \xi_\nu)^{1/2} = \text{constant} \quad (\text{II.34})$$

If the coordinates chosen are such that the metric is time-independent then

$$\xi^\mu = (1, 0, 0, 0) ; \quad \xi^\mu \xi_\mu = g_{00}$$

and $p^\mu v_\mu = -E$, the energy of the particle as measured by a static observer.

Then the equation (II.34) can be written as

$$E (-g_{00})^{1/2} = \text{constant} \quad (\text{II.35})$$

Let us apply this equation to a particle of mass μ attached to the surface

of the collapsing matter. Since the matter is in a state of free fall collapse the particle traces out a geodesic with the instantaneous velocity u which is the same as that of the surface. Its velocity at $R = R_i$ is zero since the contraction starts from a momentarily static state, so that equation (II.35) reads

$$(1 - u^2)^{-1/2} (g_{00})_{R_b} = \text{constant} = (g_{00})_{R_i} \quad (\text{II.36})$$

where $R = R_b(t)$ is the surface of the collapsing mass. Also

$$u = \left(1 - \frac{2M}{R_b}\right)^{-1} \frac{dR_b}{dt} \quad (\text{II.37})$$

Combining equations (II.36) and (II.37) we obtain

$$\frac{dR_b}{dt} = - \left(\frac{2M}{R_i - 2M}\right)^{1/2} \left(\frac{R_i}{R_b} - 1\right)^{1/2} \left(1 - \frac{2M}{R_b}\right)$$

The solution to this equation has the parametric form:

$$\begin{aligned} R_b &= \left(\frac{R_i}{2}\right) (1 + \cos\eta) \\ t &= 2M \ln \left[\frac{\left(\frac{R_i}{2M} - 1\right)^{1/2} + \tan\left(\frac{\eta}{2}\right)}{\left(\frac{R_i}{2M} - 1\right)^{1/2} - \tan\left(\frac{\eta}{2}\right)} \right] \\ &\quad + 2M \left(\frac{R_i}{2M} - 1\right)^{1/2} \left[\eta + \left(\frac{R_i}{4M}\right) (\eta + \sin\eta) \right] \end{aligned} \quad (\text{II.38})$$

The proper time measured in the frame comoving with the surface is given by

$$\begin{aligned} \tau &= \int_0^t \left[\left(1 - \frac{2M}{R_b}\right) dt^2 - \left(1 - \frac{2M}{R_b}\right)^{-1} dR_b^2 \right]^{1/2} \\ &= \left(\frac{R_i^3}{8M}\right)^{1/2} (\eta + \sin\eta) \end{aligned}$$

As the Schwarzschild time t increases the derivative $\frac{dR_b}{dt}$ decreases and in the limit as t tends to ∞ , i.e., when $\tan\left(\frac{\eta}{2}\right) = \left(\frac{R_i}{2M} - 1\right)^{1/2}$, R_b assumes the asymptotic value of $2M$. On the other hand the proper time measured by

the comoving observer to cross the Schwarzschild horizon $R = 2M$ remains finite and is given by

$$\tau(r_b = 2M, t = \infty) = \left(\frac{R_i^3}{8M}\right)^{1/2} \cos^{-1} \left(\frac{4M}{R_i} - 1\right) + R_i \left(1 - \frac{2M}{R_i}\right)^{1/2} \quad (\text{II.39})$$

Again the comoving time to reach the singularity $r = 0$ is finite:

$$\tau(R_b = 0, \eta = \pi) = \pi \left(\frac{R_i^3}{8M}\right)^{1/2} \quad (\text{II.40})$$

To summarize, a spherical distribution of matter, which cannot sustain itself against its gravitational field, progressively collapses until its volume reduces to zero. The whole process takes place in a finite interval of proper time as measured by an observer comoving with the contracting mass. An external observer, however, sees the collapse slow down progressively as the surface moves towards the gravitational radius and will asymptotically coalesce with the Schwarzschild horizon after an infinitely long lapse of time. To him the end product of the whole process is the spherically symmetric empty space extending from the surface $r = 2M$ to spatial infinity. At the same time, he is left with the Schwarzschild horizon which seems to be highly pathological. This behaviour, fortunately, is only the result of a wrong choice of coordinates especially in the neighborhood of the Schwarzschild surface. Of the several coordinate systems that remedy the situation, the most widely adopted is due to Kruskal. We now proceed to examine some aspects of this system of coordinates, which are relevant to our problem of stability.

D. Kruskal Coordinates

In the Kruskal coordinates the Schwarzschild line element can be written as

$$ds^2 = f^2 (dv^2 - du^2) - r^2 (d\theta^2 + \sin^2\theta d\phi^2) \quad (\text{II.41})$$

with

$$f^2 = \left(\frac{32m^3}{r} \right) \exp(-r/2m)$$

The coordinates u and v are related to the Schwarzschild coordinates r and t by:

$$\begin{aligned} u &= \left(\frac{r}{2m} - 1 \right)^{1/2} \exp(r/4m) \cosh(t/4m) \\ v &= \left(\frac{r}{2m} - 1 \right)^{1/2} \exp(r/4m) \sinh(t/4m) \end{aligned} \quad \text{for } r > 2m$$

and

(II.42)

$$\begin{aligned} u &= \left(1 - \frac{r}{2m} \right)^{1/2} \exp\left(\frac{r}{4m} \right) \sinh(t/4m) \\ v &= \left(1 - \frac{r}{2m} \right)^{1/2} \exp\left(\frac{r}{4m} \right) \cosh(t/4m) \end{aligned} \quad \text{for } r < 2m$$

Then

$$\left(\frac{r}{2m} - 1 \right) \exp(r/2m) = u^2 - v^2$$

and

$$\frac{t}{4m} = \text{arc tanh}(v/u)$$

From the above relations it is clear that curves of constant radius r are represented by hyperbolae $u^2 - v^2 = \text{constant}$ in the $u - v$ plane of the Kruskal diagram and similarly curves of constant time t are the radial lines $v/u = \text{constant}$. The points $(r = 2m, t = \infty)$ and $(r = 2m, t = -\infty)$ go over now to the lines $u = v$ and $u = -v$ respectively. Radial light rays travel along 45 degree lines given by $\frac{dv}{du} = \pm 1$. The coordinate singularity at $r = 2m$ is completely removed and the metric remains finite up to the physical singularity $r = 0$.

In Figure 1 we have depicted on the Kruskal diagram the collapse of a spherical mass, the collapse having started at some finite time in the past (the present instant is taken as $t = 0$, so that the past corresponds to negative values of t). The broken line represents the time-like world line traced by

the collapsing surface of the star. Let us see how this would be modified if we assume that the collapse started somewhat earlier than in the first case. This can be done easily by making a time translation $t \rightarrow t - T$ and tracing how a given point on the world line of the surface moves to a new position. Under this transformation a point $P(u,v)$ on the Kruskal diagram shifts to a new point $P'(u',v')$ given by

$$u' = u \cosh\left(\frac{T}{4m}\right) - v \sinh\left(\frac{T}{4m}\right),$$

$$v' = -u \sinh\left(\frac{T}{4m}\right) + v \cosh\left(\frac{T}{4m}\right),$$

a transformation which leaves the line element unchanged. First we note that

$$(u')^2 - (v')^2 = u^2 - v^2,$$

so that under the time translation the point moves along the hyperbola of constant r given by $u^2 - v^2 = \text{constant}$. Consider, for example, a point in quadrant I with $u > 0$, $v > 0$ and $u > v$. Since $\cosh(T/4m) > \sinh(T/4m)$ for all finite values of T , u' remains always positive (this is true even in the limit of T going to infinity when $\sinh(T/4m)$ approaches $\cosh(T/4m)$ asymptotically). On the other hand v' starts with a positive value and becomes more and more negative as T is increased. Thus the point $P(u,v)$ travels "downward" along the hyperbola moving progressively closer to the line $u = -v$. We can consider the shift of other points on the world line of the surface to obtain its new position which is shown as the solid line in figure 1. The region to the left of this line (the hatched region) should be replaced by an appropriate space-time geometry for the interior of the matter and the unstriped region represents the Schwarzschild exterior surrounding the matter. In the limit of T tending to infinity the world line of the surface coalesces with the line $u = -v$. Therefore, if a spherical mass has collapsed in the remote past producing the Schwarzschild exterior down to $r = 2m$, then the situation is depicted on the Kruskal diagram (figure 2) by the

matter lying to the left of the line $u = -v$ and the empty space represented by the region to the right of this line with the line itself corresponding to the surface of the collapsed mass. We can now employ this picture in analyzing the perturbations on the Schwarzschild background.

E. Perturbation Analysis in Kruskal Coordinates:

Since the metric is regular everywhere in the Kruskal coordinates, the correct way to analyze the perturbations is to study them in those coordinates. If we were to work out the perturbation theory entirely in the Kruskal coordinates, we would find that the perturbations have the same angular dependence as the perturbations in the Schwarzschild coordinates, since the two systems have the same angular coordinates, and the canonical forms of the perturbations would have the same nonvanishing matrix elements. Nevertheless, in place of the radial functions we would have functions of both u and v i.e. of both r and t . If we worked out the field equations and imposed regularity conditions on the solutions only certain classes of these solutions would emerge as the allowed perturbations. Whether these include unstable solutions will have to be decided by transforming to the Schwarzschild coordinates where the time dependence is simply $\exp(-ikt)$. It is evident that this is indeed a formidable task. Instead we work out the field equations and find the solutions in the Schwarzschild coordinates, and transform them to Kruskal coordinates which is equivalent to the other alternative outlined above. These Kruskal transforms should be regular over the entire region that represents the empty space beyond $h = 2m$ on the Kruskal diagram, i.e. the region between the lines $u = \pm v$. However, at spatial infinity the u and v coordinates are not suitable for our purpose since they do not form a Lorentz frame whereas we require the space to be asymptotically flat in this region. Therefore we first select the solutions that fall off to zero for large values of r in the Schwarzschild coordinates, find their asymptotic forms near $r = 2m$ and transform them to Kruskal coordinates. We

shall then study whether these transforms diverge or are well behaved. A perturbation giving rise to such a divergence -- a divergence which can not be removed -- is forbidden; if not it is a perfectly valid perturbation that can have physical existence. We shall see that perturbations with purely imaginary frequencies do produce divergent Kruskal transforms. Hence such unstable perturbations do not exist and the Schwarzschild geometry is inherently stable against small perturbations.

CHAPTER III

THE STABILITY OF THE SCHWARZSCHILD METRIC - NAIVE VIEWPOINT

In this chapter we shall solve the problem originally posed by Regge and Wheeler. The perturbations on the Schwarzschild metric can be represented by normal modes with time dependence $\exp(-ikt)$. Suppose one of these modes is superimposed upon the background metric at the initial moment $t = 0$ and it is regular everywhere in space. Can the frequency of this perturbation be purely imaginary? If so it will grow progressively in time showing that the metric is inherently unstable. On the other hand, if it is found that the perturbation that is regular in all space at the initial instant must necessarily have real frequency, then the metric is stable. We shall show that this is precisely the situation. We emphasize the fact already mentioned in the last chapter: the regularity of the initial perturbation should be checked in the Kruskal coordinates in which the background metric itself is free of singularity. A study of the field equations and the asymptotic behaviour of their solutions will show that this condition is not satisfied by perturbations with imaginary frequencies.

We shall first write down the most general representation of the perturbations as well as their canonical form. Next the Kruskal transforms corresponding to the canonical perturbations are given in order to examine later their asymptotic behaviour near the Schwarzschild surface. The rest of the chapter will be devoted to the analysis of the first order field equations for the perturbations corresponding to purely real and imaginary frequencies.

A. Perturbations in the Schwarzschild Coordinates:

The total perturbed metric may be written as

$$g_{\mu\nu}^t = g_{\mu\nu} + h_{\mu\nu}$$

where $g_{\mu\nu}$ is the Schwarzschild background metric and $h_{\mu\nu}$ is the small perturbation. We use the same perturbations $h_{\mu\nu}$ as originally given by Regge and Wheeler, retaining their notation. These fall into two distinct classes - odd and even - with parities $(-1)^{\ell+1}$ and $(-1)^\ell$ respectively, where ℓ is the angular momentum of the particular mode. The most general form of the perturbations can be written as:

Odd parity:

$$h_{\mu\nu} = \left| \begin{array}{cc} 0 & 0 \\ 0 & 0 \\ \text{Sym Sym} & \text{Sym} \\ \text{Sym Sym} & \end{array} \right. \begin{array}{l} -h_0(t,r)(\partial/\sin\theta\partial\phi)Y_\ell^M \\ -h_1(t,r)(\partial/\sin\theta\partial\phi)Y_\ell^M \\ h_2(t,r)(\partial^2/\sin\theta\partial\theta\partial\phi - \cos\theta\partial/\sin^2\theta\partial\phi)Y_\ell^M \\ \frac{1}{2}h_2(t,r)(\partial^2/\sin\theta\partial\phi\partial\phi + \cos\theta\partial/\partial\theta - \sin\theta\partial^2/\partial\theta\partial\theta)Y_\ell^M \end{array} \left. \begin{array}{l} h_0(t,r)(\sin\theta\partial/\partial\theta)Y_\ell^M \\ h_1(t,r)(\sin\theta\partial/\partial\theta)Y_\ell^M \\ \text{Sym} \\ -h_2(t,r)(\sin\theta\partial^2/\partial\theta\partial\phi - \cos\theta\partial/\partial\phi)Y_\ell^M \end{array} \right| \quad (\text{III.1})$$

Even Parity:

$$h_{\mu\nu} = \left| \begin{array}{cccc} (1-\frac{2m}{r})H_0(t,r)Y_\ell^M & H_1(t,r)Y_\ell^M & h_0(t,r)(\partial/\partial\theta)Y_\ell^M & h_0(t,r)(\partial/\partial\phi)Y_\ell^M \\ H_1(t,r)Y_\ell^M & (1-\frac{2m}{r})^{-1}H_2(t,r)Y_\ell^M & h_1(t,r)(\partial/\partial\theta)Y_\ell^M & h_1(t,r)(\partial/\partial\phi)Y_\ell^M \\ \text{Sym} & \text{Sym} & r[K(t,r) \\ +G(t,r)(\partial^2/\partial\theta^2)]Y_\ell^M & \text{Sym} \\ \text{Sym} & \text{Sym} & r^2G(tr,)(\partial^2/\partial\theta\partial\phi - \cos\theta\partial/\sin\theta\partial\phi)Y_\ell^M & r^2[K(t,r)\sin^2\theta \\ +G(t,r)(\partial^2/\partial\phi\partial\phi + \sin\theta\cos\theta\partial/\partial\theta)]Y_\ell^M \end{array} \right| \quad (\text{III.2})$$

where y_ℓ^M are spherical harmonics with angular momentum ℓ and its z-component M . As has been mentioned earlier, one can specialize to the case with $M = 0$ without altering the physics of the situation. The time dependence of the perturbations is given by $\exp(-ikt)$, the constant k being the frequency. Further by suitable

gauge transformations the number of elements in the perturbation matrix can be reduced thereby obtaining the canonical form for the perturbations given by:

Odd Parity:

$$h_{\mu\nu} = \begin{vmatrix} 0 & 0 & 0 & h_0(r) \\ 0 & 0 & 0 & h_1(r) \\ 0 & 0 & 0 & 0 \\ \text{Sym} & \text{Sym} & 0 & 0 \end{vmatrix} \exp(-ikt) (\sin\theta \frac{\partial}{\partial\theta}) P_\ell(\cos\theta) \quad (\text{III.3})$$

Even Parity:

$$h_{\mu\nu} = \begin{vmatrix} H_0 \left(\frac{1-2m}{r}\right) & H_1 & 0 & 0 \\ H_1 & H_2 \left(\frac{1-2m}{r}\right)^{-1} & 0 & 0 \\ 0 & 0 & r^2 K & 0 \\ 0 & 0 & 0 & r^2 K \sin^2\theta \end{vmatrix} \begin{matrix} \exp(-ikt) \\ P_\ell(\cos\theta) \end{matrix} \quad (\text{III.4})$$

Here $P_\ell(\cos\theta)$ is the Legendre polynomial with angular momentum ℓ .

B. Transformations to the Kruskal Coordinates

The relations between the Schwarzschild and the Kruskal coordinates have been given in the last chapter by equations (II.42). Using the tensor transformation law the canonical perturbations in the Schwarzschild coordinates can be transformed to obtain the corresponding perturbations in the Kruskal coordinates. Since the angular coordinates are common to both of the above frames, the transforms represent the canonical perturbations in the Kruskal coordinates with the Schwarzschild time and radial coordinates mixed through u and v . The Kruskal transforms can be obtained by a straight forward computation and given below are the transforms involving r and t . Components like h_{22} etc., that involve

only angular coordinates are the same in both systems.

$$\begin{aligned}
 h^k_{00} &= f^2(r)(u^2-v^2)^{-1} \left[u^2 \left(1 - \frac{2m}{r}\right)^{-1} h^s_{00} + v^2 h^s_{11} \left(1 - \frac{2m}{r}\right) - 2uv h^s_{01} \right] \\
 h^k_{11} &= f^2(r)(u^2-v^2)^{-1} \left[v^2 \left(1 - \frac{2m}{r}\right)^{-1} h^s_{00} + u^2 h^s_{11} \left(1 - \frac{2m}{r}\right) - 2uv h^s_{01} \right] \\
 h^k_{01} &= f^2(r)(u^2-v^2)^{-1} \left[(u^2+v^2) h^s_{01} - uv \left\{ \left(1 - \frac{2m}{r}\right)^{-1} h^s_{00} + \left(1 - \frac{2m}{r}\right) h^s_{11} \right\} \right] \\
 h^k_{03} &= 4m(u^2-v^2)^{-1} \left[u h^s_{03} - v \left(1 - \frac{2m}{r}\right) h^s_{13} \right] \\
 h^k_{13} &= -4m(u^2-v^2)^{-1} \left[v h^s_{03} - u \left(1 - \frac{2m}{r}\right) h^s_{13} \right]
 \end{aligned} \tag{III.5}$$

where the superscripts s and k refer to the Schwarzschild and Kruskal coordinates respectively. For future reference we give the following relations:

$$e^{r^*/2m} = (u^2-v^2)$$

where r^* is defined by

$$\frac{r^*}{2m} = \frac{r}{2m} + \ln\left(\frac{r}{2m} - 1\right)$$

and

$$t/2m = 2 \tanh^{-1}(v/u) = \ln\left(\frac{u+v}{u-v}\right) \tag{III.6}$$

so that

$$e^{t/2m} = \frac{u+v}{u-v}$$

C. The Odd Parity Perturbations:

We now examine the stability of the Schwarzschild metric against the odd perturbations. The two cases, $\ell > 1$ and $\ell = 1$, will have to be studied separately since the field equations are not the same in these two cases.

Case 1: $\ell > 1$:

For the angular momentum $\ell > 1$ the field equations lead to the "wave equation" [the time dependence of the perturbations is $\exp(-ikt)$]:

$$\frac{d^2 Q}{dr^{*2}} + (k^2 - V_{\text{eff}})Q = 0 \tag{III.7a}$$

where $Q = \frac{h_1}{r} \left(1 - \frac{2m}{r}\right), V_{\text{eff}} = \left(1 - \frac{2m}{r}\right) \left[\frac{\ell(\ell+1)}{r^2} - \frac{6m}{r^3} \right]$ (III.7b)

and r^* is as defined at the end of the preceding section. The radial function h_0 can be found from the equation:

$$h_0 = \frac{i}{k} \frac{d}{dr^*} (rQ) \quad (\text{III.7c})$$

The coordinate r^* ranges from $-\infty$ to $+\infty$ corresponding to the range of r from $2m$ to $+\infty$. The effective potential V_{eff} is real, positive everywhere and vanishes at $r^* = \pm\infty$, i.e. at the boundaries.

First consider the solutions with purely imaginary k , which will give rise to unstable perturbations, i.e. perturbations that grow exponentially with time. Set $k = i\alpha$ where α is real and positive, so that the time dependence of the perturbations becomes $\exp(\alpha t)$. Then the equations (III.7a) and (III.7c) read:

$$\frac{d^2 Q}{dr^{*2}} = (\alpha^2 + V_{\text{eff}})Q \quad (\text{III.8a})$$

and

$$h_0 = \frac{1}{\alpha} \frac{d}{dr^*} (rQ) \quad (\text{III.8b})$$

The asymptotic solutions of the above equation for Q as r approaches infinity and $2m$ are given by

$$Q_{\infty} \sim e^{\pm\alpha r} \quad \text{and} \quad Q_{2m} \sim e^{\pm\alpha r^*}.$$

Since we require that for large values of r the perturbation fall off to zero, we choose

$$Q_{\infty} \sim e^{-\alpha r}.$$

But, if Q is taken to be positive, equation (III.8a) shows that $\frac{dQ}{dr^{*2}}$ never becomes negative within the range of r from $2m$ to ∞ and hence the solution that goes to zero at spatial infinity cannot be matched to the one that goes to zero at $r = 2m$, so that asymptotic solution near $r = 2m$ has to be

$$Q_{2m} = Ae^{-\alpha r^*}$$

where A is a constant. Using this solution the radial function h_0 in the neighborhood of $r = 2m$ is readily obtained as

$$h_0 = -2m\alpha Q_{2m}$$

Substituting the above solutions for h_0 and h_1 we find that the perturbations in the Kruskal coordinates near the surface $u = v$ would be (angular dependence has been suppressed)

$$\begin{aligned} h_{03}^k &= 8m^2 A(u^2 - v^2)^{-1} (u+v)e^{-\alpha r^*} e^{\alpha t} \\ &= 8m^2 A(u-v)^{-(2m\alpha+1)} \left(\frac{u+v}{u-v}\right)^{2m\alpha} \\ &= 8m^2 A(u+v)^{2m\alpha} (u-v)^{-(4m\alpha+1)} \end{aligned}$$

In deciding whether the Schwarzschild metric is stable or not, we start with a perturbation which is regular everywhere in space at $t = 0$ and see whether such a perturbation will grow with time. The above perturbation was chosen to be regular at spatial infinity. However at $t = 0$ near the Schwarzschild surface it would have the Kruskal transform (set $v = 0$)

$$h_{03}^k (t = 0) = 8m^2 u^{-(2m\alpha+1)}$$

By choosing u small ($u \rightarrow 0$) this perturbation can be made as large as we wish, i.e. the perturbation diverges as $u \rightarrow 0$, whereas the background metric remains finite. This clearly contradicts the assumption that the perturbation is small compared to the background. Such a perturbation is unacceptable and hence can not exist. Thus perturbations with imaginary k that grow exponentially with time are ruled out.

Next let us consider the solutions corresponding to real frequencies. From equation (III.7a) and the plot of V_{eff} shown in figure 3, we see that the asymptotic solutions near $r = 2m$ are

$$Q_{2m} = A e^{\pm ikr^*}$$

where A is a constant. The two solutions correspond to the outgoing and incoming waves. Consider the outgoing solution

$$Q_{2m} = A r^{+ikr^*}.$$

Then we have

$$h_1 = 2m A \left(1 - \frac{2m}{r}\right)^{-1} e^{ikr^*}$$

and

$$h_0 = -2m A e^{ikr^*},$$

so that

$$\begin{aligned} h_{03}^k &= -8m^2 A (u-v)^{-1} e^{ik(r^*-t)} \\ &= -8m^2 A (u-v)^{-1} (u-v)^{4ikm}. \end{aligned} \quad (\text{III.9})$$

Since we finally take the real part of the perturbation, the function $(u-v)^{4ikm}$ contributes only a rapidly oscillating function near $u = v$. Nevertheless, the singularity due to $(u-v)^{-1}$ appears to be serious. This can be remedied by a gauge transformation:

Make an infinitesimal coordinate transformation

$$x^\mu \rightarrow x^\mu + \xi^\mu$$

so that the perturbations change over to

$$h'_{\mu\nu} = h_{\mu\nu} - (\xi_{\mu;\nu} + \xi_{\nu;\mu}) \quad (\text{III.10})$$

In the present case choose

$$\xi_\mu = (0, 0, 0, \xi_3)$$

with

$$\xi_3 = \frac{2m}{ik} A Q e^{-ikt} \Theta \quad (\text{III.11})$$

where Θ is the angular dependence which we shall suppress whenever it does not enter into the computation. Then,

$$h'_{13} = h_{13} - \left(\xi_{3,1} - \frac{2}{r} \xi_3\right)$$

and

$$h'_{03} = h_{03} - \xi_{3,0}$$

It can be readily shown that (near $r = 2m$)

$$h'_{13} = Ar \left[1 + \frac{4m}{ikr^2} \right] Q e^{-ikt} \quad (\text{III.12})$$

and

$$h'_{03} = 0$$

Thus in the neighborhood of $r = 2m$ we have

$$h^{k'}_{03} = -8m^2 A v e^{-1} \left[1 + \frac{1}{ikm} \right] (u-v)^{4ikm}$$

The analogous expression for the incoming waves are

$$h^k_{03} = 8m^2 A (u+v)^{-1} (u+v)^{-4ikm} \quad (\text{before gauge transformation}) \quad (\text{III.13})$$

and

$$h^{k'}_{03} = 8m^2 A e^{-1} v \left[1 + \frac{1}{ikm} \right] (u+v)^{-4ikm} \quad (\text{after gauge transformation}).$$

Although these perturbations are regular, their derivatives are not and diverge at $u = v$ (outgoing) or at $u = -v$ (incoming). This can be easily remedied by building wave packets out of the monochromatic waves. Observe that asymptotically the solutions go over to the Fourier functions $e^{-ik(r^* \pm t)}$. By superposing these functions in the usual way we can build a pulse that vanishes near the surface $u = v$ or $u = -v$ as fast as we wish. In fact even the gauge transformation above was unnecessary, since the original divergence can also be removed this way. The wave packets generated this way remain regular everywhere in the Kruskal geometry (including the initial moment $t = 0$ or the "line" $v = 0$). These are the stable perturbations and they are physically acceptable.

In the foregoing we have treated the real frequency perturbations from the stand point of the stability analysis. We note however that these correspond to gravitational waves. We have shown that a purely monochromatic gravitational wave produces divergence at $u = v$ (outgoing) or $u = -v$ (incoming). In either case one has to build wave packets, by superposition as above, that

vanish near one of these two sheets. Apart from this, we can not deduce any further boundary conditions from our formalism, and one has to recourse to the physics of the situation for this. For instance Matzner¹⁶ in considering the scattering of scalar waves from the Schwarzschild "singularity" imposes the boundary condition of only ingoing waves at the Schwarzschild surface. This is possible because the effective potential in that problem has a peak at $r = \frac{4}{3} \cdot 2m$ and vanishes exponentially as r^* goes to $-\infty$ so that there is no backscatter for even small negative values of r^* . The situation is exactly the same in case of the gravitational waves. Our V_{eff} has a peak at about $r = 3m$ and goes to zero like $\exp(r^*/2m)$ as r^* tends to $-\infty$. Hence the same boundary condition as in the case of Matzner's calculations could be imposed here too. This boundary condition is assumed by Edelman¹⁷ in calculating the gravitational radiation due to a point mass revolving around a larger spherical mass which produces the Schwarzschild background metric. One wishes to impose this boundary condition to define a problem in which all the radiation is being generated by sources outside $r = 2m$, and none is due to the matter which collapsed a (long) time in the past to produce the Schwarzschild background field.

Case 2. $\ell = 1$

The case for $\ell = 1$ is completely different from that for $\ell > 1$. The perturbation in the Ricci tensor δR_{23} reduces identically to zero, since the angular factor multiplying the radial equation in δR_{23} is given by

$$\left(\cos \theta \frac{d}{d\theta} - \sin \theta \frac{d^2}{d\theta^2}\right) P_\ell(\cos \theta)$$

which vanishes for $\ell = 1$. The equation $\delta R_{13} = 0$ yields the relation between h_0 and h_1 ,

$$h_1 = \frac{i}{k} r^2 \frac{d}{dr} \left(\frac{h_0}{r^2}\right), \quad (\text{III.14})$$

where the time dependence of the perturbations is retained as $\exp(-ikt)$. When the above relation is substituted into δR_{03} , it reduces again to zero giving no new information. Thus the set of field equations gives rise to a single relation between h_0 and h_1 . We now show that this relation enables us to transform away both h_{03} and h_{13} by a gauge transformation that leaves the other components of the perturbation unchanged.

Consider the infinitesimal coordinate transformation,

$$x'^{\alpha} = x^{\alpha} + \xi^{\alpha} \quad (\xi^{\alpha} \ll x^{\alpha}).$$

Then $h_{\mu\nu}$ changes to

$$h'_{\mu\nu} = h_{\mu\nu} - \delta h_{\mu\nu}$$

where

$$\delta h_{\mu\nu} = \xi_{\mu;\nu} + \xi_{\nu;\mu}$$

Choose

$$\xi_{\mu} = (0, 0, 0, \xi_3) \tag{III.15}$$

with

$$\xi_3 = \frac{i}{k} h_0 \exp(-ikt) \sin \theta \frac{\partial}{\partial \theta} P_1(\cos \theta).$$

Then

$$\begin{aligned} \delta h_{03} &= \xi_{0;3} + \xi_{3;0} \\ &= \xi_{3,0} \\ &= h_0 \exp(-ikt) \sin \theta \frac{\partial}{\partial \theta} P_1(\cos \theta) \\ &= h_{03} \end{aligned}$$

so that

$$h'_{03} = 0.$$

Similarly,

$$\begin{aligned} \delta h_{13} &= \xi_{1;3} + \xi_{3;1} \\ &= \xi_{3,1} - 2\Gamma_{13}^3 \xi_3. \end{aligned}$$

where $\Gamma_{\alpha\beta}^{\mu}$ denotes the Christoffel symbol. Substituting for ξ_3 and with $\Gamma_{13}^3 = 1/r$, we obtain

$$\begin{aligned}\delta h_{13} &= \frac{i}{k} \left(\frac{dh_0}{dr} - \frac{2h_0}{r} \right) \exp(-ikt) \sin\theta \frac{\partial}{\partial\theta} P_1(\cos\theta) \\ &= h_{13}\end{aligned}$$

from the equation (III.14).

The other perturbation components are unaltered. For instance,

$$\begin{aligned}\delta h_{23} &= \xi_{2;3} + \xi_{3;2} \\ &= \xi_{3,2} - 2\Gamma_{23}^3 \xi_3 \\ &= \frac{i}{k} h_0 \exp(-ikt) \left[\frac{\partial}{\partial\theta} \sin\theta \frac{\partial P_1}{\partial\theta} - 2\cot\theta \sin\theta \frac{\partial P_1}{\partial\theta} \right] \\ &= 0,\end{aligned}$$

since the angular factor is identically zero. Therefore, the perturbations with $\ell = 1$ can be transformed away irrespective of the nature or value assigned to the frequency k (except $k = 0$ which we will deal with later), a particular case being that with purely imaginary k . This completes the proof of stability for the odd perturbations.

D. The Even Parity Perturbations;

In the beginning of this chapter we wrote down the most general form of the perturbation matrix. For $\ell > 1$ there are seven independent radial functions which in the canonical gauge reduce to only four, namely H_0 , H_2 , H_1 and K . The field equations yield the relation $H_0 = H_2 = H$. This is no longer true for $\ell = 1$. Nevertheless, as can be seen readily from the perturbation matrix, there are only six independent radial functions in the general form when $\ell = 1$. This affords an additional degree of freedom while making the gauge transformation which can be utilised to impose the condition $H_0 = H_2 = H$.

The rest of the computations to obtain the radial equations follow as in the case $\ell > 1$ and all the equations appearing in the Appendix A hold for both $\ell = 1$ and $\ell > 1$. In what follows we prove stability for only $\ell > 1$, since the algebra involved is somewhat tedious. The same method can be adopted for $\ell = 1$ also.

For the sake of simplicity we remove the factor $2m$ from the equations which are rather complicated by defining

$$x = r/2m; \quad x^* = \frac{r^*}{2m} = x + \ell \ln(x-1); \quad \bar{k} = 2mk.$$

Also, let

$$S = H_1/r.$$

The second order differential equation for S is given in the Appendix A. Dropping the bar on \bar{k} [time dependence of the perturbations is $\exp(-ikt)$], the asymptotic forms of this equation as x tends to ∞ and 1 , and the corresponding asymptotic solutions are found to be:

$$\frac{d^2 S_\infty}{dx^2} + k^2 S_\infty = 0; \quad S_\infty \sim e^{\pm ikx} \quad \text{for } x \rightarrow \infty \quad (\text{III.16})$$

$$\frac{d^2 S_1}{dx^{*2}} + 2\frac{dS_1}{dx^*} + (k^2 + 1)S_1 = 0; \quad S_1 \sim e^{(-1 \pm ik)x^*} \quad \text{for } x \rightarrow 1$$

As in the odd case set $k = i\alpha$. Then the asymptotic solutions will be

$$S_\infty \sim e^{\pm \alpha x} \quad \text{and} \quad S_1 \sim e^{(-1 \pm \alpha)x^*}$$

To ensure asymptotic flatness at spatial infinity we choose $S_\infty \sim e^{-2x}$. In case of S_1 the solution $e^{(\alpha-1)x^*}$ goes to zero as x^* approaches $-\infty$ for $\alpha > 1$ (the case $\alpha = 1$ will be discussed separately). We investigate whether the two asymptotic solutions $S_\infty \sim e^{-\alpha x}$ and $S_1 \sim e^{(\alpha-1)x^*}$ can be joined on to each other. If this is possible, the function S should have a stationary point between $x = 1$ and $x = \infty$, i.e. at some point in this range $\frac{dS}{dx^*} = 0$ and $\frac{d^2 S}{dx^{*2}} < 0$

assuming S to be positive in this neighbourhood. We shall now show that such a point does not exist. Setting $\frac{dS}{dx} = 0$, the differential equation becomes:

$$\begin{aligned} \frac{d^2S}{dx^2} = & \left[\alpha^2 - \frac{1}{D(x)} \left\{ 8\alpha^2 + 2\ell(\ell+1)\frac{1}{x^3} + 4(\ell-1)(\ell+2)\frac{1}{x^2} + \frac{12}{x^3} \right\} \left(1 - \frac{3}{2x}\right) \right. \\ & \left. + \frac{2}{x^2} \left(1 - \frac{3}{2x}\right) + \frac{\ell(\ell+1)}{x^2} \left(1 - \frac{1}{x}\right) \right] S. \end{aligned} \quad (\text{III.17})$$

where

$$D(x) = \left(1 - \frac{1}{x}\right)^{-1} \left[\frac{4}{x} \left(1 - \frac{1}{x}\right) + 2(\ell-1)(\ell+2) \left(1 - \frac{1}{x}\right) + 2\alpha^2 x^2 - \frac{1}{2x^2} \right]$$

which is positive for all values of x from 1 to ∞ . Write the above equation as

$$\frac{d^2S}{dx^2} = \frac{N(x)}{D(x)} S \quad (\text{III.18})$$

where

$$\begin{aligned} N(x) = & \alpha^2 D(x) - \left\{ 8\alpha^2 + 2\ell(\ell+1)\frac{1}{x^3} + 4(\ell-1)(\ell+2)\frac{1}{x^2} + \frac{12}{x^3} \right\} \left(1 - \frac{3}{2x}\right) \\ & + \frac{2}{x^2} \left(1 - \frac{3}{2x}\right) D(x) + \frac{\ell(\ell+1)}{x^2} \left(1 - \frac{1}{x}\right) D(x) \end{aligned}$$

Or

$$N(x) = (A) - (B) + (C) + (D)$$

where (A) stands for $\alpha^2 D(x)$, etc. Let us divide the range of x into two domains, $1 < x \leq 3/2$ and $x > 3/2$, and show that $N(x)$ is positive in both of them.

Domain $1 < x \leq 3/2$: The terms $-(B)$ and (D) are positive. The term (C) attains its maximum negative value as x approaches 1. But the sum $(A) + (C)$ tends to $D(x)(\alpha^2 - 1)$ as x approaches 1 and is positive since $\alpha > 1$. Hence $N(x) > 0$ for $1 < x < 3/2$. At $x = 3/2$, we have $(B) = (C) = 0$, terms (A) and (D) are positive, so $N(x)$ is positive.

Domain $x > 3/2$: In this domain negative terms are contributed solely by the term (B) and these are

$$\begin{aligned} (B) = & 8\alpha^2 \left(1 - \frac{3}{2x}\right) + 2\ell(\ell+1)\frac{1}{x^3} \left(1 - \frac{3}{2x}\right) + 4(\ell-1)(\ell+2)\frac{1}{x^2} \left(1 - \frac{3}{2x}\right) \\ & + \frac{12}{x^3} \left(1 - \frac{3}{2x}\right). \end{aligned}$$

$$= (a) + (b) + (c) + (d).$$

Similarly the positive terms are:

$$\begin{aligned} (A) &= \alpha^2 D(x) \\ &= \alpha^2 \left[2(\ell-1)(\ell+2) + \frac{4}{x} + 2\left(\alpha^2 x^2 - \frac{1}{4x^2}\right) \left(1 - \frac{1}{x}\right)^{-1} \right] \\ &= (e) + (f) + (g) \end{aligned}$$

$$\begin{aligned} (C) &= \frac{2}{x^2} (1-3/2x)D(x) \\ &= \frac{2}{x^2} (1-3/2x) \left[2(\ell-1)(\ell+2) + \frac{4}{x} + 2\left(\alpha^2 x^2 - \frac{1}{4x^2}\right) \left(1 - \frac{1}{x}\right)^{-1} \right] \\ &= (h) + (i) + (j) \end{aligned}$$

$$\begin{aligned} (D) &= \ell(\ell+1) \frac{1}{x^2} \left(1 - \frac{1}{x}\right) D(x) \\ &= \frac{\ell(\ell+1)}{x^2} \left(1 - \frac{1}{x}\right) \left[2(\ell-1)(\ell+2) + \frac{4}{x} + 2\left(\alpha^2 x^2 - \frac{1}{4x^2}\right) \left(1 - \frac{1}{x}\right)^{-1} \right] \\ &= (k) + (l) + (m). \end{aligned}$$

To show that the positive terms override negative terms, consider:

$$(e) - (a) = \alpha^2 \left[2(\ell-1)(\ell+2) - 8\left(1 - \frac{3}{2x}\right) \right]$$

Compute this for minimum value of $\ell = 2$:

$$(e) - (a) = \alpha^2 \left[8 - 8\left(1 - \frac{3}{2x}\right) \right] = 8\alpha^2 \left(\frac{3}{2x} \right) > 0.$$

so

$$(e) - (a) > 0 \text{ for all } \ell.$$

$$(l) - (b) = 2\ell \frac{(\ell+1)}{x} \left(1 - \frac{1}{2x}\right) > 0$$

$$(h) - (c) = 0$$

$$(i) + (k) - (d) = \frac{2}{x^2} \left[\ell(\ell^2-1)(\ell+2) \left(1 - \frac{1}{x}\right) - \frac{2}{x} \right] + 6/x^4$$

The expression within the square brackets has its minimum value for lowest ℓ and x , i.e. $\ell = 2$ and $x = 3/2$. For these ℓ and x

$$(i) + (k) - (d) = \frac{2}{(1.5)^2} [8/3 - 4/3] + \frac{6}{(1.5)^4} > 0$$

and hence positive for all other ℓ and x values.

We have accounted for all the negative terms and shown that $N(x)$ remains positive for $x > 3/2$. Hence $N(x)$ is positive throughout the range of x . The second derivative of S , $\frac{d^2S}{dx^{*2}}$ has the same sign as S for all x and therefore S has no stationary point. We conclude that the solution going to zero for large values of x has the asymptotic behaviour $S_1 \sim e^{-(\alpha+1)x^*}$ near the Schwarzschild surface. Next, in order to show that this solution gives rise to divergent perturbations in the Kruskal coordinates, we compute the asymptotic solution of the radial function H near $r = 2m$.

The two radial functions H_1 and H are related to each other by the equation

$$\left[\frac{d^2 H_1}{dx^{*2}} + \frac{d}{dx^*} \left(\frac{H_1}{x^2} \right) + \alpha^2 H_1 \right] - 2\alpha \left[\frac{dH}{dx^*} + \frac{1}{2x^2} H \right] = 0. \quad (\text{III.19})$$

Since

$$S = \frac{H_1}{r} \sim e^{-(\alpha+1)x^*}$$

near $x = 1$, we assume the asymptotic forms

$$H_1 = A e^{-(\alpha+1)x^*} \quad \text{and} \quad H = B e^{-(\alpha+1)x^*}$$

where A and B are constants. Substituting these in equation (III.19) we find

$$B = -A$$

so that $H = -H_1$ near $x = 1$. Then the perturbation in the Kruskal coordinates is given by, for instance (angular dependence suppressed),

$$\begin{aligned} h_{00}^k &= f^2(r) (u^2 - v^2)^{-1} [(u^2 + v^2) H - 2uv H_1] e^{\alpha t} \\ &= f^2(r) (u^2 - v^2)^{-1} [u+v]^2 H e^{\alpha t} \\ &= B f^2(r) (u-v)^{-2(\alpha+1)} \end{aligned} \quad (\text{III.20})$$

At $t = 0$ ($v = 0$), the Kruskal transform will be

$$h_{00}^k = B f^2(r) u^{-2(\alpha+1)}$$

which is divergent as $u \rightarrow 0$. Hence the perturbation is unacceptable.

Case $\alpha = 1$:

In this case the asymptotic forms of the differential equation for S and the corresponding solutions are:

x approaching ∞ :

$$\frac{d^2 S_\infty}{dx^{*2}} - S_\infty = 0; \quad S_\infty \sim e^{\pm x}$$

x approaching 1:

$$\frac{d^2 S_1}{dx^{*2}} + 2 \frac{dS_1}{dx^*} = 0; \quad \text{i.e.} \quad \frac{dS_1}{dx^*} + 2S_1 = C$$

(III.21)

where C is a constant. Hence the asymptotic solutions are

$$S_1 \sim e^{-2x^*} \quad \text{and} \quad S_1 \sim C/2.$$

If $S_\infty \sim e^{-x}$ can be matched on to $S_1 \sim \text{constant}$, there should be a region

where $\frac{dS}{dx^*} < 0$, $\frac{d^2 S}{dx^{*2}} < 0$ for $S > 0$. But, the differential equation for S is given by

$$\begin{aligned} \frac{d^2 S}{dx^{*2}} = & -\frac{1}{D(x)} \left\{ \frac{2}{x^2} D(x) + [(\ell-1)(\ell+2) + 3/x] \frac{4}{x} (1 - 3/2x) \right\} \frac{dS}{dx^*} \\ & + \frac{1}{D(x)} \left\{ D(x) - [8 + 2\ell(\ell+1) \frac{1}{x^3} + 4(\ell-1)(\ell+2) \frac{1}{x^2} + \frac{12}{x^3}] (1-3/2x) \right. \\ & \left. + \frac{2}{x^2} (1 - \frac{3}{2x}) D(x) + \frac{\ell(\ell+1)}{x^2} (1 - \frac{1}{x}) D(x) \right\} S \end{aligned} \quad \text{(III.22)}$$

where

$$D(x) = 2 \left[(\ell-1)(\ell+2) + \frac{2}{x} + x^2 (1 + \frac{1}{x}) (1 + \frac{1}{x^2}) \right].$$

$D(x)$ is positive for all values of x . By an analysis similar to the one performed for $\alpha > 1$, it can be shown that the coefficients of $-\frac{dS}{dx^*}$ and of S are both positive for $1 < x < \infty$. If $S > 0$ and $\frac{dS}{dx^*} < 0$, $\frac{d^2 S}{dx^{*2}}$ is never negative, so that the solution going to zero at infinity does not approach a constant value at the Schwarzschild surface. We have therefore to choose

$$S_1 \sim e^{-2x^*}.$$

Using equation (III.19) H is found to be the negative of H_1 , so that

$$h_{oo}^k = f^2(r) (u+v) (u-v)^{-1} H e^{\alpha t}$$

writing

$$H = B e^{-2x^*}$$

where B is a constant, we obtain

$$h_{oo}^k = B f^2(r) (u-v)^{-4}, \quad (\text{III.24})$$

which diverges as u^{-4} at the initial instant $t = 0$.

Thus we have shown that perturbations with $\ell > 1$ and purely imaginary frequencies are physically unacceptable since they are divergent even at the initial moment. This can be shown to be true for perturbations with $\ell = 1$ by the same method as above. We conclude hence that the Schwarzschild metric is stable against even perturbations as it was against the odd ones. This completes the proof of stability against small oscillations.

E. The Even Perturbations with Real Frequencies:

We have already given the asymptotic solutions near the Schwarzschild surface for real frequencies. The outgoing and incoming waves correspond to solutions of the form $e^{(ik-1)x^*}$ and $e^{-(ik+1)x^*}$ respectively. Also, when we evaluate the asymptotic forms of the radial function H in these two cases, we find $H = -H_1$ for the outgoing waves, and $H = H_1$ for the incoming waves. From this information we readily obtain the Kruskal transform

$$h_{oo}^k = A f^2(r) (u-v)^{-2} (u-v)^{4mik} \quad (\text{outgoing})$$

$$h_{oo}^k = A f^2(r) (u+v)^{-2} (u+v)^{-4mik} \quad (\text{incoming})$$

The singular behaviour of these at $u = v$ or $u = -v$ is exactly similar [but of one higher order since we have the term $(u \pm v)^{-2}$ here] to that for odd parity perturbations. Once again, as in the odd case, wave packets can be built by superposition of solutions with the whole range of real frequencies and the divergence removed.

OTHER BOUNDARY CONDITIONS

We shall now consider topics that are not directly related to the problem of stability. These include stationary or time-independent perturbations and perturbations with complex frequencies. In the first case we shall show that the only nontrivial stationary perturbation that can exist is due to the rotation of the source. The analysis of complex frequencies under suitable boundary conditions will lead to resonance scattering, and related phenomena.

A. Stationary Perturbations

In deriving the field equations the time dependence was assumed to be $\exp(-ikt)$, so that, as they appear in Appendix A, the time derivatives are replaced by a multiplying factor $(-ik)$. If the perturbations are independent of time the corresponding field equations are obtained by setting $k = 0$. In what follows we shall work with these equations and study their solutions.

(1) The odd perturbations

Case (i): $\ell = 1$ (the rotational perturbation):

For $\ell = 1$ and $k = 0$, the perturbations of the Ricci tensor δR_{23} and δR_{13} both reduce identically to zero; in the first instance it is the consequence of the vanishing of the angular factor and in the second it is on account of the condition $k = 0$. The equation $\delta R_{03} = 0$ yields the differential equations

$$\frac{d^2 h_o}{dr^2} = \frac{2}{r} h_o \quad (\text{IV.1})$$

The solution that falls off to zero for large values of r is given by

$$h_o = c/r \quad (\text{IV.2})$$

where c is a constant. Then

$$h_{03} = \frac{c}{r} \sin^2 \theta. \quad (\text{IV.3})$$

which can be clearly identified with the rotational perturbation by comparing it with the weak field approximation¹⁸. Moreover, the solution is acceptable down to the Schwarzschild surface $r = 2m$, since a gauge transformation performed on the angular coordinate ϕ makes the corresponding Kruskal perturbation regular at $u = v$, and leaves the other components of the perturbation unchanged. Make the gauge transformation

$$\phi' = \phi + cat$$

where c and a are constants. Equivalently, we have made a gauge transformation given by the vector

$$\xi_{\mu} = (0, 0, 0, \xi_3)$$

with

$$\xi_3 = r^2 \sin^2 \theta \cdot cat.$$

Then

$$\begin{aligned} h'_{03} &= h_{03} - (\xi_{0;3} + \xi_{3;0}) \\ &= h_{03} - \xi_{3,0} \\ &= c r^2 \sin^2 \theta \left(\frac{1}{r^3} - a \right). \end{aligned}$$

Choose

$$a = \frac{1}{(2m)^3}$$

Dropping the prime on the perturbation,

$$h_{03} = \frac{c \sin^2 \theta}{8m^3} \left(1 - \frac{2m}{r} \right) (r^2 + 2mr + 4m^2)$$

When this is transformed to the Kruskal coordinates, the perturbed Kruskal metric assumes the form,

$$\begin{aligned}
ds^2 = & f^2(r) (du^2 - dv^2) + r^2 (d\theta^2 + \sin^2\theta d\phi^2) \\
& + c \exp(-r/2m) (r^2 + 2mr + 4m^2) \\
& \times \sin^2\theta d\phi (udv - vdu) / mr.
\end{aligned} \tag{IV.4}$$

This is identical with the expression derived by Brill and Cohen¹⁹.

The above gauge transformation does not affect the other components of the perturbation. For instance,

$$\begin{aligned}
h'_{13} &= h_{13} - (\xi_{1;3} + \xi_{3;1}) \\
&= h_{13} - (\xi_{3,1} - \frac{2}{r} \xi_3) \\
&= h_{13}
\end{aligned}$$

Secondly, we observe that h_{13} or h_1 was not determined by the field equations. Whatever value we assign to h_1 , it can be transformed away by choosing the appropriate gauge that does not change the other elements of the perturbation matrix.

Before we pass on to higher ℓ values we wish to point out a curious property of the rotational perturbation. The Schwarzschild surface, as is well known, displays the phenomenon of infinite red shift and at the same time acts as a one-way membrane, since it is a null surface. Does the introduction of the rotational perturbation alter the situation? In Appendix B we have derived the condition under which the "infinite red shift surface", i.e. the surface on which the time-like Killing vector admitted by a stationary metric becomes null, is also a null surface. The Kerr metric has been shown to be an example in which the two properties do not coincide on the same surface. In the present case, however, the Schwarzschild surface remains both the infinite red shift surface and null since:

$$\xi^u \xi_\mu = g_{00} = 0 \quad \text{at } r = 2m$$

where ξ^μ is the time-like Killing vector and the normal to the surface

$$n_\mu = (0, 1, 0, 0)$$

and

$$n^\mu n_\mu = g^{\mu\nu} n_\mu n_\nu = g^{11} = \left(1 - \frac{2m}{r}\right),$$

so that

$$n^\mu n_\mu = 0 \text{ at } r = 2m.$$

Thus the small rotation introduced does not "split" the surface.

Case (ii): $\ell > 1$:

The field equations for $k = 0$ and $\ell > 1$ reduce to

$$h_{\perp} = 0$$

and

$$\frac{d^2 h_o}{dr^{*2}} - \frac{2m}{r^2} \frac{dh_o}{dr^*} - \left[\frac{\ell(\ell+1)}{r^2} - \frac{4m}{r^3} \right] \left(1 - \frac{2m}{r}\right) h_o = 0 \quad (\text{IV.5})$$

For large values of r this equation reads

$$\frac{d^2 h_o}{dr^2} - \frac{\ell(\ell+1)}{r^2} h_o = 0 \quad (\text{IV.6})$$

which has the solutions

$$h_o \sim r^{-\ell} \text{ and } r^{\ell+1}. \quad (\text{IV.7})$$

We choose $h_o \sim r^{-\ell}$ which vanishes for large values of r . Near $r = 2m$ ($r^* \rightarrow -\infty$)

the asymptotic form of equation (IV.5) is

$$\frac{d^2 h_o}{dr^{*2}} - \frac{1}{2m} \frac{dh_o}{dr^*} = 0 \quad (\text{IV.8})$$

which has the solutions

$$h_o \sim e^{r^*/2m} \text{ and } h_o \sim \text{constant} = c$$

We cannot match the solution $e^{r^*/2m}$ which vanishes at $r = 2m$ to the solution

$r^{-\ell}$ which vanishes for large r . If we could, there should be a point between $r = 2m$ and $r = \infty$ where $\frac{dh_0}{dr^*} = 0$ and $\frac{d^2h_0}{dr^{*2}} = 0$ assuming $h_0 = 0$. From equation (IV.5) it is evident that this is impossible for $\ell > 1$. Hence at $r = 2m$ we are left with the solution $h_0 = \text{constant} = c$. The corresponding Kruskal transform will be

$$\begin{aligned} h_{03}^k &= 4m(u^2 - v^2)^{-1} u h_0 \\ &= 4mcu(u^2 - v^2)^{-1} \end{aligned} \quad (\text{IV.9})$$

which diverges both at $u = v$ and $u = -v$. It can be shown that if we try to remedy this by gauge transformation, the divergence will show up in h_{13} and moreover the perturbations produced by the gauge transformation will necessarily be functions of either t or ϕ or both. Hence stationary odd perturbations with $\ell > 1$ do not exist.

(2) The even perturbations

Regge and Wheeler have shown that stationary perturbations of even parity with $\ell = 0$ and $\ell = 1$ represent respectively an infinitesimal addition to the Schwarzschild mass and a small displacement of the centre of attraction.

For $\ell > 1$ the field equations reduce to

$$\begin{aligned} H_0 &= H_2 = H \\ H_1 &\equiv 0 \end{aligned} \quad (\text{IV.10})$$

and

$$\frac{d^2H}{dr^{*2}} + \frac{2}{r} \left(1 - \frac{2m}{r}\right) \frac{dH}{dr^*} - \left[\frac{4m^2}{r^4} + \frac{\ell(\ell+1)}{r^2} \left(1 - \frac{2m}{r}\right) \right] H = 0$$

The asymptotic solutions are:

$$\begin{aligned} r \text{ tending to } \infty : & H \sim r^{-\ell} \text{ and } r^{\ell+1} \\ r \text{ tending to } 2m : & H \sim e^{\pm r^*/2m} \end{aligned} \quad (\text{IV.11})$$

As in the odd case the two solutions going to zero at the two boundaries cannot be matched. If we choose $H \sim r^{-\ell}$ at spatial infinity we will be left with $H \sim e^{-r^*/2m}$ near $r = 2m$ and the corresponding Kruskal transform will be

$$\begin{aligned}
h_{00}^k &= f^2(r) (u^2 - v^2)^{-1} (u^2 + v^2) H \\
&= f^2(r) (u^2 + v^2) (u^2 - v^2)^{-2}
\end{aligned}
\tag{IV.12}$$

This divergence cannot be overcome by gauge transformation and hence stationary perturbations of even parity with $\ell > 1$ do not exist.

We may note here that Doroshkevich et.al.⁶ studied the stationary perturbations on the Schwarzschild metric. They found that the even perturbations diverge near the Schwarzschild surface; however they do not seem to have analysed those perturbations in the Kruskal coordinates. Assuming the angular dependence to be specifically $\sin^2\theta$, they have derived the rotational perturbation (again not analysed in the Kruskal coordinates); higher values of ℓ were not considered.

B. Perturbations with Complex Frequencies:

So far we have studied perturbations with the frequency k taking values that are real, imaginary and finally zero. Let us now make k complex, impose suitable boundary conditions, and determine the physical significance of the perturbations thus obtained. This can be done easily in case of the odd perturbations which, as we have seen, are governed by the wave equation

$$\frac{d^2Q}{dr^{*2}} + (k^2 - V_{\text{eff}})Q = 0$$

where, we recall, r^* ranges from $-\infty$ to $+\infty$ and the potential V_{eff} stays positive everywhere and vanishes at the two boundaries. Let us impose the boundary conditions that the waves be entirely outgoing at $r = \infty$ and purely incoming at the Schwarzschild horizon $r = 2m$. That is, the asymptotic forms of Q are given by

$$Q_{\infty} \sim e^{ikr^*} \quad \text{at } r^* = \infty$$

and

$$Q_{-\infty} \sim e^{-ikr^*} \text{ at } r^* = -\infty.$$

Multiplying the wave equation by Q^* , the complex conjugate of Q , and integrating with respect to r^* from $-\infty$ to $+\infty$ we obtain

$$k^2 \int_{-\infty}^{+\infty} |Q|^2 dr^* + \int_{-\infty}^{+\infty} Q^* \frac{d^2 Q}{dr^{*2}} dr^* - \int_{-\infty}^{+\infty} V_{\text{eff}} |Q|^2 dr^* = 0. \quad (\text{IV.13})$$

After partially integrating the second term and substituting the boundary values for Q and Q^* the above equation reduces to

$$k^2 \int |Q|^2 dr^* + ik (|Q_{\infty}|^2 + |Q_{-\infty}|^2) - \left[\int \left(\left| \frac{dQ}{dr^*} \right|^2 + V_{\text{eff}} |Q|^2 \right) dr^* \right] = 0$$

which is in the form

$$Ak^2 + 2iBk - C = 0$$

where A , B and C are constants that are real and positive. Then

$$k = \frac{-iB \pm (AC - B^2)^{1/2}}{A} \quad (\text{IV.14})$$

This expression shows that $\text{Im } k < 0$. What is the physical significance of this result and how is it related to the boundary conditions we have chosen? This we shall discuss below.

(1) Radiation damping:

The phenomenon of radiation damping is well known in electromagnetic theory²⁰. The acceleration of charged particles in external force fields results in emission of radiation. This radiation carries away energy, momentum and angular momentum thereby influencing the motion of the particles. In many problems the reactive effects of the radiation on the sources is negligible. On the other hand if the energy radiated is comparable to the relevant energy of the radiating system, say the kinetic energy of a charged particle, then the radiative reaction becomes important and leads to radiation damping.

For example, a charged particle of mass m bound by a one-dimensional linear restoring force with force constant $k = m\omega_0^2$ oscillates with constant amplitude with frequency ω_0 in the absence of radiation damping. If now the reactive effects are included, the amplitude progressively decreases, as the energy of motion is converted into radiant energy. The frequency is now complex and if the motion of the charge is described by its coordinate $x(t) = x_0 e^{-i\omega t}$ one readily finds that the imaginary part of ω is negative which is also the case with the frequency of the radiation.

The situation we have is exactly similar to the above. Let us first visualize a source of gravitation, a mass particle circling round a central spherical mass for example, somewhere outside the Schwarzschild radius. The radiation flows into the Schwarzschild horizon as well as into the outer region of space in accordance with our boundary conditions. If the radiated energy is negligible compared to the energy of the particle one can think of the particle as in a stable orbit of constant radius emitting radiation of real frequency. But in reality, as in the case of the charged particle, when the radiative reaction is taken into account the damping effects will enter into the picture and are reflected by the negative imaginary part of the frequency which is now complex. Our solutions, of course, do not allow any particles to be present, since the equations were derived under the assumption that the perturbed space-time was empty. Nevertheless, we can conceive of an initial curvature or a "wiggle" superimposed on the Schwarzschild empty space-time which can act as a source of gravitational radiation. As the wiggle is smoothed out and the energy associated with it is carried away in the form of gravitational radiation, the radiation damping may come into play and make the frequency complex.

(2) Resonance scattering:

In scattering processes, such as between a nucleon and a nucleus, for certain values of the energy of the incident particle the scattering cross section exhibits pronounced maxima. This is the phenomenon of resonance scattering. The problem can be treated using complex energies. It can be shown that this naturally leads to poles in the s-matrix describing the scattering and these poles are of the form

$$\frac{i\Gamma}{E - E_r + i\Gamma/2}$$

where E is the energy of the incident particle and the complex resonant energy is given by $(E_r - i\Gamma/2)$. From the purely outgoing wave condition at infinity one can show that $\Gamma > 0$ or that the imaginary part of the resonant energy is negative²², so that the poles of the s-matrix lie in the lower half plane of the complex energy. The corresponding expression for the scattering cross section will contain a factor

$$\left[\frac{\Gamma^2}{(E - E_r)^2 + \Gamma^2/4} \right]$$

which shows that the cross section reaches a maximum if the pole lies near enough to the real axis and the energy E equals the resonant energy E_r . We shall not pursue the example from nuclear physics further; instead we come back to our problem of gravitational waves and apply the above ideas.

Let us denote the incoming and the scattered waves by h_{in} and h_{sc} . The spatial dependence of these waves at $r = \infty$ is given respectively by e^{-ikr} and e^{+ikr} and the total wave in that region is given by

$$h_t(r) = e^{-ikr} + S(k) e^{+ikr} \quad (\text{IV.15})$$

In the nomenclature of one dimensional scattering problems the coefficient of e^{+ikr} is usually termed as the reflection coefficient; we denote it here

by $S(k)$ since it is analogous to the scattering matrix (or scattering matrix element to be more precise) of the general scattering problem and accordingly continue to call it the scattering matrix. If the scattering matrix $S(k)$ has a pole of the form $\frac{1}{k-k_0}$, where k_0 is complex, and if k_0 lies near the real axis $S(k)$ will be very large when the frequency k coincides with the real part of k_0 . Consequently, the scattering cross section which is proportional to $|S(k)|^2$ will be large and we have a resonance. Next let us relate the phenomenon of resonance to the complex eigenvalues of k . In the beginning of this section we saw that the boundary condition of purely outgoing waves at infinity required k to be complex. Further, it can be shown that this condition also implies poles in S -matrix as envisaged above. In order to see this, we write equation (IV.15) as

$$h_t(r) = S(k) \left[\frac{e^{-ikr}}{S(k)} + e^{ikr} \right]. \quad (\text{IV.16})$$

The function within the parenthesis can be taken as the solution for $h_t(r)$ in the absence of normalization. If this solution has to contain only the outgoing wave e^{ikr} for some value of k , then $S(k)$ will have to be very large for that value of k so that the first term corresponding to the incoming wave vanishes. This shows that $S(k)$ has in fact a pole as we assumed to show resonance in the scattering cross section. To sum up, we imposed the outgoing boundary condition on the gravitational waves and found that this required k to be complex and now we see that this also implies poles in the scattering matrix and the consequent occurrence of resonance.

The condition of purely outgoing waves at infinity at all times does not correspond precisely to any physically realizable situation^{2,3}, since in the remote past there must have been an incoming wave which, after the scattering has

taken place, gives rise to the outgoing wave. A more realistic picture would involve an initial incoming wave packet that is aimed to reach the scattering centre at say $t = 0$ and subsequently we would have an outgoing or scattered wave packet. This model of the scattering process will lead to a statement of causality as shown below, provided the scattering matrix is analytic in the upper half plane of complex k .

A long time after the scattering has taken place, the disturbance (which consists of the scattered wave packet) is simply related to the initial wave packet through the scattering matrix²⁴ and this relation can be expressed formally as

$$h_{sc} = S h_{in} \quad (IV.17)$$

Now an incoming wave packet can be represented by Fourier superposition so as to obtain

$$h_{in}(r,t) = \int_{-\infty}^{+\infty} e^{-ik(r+t)} \tilde{h}(k) dk \quad (IV.18)$$

where $\tilde{h}(k)$ is the Fourier transform of $h_{in}(r,t)$. It is evident from the above equation that

$$h_{in}(r,t) = h_{in}(r+t) = h_{in}(s) \quad (IV.19)$$

where

$$s = r + t.$$

Let us impose the condition

$$h_{in}(r+t) = 0 \quad \text{for } r+t < 0.$$

If the position of the scattering centre is taken as the origin $r = 0$, the above condition means the incoming packet would reach the scattering centre at $t = 0$, in the absence of scattering. Then

$$\tilde{h}(k) = \int_{-\infty}^{+\infty} e^{isk} h_{in}(s) ds = \int_0^{\infty} e^{isk} h_{in}(s) ds$$

since

$$(s) = 0 \quad \text{for } s < 0.$$

The integral on the right will converge for $\text{Im } k > 0$ and hence $\bar{h}(k)$ is analytic in the upper half plane of complex k . Next, from equation (IV.17), we obtain the scattered wave packet as

$$h_{sc}(r,t) = \int_{-\infty}^{+\infty} e^{ik(r-t)} S(k) \bar{h}(k) dk. \quad (\text{IV.20})$$

Now, suppose the scattering matrix is analytic in the upper half plane of complex k . If we convert the integration in equation (IV.20) into a contour integration, the contour can be closed with a large semi-circle in the upper half plane ($\text{Im } k > 0$) provided $r-t > 0$ or $t < r$. The integral reduces to zero in this case since the integrand has no poles in the upper half plane. That is

$$h_{sc}(r,t) = 0 \quad \text{for } t < r \quad (\text{IV.21})$$

The incoming packet is aimed to reach the scatterer ($r=0$) at time $t = 0$. Time taken for a pulse that starts from $r = 0$ at this moment to reach a point at a distance r is $t = r$, since the velocity of propagation is taken as $c = 1$.

The result $h_{sc}(r,t) = 0$ for $t < r$, hence, shows that the scattered pulse could not have started from $r = 0$ before the incoming pulse reached that point. On the other hand: if we closed the contour in the lower half plane ($\text{Im } k < 0$) we require $r - t < 0$ and the poles in $S(k)$ will make the integral non-vanishing, so that,

$$h_{sc}(r,t) \neq 0 \quad \text{for } t > r, \quad (\text{IV.22})$$

as it should be, since for $t > r$ the scattered pulse will have time to reach the point r after the process of scattering. Equation (IV.21) is a statement of causality and we have shown that the analyticity of s -matrix in the upper half plane of complex k implies causality. For the gravitational waves, under conditions of resonance, we showed that the imaginary part of the resonant

frequency was indeed negative [equation (IV.14)], which shows that the S-matrix can be non-analytic only in the lower half plane of complex k , thereby making the S-matrix analytic in the upper half plane. The above statement of causality is hence valid in this case. Moreover, this implies that the background metric is stable. For, if the background were not stable, it could generate a disturbance independent of the incoming wave packet and this would be observed at the point under consideration before the critical time $t = r$, which is not the case here. Thus we have once again an indirect confirmation of the stability of the Schwarzschild metric.

CHAPTER V

THE STABILITY OF THE SCHWARZSCHILD METRIC: RIGOROUS TREATMENT

The treatment of the problem of stability as given in Chapter III was characterized as a "naive" point of view. We must now explain what we mean by such a characterization and state what is lacking in the analysis presented in that chapter. Let us begin with a brief review of what we have accomplished so far in solving the problem of stability.

We set out with a perturbation metric superimposed on the Schwarzschild background metric. Each component of this metric was a product of three factors which were functions of the radial coordinate, the angular coordinates (or simply the coordinate θ , since we specialized to the case of axial symmetry), and time t respectively. Since the background was time independent, the time dependence of the perturbation was written simply as $\exp(-ikt)$ for a particular frequency k . The angular factor was a tensor spherical harmonic of angular momentum ℓ and as these functions form a complete set any arbitrary angular dependence of the perturbation could be obtained by a superposition of these functions. Substituting these perturbations into the Einstein field equations (linearized), differential equations for the radial factors were obtained corresponding to a particular value of ℓ and of k which could then be reduced to a single second order differential equation for one of the perturbation components. When the frequency k was made purely imaginary we found that the solutions of the radial equations were not regular everywhere in space at the initial instant $t = 0$. Hence we concluded no perturbation with imaginary k , which would consequently grow large subsequently, was physically acceptable and decided that the metric was stable. We emphasize what we proved: any single mode corresponding to a particular imaginary value of k could not have existed at $t = 0$. Does this show conclusively that the metric is stable? The answer

is definitely in the negative. The metric is inherently stable only if it is stable against any arbitrary perturbation which is well behaved at $t = 0$. In order to build this perturbation, if we were forced to use radial functions corresponding to the imaginary values of k , then the metric would not be stable as this initial perturbations would progressively grow with time. On the other hand, if only the radial functions corresponding to real frequency modes, oscillatory in time, were needed to represent any initial well behaved perturbation, then, the metric would be stable.

Let us be more specific and express the above ideas in a mathematical form. To begin with, at $t = 0$, we have an arbitrary perturbation which is well behaved everywhere in space. This can be represented as

$$h(r, \theta, t = 0) = \sum_{\ell} R_{\ell}(r) \textcircled{H}$$

where \textcircled{H} is the angular function of angular momentum ℓ . The angular functions, i.e. the tensor spherical harmonics form a complete set, so that the above expansion is possible. The function $R_{\ell}(r)$ corresponding to a particular angular momentum ℓ is itself regular and we seek an expansion for it in the form

$$R_{\ell}(r) = \int R_{\ell,k}(r) \phi_{\ell}(k) dk \quad (V.1)$$

where $R_{\ell,k}(r)$ is the radial function corresponding to the angular momentum ℓ and some value of k , and it is obtained as the solution of the radial differential equation for the perturbation. The function $\phi_{\ell}(k)$ is the analogue of the Fourier transform for $R_{\ell}(r)$. Such a representation is possible only if the functions $R_{\ell,k}(r)$ form a complete set. If the values of k involved are discrete the integral reduces to a summation. Now if this complete set - assuming that we do have a complete set - includes radial functions corresponding to imaginary values of k then the perturbation $h(r, \theta, t)$ will exponentially grow with time and the metric will be unstable. If, on the contrary, the radial

functions corresponding to real values of k form a complete set, we can represent the perturbation entirely by means of these functions whose time dependence is oscillatory and hence the metric will be stable. In other words, in order to complete the proof of stability we must show that (a) the solutions of the differential equation form a complete set, and (b) this set does not include any solution characterized by an imaginary value of k . We now proceed to do this - and thereby make the proof of stability rigorous - in the case of the odd perturbation.

A. The Odd Parity Perturbations:

Once again we recall our wave equation:

$$\frac{d^2 Q}{dr^{*2}} + (k^2 - V_{\text{eff}})Q = 0 \quad (\text{V.2})$$

The coordinate r^* ranges from $-\infty$ to $+\infty$. The potential V_{eff} is positive everywhere and vanishes at $r^* = \pm\infty$. We shall now explore the properties of the operator

$$A = \left(-\frac{d^2}{dr^{*2}} + V_{\text{eff}}\right) \quad (\text{V.3})$$

in three different stages:

(1) First we invoke a theorem cited by Wightman²⁵, which is a special case of a more general theorem due to Carleman²⁶.

Theorem: Let Δ be the Laplacian in n dimensions, $\sum_{j=1}^n \frac{\partial^2}{\partial x_j^2}$ and V be an infinitely differentiable real function on R^n , bounded below. Define $A = -\Delta + V$ on the infinitely differentiable functions of compact support. Then A is essentially self-adjoint.

In our case $n = 1$, and we consider the operator $\left(-\frac{d^2}{dr^{*2}} + V_{\text{eff}}\right)$ in the Hilbert space of all square-integrable functions of r^* . Then by the above theorem, this operator has a self-adjoint extension.

(2) Next we consider the spectral decomposition of a self-adjoint operator

and the completeness of its eigenfunctions following Riesz and Nazy²⁷. In order to make their notation readily understandable we interpose the notation of quantum mechanics. We shall assume, for the sake of convenience, the validity of the spectral decomposition theorem and the completeness of the eigenfunctions which will be stated (in the Riesz-Nazy notation) and made use of later.

Consider, then, a self-adjoint operator A with eigenvalues and eigen-vectors given by λ_i and $|\phi_i\rangle$ respectively. Here i ranges from $-\infty$ to $+\infty$. λ_i may be continuous, discrete or both. We label λ_i such that $\lambda_i < 0$ for $i < 0$ and $\lambda_i > 0$ for $i > 0$. Then the operator A has the spectral decomposition

$$A = \sum_{i=-\infty}^{+\infty} \lambda_i |\phi_i\rangle \langle \phi_i| \quad (V.4)$$

The completeness of the eigen-vectors reads

$$I = \sum_{i=-\infty}^{+\infty} |\phi_i\rangle \langle \phi_i| \quad (V.5)$$

where I is the unit operator. Define the projection operator

$$E_k = \sum_{i < k} |\phi_i\rangle \langle \phi_i| \quad (V.6)$$

Since a state vector $|\psi\rangle$ can be expanded as

$$|\psi\rangle = \sum_{i=-\infty}^{i=+\infty} C_i |\phi_i\rangle, \quad (V.7)$$

where C_i are constants, the projection operator E_k acting on $|\psi\rangle$ projects out the part of $|\psi\rangle$ that contain the eigen vectors $|\phi_i\rangle$, $-\infty < i < k$:

$$E_k |\psi\rangle = \sum_{i < k} C_i |\phi_i\rangle. \quad (V.8)$$

The Riesz-Nazy notation makes use of integrals (similar to Stieltjes integrals) instead of the summations above. Now we are ready to state the spectral decomposition theorem:

Theorem: Every self-adjoint transformation A has the representation

$$A = \int_{-\infty}^{+\infty} \lambda dE_{\lambda} \quad (V.9)$$

where $\{E_{\lambda}\}$ is a spectral family which is uniquely determined by the transformation A.

Here any element E_{λ} of the spectral family is a projection and it possesses the following properties:

- (i) $E_{\lambda} \leq E_{\mu}$ for $\lambda < \mu$. This is the symbolic way of stating $(E_{\lambda}f, f) \leq (E_{\mu}f, f)$ for $\lambda < \mu$, where f is any element of the Hilbert space
- (ii) $E_{\lambda}E_{\mu} = E_{\mu}E_{\lambda} = \begin{cases} E_{\lambda} & \text{for } \lambda < \mu \\ E_{\mu} & \text{for } \lambda > \mu \end{cases}$
- (iii) $E_{\lambda} \rightarrow 0$ for $\lambda \rightarrow -\infty$ and $E_{\lambda} \rightarrow I$ for $\lambda \rightarrow \infty$.

The property (iii) is a statement of completeness of the eigen functions and it reads

$$\int_{-\infty}^{\infty} dE_{\lambda} = I \quad (V.9)$$

where I is the unit operator. These properties of E_{λ} can be easily verified in the quantum mechanical analogue.

Coming back to our original problem, since the operator $A = \left(\frac{-d^2}{dr^*2} + V_{\text{eff}}\right)$ is a self-adjoint operator, we see that its eigen functions form a complete set, according to the above theorem. This completes the first half of our task of making the proof of stability rigorous. Now we have to show that this complete set does not contain any function corresponding to imaginary k i.e. $k^2 < 0$.

(3) We define a positive operator A as one for which $(Af, f) > 0$ where f is any non-zero element of the Hilbert space on which A is defined and (af, f) is the scalar product of Af and f.

The operator $A = \left(-\frac{d^2}{dr^*2} + V_{\text{eff}}\right)$ defined on the infinitely differentiable functions of compact support is a positive operator.

For:

$$\begin{aligned}
 (Af, f) &= - \int_{-\infty}^{+\infty} f \frac{d^2 f}{dr^{*2}} dr^* + \int_{-\infty}^{+\infty} V_{\text{eff}} |f|^2 dr^* \\
 &= \int_{-\infty}^{+\infty} (|\frac{df}{dr^*}|^2 + V_{\text{eff}} |f|^2) dr^* \tag{V.10}
 \end{aligned}$$

where we have integrated the first term by parts and made use of the fact that the function f is zero outside a finite interval. The effective potential V_{eff} , as we have observed several times, is positive vanishing at $r^* = \pm \infty$ and hence $(Af, f) > 0$. For a square integrable function f which is a limit of such differentiable functions of compact support, then the weaker inequality $(Af, f) \geq 0$ persists. The operator A is positive. We now show that the spectrum of a positive self-adjoint operator does not contain negative eigenvalues.

We first give the proof in the notation of quantum mechanics. Define the projection operator

$$P_{n,m} = \sum_{i < -n} |\phi_i\rangle \langle \phi_i| - \sum_{i < -(n+m)} |\phi_i\rangle \langle \phi_i| = E_{-n} - E_{-(n+m)} \tag{V.11}$$

Choose a state-vector $|\psi\rangle$ such that

$$P_{n,m} |\psi\rangle = |\psi\rangle.$$

Then

$$\begin{aligned}
 (\psi, A\psi) &= \langle \psi | A | \psi \rangle \\
 &= \langle \psi | A P_{n,m} | \psi \rangle \\
 &= \sum_{j=-\infty}^{+\infty} \lambda_j \langle \psi | \phi_j \rangle \langle \phi_j | P_{n,m} | \psi \rangle \\
 &= \sum_{k < -n} \sum_{j=-\infty}^{+\infty} \lambda_j \langle \psi | \phi_j \rangle \langle \phi_j | \phi_k \rangle \langle \phi_k | \psi \rangle \\
 &\quad - \sum_{k < -(n+m)} \sum_{j=-\infty}^{+\infty} \lambda_j \langle \psi | \phi_j \rangle \langle \phi_j | \phi_k \rangle \langle \phi_k | \psi \rangle. \tag{V.12}
 \end{aligned}$$

Use the orthonormality of the eigenvectors

$$\langle \phi_i | \phi_k \rangle = \delta_{ik}$$

and carry out the summation over j to obtain

$$\begin{aligned} (\psi, A\psi) &= \sum_{k=-\infty}^{-n} \lambda_k \langle \psi | \phi_k \rangle \langle \phi_k | \psi \rangle - \sum_{k=-\infty}^{-(m+n)} \lambda_k \langle \psi | \phi_k \rangle \langle \phi_k | \psi \rangle \\ &= \sum_{k=-(m+n)}^{-n} \lambda_k \langle \psi | \phi_k \rangle \langle \phi_k | \psi \rangle \end{aligned} \quad (V.13)$$

Now the product $\langle \psi | \phi_k \rangle \langle \phi_k | \psi \rangle = |\langle \psi, \phi_k \rangle|^2$ is positive, whereas λ_k is negative in the range $-(m+n)$ to $-n$. Hence

$$(\psi, A\psi) < 0$$

which contradicts the assumption that A is positive. Therefore negative values of λ are forbidden. The spectrum then consists of only positive values of λ .

We now work out the proof in the Riesz-Nagg formalism. Again define the projection operator

$$P_{n,m} = E_{-n} - E_{-(n+m)} \quad (V.14)$$

and let

$$P_{n,m} f = f,$$

where f is some element of the subspace of Hilbert space onto which $P_{n,m}$ projects,

Then

$$\begin{aligned} (Af, f) &= \int_{-\infty}^{+\infty} \lambda d(E_\lambda f, f) \\ &= \int_{-\infty}^{+\infty} \lambda d(E_\lambda P_{n,m} f, f) \\ &= \int_{-\infty}^{+\infty} \lambda d(E_\lambda E_{-n} f, f) - \int_{-\infty}^{+\infty} \lambda d(E_\lambda E_{-(n+m)} f, f) \end{aligned} \quad (V.15)$$

Consider the first term. From the property (ii) of E_λ , we have

$$E_\lambda E_{-n} = \begin{cases} E_\lambda & \text{for } \lambda \leq -n \\ E_{-n} & \text{for } \lambda > -n. \end{cases}$$

Thus for $\lambda > -n$, $(E_\lambda E_{-n} f, f) = (E_{-n} f, f) = \text{constant}$, so that $d(E_\lambda E_{-n} f, f) = 0$.

Thus the first term reduces to $\int_{-\infty}^{-n} \lambda d(E_\lambda f, f)$ and similarly the second term becomes $\int_{-\infty}^{-(n+m)} \lambda d(E_\lambda f, f)$. Consequently,

$$\begin{aligned} (Af, f) &= \int_{-\infty}^{-n} \lambda d(E_\lambda f, f) - \int_{-\infty}^{-(n+m)} \lambda d(E_\lambda f, f) \\ &= \int_{-(n+m)}^{-n} \lambda d(E_\lambda f, f). \end{aligned} \quad (\text{V.16})$$

Now $(E_\lambda f, f)$ is a positive function which increases with λ , whereas λ itself is negative. Therefore $(Af, f) < 0$ which once again contradicts the fact that A is a positive operator. Negative values of λ are forbidden.

Since $A = \left(-\frac{d^2}{dr^*2} + V_{\text{eff}}\right)$ is a positive self-adjoint operator we can apply the above theorem and conclude that its spectrum does not contain any negative values k^2 i.e, purely imaginary frequencies. The value of $k^2 = 0$ is also excluded, since no eigenfunction exists corresponding to this eigenvalue. We may also observe, that the spectrum is continuous since there is no square integrable eigenfunction of the operator as we saw in Chapter III by study of the solutions of the differential equation. The foregoing shows that solutions of the differential equations for the odd perturbations with real frequencies are sufficient to build any initially well behaved perturbation. This is precisely what we set out to prove and this completes the rigorous stability analysis for odd perturbations.

B. The Even Parity Perturbations

The second order differential equation for one of the components of the even perturbations is of the form (see Appendix A):

$$\frac{d^2 S}{dx^{*2}} + f(x,k) \frac{dS}{dx^*} + [k - g(x,k)] S = 0 \quad (V.17)$$

Here f and g are not only functions of x but also of the frequency k . The theorems that we invoked or proved in case of the odd perturbations cannot be applied to the above equation as it stands. Unfortunately we have not been able to cast this equation or the first order differential equations from which it was derived into an eigenvalue equation so that the formalism we gave in case of the odd perturbations can be extended to the present case. Nevertheless we note below certain features of the even perturbations pertaining to the problem of stability which are comforting if not entirely satisfying.

First of all, on physical grounds we expect the even perturbations to behave similar to the odd one. Both represent disturbances on the same background metric and there is no obvious reason why one type of perturbations should differ radically from the other. Furthermore, there is a striking similarity between the asymptotic behaviour of the two types of perturbations. As we have shown in Chapter III, the imaginary frequency perturbations i.e., the unstable perturbations, that vanish at large values of r diverge, in both cases, at the Schwarzschild horizon (as studied in the Kruskal coordinates) at the initial instant $t = 0$. Hence these modes cannot exist singly. Also we have seen in that chapter, the perturbations corresponding to real frequencies asymptotically coincide with the Fourier functions (apart from a factor e^{-x^*}) near the Schwarzschild surface, again just as in the case of the odd perturbations. These functions form a complete set from which any arbitrary well behaved

perturbation can be built up in that region and such a perturbation will be stable since the time-dependence of each component is purely oscillatory. This fact we have already studied in greater detail in Chapter III. Whether solutions with real frequencies will form a complete set throughout space i.e., at all values of x^* , cannot be answered without a complete study of the differential equations governing the perturbations.

In connection with the problem of stability a curious question arises: is it possible to build a perturbation, well behaved at the initial instant everywhere in space, by superposition of solutions corresponding to imaginary frequencies only? This question is of little importance in the odd case since we proved in the last section that the modes with real frequencies formed a complete set into which any initial perturbations could be decomposed. In the even case, however, since we are not in possession of such knowledge, we cannot ignore the possibility of an initial perturbation being built entirely of imaginary frequency modes. This problem can be studied in regions where x^* attains large positive or negative values (i.e., near $r = \infty$ or $r = 2m$) where the asymptotic form of the solutions are known to be of the form e^{kx^*} . Then the question expressed mathematically becomes: can we represent a function $f(x^*)$ well behaved at large values of $|x^*|$ by superposition of functions e^{kx^*} in the form:

$$f(x^*) = \int_{-\infty}^{+\infty} e^{kx^*} \phi(k) dk. \quad (V.18)$$

In order to answer this question consider the following example.²⁸

The function $e^{-x^4/4}$ (the number 4 is introduced for convenience in future computations) tends to zero for large x and is square integrable (this corresponds to a possible initial perturbation). It can therefore be represented as a Fourier integral

$$e^{-x^4/4} = \int_{-\infty}^{+\infty} e^{ikx} \phi(k) dk, \quad (V.19)$$

where $\phi(k)$ is the Fourier transform of $e^{-x^4/4}$ and is itself square integrable.

Can we extend x to complex values and change x to $-ix$ in the above equation? If so, the left hand side would remain unaltered and e^{ikx} on the right goes over to e^{kx} yielding the type of superposition indicated by equation (V.18):

$$e^{-x^4/4} = \int_{-\infty}^{+\infty} e^{kx} \phi(k) dk. \quad (V.20)$$

Whether this integral converges depends on the behaviour of $\phi(k)$ for large k . We will see that the asymptotic behaviour of $\phi(k)$ will make the equation (V.20) possible for every complex (or real) x . In Appendix C we have evaluated $\phi(k)$ for large values of k from the equation

$$\phi(k) = \int_{-\infty}^{+\infty} e^{-\frac{x^4}{4} + ikx} dx, \quad (V.21)$$

using the saddle point method of integration. The asymptotic form of $\phi(k)$ is:

$$\phi(k) = 2 \left(\frac{2\pi}{3} \right)^{1/2} |k|^{-4/3} \exp\left(-\frac{3}{8} |k|^{4/3}\right) \cos\left(\frac{3\sqrt{3}}{8} |k|^{4/3} + \frac{\pi}{6}\right). \quad (V.22)$$

This provides a damping factor $\exp\left(-\frac{3}{8} |k|^{4/3}\right)$ which prevails over e^{kx} and insures that the integral in equation (V.20) converges for every value of x , and is therefore an analytic function of x which must be therefore the analytic continuation of the function $e^{-x^4/4}$ from equation (V.19). This is precisely the superposition we sought in equation (V.18).

The foregoing discussion shows that there can be initially well behaved perturbations which can be built up out of solutions with imaginary frequencies (we emphasize that this is true for even perturbations only at large values of $|x^*|$ where the solutions have the form e^{kx^*}). However, if we introduce the time dependence e^{kt} above, the time development of the perturbation will be

given by $e^{-(x+t)^4/4}$ which dies down as $t \rightarrow \infty$. The perturbation is not at all unstable. Once again this is true near the boundaries of the Schwarzschild geometry. Whether this is true of the intermediate regions, we cannot answer within the framework of our present formalism.

To sum up, in this chapter, we have fortified the proof of stability for odd perturbations as given in Chapter III and made it rigorous by applying general theorems to the differential operator acting on these perturbations. In case of the even perturbations one can make conjectures based on their asymptotic behaviour. Any further knowledge regarding the stability of the Schwarzschild metric against these perturbations can only come from a more detailed study of the differential equations governing them which has not been possible at present.

REFERENCES AND FOOTNOTES

1. For some recent discussions of gravitational collapse see: Kip Thorne, "Relativistic Stellar Structure and Dynamics", in Les Houches Summer School Proceedings, 1966, Gordon and Breach, London (1967), Chapter 8.
M. M. May and R. H. White, Phys. Rev. 141, 1232, (1966).
2. J. R. Oppenheimer and H. Snyder, Phys. Rev. 56, 455, (1939).
3. G. D. Birkhoff, "Relativity and Modern Physics", Harvard University Press, Cambridge, Mass. (1923).
4. T. Regge and J. A. Wheeler, Phys. Rev., 108, 1963, (1957).
5. M. D. Kruskal, Phys. Rev., 119, 1743, (1960).
6. A. G. Doroshkevich, Ya. B. Zel'dovich, I. D. Novikov, Soviet Physics - JETP, 22, 122 (1966)..
7. Lord Rayleigh, Phil. Mag., 14, 184 (1882).
8. J. Frenkel, J. Phys. (U.S.S.R.), 1, 125 (1939).
9. L. P. Eisenhart, "Riemannian Geometry", Princeton University Press, Princeton (1926), Chapter VI.
10. C. W. Misner and D. H. Sharp, Phys. Rev., 136, B.571 (1964).
11. The results pertaining to the interior of the collapsing matter are obtained by setting $p = 0$ in the analysis of Misner and Sharp.
12. The coordiante r here is not the radial coordinate of the Schwarzschild exterior as in the previous sections. There should be no confusion, since the domains of different coordinates are clearly stated in what follows.
13. D. L. Beckedorff and C. W. Misner, (1962), unpublished.
14. See section 8.3 of Thorne (reference 1).

15. L. D. Landau and E. M. Lifshitz, "Fluid Mechanics", Addison - Wesley Publishing Company, Massachusetts (1959), Chapter VII.
16. R. A. Matzner, Ph. D. Thesis, University of Maryland, Department of Physics and Astronomy (1967).
17. L. A. Edelstein, Ph. D. Thesis, University of Maryland, Department of Physics and Astronomy (1967).
18. L. D. Landau and E. M. Lifshitz, "The Classical Theory of Fields", Addison-Wesley Publishing Company, Massachusetts (1962), Section 103.
19. D. R. Brill and J. M. Cohen, Phys. Rev., 143, 1011 (1966).
20. See for example J. D. Jackson, "Classical Electrodynamics", John Wiley and Sons, New York, Section 17.1 and 17.8.
21. See for example T. Y. Wu and T. Ohmura, "Quantum Theory of Scattering", Prentice-Hall, Inc., New Jersey, Chapter 1, Section A.
22. J. M. Blatt and V. F. Weisskopf, "Theoretical Nuclear Physics", John Wiley and Sons, New York, Chapter VIII, Section 9.
23. For a discussion of the similar situation in case of decaying states in nuclear physics, see reference 22, p.414.
24. See L. S. Rodberg and R. M. Thaler, "Introduction to Quantum Theory of Scattering", Academic Press, New York (1967), Chapter 9, Section I.
25. A. S. Wightman, "Introduction to Some Aspects of the Relativistic Dynamics of Quantized Fields", Lecture notes, French Summer School of Theoretical Physics, Cargese Corsica (1964), p. 118.
26. T. Carleman, Arkiv for Math. Fys., 24, No. 11 (1934).
27. F. Riesz and B. Sz.-Nagy, "Functional Analysis", Frederick Ungar Publishing Co., New York (1965), Section 120.
28. This example was furnished by Professor A. J. Dragt, (Private Communication).

DIFFERENTIAL EQUATIONS FOR PERTURBATIONS ON THE SCHWARZSCHILD METRIC

In this appendix we present the correct equations for the Regge-Wheeler perturbations on the Schwarzschild metric.¹ These equations were first derived by Regge and Wheeler.² Manasse³ pointed out that the equations appearing in the literature contained errors and were inconsistent with the Einstein field equations. Brill and Hartle⁴ rederived the odd parity equations which once again contained some errors as published.

We have obtained the equations for both odd and even parity perturbations and have verified their internal consistency which provides a check on their correctness.

Odd Parity Equations

The notation for the remainder of the paper is the same as that of reference 2. The spherically symmetric line element is

$$ds^2 = - e^{\nu} dt^2 + e^{\lambda} dr^2 + r^2 (d\theta^2 + \sin^2\theta d\phi^2) \quad (\text{A.1})$$

For such a spherically symmetric background, $\delta R_{\mu\nu}$ has the same angular dependence and same number of independent radial factors as the perturbations in equations (12) and (13) of Regge and Wheeler. Hence the components of $\delta R_{\mu\nu}$ that we list in both odd and even parity cases are sufficient to determine all the components. In the Regge-Wheeler canonical gauge, the first order perturbations of the Ricci tensor are:⁵

$$\delta R_{23} = -\frac{1}{2} \left[i k e^{-\nu} h_0 + e^{-\lambda} \left\{ \frac{1}{2} (\nu_r - \lambda_r) h_1 + \frac{dh_1}{dr} \right\} \right] \\ \times \left(\cos\theta \frac{d}{d\theta} - \sin\theta \frac{d^2}{d\theta^2} \right) P_L e^{-ikt} \quad (\text{A.2a})$$

$$\delta R_{13} = \frac{1}{2} \left[i k e^{-\nu} \left(\frac{dh_0}{dr} - 2 \frac{h_0}{r} \right) + \left\{ \frac{L(L+1)}{r^2} - e^{-\nu} k^2 + \frac{e^{-\lambda}}{r} (\lambda_r - \nu_r - \frac{2}{r}) \right\} h_1 \right] \\ \times \sin\theta \frac{dP_L}{d\theta} e^{-ikt} \quad (\text{A.2b})$$

$$\delta R_{03} = - \left[\frac{1}{2} e^{-\lambda} \frac{d^2 h_0}{dr^2} + ik \left\{ \frac{1}{2} e^{-\lambda} \frac{dh_1}{dr} + \frac{e^{-\lambda}}{r} h_1 - \frac{e^{-\lambda}}{4} (v_r + \lambda_r) h_1 \right\} \right. \quad (\text{A.2c}) \\ \left. - \frac{e^{-\lambda}}{4} (v_r + \lambda_r) \frac{dh_0}{dr} + \left(\frac{e^{-\lambda}}{r} v_r - \frac{L(L+1)}{2r^2} \right) h_0 \right] \sin\theta \frac{dP_L}{d\theta} e^{-ikt}$$

where

$$\lambda_r = \frac{d\lambda}{dr}, \quad \lambda_{rr} = \frac{d^2\lambda}{dr^2}, \quad \text{etc.}$$

The angular factors in equations (A.2) are identically zero for $L = 0$ and similarly δR_{23} is identically zero for $L = 1$. For higher values of L , the empty space field equations $\delta R_{\mu\nu} = 0$ imply that the bracketed factors vanish, giving three radial equations. The second order radial equation is a consequence of the other two provided

$$(v - \lambda)_{rr} + \frac{1}{2} (v_r - \lambda_r)^2 - \frac{1}{2} [(v_r)^2 - (\lambda_r)^2] + \frac{1}{r} (v_r - 3\lambda_r) = 0 \quad (\text{A.3})$$

This condition is satisfied by the Schwarzschild metric

$$e^v = e^{-\lambda} = 1 - \frac{2m}{r} \quad (\text{A.4})$$

Eliminate h_0 from the first order equations to obtain

$$\frac{d^2 h_1}{dr^2} + \left[\frac{3}{2} (v_r - \lambda_r) - \frac{2}{r} \right] \frac{dh_1}{dr} + \left[\frac{1}{2} (v - \lambda)_{rr} + \frac{1}{2} (v_r - \lambda_r)^2 \right. \\ \left. - e^\lambda \frac{L(L+1)}{r^2} + k^2 e^{\lambda-v} + \frac{2}{r^2} \right] h_1 = 0 \quad (\text{A.5})$$

Define

$$Q = e^{(v-\lambda)/2} h_1 / r = \left(1 - \frac{2m}{r}\right) h_1 / r$$

and

$$dr^* = e^{(\lambda-v)/2} dr \quad (\text{A.6})$$

and find

$$\frac{d^2 Q}{dr^{*2}} + (k^2 - V_{\text{eff}}) Q = 0 \quad (\text{A.7})$$

where

$$V_{\text{eff}} = \frac{e^v L(L+1)}{r^2} - \frac{3}{r} \frac{d}{dr^*} [e^{(v-\lambda)/2}]$$

or for the Schwarzschild background metric

$$V_{\text{eff}} = \left[\frac{L(L+1)}{r^2} - \frac{6m}{r^3} \right] \left(1 - \frac{2m}{r} \right)$$

Even Parity Equations

In the Regge-Wheeler canonical gauge⁵, the independent first order perturbations of the Ricci tensor are:

$$\delta R_{01} = \left[ik \left\{ \frac{dK}{dr} + \left(\frac{1}{r} - \frac{1}{2} v_r \right) K - \frac{1}{r} H_2 \right\} \right. \quad (\text{A.8})$$

$$\left. + e^{-\lambda} \left\{ \frac{e^{\lambda} L(L+1)}{2r^2} - \frac{1}{2} v_{rr} - \frac{1}{4} (v_r)^2 + \frac{1}{4} v_r \lambda_r - \frac{1}{r} v_r \right\} H_1 \right] P_L e^{-ikt}$$

$$\delta R_{12} = \left[\frac{1}{2} ike^{-\nu} H_1 + \frac{1}{2} \frac{dH_0}{dr} - \frac{1}{2} \frac{dK}{dr} + \left(\frac{1}{4} v_r - \frac{1}{2r} \right) H_0 + \left(\frac{1}{4} v_r + \frac{1}{2r} \right) H_2 \right]$$

$$\times \frac{dP_L}{d\theta} e^{-ikt}$$

$$\delta R_{02} = \left[\frac{1}{2} ik(H_2 + K) + \frac{1}{2} e^{-\lambda} \frac{dH_1}{dr} + \frac{1}{4} (v_r - \lambda_r) e^{-\lambda} H_1 \right] \frac{dP_L}{d\theta} e^{-ikt}$$

$$\delta R_{00} = \left[\frac{1}{2} k^2 (H_2 + 2K) + ike^{-\lambda} \left\{ \left(\frac{1}{2} \lambda_r - \frac{2}{r} \right) H_1 - \frac{dH_1}{dr} \right\} \right.$$

$$\left. - \frac{1}{2} e^{v-\lambda} \frac{d^2 H_0}{dr^2} + e^{v-\lambda} \left\{ \frac{1}{4} \lambda_r - \frac{1}{2} v_r - \frac{1}{r} \right\} \frac{dH_0}{dr} \right.$$

$$\left. - \frac{1}{4} v_r e^{v-\lambda} \frac{dH_2}{dr} + \frac{1}{2} v_r e^{v-\lambda} \frac{dK}{dr} \right.$$

$$\left. + e^{v-\lambda} \left\{ \frac{1}{4} v_r \lambda_r - \frac{1}{2} v_{rr} - \frac{1}{4} (v_r)^2 - \frac{1}{r} v_r + \frac{1}{2r^2} e^{\lambda} L(L+1) \right\} H_0 \right.$$

$$\left. + e^{v-\lambda} \left\{ \frac{1}{4} \lambda_r v_r - \frac{1}{2} v_{rr} - \frac{1}{4} (v_r)^2 - \frac{1}{r} v_r \right\} H_2 \right] P_L e^{-ikt}$$

$$\delta R_{11} = \left[ike^{-\nu} \left(\frac{dH_1}{dr} - \frac{1}{2} \lambda_r H_1 \right) - \frac{1}{2} k^2 e^{\lambda-\nu} H_2 + \frac{1}{2} \frac{d^2 H_0}{dr^2} - \frac{d^2 K}{dr^2} \right.$$

$$\left. + \left(\frac{1}{2} v_r - \frac{1}{4} \lambda_r \right) \frac{dH_0}{dr} + \left(\frac{1}{4} v_r + \frac{1}{r} \right) \frac{dH_2}{dr} \right.$$

$$\left. + \left(\frac{1}{2} \lambda_r - \frac{2}{r} \right) \frac{dK}{dr} + \frac{L(L+1)}{2r^2} e^{\lambda} H_2 \right] P_L e^{-ikt}$$

$$\begin{aligned}
\delta R_{22} = & \left[-\frac{1}{2} k^2 e^{-\nu} r^2 K + ikr e^{-(\lambda + \nu)} H_1 - \frac{1}{2} e^{-\lambda} r^2 \frac{d^2 K}{dr^2} \right. \\
& + \frac{1}{2} r e^{-\lambda} \frac{dH_0}{dr} + \frac{1}{2} r e^{-\lambda} \frac{dH_2}{dr} \\
& + \left\{ \frac{1}{4} r^2 e^{-\lambda} \lambda_r - \frac{1}{4} r^2 e^{-\lambda} \nu_r - 2r e^{-\lambda} \right\} \frac{dK}{dr} \\
& + \left\{ \frac{1}{2} r e^{-\lambda} (\nu_r - \lambda_r) + e^{-\lambda} \right\} H_2 \\
& + \left\{ \frac{1}{2} r e^{-\lambda} (\lambda_r - \nu_r) - e^{-\lambda} + \frac{1}{2} L(L+1) \right\} K \Big] P_L e^{-ikt} \\
& + \frac{1}{2} [H_0 - H_2] \frac{d^2 P_L}{d\theta^2} e^{-ikt}
\end{aligned}$$

The angular factors containing derivatives vanish for $L = 0$; also the two angular factors in the expression for δR_{22} are not independent when $L = 1$. For all higher values of L , the empty space field equations $\delta R_{\mu\nu} = 0$ imply that the bracketed factors vanish and specializing to the Schwarzschild background metric yields the system of radial equations:

$$H_0 = H_2 \equiv H \quad (\text{A.9a})$$

$$\frac{dK}{dr} + \frac{1}{r} (K - H) - \frac{m}{r^2} \left(1 - \frac{2m}{r}\right)^{-1} K - i \frac{L(L+1)}{2kr^2} H_1 = 0 \quad (\text{A.9b})$$

$$\frac{d}{dr} \left[\left(1 - \frac{2m}{r}\right) H_1 \right] + ik (H + K) = 0 \quad (\text{A.9c})$$

$$ikH_1 + \left(1 - \frac{2m}{r}\right) \left(\frac{dH}{dr} - \frac{dK}{dr}\right) + \frac{2m}{r^2} H = 0 \quad (\text{A.9d})$$

$$\begin{aligned}
& \left(1 - \frac{2m}{r}\right)^2 \frac{d^2 H}{dr^2} + \frac{2}{r} \left(1 - \frac{2m}{r}\right) \frac{dH}{dr} - k^2 H - L(L+1) \left(1 - \frac{2m}{r}\right) \frac{H}{r^2} \\
& + 2ikm \frac{H_1}{r^2} + 2ik \left(1 - \frac{2m}{r}\right) \frac{1}{r^2} \frac{d}{dr} (r^2 H_1) - 2k^2 K - 2 \left(1 - \frac{2m}{r}\right) \frac{m}{r^2} \frac{dK}{dr} = 0
\end{aligned} \quad (\text{A.9e})$$

$$\begin{aligned}
& 2ik \left(1 - \frac{2m}{r}\right) \frac{dH_1}{dr} + 2ikm \frac{H_1}{r^2} - k^2 H + \left(1 - \frac{2m}{r}\right)^2 \left[\frac{1}{r^2} \frac{d}{dr} (r^2 \frac{dH}{dr}) \right. \\
& \left. - \frac{2}{r^2} \frac{d}{dr} (r^2 \frac{dK}{dr}) \right] + \left(1 - \frac{2m}{r}\right) \left[\frac{4m}{r^2} \frac{dH}{dr} - \frac{2m}{r^2} \frac{dK}{dr} + L(L+1) \frac{H}{r^2} \right] = 0 \quad (\text{A.9f})
\end{aligned}$$

$$\frac{d}{dr} \left\{ \left(1 - \frac{2m}{r}\right) \left[\frac{d}{dr} (r^2 K) - 2rH \right] \right\} - L(L+1) K + k^2 r^2 \left(1 - \frac{2m}{r}\right)^{-1} K$$

$$- 2ikrH_1 = 0 \quad (\text{A.9g})$$

The three first order equations may be used to derive any of the second order equations, if and only if the following algebraic relationship holds.

$$F(r) \equiv - \left[\frac{6m}{r} + (L-1)(L+2) \right] H + \left[(L-1)(L+2) + \frac{2m}{r} - 2 \left(1 - \frac{2m}{r} \right)^{-1} \left(\frac{m^2}{2} + r^2 k^2 \right) \right] K + \left[2ikr - \frac{iL(L+1)}{k} \frac{m}{r^2} \right] H_1 = 0 \quad (\text{A.10})$$

If F is constructed out of the solutions of the first order equations, (A.9a,b,c,d) it can be shown that

$$\frac{dF}{dr} + \frac{m}{r^2} \left(1 - \frac{2m}{r} \right)^{-1} F = 0 \quad (\text{A.11})$$

Hence, if the boundary conditions are chosen so that F vanishes anywhere, it vanishes everywhere.

Finally, the three first order equations together with (A.10) give a second order equation in a single unknown. Define

$$\begin{aligned} \bar{S} &= \left(1 - \frac{2m}{r} \right) \frac{H_1}{r} \\ \bar{r} &= \frac{r}{2m}, \quad x^* = \frac{r^*}{2m}, \quad \bar{k} = 2mk. \end{aligned}$$

Then

$$\begin{aligned} \frac{d^2 \bar{S}}{dx^*2} + \left[(L-1)(L+2) + 3/x \right] \frac{4}{x} \left(1 - \frac{3}{2x} \right) \frac{1}{D(x)} \frac{d\bar{S}}{dx^*} \\ + \left\{ \bar{k}^2 - \frac{1}{D(x)} \left(1 - \frac{3}{2x} \right) \left[8\bar{k}^2 - 2L(L+1) \frac{1}{x^3} - \frac{4(L-1)(L+2)}{x^2} \left(1 - \frac{1}{x} \right) - \frac{12}{3} \left(1 - \frac{1}{x} \right) \right] - \frac{2}{x^2} \left(1 - \frac{3}{2x} \right) \left(1 - \frac{1}{x} \right) - \frac{L(L+1)}{x^2} \left(1 - \frac{1}{x} \right) \right\} \bar{S} = 0 \end{aligned} \quad (\text{A.12})$$

where

$$D(x) = \frac{4}{x} + 2(L-1)(L+2) - 2 \left(\frac{1}{2} + \bar{k}^2 x^2 \right) \left(\frac{x}{x-1} \right)$$

Note $D(x)$ approaches infinity as r tends to $2m$ or ∞ . Also, any zeroes of $D(x)$ are only apparent singularities, as the numerator can be shown to vanish at these points.

Note: In the main body of the thesis we have used the second order differential equation for $S = \frac{H_1}{r}$ instead of that for $\bar{S} = (1 - \frac{2m}{r}) \frac{H_1}{r}$ as given by equation (A.12). With the quantities x, x^*, \bar{k} and $D(x)$ defined as before, the differential equation for S is:

$$\begin{aligned} & \frac{d^2 S}{dx^{*2}} + \left\{ \frac{2}{x} + \frac{1}{D(x)} [(\ell - 1)(\ell + 2) + \frac{3}{x}] \frac{4}{x} \left(1 - \frac{3}{2x}\right) \right\} \frac{dS}{dx^*} \\ & + \left\{ \bar{k}^2 - \frac{1}{D(x)} \left(1 - \frac{3}{2x}\right) \left[8\bar{k}^2 - \frac{2\ell(\ell+1)}{x^3} - \frac{4(\ell-1)(\ell+2)}{x^2} - \frac{12}{x^3} \right] \right. \\ & \left. - \frac{2}{x^2} \left(1 - \frac{3}{2x}\right) - \frac{\ell(\ell+1)}{x^2} \left(1 - \frac{1}{x}\right) \right\} S = 0 \end{aligned} \quad (A.13)$$

REFERENCES AND FOOTNOTES FOR APPENDIX A

1. The computations were carried out in collaboration with Mr. Lester Edelman.
2. T. Regge and J. A. Wheeler, Phys. Rev., 108, 1963, (1957).
3. F. Manasse, J. Math. Phys., 4, 746, (1963).
4. D. R. Brill and J. B. Hartle, Phys. Rev., 135, B271, (1964).
5. K. Thorne and A. Campolottaro (private communication) have checked equation (A.2) on an IBM-7094 computer using a program of Thorne and Zimmerman and agree with our results.
6. For the background metric of equation (A.1) the Regge-Wheeler perturbations h_{00} and h_{11} defined by Regge and Wheeler for the special case of the Schwarzschild exterior metric would be generalized to:

$$h_{00} = e^{\nu} H_0(r) P_L(\cos\theta) e^{-ikt}$$

and

$$h_{11} = e^{\lambda} H_2(r) P_L(\cos\theta) e^{-ikt}$$

APPENDIX B

GENERALIZATION OF THE "SCHWARZSCHILD SURFACE" TO
ARBITRARY STATIC AND STATIONARY METRICS*

by

C. V. Vishveshwara

Department of Physics and Astronomy
University of Maryland, College Park, Maryland

ABSTRACT

A generalization of the $r = 2m$ "Schwarzschild" surface is defined for static metrics which are not necessarily spherically symmetric. This surface exhibits simultaneously the properties of being a "one-way membrane" for causal propagation and of being a surface of infinite redshift. The necessary and sufficient condition that these two phenomena take place on the same surface in an arbitrary stationary metric is also obtained. The distinctions between the static and stationary cases are shown to be essential by examples from the Kerr metric.

I. INTRODUCTORY REMARKS

The "Schwarzschild surface" at $r = 2m$ in the Schwarzschild exterior metric displays several interesting properties which are well-known. Two of them are: (1) With reference to static sources and observers infinite red shift takes place at the surface, (2) the surface is a null surface, so that it acts locally as a one-way membrane¹ (all 4-velocities in the future light cone cross the surface in the same direction). The question arises whether the two phenomena are interrelated and whether it is possible to characterize, in an arbitrary metric, surfaces exhibiting one or both of the above properties. This question can be answered in case of static and stationary metrics; the time-like Killing vector admitted by these metrics makes it possible to analyze the problem in a completely coordinate independent manner.

In Section II, the well known red shift formula is derived, for the sake of completeness, explicitly in terms of the Killing vector, which shows that infinite red shift results at the surface Σ_0 on which the Killing vector becomes null. It will be proved that, in an arbitrary static metric, Σ_0 is necessarily a null surface which means that Σ_0 is both an infinite red shift surface and a one-way membrane as in the case Schwarzschild exterior metric. Similarly, in the case of stationary metrics, the necessary and sufficient condition that the surface on which the Killing vector becomes null be itself a null surface is obtained. In Section III we study the Kerr metric as a specific example of these considerations. It is seen how the two "Schwarzschild" properties of infinite red shift and of "one-way" causality will typically not coincide, in contrast to the Schwarzschild and other static metrics where they occur at the same surface.

These questions have also been studied independently by Brandon Carter², and it is hoped that the present paper can serve as an elementary, though incomplete, introduction to his more general and broadly based study.

II. GENERALIZED "SCHWARZSCHILD" SURFACES

A static metric admits a time-like Killing vector field ξ^a (Latin indices run from 0 to 3) the trajectories of which form a normal congruence³. Hence, the Killing vector satisfies the Killing equation

$$\xi_{a;b} + \xi_{b;a} = 0 \quad (\text{B.1})$$

and the condition for a normal congruence⁴ $\xi_{[a}\xi_{b;c]} = 0$. From the anti-symmetry of $\xi_{a;b}$ this last equation reduces to

$$\xi_a \xi_{b;c} + \xi_b \xi_{c;a} + \xi_c \xi_{a;b} = 0 \quad . \quad (B.2)$$

We can define "static" observers or sources to be those with four-velocities which satisfy³

$$u^a = (-\xi_b \xi^b)^{-1/2} \xi^a \quad . \quad (B.3)$$

The frequency ν that an observer of 4-velocity u^a assigns to a light ray with geodesic tangent k^a is $\nu = -u^a k_a$ so the general red shift formula is given by

$$\nu_o / \nu_s = (k_a u^a)_o / (k_a u^a)_s \quad (B.4)$$

where the subscripts s and o stand for the source and the observer. For "static" sources and observers equation (B.3) reduces this to

$$\nu_o / \nu_s = (-\xi_a \xi^a)_s^{1/2} / (-\xi_a \xi^a)_o^{1/2} \quad (B.5)$$

where use has been made of the fact that, along a null geodesic, the product $\xi_a k^a$ is a constant⁵.

An analogue of the "Schwarzschild surface" is given by $\Sigma_o : \xi_a \xi^a = 0$, for which equation (B.5) yields infinite red shift. (Since no time-like u^a is actually defined on Σ_o , this is meant as a limit, i.e. near Σ_o red shifts may be arbitrarily large.). This condition is important as we shall see in Section III when we study the Kerr metric.

Next, consider the family of surfaces Σ given by

$$\xi_a \xi^a = \text{constant} \quad . \quad (B.6)$$

In order to be sure that Σ , defined in this way, is a regular 3-dimensional hypersurface in 4-space, we shall assume that the gradient of $\xi_a \xi^a$ does not vanish on Σ . Then the vector

$$n_a = \frac{1}{2} (\xi_b \xi^b)_{;a} = \xi_{b;a} \xi^b \quad (B.7)$$

is non-zero and is normal to Σ . We readily verify that ξ^a lies in Σ since it is orthogonal to n_a (use the antisymmetry of $\xi_{a;b}$):

$$n_a \xi^a = \xi_{b;a} \xi^b \xi^a = 0 .$$

Now compute the length of the normal vector:

$$n_b n^b = (\xi_{a;b} \xi^a) (\xi^{c;b} \xi_c) = (\xi_{a;b} \xi_c) (\xi^{c;b} \xi^a) .$$

By use of equation (B.2) it can be shown that

$$n_b n^b = \frac{1}{2} \xi_a \xi^a (\xi_{b;c} \xi^{b;c}) . \quad (\text{B.8})$$

We see that $n_b n^b$ therefore vanishes when $\xi_a \xi^a$ does, so the surface Σ_0 where $\xi_a \xi^a = 0$ is a null surface.

Now all null surfaces are "one way membranes" for causal effects, but this is usually uninteresting. For example the surface $z = t$ in Minkowski space is null (we have $c = 1$) and "one-way" in the sense that future directed time-like curves can only cross this surface in the direction of decreasing z ; to cross it in the sense of increasing z would mean travelling faster than light. Every null surface such as Σ_0 has local properties similar to this standard example, namely it contains at each point exactly one null direction (which is also the normal to the surface) but no time-like vector. The future null cone therefore lies entirely on one side of the null surface, so that all future directed time-like directions cross the null surface in the same sense. What is remarkable about the null surface Σ_0 where $\xi_a \xi^a = 0$ is that it does not extend to spacial infinity (where $\xi_a \xi^a = -1$), so the light rays (null geodesics) it contains neither come from nor escape to infinity. In fact these light rays "stand still" in the sense that their tangent k^a is parallel to ξ^a , the Killing vector which defines the idea of "static", "at rest", or "time-independent" in this metric. To see this note that since n_a and ξ_a are both null vectors lying in Σ_0 , they must be proportional there with $n_a = f \xi_a$. But then equation (B.7) reads $\xi^a_{;b} \xi^b = -f \xi^a$ which shows that ξ^a is parallel to a geodesic tangent k^a .

The situation in stationary metrics is considerably different from that in static metrics due to the fact that the trajectories of the time-like Killing vector field ξ^a no longer form a normal congruence, but on the other hand contain rotational terms.

As in the case of static metrics, we now define "stationary" observers or sources to be those with four-velocities which satisfy

$$u^a = e^{-\psi} \xi^a, \quad u^a u_a = -1$$

The covariant derivative of the four-velocity has the expansion⁶

$$u_{a;b} = -\dot{u}_a u_b - (-g)^{1/2} \epsilon_{abrs} a^r u^s \quad (\text{B.9})$$

where $\dot{u}_a = u_{a;b} u^b = \psi_{,a}$

and $a^r = \frac{1}{2} (-g)^{-1/2} \epsilon^{rspq} u_s u_{p;q}$.

Here a^r is the rotation vector of the four-velocity u^a . As a result, equation(B.2) is modified into the form

$$\begin{aligned} & \xi_{a;b} \xi_c + \xi_{b;c} \xi_a + \xi_{c;a} \xi_b \\ & = -(-g)^{1/2} a^r \xi^s [\epsilon_{abrs} \xi_c + \epsilon_{bcrs} \xi_a + \epsilon_{cars} \xi_b] \end{aligned} \quad (\text{B.10})$$

Nevertheless, equation (B.5) still holds for the four-velocities u^a which now define "stationary" observers and sources. The surface on which ξ^a becomes null is once again an infinite red shift surface with respect to these sources and observers. On the other hand, a straightforward calculation using equation (B.10) leads to the result:

$$n^b n_b = \frac{1}{2} [\xi_a \xi^a (\xi_{b;c} \xi^{b;c}) - \omega_r \omega^r]$$

where $\omega^r = (-g)^{-1/2} \epsilon^{rspq} \xi_s \xi_{p;q}$ so ω^r is the rotation vector associated with the Killing vector trajectories. Hence we have the theorem that the surface on which the Killing vector becomes null will itself be a null surface if and only if the rotation vector of the Killing vector field also becomes null on it. Only under this condition will the infinite red shift surface act as a one-way membrane also.

We may note in passing that, in both static and stationary metrics, the two vector fields ξ^a and n^a yield a natural generalization of the r-t two-surfaces of the Schwarzschild metric, since the tangent 2-planes they define are surface-forming according to Frobenius' theorem⁷ and $\mathcal{L}_\xi(n^a) = 0$. In fact if we think of $\xi_a \xi^a = -e^{2\psi}$ as defining a generalization of the Newtonian gravitational potential ψ [as is reasonable in view of the red shift formula of equation(B.5)] then n^a is a vector in the direction of the field lines (along the potential gradient), and these r-t two-surfaces are swept out by the field lines (trajectories of n^a) under the time translation generated by ξ^a . The same Newtonian imagery helps again if we ask whether any "radial geodesics" can be found, that is geodesics confined to a ξ^a - n^a two-surface. That the answer is usually "no" one can verify by calculation, or understand by considering that even in Newtonian mechanics particles move along a single "line of force" with their velocity and acceleration parallel only under conditions of exceptional symmetry, as in the case of a particle moving along an axis of symmetry.

III. KERR METRIC⁸

The Kerr metric has the form

$$g_{ab} = \eta_{ab} + 2H k_a k_b \quad (B.11)$$

where η_{ab} is the metric of Minkowski space, k_a a null vector field and H a scalar field. In explicit form, the line element is given by

$$ds^2 = dr^2 + 2a \sin^2\theta dr d\phi + (r^2 + a^2) \sin^2\theta d\phi^2 + \chi d\theta^2 - dt^2 + (2mr/\chi)(dr + a \sin^2\theta d\phi + dt)^2$$

where m and a can respectively be identified with the mass and the angular momentum per unit mass of the source, and where

$$\chi(r, \theta) = r^2 + a^2 \cos^2\theta$$

Since the metric components are independent of the time coordinate t , the time-like Killing vector will be

$$\xi_t^a \equiv (\xi^t, \xi^r, \xi^\theta, \xi^\phi) = (1, 0, 0, 0)$$

(the subscript t has been used to distinguish the time-like Killing vector from the other Killing vectors we shall encounter.) and,

$$(\xi_t^a)^2 = g_{oo} = -(r^2 - 2mr + a^2 \cos^2 \theta) / \chi .$$

Consequently, the Killing vector becomes null on surfaces where

$$r^2 - 2mr + a^2 \cos^2 \theta = 0. \quad (B.12)$$

This equation has the solutions

$$r_o = m + (m^2 - a^2 \cos^2 \theta)^{1/2} , \quad r_i = m - (m^2 - a^2 \cos^2 \theta)^{1/2} .$$

Outside the outer surface r_o we can have stationary sources and observers with four-velocities following the Killing vector trajectories and for these and only these infinite red shift occurs at the surface r_o . On the other hand a surface $f(r, \theta) = \text{constant}$ will be null only if the following equation is satisfied:

$$(r^2 - 2mr + a^2) \left(\frac{\partial f}{\partial r} \right)^2 + \left(\frac{\partial f}{\partial \theta} \right)^2 = 0 . \quad (B.13)$$

The surface given by equation (B.12) does not satisfy this condition and therefore the surface r_o is non-null and does not act as a one-way membrane. Here is an instance of the two phenomena of infinite red shift and one-way membrane not taking place at the same surface. However, as Boyer and Price⁸ have pointed out, we do have stationary null-surfaces given by,

$$r^2 - 2mr + a^2 = 0 \quad (B.14)$$

or

$$r_+ = m + (m^2 - a^2)^{1/2} , \quad r_- = m - (m^2 - a^2)^{1/2} \quad (B.15)$$

which are physically significant for $a^2 \leq m^2$.

The null vector field k^a inherent in the Kerr metric is given by,

$$k^a \equiv (k^t, k^r, k^\theta, k^\phi) = (1, -1, 0, 0) .$$

This shows that the future null cone points inwards at the two null surfaces. Particles and light can only enter but not leave these surfaces. (These null surfaces r_+ and r_- , and the infinite red shift surface $r_0(\theta)$ are sketched in Fig. 1.) Concentrating on the outer surface r_+ , we find that we cannot think of stationary observers along ξ_t on this surface, since the surface r_+ lies within the surface r_0 , the two touching each other at $\theta = 0, \pi$, and ξ_t is space-like in the intermediate region between the two surfaces. Even otherwise, r_+ is not an infinite red shift surface as ξ_t does not become null on it. Nevertheless, we can find a set of "pseudo-stationary" observers and sources for whom infinite red shift still occurs on r_+ . This is done as follows.

In addition to ξ_t , the Kerr metric admits ξ_ϕ the Killing vector associated with rotation about the axis. We form a "mixed Killing vector" ξ_α defined by

$$\xi_\alpha^a = p \sin \alpha \xi_t^a + \cos \alpha \xi_\phi^a = (p \sin \alpha, 0, 0, \cos \alpha)$$

where p has the dimension of length and α is the mixing parameter. We wish to determine α and p for which ξ_α becomes null on the surface r_+ . We compute

$$\begin{aligned} (\xi_\alpha)^2 \chi = & -(r^2 - 2mr + a^2 \cos^2 \theta) p^2 \sin^2 \alpha \\ & + [(r^2 + a^2)(r^2 + a^2 \cos^2 \theta) \sin^2 \theta + 2mr a^2 \sin^4 \theta] \cos^2 \alpha \\ & + 4mr a p \sin^2 \theta \sin \alpha \cos \alpha \end{aligned} \quad (B.16)$$

Substituting $r = r_+ = m + (m^2 - a^2)^{1/2}$, we readily obtain

$$\sin^2 \alpha = [1 + (ap/2mr_+)^2]^{-1} .$$

A choice would be

$$ap = 2mr_+, \quad \sin \alpha = 1/\sqrt{2}, \quad \cos \alpha = -1/\sqrt{2} .$$

With these parameters

$$\xi_\alpha = \frac{1}{\sqrt{2}} \left(\frac{2mr_+}{a} \xi_t - \xi_\phi \right) . \quad (B.17)$$

A second sheet $r = r_\alpha(\theta)$ on which ξ_α becomes null (but which is not a null surface) can be found from the other roots of the equation

$$(\xi_\alpha)^2 \chi = 0$$

where p and α have the above values. It is cumbersome to obtain explicit solutions to this equation in terms of θ . However the solutions for r at $\theta = 0, \pi$, and $\pi/2$ can easily be worked out and provide enough information. At $\theta = 0, \pi$ this equation has the only possible root $r = r_+$ whereas at $\theta = \pi/2$, it admits two acceptable roots,

$$r_1 = r_+ \text{ and } r_2 = \frac{r_+}{2} \left[\left(1 + \frac{8mr_+}{2} \right)^{1/2} - 1 \right].$$

For $m > a$, $r_2 > r_1$ so that the null surface $r = r_+$ lies inside the second sheet and the two touch each other at $\theta = 0, \pi$. ξ_α becomes space-like at infinity and hence is time-like in the region between the above two surfaces. Therefore we can define the "pseudo-stationary" sources and observers in this region with four-velocities along ξ_α . Although these have no global significance, since such observers and sources cannot be found at infinity, it is still worthwhile noting that for these, infinite red shift does occur on the null surface r_+ . This surface rather than the surface r_0 , resembles the Schwarzschild surface in that it is a one-way membrane (it exhibits infinite red shift with respect to the "pseudo-stationary" observers as well). This choice is borne out also by an analysis of null geodesics in the equatorial plane⁸ which shows that light signals can be sent to spatial infinity (from sources moving along time-like curves) from every point in the region between the surfaces r_0 and r_+ , whereas no signal can escape from within the surface r_+ .

ACKNOWLEDGEMENT

I am deeply indebted to Professor C. W. Misner for suggesting the problem and for his constant guidance throughout the work, and to the Physical Review's referee for correcting an error in a previous draft of this article.

REFERENCES AND FOOTNOTES FOR APPENDIX B

1. D. Finkelstein, Phys. Rev. 110, 965 (1958).
2. B. Carter, unpublished preprint, "Horizons, Orthogonal Transitivity, and Convective Circulation in an Isometric Manifold", (1966).
3. J. Ehlers in "Gravitation: An Introduction to Current Research", Ed. Louis Witten (John Wiley and Sons, Inc., New York, 1962).
4. Square brackets denote anti-symmetrization:

$$\xi_{[a}\xi_{b;c]} = \frac{1}{6}[\xi_a\xi_{b;c} + \xi_b\xi_{c;a} + \xi_c\xi_{a;b} - \xi_b\xi_{a;c} - \xi_a\xi_{c;b} - \xi_c\xi_{b;a}]$$

We use a metric with signature - + + + .

5. This is shown by a well known computation

$$(\xi_a k^a)_{;b} k^b = \xi_{a;b} k^a k^b + \xi_a k^a_{;b} k^b = 0$$

using the (Killing) antisymmetry of $\xi_{a;b}$ and the geodesic equation for k^a .

6. G. Salzman and A. H. Taub, Phys. Rev., 95, 1959 (1954).
7. See Theorem 5.1 in S. Sternberg "Lectures on Differential Geometry (Prentice-Hall, Inc., Englewood Cliffs, N. J., 1964) or Theorem 8-4 in L. Auslander and R. E. MacKenzie "Introduction to Differentiable Manifolds" (McGraw-Hill Book Company, Inc., New York, 1963). Sufficient for our purposes here is also a comment on P. 105 in J. A. Schouten "Ricci Calculus" (Springer, Berlin, 1954), Second Edition.
8. Some of the basic equations in this section have been taken from the preprint "Maximal Analytic Extension of the Kerr Metric" by R. H. Boyer and R. W. Lindquist. See also R. H. Boyer and T. G. Price, Proc. Camb. Phil. Soc., 61, 531-534, (1965).

FIGURE CAPTION

Figure 1.

Some surfaces of interest in the Kerr metric. The surfaces r_- and r_+ are null surfaces. The time-like Killing vector ξ_t becomes null on the surface r_0 which gives infinite red shift for stationary sources. The "mixed" Killing vector ξ_α becomes null on r_+ and r_α , the latter surface being non-null. In the hatched region (region I), ξ_t is time-like so this region admits stationary observers and sources, while ξ_t is space-like in regions II and III. The vector ξ_α is space-like outside r_α and time-like in the region between r_+ and r_α : The cross-hatched region enclosed by the surface r_- contains the inner surface r_1 (not shown), on which ξ_t again becomes null, and the singularity $r = 0$. The future light-cone points inwards at r_+ (and at r_-) so that particles and light-rays can only enter, but not leave r_+ (resp. r_-). The diagrams have been drawn: (a) for high values of the parameter a , i.e. for a in the neighbourhood of m : the surface r_α lies within r_0 and there is no common region in which both ξ_t and ξ_α are time-like. When a is equal to m , the surface r_α coincides with r_+ . (b) For low non-zero values of a : surface r_0 lies within the surface r_α and in the region between these two surfaces both ξ_t and ξ_α are time-like. For $a = 0$, the Kerr metric goes over to the Schwarzschild metric, the surface r_0 and r_+ coalesce into the Schwarzschild sphere $r = 2m$, r_- collapses into the origin $r = 0$ and r_α ceases to exist.

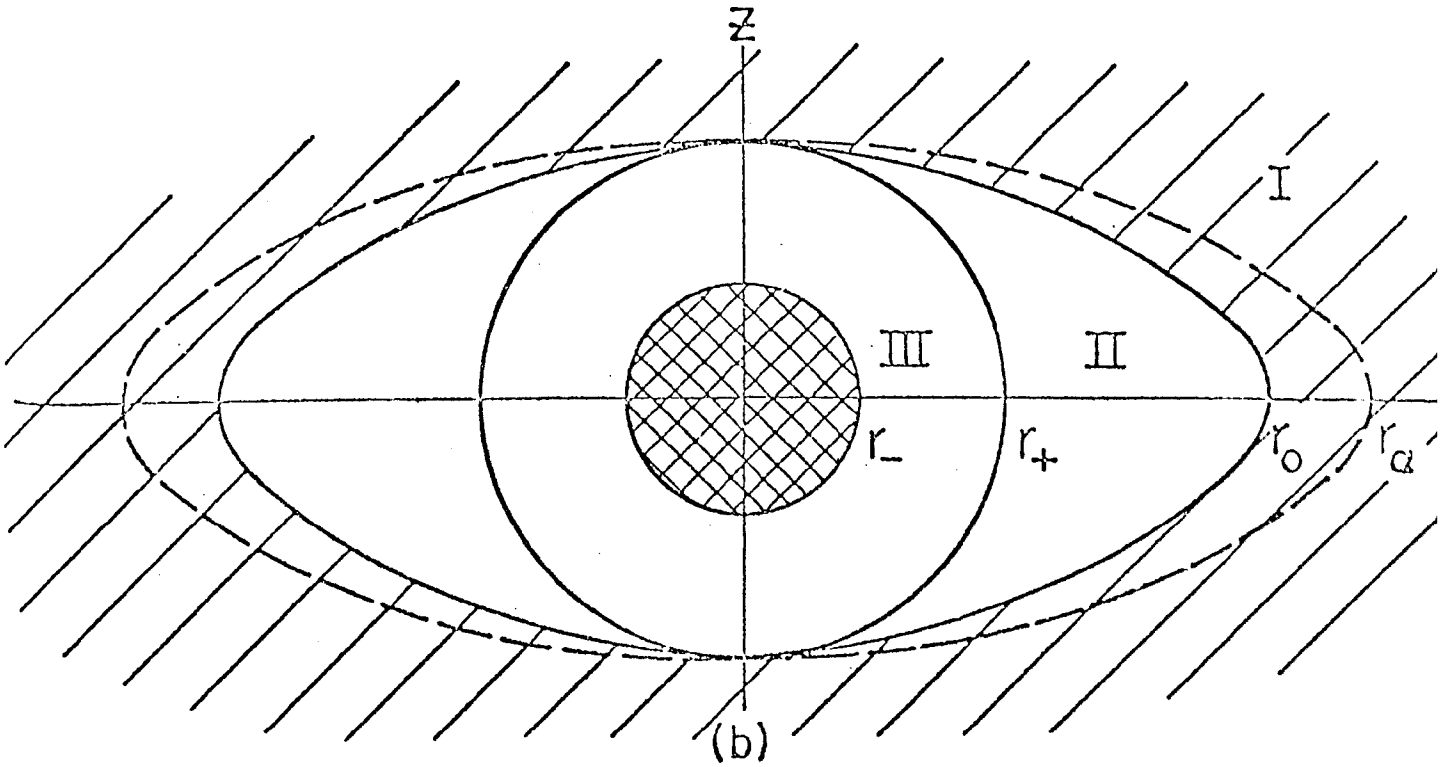
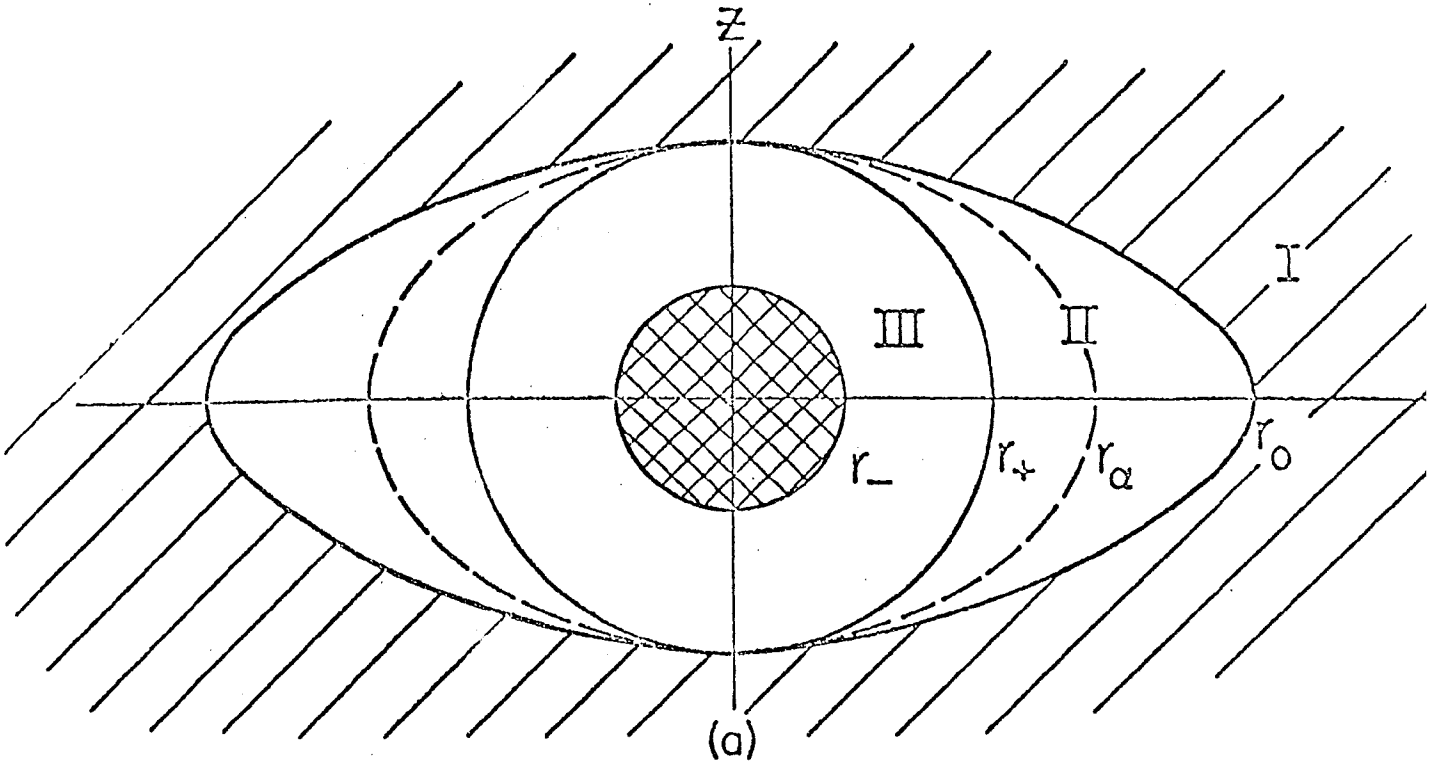

FIG. 1

APPENDIX C

THE ASYMPTOTIC FORM OF THE FUNCTION $\phi(k) = \int_{-\infty}^{+\infty} \exp\left(-\frac{x^4}{4} + ikx\right) dx$
FOR LARGE REAL VALUES OF k

We shall evaluate the function $\phi(k)$ for large values of k by the saddle point method¹. Let us write

$$\phi(k) = \int_{-\infty}^{+\infty} e^{\psi(x)} dx \quad (\text{C.1})$$

where

$$\psi(x) = -\frac{x^4}{4} + ikx, \quad (\text{C.2})$$

or in the complex plane of x ,

$$\psi(z) = -\frac{z^4}{4} + ikz. \quad (\text{C.3})$$

The Saddle Points

The saddle points of $\phi(k)$ are obtained by setting $\psi'(z) = 0$ where the prime denotes differentiation with respect to z (or x when z is real), so that we have

$$\psi'(z) = -z^3 + ik = 0.$$

We have thus three saddle points given by the equation

$$z_s = k^{1/3} (i)^{1/3} \quad (\text{C.4})$$

where k is taken to be positive. These three points are given explicitly as

$$\begin{aligned} z_1 &= k^{1/3} e^{i\pi/6} \\ z_2 &= -k^{1/3} e^{-i\pi/6} \\ z_3 &= k^{1/3} e^{-i\pi/2} \end{aligned} \quad (\text{C.5})$$

The locations of these three points in the complex z plane can be seen in Figure 4. The values of the function $\psi(z)$ and its second derivative $\psi''(z) = -3z^2$ are readily obtained as:

$$\begin{aligned}\psi(z_1) &= \frac{3}{4} ik^{4/3} e^{i\pi/6} = \frac{3}{8} k^{4/3} (-1 + \sqrt{3i}) \\ \psi(z_2) &= -\frac{3}{4} ik^{4/3} e^{-i\pi/6} = \frac{3}{8} k^{4/3} (-1 - \sqrt{3i}) \\ \psi(z_3) &= \frac{3}{4} k^{4/3}\end{aligned}\tag{C.6}$$

and

$$\begin{aligned}\psi''(z_1) &= -3k^{2/3} e^{i\pi/3} \\ \psi''(z_2) &= -3k^{2/3} e^{-i\pi/3} \\ \psi''(z_3) &= -3k^{2/3} e^{-i\pi}\end{aligned}\tag{C.7}$$

The Path of Integration

The original path of integration which was along the real axis is deformed so that it passes through one or more saddle points. Along this path the function should attain its maximum values at the saddle points in order that the contribution to the integral comes almost entirely from this point. In order to select such a path we expand the function $\psi(z)$ in Taylor series up to the term containing the second derivative of $\psi(z)$:

$$\psi(z) = \psi(z_s) + \frac{1}{2} \psi''(z_s) (z - z_s)^2\tag{C.8}$$

Then the direction of the path at the saddle point (the axis of the saddle point) is given by the equation

$$\psi''(z_s) (z - z_s)^2 \text{ real and } \leq 0.$$

In this direction the value of the function decreases on either side of the saddle point and the direction is given by $[-\frac{1}{2} \arg \psi''(z_s)]$ where "arg" stands for the argument. Similarly the function increases on either side of the saddle point along the line

$$\psi''(z_s)(z-z_s)^2 \quad \text{real and } \geq 0$$

which is perpendicular to the axis. Thus the directions of the three axes are given by:

$$\begin{aligned} z_1: & -\pi/6 \quad (-30^\circ) \\ z_2: & +\pi/6 \quad (+30^\circ) \\ z_3: & \pi/2 \quad (90^\circ) \end{aligned} \tag{C.9}$$

These directions are represented by thin arrows in the figure and the perpendicular directions along which the function increases by broad arrows.

Next we must ensure that the path of integration does not cross any region in which the function has a higher value than at the saddle points. This region we already know at the saddle points (broad arrows). Write z as $z = |z|e^{i\theta}$ so that

$$\psi(z) = -\frac{|z|^4}{4} e^{i4\theta} + ik|z|e^{i\theta}.$$

For large values of $|z|$ the first term predominates over the second and has the highest positive real value for $\cos 4\phi = -1$ or $\phi = \frac{\pi}{4} + \frac{n\pi}{2}$. These regions are shown as the cross-hatched parts in the figure. Along the imaginary axis the value of the function decreases away from the saddle point z_3 so that the cross-hatched parts in the upper-half plane are not joined through the imaginary axis. Therefore we conclude that these "ridges" are as shown in the figure (striped regions). The path of integration is forbidden to cross these ridges so that it has to pass through only the two saddle points z_1 and z_2 .

The Integration

The function $\phi(k)$ is given now by

$$\phi(k) = \sum_S e^{\psi(z_S)} \int_p \exp\left[\frac{1}{2} \psi''(z_S) (z-z_S)^2\right] dz, \quad (C.10)$$

where p denotes the path of integration and the summation is taken over the saddle points crossed by the path. Or

$$\phi(k) = e^{\psi(z_1)} \int_p \exp\left[\frac{1}{2} \psi''(z_1) (z-z_1)^2\right] dz + e^{\psi(z_2)} \int_p \exp\left[\frac{1}{2} \psi''(z_2) (z-z_2)^2\right] dz$$

We note $\psi''(z_S) (z-z_S)^2$ is real, but dz is not. However if we make z real and integrate from $-\infty$ to $+\infty$ each term picks up a coefficient $\alpha_S = e^{i\phi_S}$ where ϕ_S is the direction of the axis of the saddle point [see reference (1), section 5.7].

Therefore

$$\begin{aligned} \phi(k) &= e^{3/4 ik} e^{4/3} e^{i\pi/6} e^{i\pi/6} \int_{-\infty}^{+\infty} e^{-3/2 k^{2/3} x^2} dx \\ &\quad + e^{-3/4 ik} e^{4/3} e^{-i\pi/6} e^{-i\pi/6} \int_{-\infty}^{+\infty} e^{-3/2 k^{2/3} x^2} dx \\ &= \frac{2\pi}{3} k^{-4/3} e^{-3/8 k^{4/3}} \left\{ \exp\left[i\left(\frac{3\sqrt{3}}{8} k^{4/3} + \frac{\pi}{6}\right)\right] + \exp\left[-i\left(\frac{3\sqrt{3}}{8} k^{4/3} + \frac{\pi}{6}\right)\right] \right\} \end{aligned}$$

That is,

$$\phi(k) = 2 \frac{2\pi}{3} k^{-4/3} e^{-3/8 k^{4/3}} \cos\left(\frac{3\sqrt{3}}{8} k^{4/3} + \pi/6\right) \quad (C.11)$$

for large values of k .

The above expression was derived for k positive. But the Fourier integral defining $\phi(k)$ shows $\phi(-k) = \overline{\phi(k)}$ where the bar above the function denotes complex conjugation. However, we observe that $\phi(k)$ is real. Hence the above expression is true for large negative values of k also. *if k is replaced by $|k|$.*

REFERENCE FOR APPENDIX C :

1. See, for example, N. G. DeBruin, "Asymptotic Methods in Analysis", North-Holland Publishing Co., Amsterdam (1961), Chapter 5 and references given there.

CAPTIONS FOR FIGURES

Caption for Figure 1: The free-fall collapse of a spherical mass depicted on the Kruskal diagram. The broken line is the time-like world line of the collapsing surface of a star, the collapse having started at some finite time in the past. The picture of a similar collapse starting at an earlier time is obtained by a time translation $t \rightarrow t - T$ in the Schwarzschild coordinate. Correspondingly, a point $P(u, v)$ on the original world-line moves to $P'(u', v')$ along the hyperbola of constant r given by the equation $u^2 - v^2 = \text{constant}$. The solid line, which is obtained by this transformation, represents the surface of the mass that collapsed earlier. The hatched region should be replaced by an appropriate space-time geometry for the interior of this mass distribution; the unhatched region to the right of the solid line is the Schwarzschild exterior surrounding the spherical mass.

Caption for Figure 2: A spherical mass distribution that collapsed into the Schwarzschild horizon in the infinitely remote past. In the time-translation $t \rightarrow t - T$ mentioned in the caption for figure 1, T has been made infinitely large. The surface of the collapsing mass coalesces with the line $u = -v$. The hatched region again should be the interior of the mass and the unhatched region the Schwarzschild exterior surrounding it.

Caption for Figure 3: The effective potential $V_{\text{eff}} = (1 - \frac{2m}{r}) [\frac{\ell(\ell+1)}{r^2} - \frac{6m}{r}]$ for the odd perturbation of angular momentum $\ell = 2$ is plotted against $\frac{r^*}{2m} = \frac{r}{2m} + \ln(\frac{r}{2m} - 1)$. The peak of the potential is at $r \approx 3.3m$.

Caption for Figure 4: The complex z plane discussed in Appendix C. The saddle points are denoted by z_1 , z_2 and z_3 . The path of integration passes through z_1 and z_2 . The hatched regions are the "ridges" on which the function $\phi(k)$ has higher values than at the saddle points.

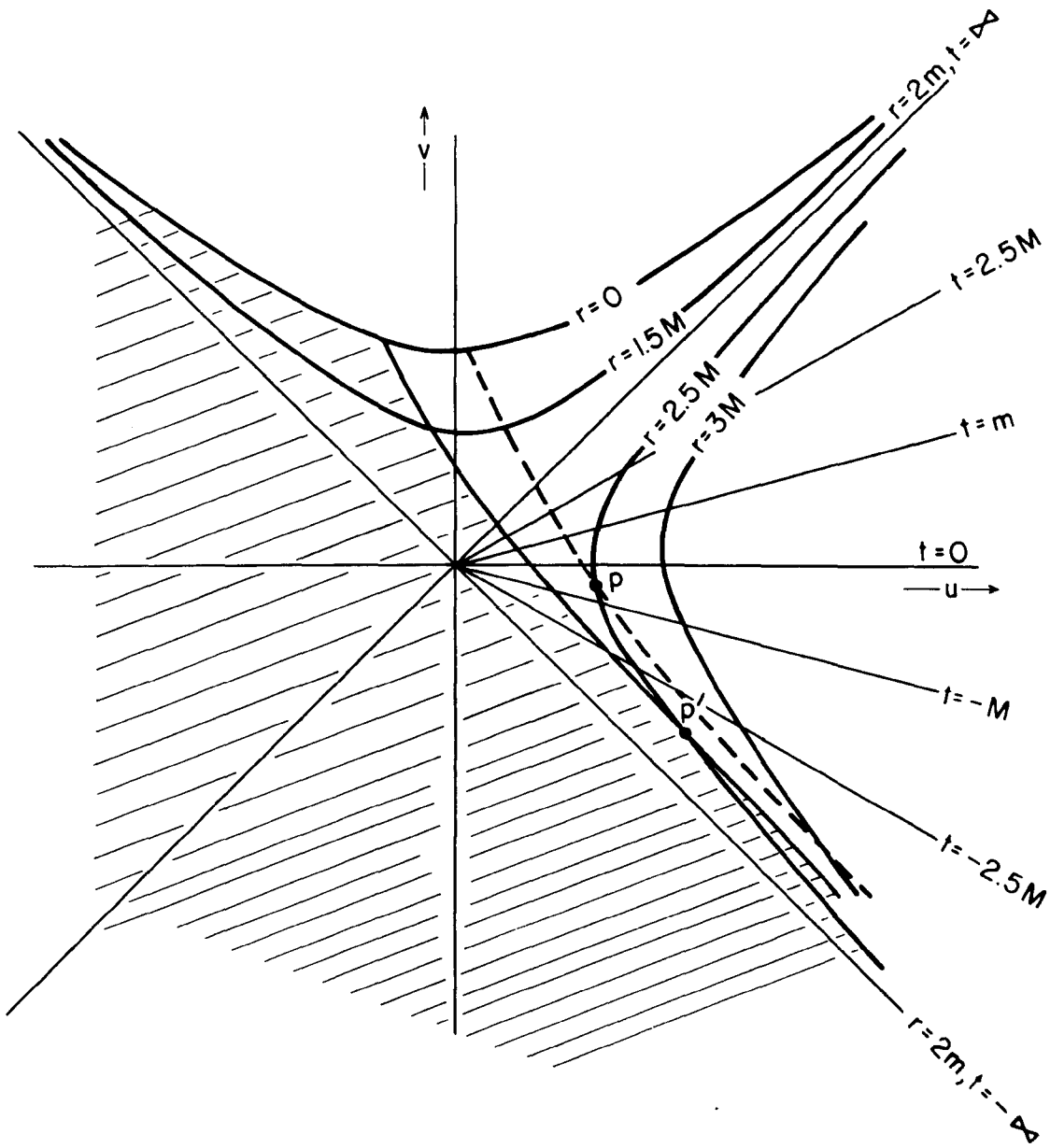

FIGURE 1

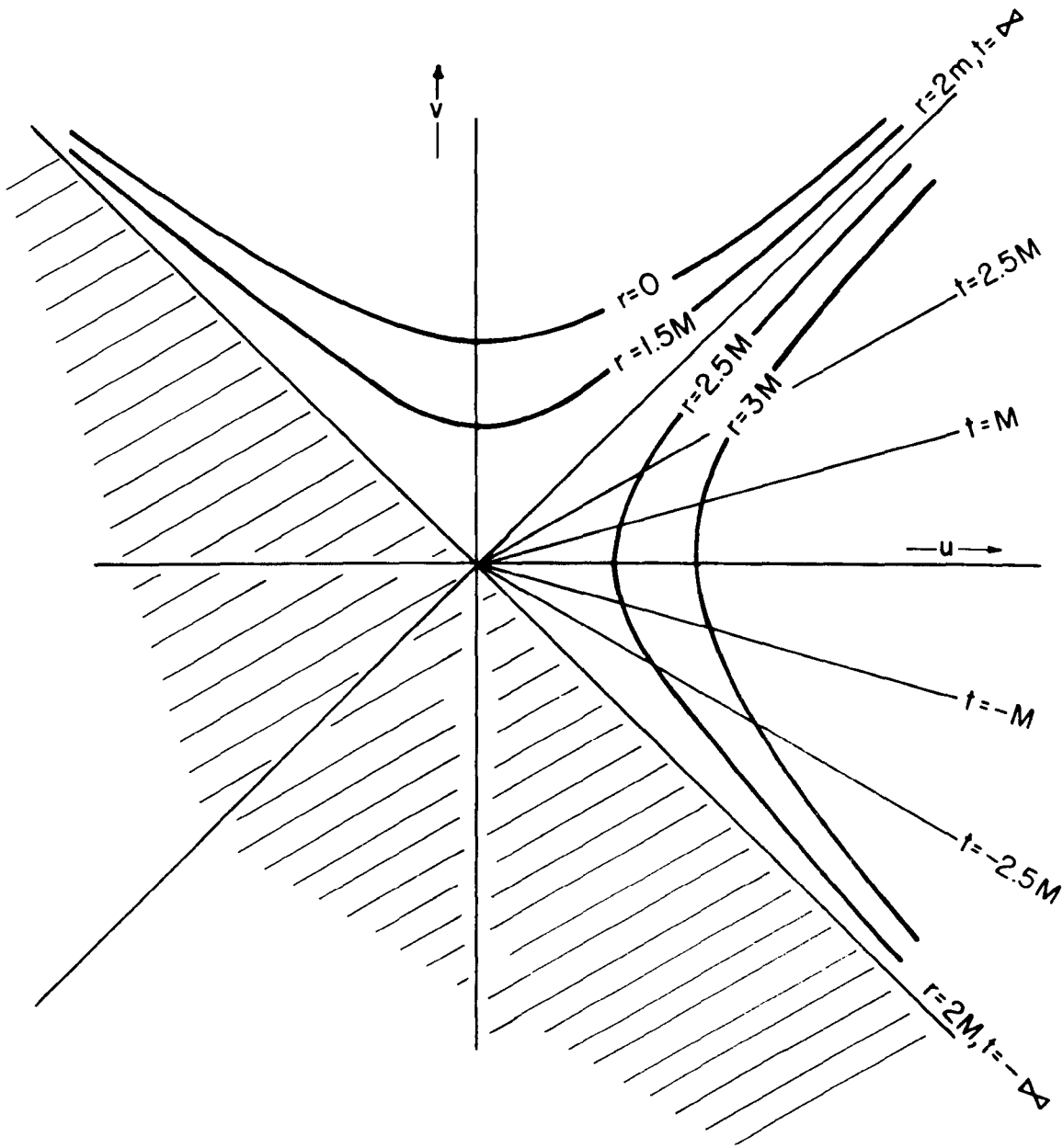

FIGURE 2

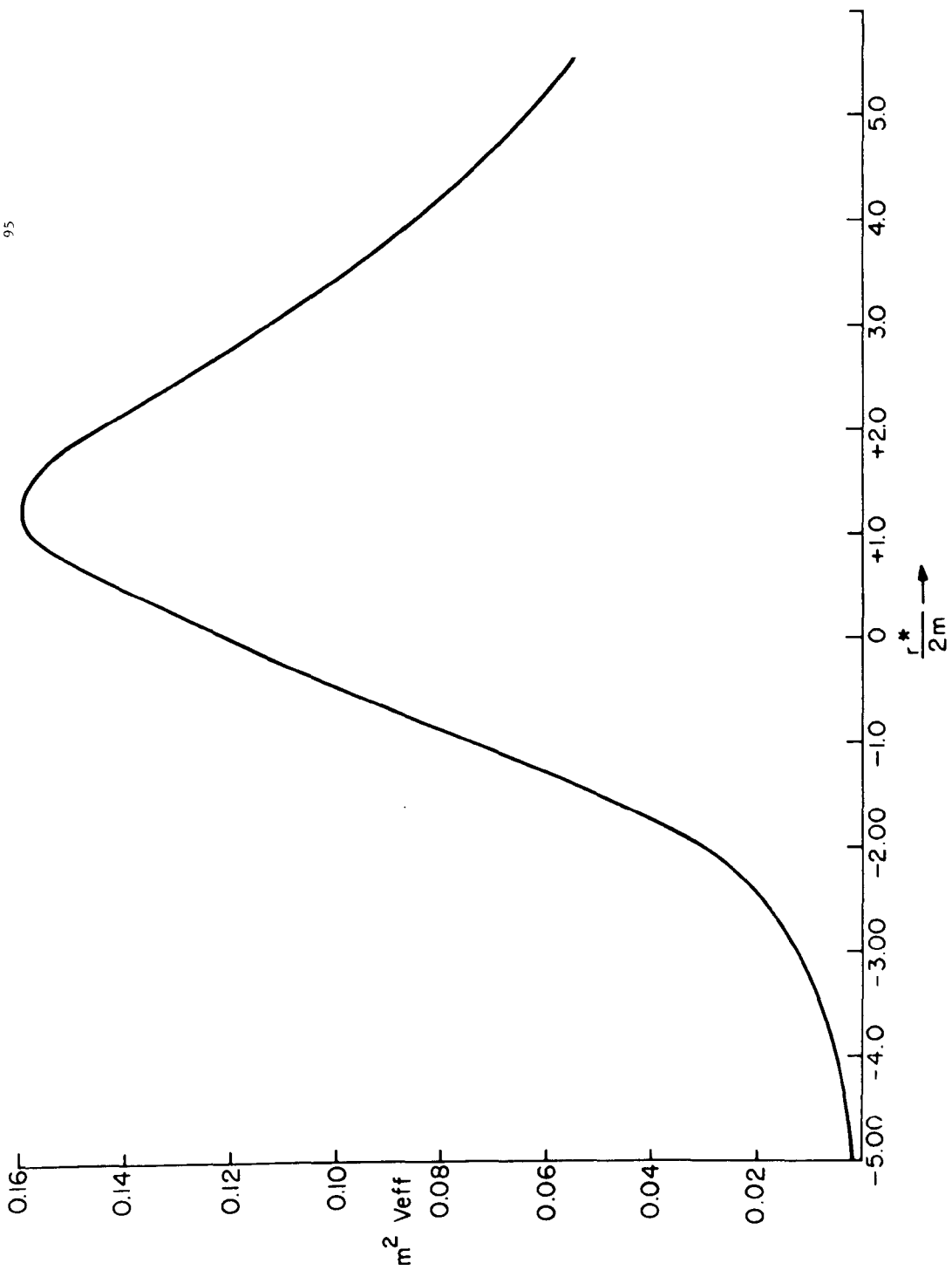

FIGURE 3

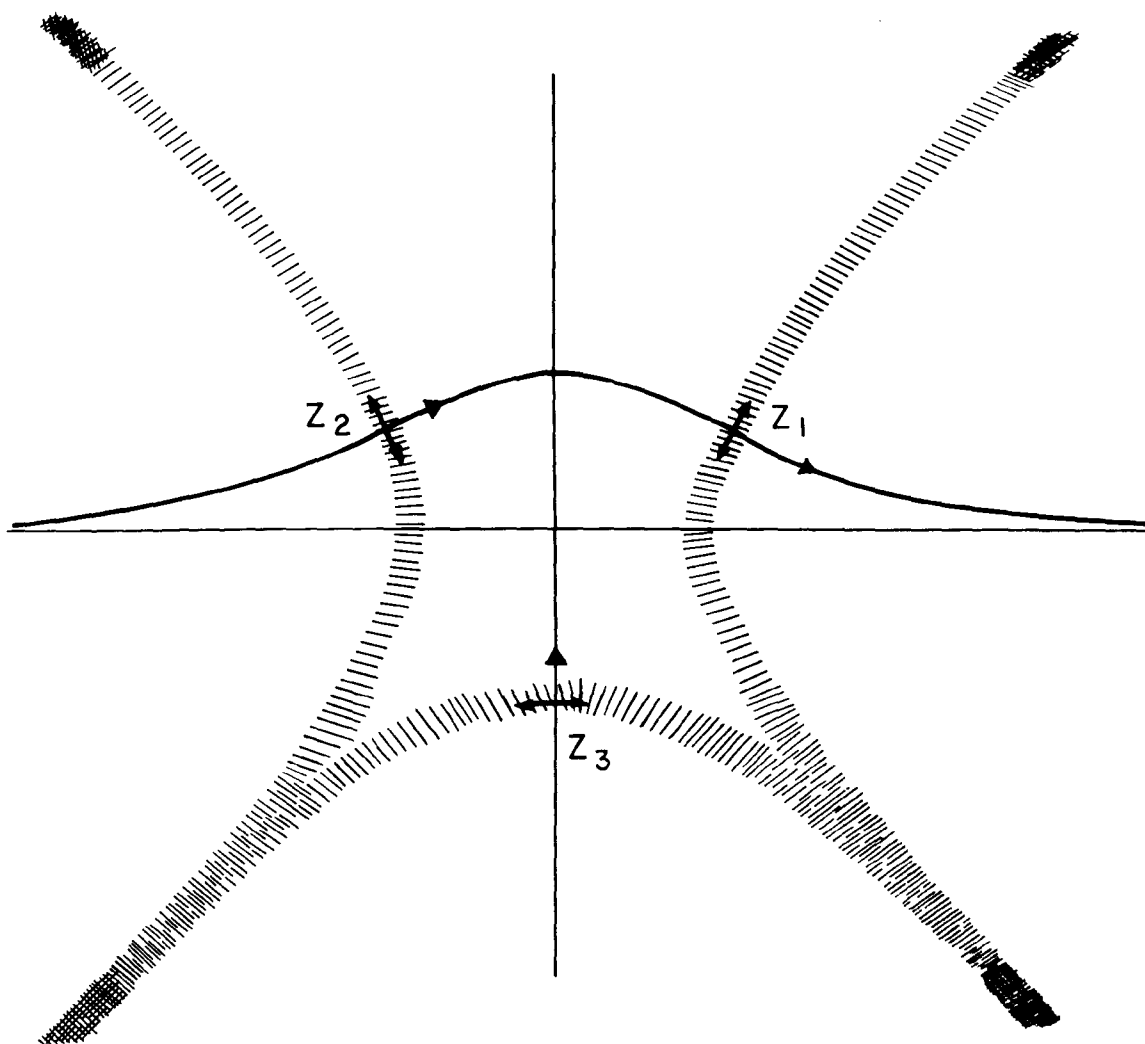

FIGURE 4