

Status of the commissioning of the Virgo interferometer

T. Accadia, F. Acernese, F. Antonucci, P. Astone, G. Ballardin et al.

Citation: *AIP Conf. Proc.* **1446**, 150 (2012); doi: 10.1063/1.4727993

View online: <http://dx.doi.org/10.1063/1.4727993>

View Table of Contents: <http://proceedings.aip.org/dbt/dbt.jsp?KEY=APCPCS&Volume=1446&Issue=1>

Published by the [American Institute of Physics](#).

Additional information on AIP Conf. Proc.

Journal Homepage: <http://proceedings.aip.org/>

Journal Information: http://proceedings.aip.org/about/about_the_proceedings

Top downloads: http://proceedings.aip.org/dbt/most_downloaded.jsp?KEY=APCPCS

Information for Authors: http://proceedings.aip.org/authors/information_for_authors

ADVERTISEMENT

**AIP Advances**

Submit Now

**Explore AIP's new
open-access journal**

- **Article-level metrics
now available**
- **Join the conversation!
Rate & comment on articles**

Status of the Commissioning of the Virgo Interferometer

T. Accadia¹¹, F. Acernese^{5ac}, F. Antonucci^{8a}, P. Astone^{8a}, G. Ballardin²,
F. Barone^{5ac}, M. Barsuglia¹, A. Basti^{7ab}, Th. S. Bauer^{14a}, M. Bebronne¹¹,
M.G. Beker^{14a}, A. Belletoile¹¹, M. Bitossi^{7a}, M. A. Bizouard^{10a},
M. Blom^{14a}, F. Bondu^{15b}, L. Bonelli^{7ab}, R. Bonnand¹³, V. Boschi^{7a},
L. Bosi^{6a}, B. Bouhou¹, S. Braccini^{7a}, C. Bradaschia^{7a}, M. Branchesi^{3ab},
T. Briant¹², A. Brillet^{15a}, V. Brisson^{10a}, T. Bulik^{17cd}, H. J. Bulten^{14ab},
D. Buskulic¹¹, C. Buy¹, G. Cagnoli^{3a}, E. Calloni^{5ab}, B. Canuel²,
F. Carbognani², F. Cavalier^{10a}, R. Cavalieri², G. Cella^{7a}, E. Cesarini^{3b},
O. Chaibi^{15a}, E. Chassande-Mottin¹, A. Chincarini⁴, A. Chiummo²,
F. Cleva^{15a}, E. Coccia^{9ab}, P.-F. Cohadon¹², C. N. Colacino^{7ab}, J. Colas²,
A. Colla^{8ab}, M. Colombini^{8b}, A. Corsi^{8a}, J.-P. Coulon^{15a}, E. Cuoco²,
S. D'Antonio^{9a}, V. Dattilo², M. Davier^{10a}, R. Day², R. De Rosa^{5ab},
G. Debreczeni¹⁸, W. Del Pozzo^{14a}, M. del Prete^{16b}, L. Di Fiore^{5a},
A. Di Lieto^{7ab}, M. Di Paolo Emilio^{9ac}, A. Di Virgilio^{7a}, A. Dietz¹¹,
M. Drago^{16ab}, V. Fafone^{9ab}, I. Ferrante^{7ab}, F. Fidecaro^{7ab}, I. Fiori²,
R. Flaminio¹³, L. A. Forte^{5a}, J.-D. Fournier^{15a}, J. Franc¹³, S. Frasca^{8ab},
F. Frasconi^{7a}, M. Galimberti¹³, L. Gammaitoni^{6ab}, F. Garufi^{5ab},
M. E. Gáspár¹⁸, G. Gemme⁴, E. Genin², A. Gennai^{7a}, A. Giazotto^{7a},
R. Gouaty¹¹, M. Granata¹, C. Greverie^{15a}, G. M. Guidi^{3ab}, J.-F. Hayau^{15b},
A. Heidmann¹², H. Heitmann¹⁵, P. Hello^{10a}, D. Huet², P. Jaranowski^{17e},
I. Kowalska^{17c}, A. Królak^{17af}, N. Leroy^{10a}, N. Letendre¹¹, T. G. F. Li^{14a},
N. Liguori^{16ab}, M. Lorenzini^{3a}, V. Lorette^{10b}, G. Losurdo^{3a},
E. Majorana^{8a}, I. Maksimovic^{10b}, N. Man^{15a}, M. Mantovani^{7ac},
F. Marchesoni^{6a}, F. Marion¹¹, J. Marque², F. Martelli^{3ab}, A. Masserot¹¹,
C. Michel¹³, L. Milano^{5ab}, Y. Minenkov^{9a}, M. Mohan², N. Morgado¹³,
A. Morgia^{9ab}, S. Mosca^{5ab}, V. Moscatelli^{8a}, B. Mours¹¹, F. Nocera²,
G. Pagliaroli^{9ac}, L. Palladino^{9ac}, C. Palomba^{8a}, F. Paoletti^{7a,2}, M. Parisi^{5ab},
A. Pasqualetti², R. Passaquieti^{7ab}, D. Passuello^{7a}, G. Persichetti^{5ab},
M. Pichot^{15a}, F. Piergiovanni^{3ab}, M. Pietka^{17e}, L. Pinard¹³, R. Poggiani^{7ab},
M. Prato⁴, G. A. Prodi^{16ab}, M. Punturo^{6a}, P. Puppò^{8a}, D. S. Rabeling^{14ab},
I. Rácz¹⁸, P. Rapagnani^{8ab}, V. Re^{9ab}, T. Regimbau^{15a}, F. Ricci^{8ab},
F. Robinet^{10a}, A. Rocchi^{9a}, L. Rolland¹¹, R. Romano^{5ac}, D. Rosińska^{17g},
P. Ruggi², B. Sassolas¹³, D. Sentenac², L. Sperandio^{9ab}, R. Sturani^{3ab},
B. Swinkels², M. Tacca², A. Toncelli^{7ab}, M. Tonelli^{7ab}, O. Torre^{7ac},

E. Tournefier¹¹, F. Travasso^{6ab}, G. Vajente^{7ab}, J. F. J. van den Brand^{14ab},
 C. Van Den Broeck^{14a}, S. van der Putten^{14a}, M. Vasuth¹⁸,
 M. Vavoulidis^{10a}, G. Vedovato^{16c}, D. Verkindt¹¹, F. Vetrano^{3ab},
 A. Viceré^{3ab}, J.-Y. Vinet^{15a}, S. Vitale^{14a}, H. Vocca^{6a}, R. L. Ward¹,
 M. Was^{10a}, M. Yvert¹¹

¹*Laboratoire AstroParticule et Cosmologie (APC) Université Paris Diderot, CNRS: IN2P3, CEA: DSM/IRFU, Observatoire de Paris, 10 rue A.Domon et L.Duquet, 75013 Paris - France.*

²*European Gravitational Observatory (EGO), I-56021 Cascina (PI), Italy.*

³*INFN, Sezione di Firenze, I-50019 Sesto Fiorentino^a; Università degli Studi di Urbino 'Carlo Bo', I-61029 Urbino^b, Italy.*

⁴*INFN, Sezione di Genova; I-16146 Genova, Italy.*

⁵*INFN, Sezione di Napoli^a; Università di Napoli 'Federico II'^b Complesso Universitario di Monte S. Angelo, I-80126 Napoli; Università di Salerno, Fisciano, I-84084 Salerno^c, Italy.*

⁶*INFN, Sezione di Perugia^a; Università di Perugia^b, I-06123 Perugia, Italy.*

⁷*INFN, Sezione di Pisa^a; Università di Pisa^b; I-56127 Pisa; Università di Siena, I-53100 Siena^c, Italy.*

⁸*INFN, Sezione di Roma^a; Università 'La Sapienza'^b, I-00185 Roma, Italy.*

⁹*INFN, Sezione di Roma Tor Vergata^a; Università di Roma Tor Vergata, I-00133 Roma^b; Università dell'Aquila, I-67100 L'Aquila^c, Italy.*

¹⁰*LAL, Université Paris-Sud, IN2P3/CNRS, F-91898 Orsay^a; ESPCI, CNRS, F-75005 Paris^b, France.*

¹¹*Laboratoire d'Annecy-le-Vieux de Physique des Particules (LAPP), Université de Savoie, CNRS/IN2P3, F-74941 Annecy-Le-Vieux, France.*

¹²*Laboratoire Kastler Brossel, ENS, CNRS, UPMC, Université Pierre et Marie Curie, 4 Place Jussieu, F-75005 Paris, France.*

¹³*Laboratoire des Matériaux Avancés (LMA), IN2P3/CNRS, F-69622 Villeurbanne, Lyon, France.*

¹⁴*Nikhef, Science Park, Amsterdam, the Netherlands^a; VU University Amsterdam, De Boelelaan 1081, 1081 HV Amsterdam, the Netherlands^b.*

¹⁵*Université Nice-Sophia-Antipolis, CNRS, Observatoire de la Côte d'Azur, F-06304 Nice^a; Institut de Physique de Rennes, CNRS, Université de Rennes 1, 35042 Rennes^b, France.*

¹⁶*INFN, Gruppo Collegato di Trento^a and Università di Trento^b, I-38050 Povo, Trento, Italy; INFN, Sezione di Padova^c and Università di Padova^d, I-35131 Padova, Italy.*

¹⁷*IM-PAN 00-956 Warsaw^a; Warsaw University 00-681 Warsaw^b; Astronomical Observatory Warsaw University 00-478 Warsaw^c; CAMK-PAN 00-716 Warsaw^d; Białystok University 15-424 Białystok^e; IPJ 05-400 Świerk-Otwock^f; Institute of Astronomy 65-265 Zielona Góra^g, Poland.*

¹⁸*RMKI, H-1121 Budapest, Konkoly Thege Miklós út 29-33, Hungary.*

Abstract. Long baseline optical interferometry is a promising technique for the detection of gravitational waves [1], [2], [3], [4]. The French-Italian detector Virgo is a Michelson interferometer with 3 km arms, equipped with high storage time Fabry-Perot cavities. In this kind of detectors, the passage of gravitational waves would be sensed as a differential length variation of the arms. After the end of the second Virgo Science Run, lasting from July 2009 to the beginning of January 2010, some important upgrades have been carried out; in particular, the mirrors of the Fabry-Perot cavities, which act as test masses of the detector, have been replaced by new ones with a higher reflectivity, which should increase by three times the finesse of the cavities; moreover the mirrors are now suspended by silica fibers in a monolithic assembly expected to significantly lower the thermal noise. Finally, the digital signal processing electronics and the global control system have been largely improved. We will present the status of the commissioning of the Virgo interferometer.

Keywords: Gravitational Waves, Interferometry

PACS: 04.80.Nn, 95.75.Mn

INTRODUCTION

Virgo [1] is the Italian-French large-scale, Earth based interferometer committed to the detection of gravitational waves (GW). It is located at the site of the European Gravitational Observatory (EGO) in Cascina, near Pisa. A long period involved in the construction and in the commissioning finally resulted in Science Runs, in which scientific data have been acquired non-stop in correspondence with the two American interferometers Ligo [2]. In particular, up to now, three Virgo Science Runs (VSR) have been performed: VSR1 from May till October 2007, VSR2 from July 2009 till January 2010 and VSR3 from August to October 2010. After the end of VSR2, some upgrades have been carried out on the interferometer in order to improve the sensitivity and the maximum distance from which a gravitational signal can be detected.

After VSR2, a long period was spent in order to replace critical mirrors of the interferometer: the new ones are characterized by a higher reflectivity and are suspended by silica fibers in a monolithic assembly [5]. This configuration is expected to increase the finesse of the interferometer cavities and to significantly reduce the thermal noise. Also some important electronic devices have been improved during the same shut down. At the beginning, the time was spent to recover the correct working of the interferometer in order to be ready for VSR3. After the end of VSR3, the work has been addressed to the study of the different sources of noise in order to cure them and to improve the interferometer sensitivity. After a short description of the Virgo interferometer, this report will focus on the main performed activities.

VIRGO INTERFEROMETER

The differential nature of the effect of a gravitational wave on a set of test masses makes optical interferometers very efficient detection instruments, since they are extremely sensitive to changes in the relative length of the two orthogonal arms [6]. Virgo is a power-recycling Michelson interferometer, characterized by 3 km Fabry-Perot cavities in the long arms. It is made by suspended mirrors, illuminated by a monochromatic laser source. Suspended mirrors behave as free masses, forming a free falling reference system. The Michelson interferometer is aligned in the so-called dark fringe: the recombination of the fields at the anti-symmetric port is destructive. The passage of a gravitational wave induces a differential phase shift in the two arms; thus the interference is no more destructive and a signal can be detected. In order to increase the power circulating inside the interferometer, the power recycling technique is adopted. When the interferometer is tuned at the dark fringe, all the incoming power is reflected back to the laser. Therefore, introducing a mirror between the laser and the beam splitter reflecting back this light can strongly enhance the power circulating inside the interferometer. Virgo optical lay-out is shown in figure 1. The two arm cavities are called North and West, and the mirrors that compose each cavity are called (North or West) input (NI, WI) and end (NE, WE) mirrors. The first mirror encountered by the input beam, before the beam splitter (BS), is the power recycling (PR) mirror. In the interferometer there are two other auxiliary cavities: the Input Mode Cleaner (IMC) and the Output Mode Cleaner (OMC) that have the function to clean the beam from higher order modes, in

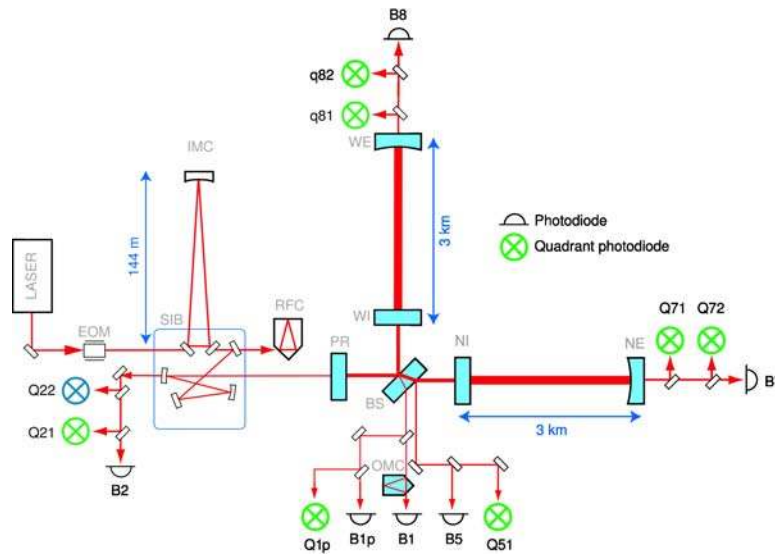

FIGURE 1. Virgo optical scheme.

order to transmit toward the interferometer (IMC) and as output of the interferometer (OMC) only the fundamental Gaussian mode. The main output beams of the interferometer are: the dark fringe (B1), the beam reflected back by the PR mirror (B2), the beam from the secondary anti-reflection-coated surface of the BS (B5), the beam transmitted through the North cavity (B7) and the beam transmitted through the West cavity (B8).

All the Virgo interferometer, except the laser and the photodiodes is under vacuum in order to preserve all the optical components and to limit intensity and phase variations due to the refractive index fluctuations. One key feature of Virgo is the use of high-performance passive seismic isolation systems, called super-attenuators, which combine several mechanical oscillators into a system capable of filtering out seismic noise at frequencies above 4 Hz, in all degrees of freedom [7], [8]. The mirrors are suspended to a chain of seven pendulum. The two lower stages of the suspension are quite different from the others. Indeed, the mirror is surrounded by a metallic reference mass, which is used as a reaction mass to apply forces to the mirror using four coil-magnets pairs on the back side of the mirror. Both the mirror and the reference mass are separately suspended to the marionette by four wires each, as shown in figure 2. Thus, it is possible to act on the mirror also steering the marionette. To this purpose, there are four magnets attached to the marionette itself and four coils attached to pillars coming from the last vertical filter of the chain. The optical and mechanical elements of the interferometer are subject to automatic control, both for the longitudinal degrees of freedom (locking) [9] [10] and the angular ones (alignment) [11] [12]. There are two main control systems: the local control and the global control. The first one supervises positions and displacements of single parts of the interferometer (marionettes, mirrors), with respect to ground or to accelerometer signals. Its principal function is to reduce angular and longitudinal oscillations intrinsic in the super-attenuator chain. The second one deals with the relative

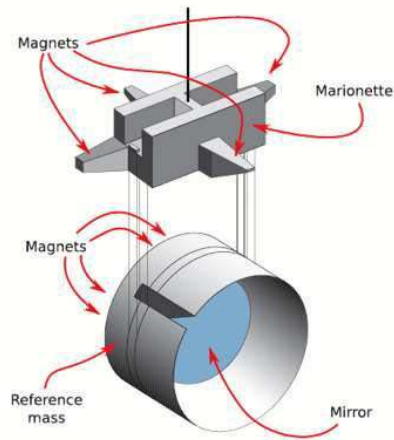

FIGURE 2. Scheme of the bottom part of the super-attenuator, including the marionette and the payload.

positioning and rotation of the mirrors along the optical axis of the system and assures the correct working point of the interferometer.

An important problem affecting interferometers for GW detection is the absorption of the mirrors, particularly in the input mirrors of the cavities. In fact, a lot of power is absorbed by these mirrors introducing a thermal lensing effect (thermal aberrations) which limits the performances of the system. In order to mitigate this problem, a thermal compensation system (TCS) has been implemented [13]. Virgo interferometer characterized by these features has been used in the second scientific run VSR2. The sensitivity curve of Virgo during VSR2 is shown in figure 3, compared to those of Ligo interferometers. Due to its advanced seismic isolation system, Virgo had the best sensitivity below 75 Hz. Due to the difference in cavity finesse and in the arms length (4 km for Ligo, 3 km for Virgo), Ligo sensitivity is better between 100 and 300 Hz.

RELEVANCE OF THE LOW FREQUENCY VIRGO SENSITIVITY

Gravitational waves sources are usually classified depending on the time evolution of the signal they generate: periodic sources like pulsars and in general spinning neutron stars or other massive bodies; quasi-periodic sources such as coalescing binary systems of neutron stars or black holes; impulsive sources (bursts) like supernovae or coalescing systems at the merging point; stochastic background of cosmological or astrophysical origin. In the binary systems formed by compact objects like stellar mass black holes (masses of $\sim 10M_{\odot}$) or neutron stars (masses of $\sim 1.4M_{\odot}$), orbital energy is continually lost according to gravitational wave emission; this causes the reduction of the orbital radius down to the coalescence. The amplitude of the coalescing binaries' signal grows as a power of the orbital frequency, which in turn increases as the orbital radius becomes smaller, up to a maximum frequency inversely proportional to the system's mass. The

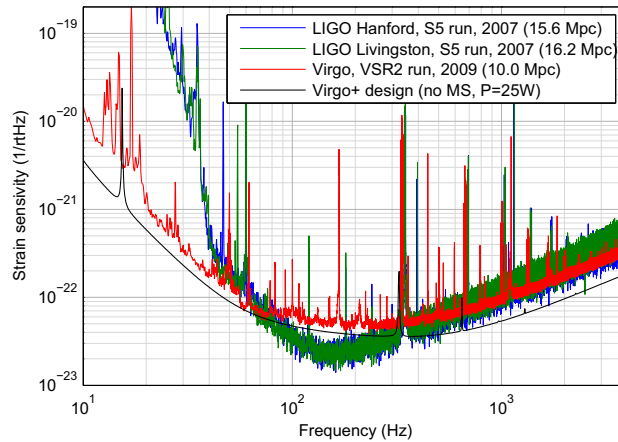

FIGURE 3. VSR2 Virgo strain sensitivity compared to Ligo sensitivities.

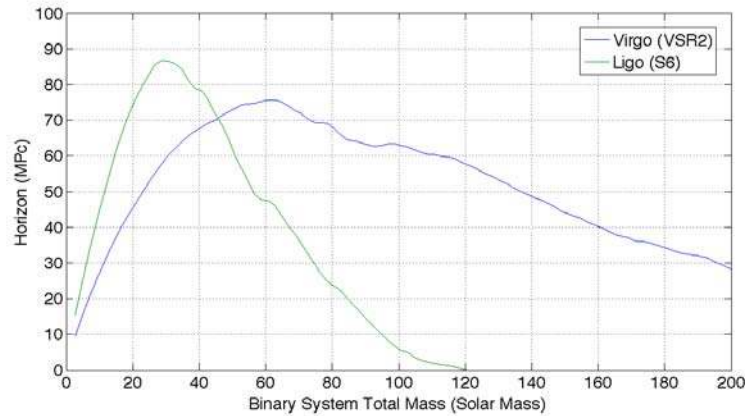

FIGURE 4. VSR2 Virgo horizon compared to Ligo horizon.

lower frequency cutoff of the detector determines therefore on one hand the effective duration of the signal, which for binary neutron stars lasts several tens of seconds in Virgo band, on the other hand sets a cutoff on the mass of the systems actually observable [14], [15], [16], [17], [18], [19].

The horizon is the maximum average distance at which a signal coming from a binary system of given solar mass coalescing is detectable with a Signal to Noise Ratio (SNR) equal to 8. In figure 4 the trend of the horizon versus binary system total mass is shown for Virgo during VSR2, compared to the one of Ligo. It can be seen that Virgo horizon is lower than Ligo one for binary systems of total mass $< 50 M_{\odot}$, whereas it maintains a remarkable horizon up to $200 M_{\odot}$ binary systems.

DETECTOR UPGRADES AND COMMISSIONING ACTIVITIES BEFORE VSR3

After the end of VSR2 some important hardware upgrades have been performed in order to optimize the performances of the interferometer. The most important upgrade is the replacement of the payloads of the Fabry-Perot cavities. The new mirrors are characterized by a higher reflectivity and are suspended to the marionette by silica fibers (monolithic suspensions) instead of steel wires. The higher reflectivity of the mirrors is expected to change the finesse of the cavity from 50 to 150, increasing the interferometer optical response by a factor 3. Moreover, the new mirrors are expected to be characterized by less absorption and, thus, less thermal lensing. The silica fibers are connected to the mirrors in a monolithic assembly, i.e. the mirrors, the clamping system and the wires are made of the same material, bonded by means of Hydroxide-Catalysis technique. The monolithic suspensions are essential to reduce the thermoelastic dissipations contribution to the thermal noise. Thus, it is expected to improve the Virgo sensitivity in the frequency range where it is limited by the intrinsic noise of the last stage of the suspension chain. The silica fibers employed in Virgo payloads are specifically produced (from a Suprasil rod) and tested in order to assure the required physical and geometrical properties. Every single fiber must carry a load of at least 5 kg, because the weight of a mirror is about 20 kg and it is suspended to four wires. In order to guarantee the automatic control of the payload, all the fibers must have exactly the same length of 70 cm. Moreover, also the intrinsic resonance frequencies of all the fibers must verify tight specifications in order to reduce the intrinsic thermal noise. A picture of the assembling of the mirrors and the silica fibers and a picture of the final payload are shown respectively in figure 5. Since the new payloads are very different from the old ones, also the local control system has been upgraded by changing some of its components. Up to now, Virgo is the only km-scale Earth based interferometer in which mirrors are suspended by a monolithic assembly; a similar scheme is operating since a few years in the smaller GEO600 detector [20].

The substitution of the four payloads of the two Fabry-Perot cavities is a big intervention in the interferometer, because all the working conditions are changed and must be recovered. After the substitution of the payloads a long period of commissioning activities has been spent in order to recover the complete functioning of the interferometer to be ready to re-join the data taking in common with Ligo with approximately the same sensitivity of VSR2. As expected some alignment and locking procedures have been changed because of the very different interferometer behavior. After reaching the dark fringe, the new input mirrors have been characterized in term of cavity finesse and absorption. The analysis and the measurement of the resonance peaks and of the pole of the Fabry-Perot cavities confirmed that the new finesse is around 150. Moreover, the measurement of the absorbed power in the input mirrors confirmed that the absorption of the new mirror is much smaller than the old one: the thermal aberrations were very well compensated. The interferometer has been re-locked and re-aligned in an aberration free configuration.

In addition to the payloads substitutions, also some electronic and software upgrades

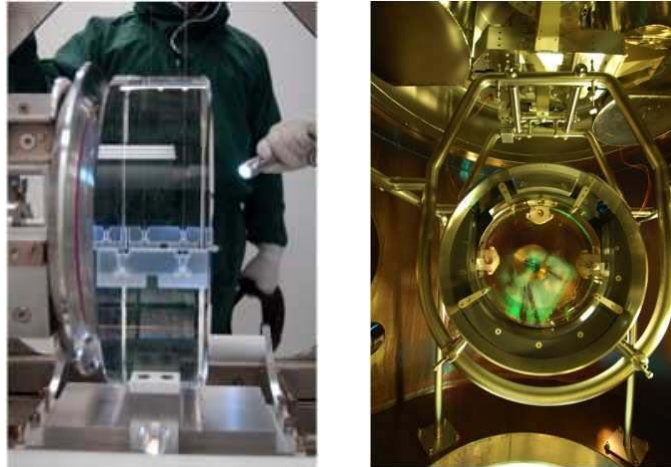

FIGURE 5. Payload assembling and Final Virgo Payload.

have been implemented. All the control signals of the Virgo interferometer are acquired by analog-to-digital converters (ADC) and processed by custom digital signal processor (DPS). In the interferometer shut-down all the DSP boards have been substituted and the DSP code was improved in order to reduce the introduced digital noise. Moreover, all the communications systems between the elements of the interferometer and the control system have been upgraded.

Thus, during the shut-down a big intervention has been made on the interferometer, and a long period was necessary in order to recover the interferometer. In fact, by considering both the assembling and the commissioning activities, the shut-down extended more than seven months. At mid August 2010 the interferometer was recovered with a sensitivity close to the one of VSR2 and the third data-taking in common with Ligo started. VSR3 finished at mid October 2010.

WORK IN PROGRESS AFTER THE END OF VSR3

After the end of VSR3 a long period of commissioning activities started. In fact, a lot of work must be done in order to study all the sources of noise that limit Virgo sensitivity. In particular, a long study has been made on the diffused light in the interferometer, which limits the sensitivity in the range between 40 and 100 Hz. One important intervention was the introduction of a new beam dump for the spurious output beam of the OMC. In fact, at the output of the new interferometer, there is a lot of power matched with the higher order modes that is filtered by the OMC producing its spurious output beam. It has been found that a part of this beam was re-introduced in the interferometer. Thus, a new beam dump was introduced near the output of the OMC strongly reducing the amount of diffused light in the interferometer. In order to obtain a better beams recombination at the output of the interferometer, the radius of curvature of the end mirrors must be as similar as possible. Thus, a heater has been installed near one of the two end mirror in order to deform a bit its surface and its radius of curvature.

After these interventions, it is foreseen the research and the study of the noise sources limiting the sensitivity.

An important noise source is the input beam jitter noise, which is mainly due to the seismic motion of the laser bench. Thus, it is under study a new bench that can attenuate this motion.

If the most part of the noise is solved, a strong work will be made in order to understand the effective functioning of the new monolithic suspensions. In fact a real comprehension of the thermal noise, which is one of the fundamental noises that limit the sensitivity, can be done only if all the other noises are removed. All the work will be done in order to organize a new scientific run (VSR4), which is foreseen in the summer 2011.

REFERENCES

1. <http://ww.virgo.infn.it>
2. <http://www.ligo.caltech.edu>
3. <http://geo600.aei.mpg.de>
4. <http://tamago.mtk.nao.ac.jp>
5. M. Lorenzini, "The monolithic suspension for the interferometer Virgo," *Class. Quantum Grav.*, **27**, 2010.
6. J. Y. Vinet et al., "The Virgo Physics Book, Vol. II," [<http://www.cascina.virgo.infn.it/vpb/>], 2004.
7. S. Braccini, "Measurement of the seismic attenuation performance of the VIRGO Superattenuator," *Astropart. Phys.*, **23**, 2005.
8. F. Acernese et al., "Measurement of Superattenuator seismic isolation by Virgo interferometer," *Astropart. Phys.*, **33**, 2010.
9. F. Acernese et al., "Performances of the Virgo interferometer longitudinal control system," *Astropart. Phys.*, **33**, 2010.
10. T. Accadia et al., "Performance of the Virgo interferometer longitudinal control system during the second science run," *Astropart. Phys.*, **34**, 2011.
11. F. Acernese et al., "Automatic Alignment for the first science run of the Virgo interferometer," *Astropart. Phys.*, **33**, 2010.
12. T. Accadia et al., "Automatic Alignment system during the second science run of the Virgo interferometer," *Astropart. Phys.*, **34**, 2011.
13. R. C. Lawrence, "Active wavefront correction in laser interferometric gravitational wave detectors," *PhD Thesis*, Massachusetts Institute of Technology, 2003.
14. S. Abbott et al., "Astrophysically Triggered Searches for Gravitational Waves: Status and Prospects," *Class. Quantum Grav.*, **25**, 2008.
15. D. A. Brown et al., "Prospects for detection of gravitational waves from intermediate-mass-ratio inspirals," *Phys. Rev. Lett.*, **99**, 2009.
16. T. Damour et al., "A comparison of search templates for gravitational waves from binary inspiral," arXiv:gr-qc/0010009v4.
17. T. Damour et al., "Frequency-domain P-approximant filters for time-truncated inspiral gravitational wave signals from compact binaries," *Phys. Rev. D*, **62**, 2000.
18. D. Buskulic, "Very Low Latency Search Pipeline for Low Mass Compact Binary Coalescences in the LIGO S6 and Virgo VSR2 Data," *GWDAW14 proceedings*, 2009.
19. F. Acernese et al., "Cleaning the Virgo sampled data for the search of periodic sources of gravitational waves," *Class. Quantum Grav.*, **26**, 2008.
20. H. Grote et al., "The GEO 600 status," *Class. Quantum Grav.*, **27**, 2010.