

Steep plasma gradients studied with spatially resolved Thomson scattering measurements

Citation for published version (APA):

Jonkers, J., Selen, L. J. M., Mullen, van der, J. J. A. M., Timmermans, E. A. H., & Schram, D. C. (1997). Steep plasma gradients studied with spatially resolved Thomson scattering measurements. *Plasma Sources Science and Technology*, 6(4), 533-539. <https://doi.org/10.1088/0963-0252/6/4/011>

DOI:

[10.1088/0963-0252/6/4/011](https://doi.org/10.1088/0963-0252/6/4/011)

Document status and date:

Published: 01/01/1997

Document Version:

Publisher's PDF, also known as Version of Record (includes final page, issue and volume numbers)

Please check the document version of this publication:

- A submitted manuscript is the version of the article upon submission and before peer-review. There can be important differences between the submitted version and the official published version of record. People interested in the research are advised to contact the author for the final version of the publication, or visit the DOI to the publisher's website.
- The final author version and the galley proof are versions of the publication after peer review.
- The final published version features the final layout of the paper including the volume, issue and page numbers.

[Link to publication](#)

General rights

Copyright and moral rights for the publications made accessible in the public portal are retained by the authors and/or other copyright owners and it is a condition of accessing publications that users recognise and abide by the legal requirements associated with these rights.

- Users may download and print one copy of any publication from the public portal for the purpose of private study or research.
- You may not further distribute the material or use it for any profit-making activity or commercial gain
- You may freely distribute the URL identifying the publication in the public portal.

If the publication is distributed under the terms of Article 25fa of the Dutch Copyright Act, indicated by the "Taverne" license above, please follow below link for the End User Agreement:

www.tue.nl/taverne

Take down policy

If you believe that this document breaches copyright please contact us at:

openaccess@tue.nl

providing details and we will investigate your claim.

Steep plasma gradients studied with spatially resolved Thomson scattering measurements

J Jonkers, L J M Selen, J A M van der Mullen†, E A H Timmermans and D C Schram

Department of Applied Physics, Eindhoven University of Technology, PO Box 513, 5600 MB Eindhoven, The Netherlands

Received 18 June 1997, in final form 3 September 1997

Abstract. Plasmas created by the microwave torch Torche à Injection Axiale (TIA), which are around 2 mm in diameter and 15 mm long, are investigated. In these plasmas large gradients are present so that the edge is supposed to play an important role. Using global Thomson scattering measurements, in which global refers to the fact that the size of the laser beam is approximately equal to the diameter of the plasma, the electron densities and temperatures were determined. However, these results lead to discrepancies in the particle balance: the production of free electrons is much larger than the classical losses due to recombination, convection and diffusion. Radially resolved Thomson scattering measurements show the plasma has a hollow structure. Although this enhances the losses due to diffusion, still a large discrepancy remains between production and destruction of free electrons in the argon plasmas. Probably some molecular processes are significant as well. A good candidate is the charge transfer between argon ions and nitrogen molecules, since mixing with the surrounding air has a large impact on the plasma.

1. Introduction

One of the most essential differences between laboratory and celestial plasmas, i.e. the difference in size, leads to the fact that laboratory plasmas have much steeper gradients and thus much larger related fluxes. This results in the presence of larger departures from equilibrium, which are larger the smaller the plasma.

Besides the deviation from local thermal equilibrium (LTE), as manifest in the inequality between the electron temperature T_e and the gas temperature T_g , most laboratory plasmas have an imbalance between electronic ionization and the corresponding backward process of three-particle recombination. The latter will affect the atomic state distribution function (ASDF) in such a way that its slope is not constant, but changes as a function of the excitation energy [1–3]. This means that the excitation temperature T_{exc} , which is related to the slope of the ASDF, is not clearly defined and can attain values which are greatly different from those of T_e and T_g . On the other hand the excitation temperature is relatively easy to determine and is widely used as a characteristic temperature for a plasma. However, for small plasmas there is no unique T_{exc} , so that the characterization of these plasmas is often associated

Table 1. Various reported temperatures for the Torche à Injection Axiale.

	Ref.	Argon (K)	Helium (K)
T_g	[6]	3000	2500
	[7, 8]	—	3000
T_{exc}	[3]	4860, 8700	3800, 11 400
	[7]	—	13 000
	[8]	—	12 500
T_e	[9]	17 000	25 000

with the presence of a large variety in temperatures, as is for instance shown in the paper of Snyder *et al* [4].

A typical example of a small plasma with a large temperature variation is a plasma produced by the Torche à Injection Axiale (TIA). This torch with axial gas injection is driven with typically 1 to 2 kW microwave power [5]. The typical dimensions of the plasma are 1 mm in the radial and 15 mm in the axial direction. The plasmas produced by the TIA expand in the open air. The various temperatures found in the literature [3, 6–9], as given in table 1, clearly show that there are large discrepancies and that the meaning of the various temperatures is still under discussion.

In the past we studied argon and helium plasmas produced by the TIA. In [3] absolute measurements of the densities of the excited states are presented. It was

† Author to whom all correspondence should be sent (e-mail address: j.j.a.m.v.d.mullen@phys.tue.nl).

found that the deduced T_{exc} values depend on the excitation energy of the levels taken into account. In argon excitation temperatures between 4860 and 8700 K were obtained and in helium between 3800 and 11 400 K. In the same paper it is concluded that apparently the ASDF is far from Saha–Boltzmann equilibrium, so that it is impossible to determine the electron temperature from emission spectroscopy and that the actual electron temperature has to be higher than the presented excitation temperatures.

This was confirmed by our second paper on the TIA [9] in which the electron temperature was obtained using Thomson scattering experiments. The found temperatures (typically 17 000 K for argon and 25 000 K for helium) are indeed higher than all other temperatures reported before. In spite of this large discrepancy it was not possible to find any indication for a deviation of the electron energy distribution function (EEDF) from a Maxwellian shape [9], as is claimed to be found by Huang *et al* [10] for a similar torch. We therefore concluded that the electron temperature is well defined and that it can be found by Thomson scattering and not (easily) via the variable slope of the ASDF.

The Thomson experiments in [9] were performed with a laser beam of around 1.5 mm in diameter, so that almost the whole plasma was radially imbedded in the beam. We will refer to these measurements as global Thomson measurements. It is the aim of this study to verify in how far the high T_e values as found by global Thomson scattering are consistent with the ionization as deduced from the electron particle balance. To obtain information on the diffusion, which is expected to be a dominant term of the particle balance, spatially resolved information is needed. Therefore Thomson experiments have been performed with a much smaller beam, a technique which we refer to as the local Thomson scattering method.

The TIA is an ideal plasma for the study of the relationship between the plasma interior and the (sharp) boundaries. The radius of the plasma is very small, so that the effect of steep gradients is surely present. On the other hand the plasma is large enough that, after considerable effort, it can still be subjected to a spatially resolved study. Insights obtained in this investigation might contribute to a better understanding of other plasmas as well. For instance, it is known that although in atmospheric cascaded arcs LTE is present in the main channel (due to the high electron density), deviations from LTE are found in the neighbourhood of the cathode [11, 12]. Another example is the edge of an atmospheric inductively coupled plasma (ICP), where (partly) due to entrainment of air [13], the gradient lengths are small and the fluxes high. In all these cases we essentially meet with the same phenomenon: boundaries with steep gradients which influence the properties of a considerable plasma part.

In this paper the particle balance of the TIA plasmas is discussed in section 2. By balancing the production and destruction of the free electrons, the electron temperature can be estimated [14]. It will turn out that the electron temperature, as found by the global Thomson scattering measurements [9], leads to a much too large production compared to the losses due to diffusion, if the radius of the

plasma is taken as the gradient length of the radial electron density profile. This demands more precise spatially resolved measurements which are presented in section 3. The resulting gradient is indeed much steeper than deduced from global considerations, but not steep enough to explain the high electron temperatures in the argon plasma. It is shown that if the air, in which the plasma normally expands, is replaced by argon the plasma is significantly different (section 4). The entrainment of air in the outer regions of the plasma appears to have a strong influence on the plasma as a whole.

2. The particle balance

If a plasma is in steady state the ionization, i.e. the production of ions and free electrons, equals the destruction by recombination and outward transport. This is represented by the particle balance for charged particles:

$$n_e n_1 S_{CR} - n_e n_+ \alpha_{CR} = \nabla \cdot (n_e \mathbf{w}_p) - \nabla \cdot (D_a \nabla n_e) \quad (1)$$

in which n_e , n_+ and n_1 refer to the electron, ion and atom ground state densities respectively. The terms on the right-hand side of equation equal the outward transport due to convection and ambipolar diffusion (mainly in radial direction) respectively and will be discussed below. The left-hand side represents the local net production. The ionization (S_{CR}) and recombination (α_{CR}) coefficients can be calculated using a collisional radiative (CR) model [1, 15, 16]. Here we will use the CR model by Benoy *et al* for argon [15]. Although this paper is focused on argon plasmas, we will make the same estimation for a helium plasma, operating at the same conditions. For this we use the model of Drawin and Emard [16]. In figure 1 the ionization coefficients for helium and argon are depicted versus the electron temperature. Due to the very high electron temperature (see table 1) recombination of atomic ions can be neglected.

The losses of charged particles due to convection, i.e. the first term on the right-hand side of equation (1), can be estimated by

$$\nabla \cdot (n_e \mathbf{w}_p) \approx \frac{n_e}{h_p} w_p \quad (2)$$

in which h_p is the scale length in the direction of the flow (for which 1 cm is taken) and w_p the flow velocity of the plasma (approximately 100 m s⁻¹). The other transport term, i.e. the flux due to diffusion, can be written as

$$|\nabla \cdot (D_a \nabla n_e)| \approx \frac{n_e}{\Lambda^2} D_a \quad (3)$$

in which Λ is the gradient length of the electron density profile, which we assume to be equal to the radius of the plasma (1 mm). An expression for the diffusion coefficient D_a can be found in [17]

$$D_a = \frac{3k_B}{8n_1 M \Omega (T_g)} (T_g + T_e) \quad (4)$$

with M the atom mass. For argon the ion–atom collision integral Ω is given by [17]

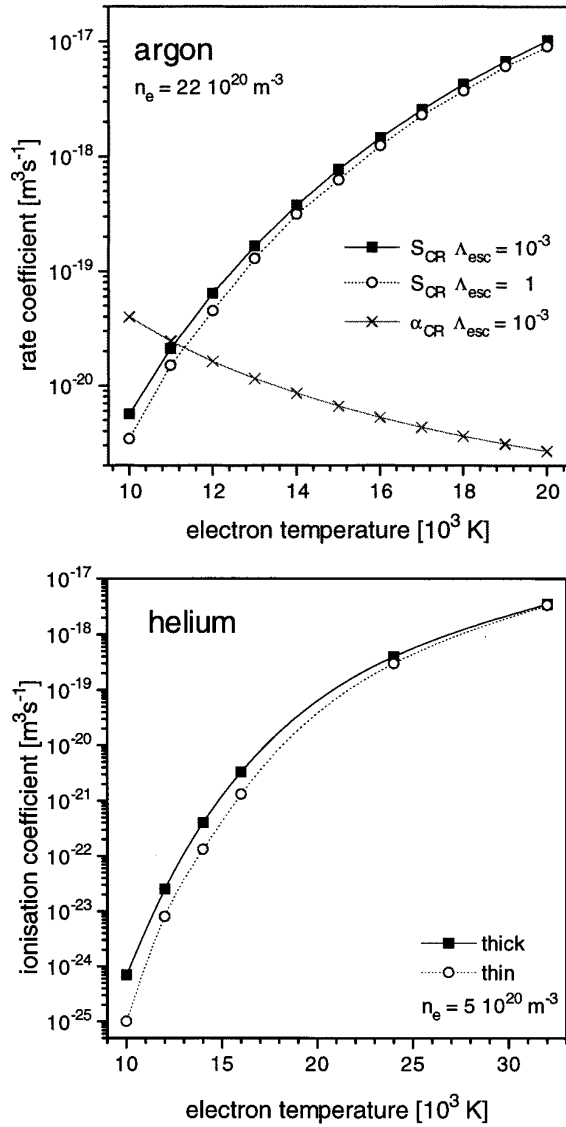

Figure 1. The ionization coefficient as a function of the electron temperature for argon [15] and helium [16]. In the case of argon the ionization coefficient is given for two different escape factors for resonance radiation: $\Lambda_{esc} = 1$ (i.e. optically open) and $\Lambda_{esc} = 10^{-3}$ (a more realistic one). The crosses represent the recombination coefficient. For helium the solid squares refer to a plasma which is optically thick for resonance radiation and the open circles to a complete optically thin plasma.

$$\Omega_{Ar}(T_g) = (3.03 + 6.82 \times 10^{-4} T_g - 3.70 \times 10^{-8} T_g^2 + 9.15 \times 10^{-13} T_g^3) \times 10^{-16} \text{ (m}^3 \text{ s}^{-1}) \quad (5)$$

and for helium by

$$\Omega_{He}(T_g) = (1.72 + 8.26 \times 10^{-4} T_g - 5.10 \times 10^{-8} T_g^2) \times 10^{-16} \text{ (m}^3 \text{ s}^{-1}). \quad (6)$$

For the gas temperature 3000 K is taken, see table 1, so that the density of the ground state equals $2.4 \times 10^{24} \text{ m}^{-3}$. Using these approximations and the T_e values as determined by global Thomson scattering measurements (cf [9] or table 1), the terms of the particle balance can be estimated. It should be noted that the exact value of the electron density

Table 2. Typical rates of the separate terms of the particle balance, using T_e and n_e as determined by global Thomson scattering measurements (17000 K and $22 \times 10^{20} \text{ m}^{-3}$ for argon and 25000 K and $5 \times 10^{20} \text{ m}^{-3}$ for helium [9]). The diffusion loss rates are obtained using a radial gradient length of 1 mm.

	Argon (s^{-1})	Helium (s^{-1})
Ionization	6×10^6	1×10^6
Recombination	1×10^1	6
Convection	1×10^4	1×10^4
Diffusion	1×10^3	2×10^4

is not important, since the dominant terms of equation (1) scale with n_e . The radial distribution of the electron density, however, influences the electron temperature via the diffusion term. The magnitudes of each term of the particle balance divided by the electron density are listed in table 2.

A comparison of the ionization with the three loss terms shows that the production outranges the destruction by roughly two orders. This might be due to a too high electron temperature. However, if for the helium plasma the temperatures are taken which are found by passive emission spectroscopy (around 12500 K) [3, 7, 8], the ionization frequency becomes $1 \times 10^2 \text{ s}^{-1}$, which is even too small to balance the losses due to convection ($1 \times 10^4 \text{ s}^{-1}$, see table 2). Therefore an electron temperature much higher than 12500 K is needed to sustain the plasma.

Although one could argue that T_e could be somewhere in between the values as determined by the passive and active (Thomson) techniques, we assume in the following that the electron temperature obtained by global Thomson scattering is correct. In this case the apparent imbalance as indicated by table 2 can have two reasons:

- the effective ionization is smaller for the given T_e values or
- the loss terms are larger in reality.

First we investigate the effective ionization. The ionization coefficient depends on the escape factor of resonance radiation. A higher escape factor will disfavour the stepwise excitation and therefore decrease the ionization. The escape factor depends on the spectral line profile which is partly determined by Van der Waals or pressure broadening [18]. Besides broadening, this process can cause a shift in the wavelength and therefore it strongly affects the escape factor. The Van der Waals interaction is due to the interaction between atoms, so that it depends on the atom density. In small plasmas, as produced by the TIA, large gradients in the gas temperature (and therefore in the atom density) are probably present, so that the Van der Waals line shift can increase drastically the escape factor, which results in a lower ionization rate.

In figure 1 the ionization coefficient in argon is depicted for two escape factors of the resonance radiation: 10^{-3} (squares) and 1 (circles). It can be seen that the influence of the escape factor is limited, especially at the high electron temperatures present in the TIA plasmas. Also for helium

this is the case, as can be seen in figure 1. The basic reason for this insensitivity of radiation escape is the relatively high electron density (in the order of 10^{21} m^{-3} , see [9] or next section) due to which the population of the excited states is determined by (inelastic electron) collisions rather than radiative processes [1].

Therefore we assume that the ionization coefficients are correct, so that the loss terms have to be underestimated. The actual losses can be higher due to

- (1) formation and destruction of molecular rare gas ions,
- (2) mixing with the surrounding air or
- (3) a smaller gradient length.

2.1. Formation and destruction of molecular rare gas ions

Due to the formation of rare gas molecular ions

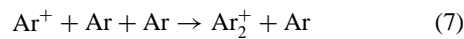

followed by the destruction via dissociative recombination

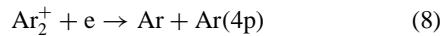

charged particles are lost. Normally, the formation of the molecular ion is the limiting process. This frequency is around $1 \times 10^6 \text{ s}^{-1}$ in the argon plasma for a neutral density equal to $2.4 \times 10^{24} \text{ m}^{-3}$ [19]. However, the argon atom in the 4p state, which is produced by the second reaction, is easily ionized again, since (radiative) decay to the ground state is not likely (see above). Moreover, the formation of molecular ions is also accompanied by its inverse process, so that the resulting ion loss rate of this channel is much smaller than the ionization rate ($6 \times 10^6 \text{ s}^{-1}$). Therefore we conclude that the formation and destruction of molecular argon ions play a minor role in the particle balance of these plasmas.

2.2. Mixing with the surrounding air

Extra destruction channels for free electrons are created if the surrounding air is mixed with the plasma. For instance, for argon and nitrogen a possible mechanism is charge transfer

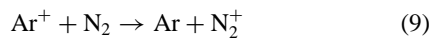

followed by dissociative recombination



The charge transfer reaction is resonant since the ionization energies of argon and molecular nitrogen are almost equal (15.76 and 15.58 eV respectively). The second reaction is fast due to the attractive Coulomb interaction between the positively charged molecule and the electron. The possible presence of nitrogen is supported by the fact that in the plasma the first negative system of N_2^+ and many atomic nitrogen lines can be observed [6, 7]. At low power levels (<1 kW) also the second positive system of N_2 is strongly present. Moreover, a significant entrainment of air

into an ICP, which is also expanding in the open air, was measured by de Regt and co-workers [13].

The rate coefficient of the charge transfer reaction is about $4 \times 10^{-16} \text{ m}^3 \text{ s}^{-1}$ [20], so that if 1% of the heavy particles in the plasma are nitrogen molecules this destruction channel is more than fast enough to balance the ionization. The significance of such kinds of mechanism is investigated by controlling the environment in which the plasma expands (see section 4).

2.3. A smaller gradient length

Another possible explanation for the large discrepancy between the ion production and the destruction rates might be that the actual radial gradient length is smaller than the value of 1 mm, which is used for estimating the diffusion losses in table 2. An indication of the gradient length is obtained by the skin effect. The penetration of the microwaves into the plasma is limited, since they are absorbed by the free electrons. As can be found in e.g. Jackson [21] the skin depth is given by

$$\delta = \sqrt{\frac{1}{\pi \mu_0 \sigma f}}. \quad (11)$$

For an argon plasma under our conditions the conductivity σ is approximately $10^4 \text{ } \Omega^{-1} \text{ m}^{-1}$ [22], so that due to the high frequency of the microwaves ($f = 2.45 \text{ GHz}$) the skin depth is only 0.1 mm. If we assume that the gradient length of the electron density equals the skin depth instead of the (global) plasma radius, the diffusion losses will increase by two orders, cf equation (3). As can be concluded from table 2 this is sufficient to satisfy the particle balance for the helium plasma, but not enough for the argon plasma. However, this is only an estimation of the gradient length. The actual gradient length has to be obtained from the radial distribution of the electron density, which requires a spatially resolved measurement technique.

3. Experimental determination of the gradient length

For the measurements of the radial gradient length, the same set-up is used as for the previously reported global Thomson scattering measurements [9, 23]. The main difference is that now the laser beam is focused at the position of the plasma, in order to obtain a good spatial resolution. In the past [23] the focus of the laser beam was situated behind the plasma to avoid the possibility that stray light from the ablation of dust particles is detected during the calibration procedure. To avoid interference with this signal a dust free chamber is constructed surrounding the plasma, for the measurements presented now.

In figure 2 the radially resolved electron density and temperature profiles are depicted. These measurements are taken at 2 mm above the nozzle (AN) using 1.0 kW input power and 3.0 slm argon. Due to the construction of the TIA the reflected power can be tuned easily to a negligible level (<2%) [5]. Every point in figure 2 is obtained using 2500 laser shots with approximately 0.26 J per shot.

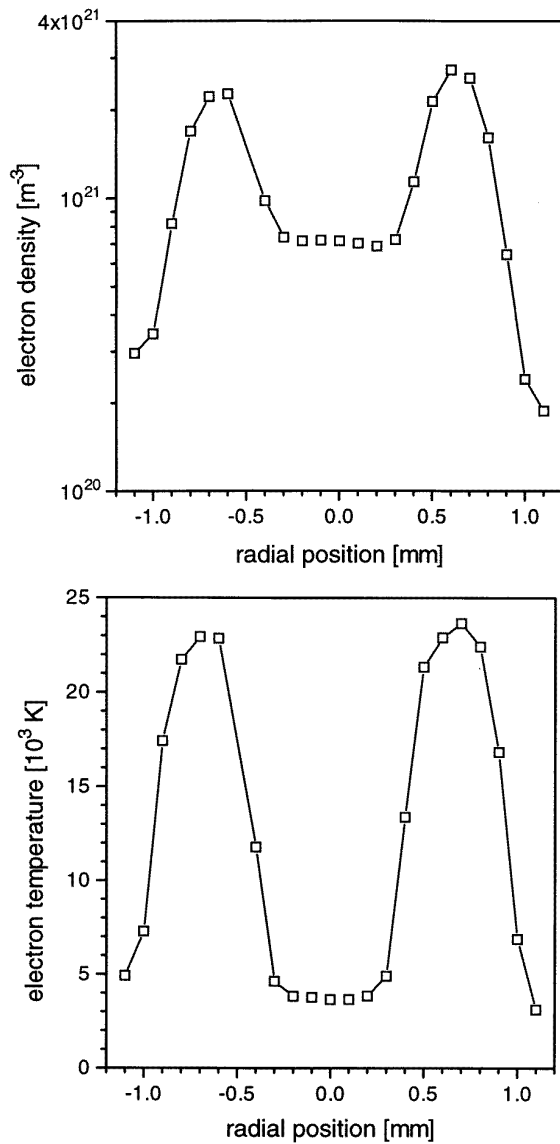

Figure 2. The radial electron density and temperature profiles in an argon plasma at 2 mm above the nozzle (1.0 kW and 3.0 slm), obtained by local Thomson scattering. The density profile seems to have a doughnut-like shape. The steep outer gradients increase the losses due to diffusion.

Both the density and the temperature profile appear to have a hollow structure. Owing to this the measured radial gradient length is approximately 0.2 mm. As is discussed at the end of section 2 a gradient length of 0.1 mm is not enough to balance the ionization in the argon plasma. Therefore it has to be concluded that the gradient length might be even smaller or that molecular recombination channels are also important.

It appears to be very difficult to perform the same measurements for the helium plasma with this set-up. Due to the lower electron density the area of the Thomson scattering profile is lower and due to the higher electron temperature the profile is also more broadened. Both effects lead to a much lower number of photons per wavelength interval compared to the argon plasma. If we assume that

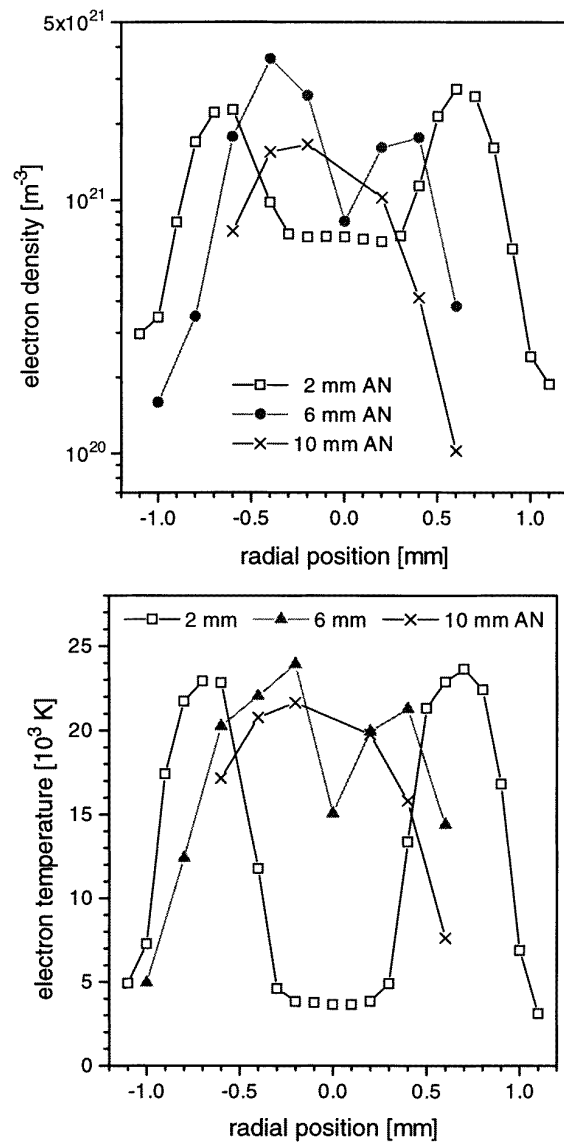

Figure 3. The dependence of the radial profiles on the height above the nozzle (AN). Close to the nozzle both the electron density and temperature appear to have a doughnut-like shape. This doughnut narrows downstream and at 10 mm AN it becomes more like a candle flame.

the gradient length in helium is the same as in argon, the actual diffusion losses are 25 times higher than was estimated in table 2, so that they become of the same order as the ionization.

As can be seen in figure 2 the maxima of the electron density and temperature are situated at $r = \pm 0.7$ mm, which is closer to the centre than the edges of the nozzle (at $r = \pm 0.9$ mm). In figure 3 measurements at different axial positions are depicted. The larger the distance to the nozzle, the more the maxima of n_e and T_e are shifted towards the centre of the plasma. At 10 mm AN the plasma is located at the centre. The reason for the hollow shape close to the nozzle is probably the skin effect. During the time the free electrons need to diffuse to the centre, they are also transported downstream by the flow of the plasma. Meanwhile the free electrons at the outside are destroyed

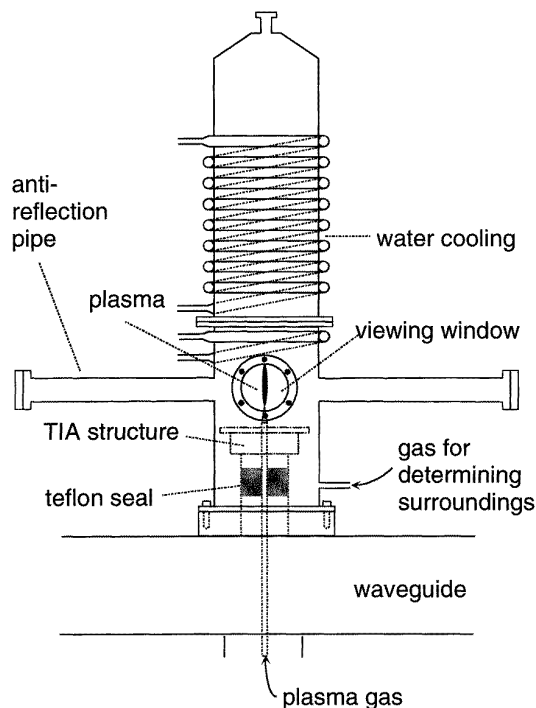

Figure 4. The set-up for the determination of the influence of the surrounding atmosphere on the plasma.

most likely by the entrained nitrogen molecules (see next section).

More downstream the flame becomes very turbulent, so that measurements of the electron temperature and density are difficult, since the Thomson scattering signal is much weaker (due to the lower electron density) and moreover it is disturbed by rotational Raman scattering. This means that for this region mixing with the surrounding air certainly cannot be neglected.

4. The influence of the surrounding atmosphere

As stated in section 2 mixing with the surrounding atmosphere can have a strong influence on the plasma. In case of the TIA this is investigated by placing a special vessel on top of the rectangular waveguide structure, see figure 4. The vessel is flushed with either argon or air (3 slm). The plasma (argon) gas flow is 1.8 slm and the applied microwave power 0.6 kW.

Using the same high-resolution Thomson scattering set-up, the electron density and temperature are measured as a function of the radius at 5 mm above the nozzle. The results are depicted in figure 5. The plasma which is sustained in an air atmosphere is more or less the same as the one expanding in the open air (i.e. without the metal vessel). There are some slight differences which are probably due to the facts that the microwave power is lower and that the metal vessel has some small influences on the shape of the EM field and on the flowing pattern of the gas. However, when the air is replaced by argon, the plasma radius becomes much larger and the electron temperature slightly lower. This confirms that mixing

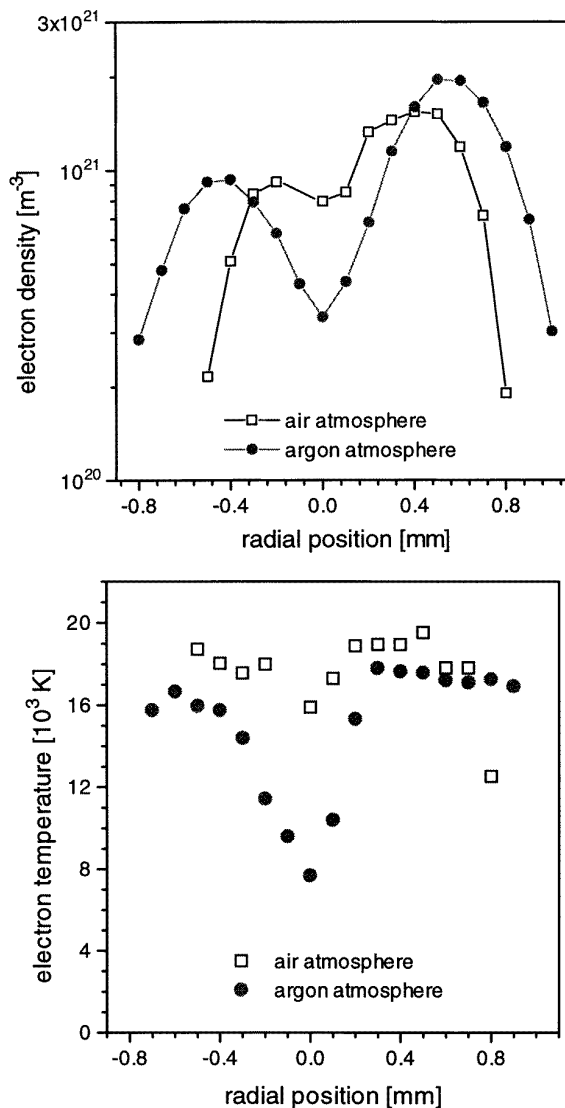

Figure 5. The influence of the surrounding atmosphere on the plasma. In an argon atmosphere the plasma is larger, allowing a lower electron temperature. These measurements are taken at 5 mm AN.

with the surrounding gas is an important mechanism. To determine the quantitative effect of the air entrainment on the particle balance measurements of the molecular nitrogen density are necessary. In the past this was done in our laboratory using vibrational Raman scattering on an atmospheric ICP [13]. However, in that case a laser beam with a large diameter was used, which is not suitable in case of the TIA.

5. Conclusions

Due to the small dimensions of the plasmas created by the TIA high electron temperatures are necessary to sustain these plasmas. However the temperatures, obtained by Thomson scattering using a laser beam whose diameter has the same magnitude as that of the plasma, are higher than those which are needed to compensate for the estimated

classical losses due to diffusion, flow and recombination. For a thorough understanding of the plasma radially resolved measurements of the electron density proved to be necessary. These measurements show that the plasma has a doughnut-like shape close to the nozzle, which means that the diffusion losses based on a global consideration are underestimated. For helium the corrected diffusion seems to balance more or less the production. However, in argon the losses due to diffusion are not large enough, which indicates that other mechanisms play a significant role as well. This is probably charge transfer between argon ions and nitrogen molecules and subsequent dissociative recombination of the molecular ion, since the surrounding air influences the plasma.

Acknowledgments

The authors want to thank Professor M Moisan, who kindly gave us permission to use the TIA design. Our TIA was built by F J Overberg and the vessel for the determination of the influence of the surroundings by G ter Plegt. A part of the microwave equipment was donated by Philips Research Laboratories Eindhoven. A Hartgers revised the CR model of D A Benoy.

References

- [1] van der Mullen J A M 1990 *Phys. Rep.* **191** 109
- [2] Jonkers J and van der Mullen J A M 1997 *J. Quant. Spectrosc. Radiat. Trans.* submitted
- [3] Jonkers J, Vos H P C, van der Mullen J A M and Timmermans E A H 1996 *Spectrochim. Acta B* **51** 457
- [4] Snyder S C, Reynolds L D, Fincke J R, Lassahn G D, Grandy J D and Repetti T E 1994 *Phys. Rev. E* **50** 519
- [5] Moisan M, Sauv e G, Zakrzewski Z and Hubert J 1994 *Plasma Sources Sci. Technol.* **3** 584
- [6] Ricard A, St-Onge L, Malvos H, Gicquel A, Hubert J and Moisan M 1995 *J. Physique III* **5** 1269
- [7] Rodero A, Garc a M C, Quintero M C, Sola A and Gamero A 1996 *J. Phys. D: Appl. Phys.* **29** 681
- [8] Rodero A, Quintero M C, Sola A and Gamero A 1996 *Spectrochim. Acta B* **51** 467
- [9] Jonkers J, de Regt J M, van der Mullen J A M, Vos H P C, de Groote F P J and Timmermans E A H 1996 *Spectrochim. Acta B* **51** 1385
- [10] Huang M, Hanselman D S, Jin Q and Hieftje G M 1990 *Spectrochim. Acta B* **45** 1339
- [11] Haddad G N and Farmer A J D 1984 *J. Phys. D: Appl. Phys.* **17** 1189
- [12] Megy S, Baronnet J-M and Ershov-Pavlov E A 1995 *J. Phys. D: Appl. Phys.* **28** 344
- [13] de Regt J M, de Groote F P J, van der Mullen J A M and Schram D C 1996 *Spectrochim. Acta B* **51** 1527
- [14] Lieberman M A and Lichtenberg A J 1994 *Principles of Plasma Discharges and Materials Processing* (New York: Wiley)
- [15] Benoy D A, van der Mullen J A M and Schram D C 1991 *J. Quant. Spectrosc. Radiat. Transfer* **46** 195
- [16] Drawin H W and Emard F 1971 *Z. Phys.* **243** 326
- [17] Jonkers J, van der Mullen J A M and Schram D C 1997 *Phys. Rev. E* submitted
- [18] Mitchell A C G and Zemansky M W 1961 *Resonance Radiation and Excited Atoms* (London: Cambridge University Press)
- [19] Schram D C, van der Mullen J A M, de Regt J M, Benoy D A, Fey F H A G, de Groote F P J and Jonkers J 1996 *J. Anal. At. Spectrom.* **11** 623
- [20] Smith D and Adams N G 1981 *Phys. Rev. A* **23** 2327
- [21] Jackson J D 1975 *Classical Electrodynamics* (New York: Wiley)
- [22] Aubreton J, Bonnefoi C and Mexmain J M 1986 *Revue Phys. Appl.* **21** 365
- [23] de Regt J M, Engeln R A H, de Groote F P J, van der Mullen J A M and Schram D C 1995 *Rev. Sci. Instrum.* **66** 3228