

SAND--90-1039

DE91 000087

SAND90-1039
UC-515
Unlimited Release
Printed August 1990

STELLAR SYSTEMS INC.
SERIES 800/5000 E-FIELD
SENSOR EVALUATION

Robert L. Follis
Sandia National Laboratories
Intrusion Detection Systems Technology Division 5249
Albuquerque, New Mexico

ABSTRACT

This report concerns the evaluation of the Stellar Systems Inc. E-Field intrusion detection system Series 800 control unit and the 5000 Series hardware components. Included are functional descriptions, installation procedures, testing procedures, and testing/operational results.

MASTER

EB

ACKNOWLEDGEMENTS

The author gratefully acknowledges the contributions of several individuals to the successful completion of the testing of this sensor. Sandia National Laboratories employees providing technical support for this project were the following: Dave Hayward provided valuable historical data and input on test procedures, having tested the early models of the Stellar Systems E-Field; Larry Miller provided AutoCAD and report content support; George Greer provided site preparation and material acquisition support; and Ken Ream provided support with data collection.

Personnel employed by companies other than Sandia providing support were Roger P. Case, Geo-Centers Inc., who provided major support during the installation and testing phases and produced the software necessary to calculate the field strength plots; Jim Blum, L & M Technologies Inc., who provided support during the installation phase and assisted with data collection; and Doug La Barge who with the technical training staff of Stellar Systems Inc., provided training and necessary information about previous tests.

CONTENTS

	<u>Page</u>
1.0 INTRODUCTION.....	1
2.0 SYSTEM DESCRIPTION, INSTALLATION, AND OPERATION.....	2
2.1 Equipment Description.....	2
2.2 Installation Requirements.....	2
2.3 System Operation.....	3
3.0 SYSTEM TESTING.....	6
3.1 Test Installation.....	6
3.2 Detection Testing.....	9
3.2.1 Normal Walk Test.....	9
3.2.2 Shuffle Walk Test.....	9
3.2.3 Climb-Through Test.....	11
3.2.4 Jump-Through Test.....	11
3.2.5 Lower Wire Lift Test.....	12
3.2.6 Large Target Approach Test.....	13
3.2.7 Small Target Approach Test.....	13
3.2.8 Changing Ground Potential Test.....	14
3.2.9 Water Runoff Test.....	14
3.2.10 Field Strength Pattern Plots.....	15
3.2.11 Alarm Comparison Tests.....	39
4.0 CONCLUSIONS AND RECOMMENDATIONS.....	44
APPENDIX A COMPARISON OF SERIES 600 AND 800 SYSTEMS.....	A-1
APPENDIX B PROCEDURE FOR GROUNDING THE INSULATORS USED ON E-FIELD SENSORS MOUNTED ON FREESTANDING FIBERGLASS POSTS.....	B-1
APPENDIX C CONTROL UNIT CALIBRATION PROCEDURE.....	C-1
APPENDIX D E-FIELD DETECTION PATTERNS SUPPORT DATA.....	D-1
APPENDIX E DATA COLLECTION SYSTEM DATA FOR 1989 FOR ENVIRONMENT RELATED ALARMS.....	E-1
APPENDIX F DATA COLLECTION SYSTEM DATA FOR 1989 FOR E-FIELD SENSOR MOUNTED ON FIBERGLASS POSTS.....	F-1
APPENDIX G DATA COLLECTION SYSTEM DATA FOR 1989 FOR E-FIELD SENSOR MOUNTED ON STEEL POSTS.....	G-1

FIGURES

		<u>Page</u>
1	Typical Stellar Systems Four-Wire Freestanding E-Field Sensor with Series 5000 Hardware.....	1
2	Series 800 E-Field Block Diagram.....	4
3	The Two Sensors Installed in the Area III Test Field.....	6
4	The Two Controllers Mounted away from the Sensor End Posts.....	7
5	Grounding of Insulators on Fiberglass Posts.....	8
6	E-Field Detection Pattern Plots.....	10
7	Lower Wire Lift Test.....	12
8	Wooden Frame Constructed for Measuring Field Strength Patterns.....	15
9	Two by Four Laying on the Ground with the Bared Coax Inserted in a Predrilled Hole.....	16
10	Two Views of Coax in Place for Measurement to be Taken near a Post.....	17
11	Field Strength Levels Measured in Decibels: Measurements Taken at Fiberglass Post.....	18
12	Field Strength Plot Shown with 1-Foot by 1-Foot Grid: Measurements Taken at Fiberglass Post.....	19
13	Field Strength Plot Shown without 1-Foot by 1-Foot Grid: Measurements Taken at Fiberglass Post.....	20
14	Field Strength Levels Measured in Decibels: Measurement Taken between Two Fiberglass Posts.....	21
15	Field Strength Plot Shown with 1-Foot by 1-Foot Grid: Measurements Taken between Two Fiberglass Posts.....	22
16	Field Strength Plot Shown without 1-Foot by 1-Foot Grid: Measurements Taken between Two Fiberglass Posts.....	23
17	Field Strength Levels Measured in Decibels: Measurements Taken at Ungrounded Steel Post.....	24

FIGURES
(continued)

	<u>Page</u>
18 Field Strength Plot Shown with 1-Foot by 1-Foot Grid: Measurements Taken at Ungrounded Steel Post.....	25
19 Field Strength Plot Shown without 1-Foot by 1-Foot Grid: Measurements Taken at Ungrounded Steel Post.....	26
20 Field Strength Levels Measured in Decibels: Measurements Taken between Two Ungrounded Steel Posts.....	27
21 Field Strength Plot Shown with 1-Foot by 1-Foot Grid: Measurements Taken between Two Ungrounded Steel Posts.....	28
22 Field Strength Plot Shown without 1-Foot by 1-Foot Grid: Measurements Taken between Two Ungrounded Steel Posts.....	29
23 Field Strength Levels Measured in Decibels: Measurements Taken at Grounded Steel Post.....	30
24 Field Strength Plot Shown with 1-Foot by 1-Foot Grid: Measurements Taken at Grounded Steel Post.....	31
25 Field Strength Plot Shown without 1-Foot by 1-Foot Grid: Measurements Taken at Grounded Steel Post.....	32
26 Field Strength Levels Measured in Decibels: Measurements Taken between Two Grounded Steel Posts.....	33
27 Field Strength Plot Shown with 1-Foot by 1-Foot Grid: Measurements Taken between Two Grounded Steel Posts.....	34
28 Field Strength Plot Shown without 1-Foot by 1-Foot Grid: Measurements Taken between Two Grounded Steel Posts.....	35
29 Field Strength Levels Measured in Decibels: Measurements Taken between Two Fiberglass Posts with Dummy Wires Installed.	36
30 Field Strength Plot Shown with 1-Foot by 1-Foot Grid: Measurements Taken between Two Fiberglass Posts with Dummy Wires Installed.....	37

FIGURES
(concluded)

	<u>Page</u>
31 Field Strength Plot Shown without 1-Foot by 1-Foot Grid: Measurements Taken between Two Fiberglass Posts with Dummy Wires Installed.....	38
32 Graph of Weather-Related Alarms.....	40
33 Graph of Total E-Field Alarms on Both Sensors.....	41
34 Graph of Alarms for E-Field Mounted on Fiberglass Posts.....	42
35 Graph of Alarms for E-Field Mounted on Steel Posts.....	43
C-1 Crawl Test.....	C-4

1.0 INTRODUCTION

The Stellar Systems EF-800 E-Field Perimeter Protection System is an exterior intrusion detection sensor that most commonly consists of three or four wires installed at varying heights parallel to each other and the terrain (Figure 1). The EF-800 employs electrostatic field volumetric detection technology designed specifically to detect an intruder attempting to penetrate the vertical plane between any of the wires or between the lower wire and ground. The E-Field sensor is terrain following and can be installed in various configurations: on existing fence posts, on free-standing posts, around corners, up walls, and across roofs.

This sensor was designed for medium to high security applications. It is specified to detect a human weighing more than 75 pounds moving from 6 inches to 25 feet per second with a probability of detection greater than 95%.

This document reports the evaluation of the E-Field sensor installation, calibration, and detection ability, and the determination of field strength and nuisance alarm/false alarm sources.

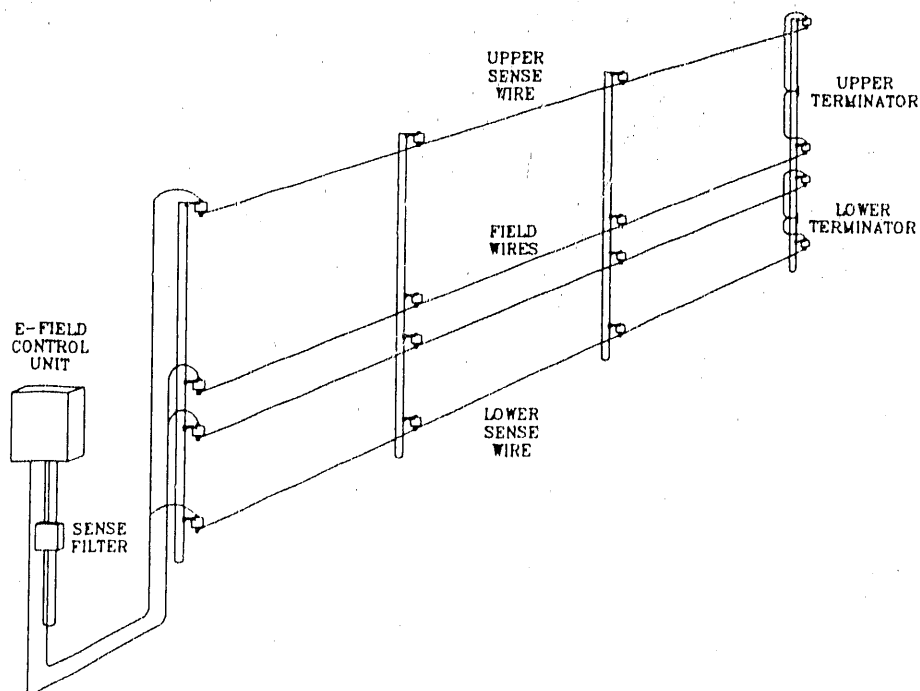

Figure 1. Typical Stellar Systems Four-Wire Freestanding E-Field Sensor with Series 5000 Hardware

2.0 SYSTEM DESCRIPTION, INSTALLATION, AND OPERATION

2.1 Equipment Description

The equipment required to cover a straight 100-meter sector with a complete four-wire freestanding system consists of the following:

- 1 each EF-810/115 single zone processor,
- 1 each 8333 sense filter,
- 2 each rolls 2361-2 coated (or 2382 uncoated) 305 stainless steel wire,
- 1 each 8348-4 (or 8358-4 remote test) terminator,
- 1 each 8349-4 (or 8359-4 remote test) terminator,
- 4 each 5014 winders,
- 4 each 2350 high tension springs,
- 4 each 5013 connecting links,
- 8 each 5012 terminal boot kits,
- 8 each 5020 tension insulator assemblies, and
- 64 each 5001 interim insulator assemblies.

This equipment was purchased from Stellar Systems Inc., 3511 Leonard Court, Santa Clara, California 95054 (408-496-6690) for \$7510.00. This price does not include the posts, hose clamps, coaxial wire, ground rods, miscellaneous hardware, or installation labor.

Additional hardware from Stellar Systems Inc. to mount the E-Field sensor on an existing fence will cost approximately \$165.00 per post.

2.2 Installation Requirements

The E-Field sensor can be installed using any one of several combinations of mounting structures and wire configurations. Mounting structures include existing fences, freestanding posts, walls, and buildings. The wire configurations in which the E-Field can be installed include three-wire, four-wire, five-wire (three active wires plus two dummy wires), six-wire (four active wires plus two dummy wires), eight-wire (two stacked four-wire sensors), and twelve-wire (eight active wires plus four dummy wires). The dummy wires must always be placed between the sense and field wire pairs, therefore the number of dummy wires should always be even for system balancing.

The maximum distance between posts should not exceed 20 feet and a uniform lower wire height of 6 to 10 inches above the terrain should be maintained. To allow the E-Field to be terrain following, posts must be installed at low and high points in the sector to keep the lower wire as uniform as possible above the terrain.

Proper grounding of certain E-Field components is very important. A wire of 14 AWG minimum size should be used to route the end terminators' ground wires to a 10-foot, copper-clad ground rod driven into the earth near the terminators. Terminal 18 of the processor must also be connected to a ground rod installed near the processor.

2.3 System Operation

The E-Field sensor consists of circuitry that produces an electrostatic field by transmitting a 100-volt RMS (300-volt PP) operating frequency signal on a field wire or pair of field wires (Table 1).

TABLE 1
PROCESSOR OPERATING FREQUENCIES

<u>Power Frequency</u>	<u>Channel</u>	<u>Crystal Frequency</u>	<u>Operating Frequency</u>
60 Hz	A	2.4960 MHz	9.750 kHz
60 Hz	B	2.4652 MHz	9.630 kHz
60 Hz	C	2.54208 MHz	9.930 kHz
60 Hz	D	2.43456 MHz	9.510 kHz
50 Hz	W	2.4384 MHz	9.525 kHz
50 Hz	X	2.4896 MHz	9.725 kHz
50 Hz	Y	2.4640 MHz	9.625 kHz
50 Hz	Z	2.5280 MHz	9.875 kHz

This signal is received on the sense wires. People, animals, or conductive objects entering this electrostatic field and sudden environmental disturbances such as lightning or rain alter the characteristics of the signal received by the sense wires. These altered characteristics change the current flowing in the sense wires.

Sudden environmental disturbances tend to have equal effect on both sense wires simultaneously. To minimize the nuisance alarms generated by these environmental disturbances, the series EF-800 sensor was designed to operate in a balanced phase mode. This balanced phase operation is accomplished by installing a sense filter between the sense wires and the controller.

The sense filter is a transformer with the center tap of the primary winding and the low side of the secondary winding grounded (Figure 2). The two sense wires are connected to the high and low sides of the sense filter transformer primary. The high side of the sense filter transformer secondary is connected to the input of the controller. Because the two sense wires are attached to the center tap grounded primary of the transformer, signals that exist on both sense wires at the same time and strength cancel out. Stellar calls this action "Common-Mode-Rejection."

The system capacitance (the terminators plus the natural capacitance between the field wires, sense wires, and ground) imposes a 90-degree phase shift of the signal on the sense wires with reference to the signal on the field wire. The sense filter adds another 180 degrees to the phase shift to total 270 degrees when the signal enters the controller at the sense input.

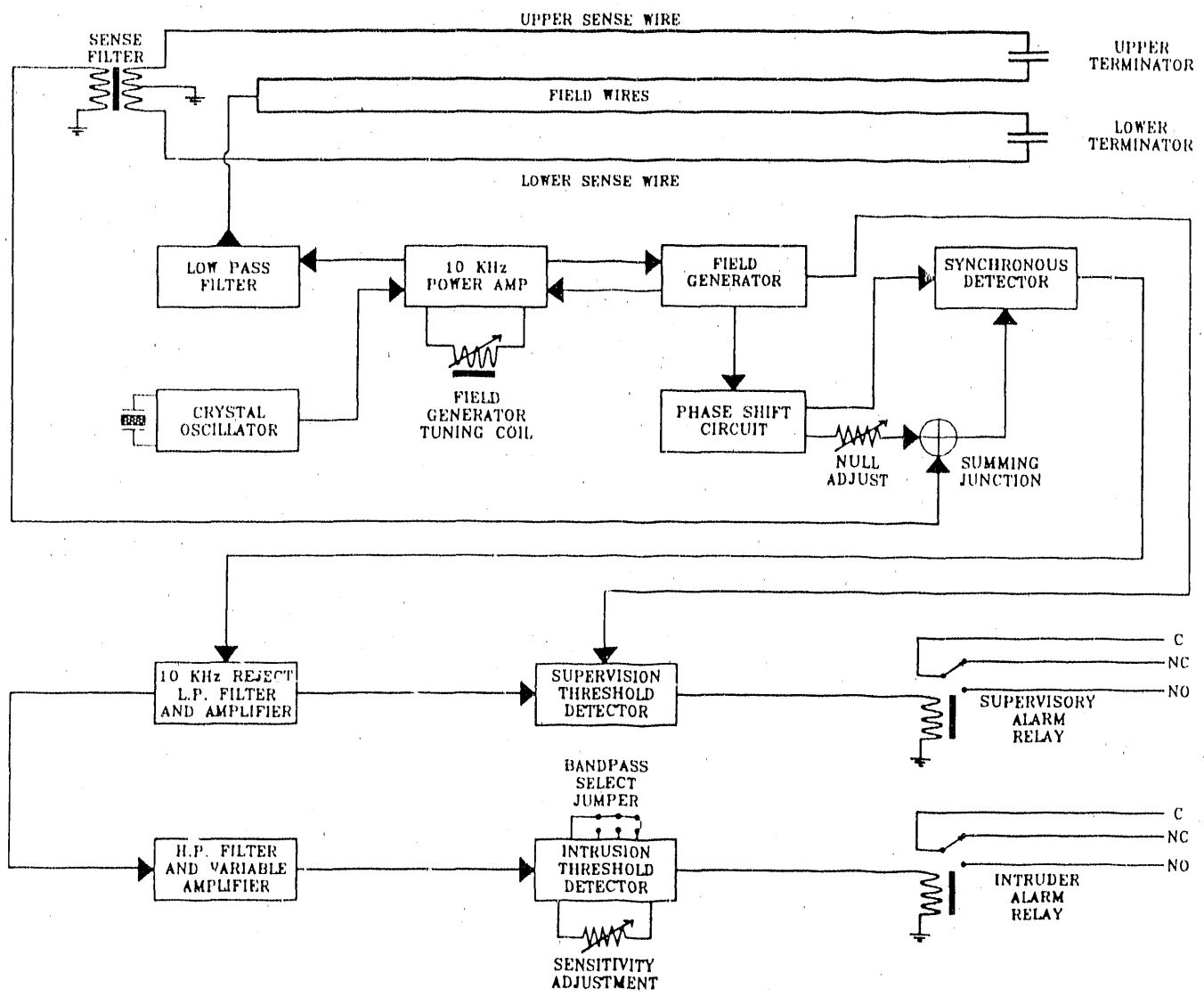

Figure 2. Series 800 E-Field Block Diagram

Inside the controller the signal present at the sense input is summed with a sample of the field generator signal that has been phase-shifted 90 degrees. The nulling pot in the controller is used to adjust the voltage level of the field generator sample to the same level as the sense input signal. Proper nulling cannot be accomplished unless the electrostatic envelope is totally undisturbed. With the voltage levels equal, the two signals, which are 180 degrees out of phase, are combined and produce a zero voltage level reference.

A person, animal, or other conductive object entering the electrostatic envelope causes a coupling change between the field and sense wires. This type disturbance will not have the same effect on both sense wires and therefore will not cancel out at the sense filter. The signal will pass through the sense filter into the controller, through the nulling circuit, and into the synchronous detector for processing. The intrusion threshold detector circuit analyzes the amplitude, rate, and duration of this signal, taking into effect the sensitivity and lower band pass settings, to determine if this activity corresponds to an intrusion type disturbance. If the detector circuit determines that the disturbance is above the preset threshold setting, the detector operates a relay producing an intrusion alarm.

The field and sense wires are terminated at a fixed capacitance for supervisory monitoring. When a wire becomes grounded, goes open, or shorts to another wire in the system, a major change to the system capacitance occurs. This change is detected by the supervision threshold detector which operates a relay producing a supervisory alarm.

The lower band-pass, which is the slow end of the detectable speed window, is jumper selectable as follows: 1.2 inches per second, 2.3 inches per second, or 0 inches per second. The upper end of the detectable speed window is factory set at 26.25 feet per second.

3.0 SYSTEM TESTING

3.1 Test Installation

Testing of earlier versions of E-Field in the Area III test bed took place with the sensors installed on two fences consisting of fiberglass posts installed parallel to each other and 13 feet apart. Appendix A lists factory changes made between early 600-series and present 800-series systems.

The original plan for testing the series EF-800 sensor called for the sensor to be installed on existing fiberglass posts. Because the use of fiberglass posts would not be in accordance with the factory installation procedure, it was decided to remove the east set of fiberglass posts and replace them with steel posts, purchase a second sensor, and install it on the steel posts. The original sensor was installed on the existing west fence of fiberglass posts to obtain comparison data (Figure 3).



Figure 3. The Two Sensors Installed in the Area III Test Field

The following three configurations were used during the evaluation of this sensor.

1. Four-wire, freestanding, 100-meter zone, with EF810 controller mounted on a steel post outside the detection field (Figure 4). The middle and end posts are made of steel, and all interim posts are made of fiberglass. All posts are set firmly in concrete. A ground wire was installed on each fiberglass post to ground each insulator (Figure 5). Appendix B includes the fiberglass post insulator grounding procedure.

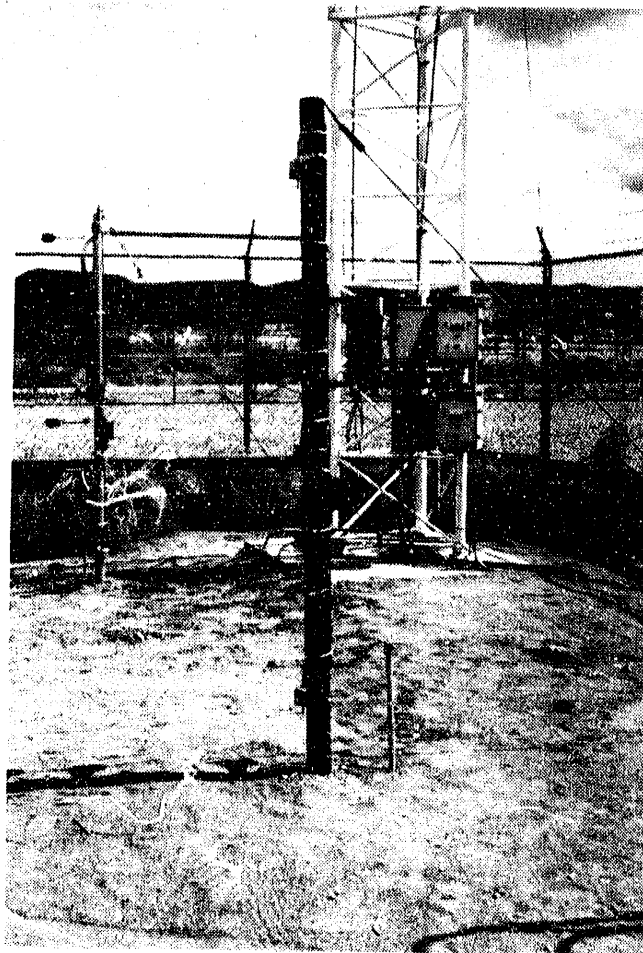

Figure 4. The Two Controllers Mounted away from the Sensor End Posts



Figure 5. Grounding of Insulators on Fiberglass Posts

2. Four-wire, freestanding, 100-meter zone, with controller mounted on a steel post outside the field. All posts are made of schedule 40 galvanized steel and set firmly in concrete.
3. Four-wire, freestanding, 100-meter zone, with controller mounted on a steel post outside the field. All posts are made of schedule 40 galvanized steel and set firmly in concrete. Each steel post is connected to a wire attached to a copper clad ground rod.

Configuration 2 matches Stellar's recommendation for freestanding installations.

After installing the sensors in the configuration to be tested, the sensor was calibrated using the procedure included as Appendix C.

3.2 Detection Testing

Each of the following tests was conducted for each configuration defined above at each post, midway between each pair of posts, at tension points, and where the lower wire looked abnormally high. When tests indicated the sensitivity was set either too low or too high, the sensitivity was adjusted and all tests were repeated for that configuration.

3.2.1 Normal Walk Test

The normal walk test evaluates system sensitivity. From a minimum starting distance of 10 feet, the tester walks normally toward and perpendicular to the wires at a pace of about 3 feet per second. When an alarm occurs, the distance between the test person and the wires is recorded.

The following results were recorded for the normal walk test.

- Configuration 1: When the tester walked toward a post, the average distance between the tester and the wires when the alarm sounded was 14 inches; when the tester walked toward the wires between posts, the average distance between the tester and the wires when the alarm sounded was 36 inches.
- Configuration 2: When the tester walked toward a post, the average distance between the tester and the wires when the alarm sounded was 12.5 inches; when the tester walked toward the wires between posts, the average distance between the tester and the wires when the alarm sounded was 32 inches.
- Configuration 3: When the tester walked toward a post, the average distance between the tester and the wires when the alarm sounded was 0 inches; when the tester walked toward the wires between posts, the average distance between the tester and the wires when the alarm sounded was 28 inches.

3.2.2 Shuffle Walk Test

The shuffle walk test determines sensor detection patterns. From a minimum starting distance of 10 feet, the tester approaches the E-Field by shuffling toward and perpendicular to the wires at a very slow pace of approximately 2 inches per second. The test person holds his arms motionless at his sides, and stiff-legged steps are taken with both feet remaining on the ground. When an alarm occurs, the distance from the test person to the wires is recorded and the results are plotted.

The following results were recorded for the shuffle walk test. The detection pattern plots are included as Figure 6, and Appendix D contains the supporting data.

- Configuration 1: When the tester walked toward a post, the average distance between the tester and the wires when the alarm sounded was 27.5 inches; when the tester walked toward the wires between posts, the average distance between the tester and the wires when the alarm sounded was 37.6 inches.
- Configuration 2: When the tester walked toward a post, the average distance between the tester and the wires when the alarm sounded was 8.6 inches; when the tester walked toward the wires between posts, the average distance between the tester and the wires when the alarm sounded was 33.1 inches.

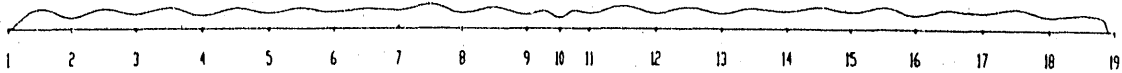

Sensor Mounted on Fiber Glass Posts with Grounded Insulators

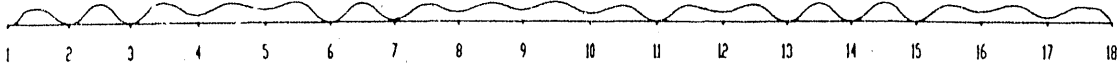

Sensor Mounted on Ungrounded Steel Posts

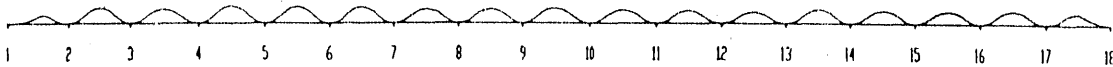

Sensor Mounted on Grounded Steel Posts

Figure 6. E-Field Detection Pattern Plots

- Configuration 3: When the tester walked toward a post, the average distance between the tester and the wires when the alarm sounded was 0 inches; when the tester walked toward the wires between posts, the average distance between the tester and the wires when the alarm sounded was 25.4 inches.

3.2.3 Climb-Through Test

The climb-through test evaluates slow penetration detection capability. From a minimum starting distance of 10 feet, at a randomly selected point, the tester approaches the wires stealthily and attempts to penetrate the E-Field by stepping or crawling between the wires. The time to detection or successful penetration time is recorded.

The following results were recorded for the climb-through test.

- Configuration 1: Five attempts were made, with detection each time. The average time from beginning to detection was 24 seconds. A successful penetration required 2 minutes and 35 seconds and the aid of the front panel meter to indicate when the test person was near detection.
- Configuration 2: Five attempts were made, with detection each time. The average time from beginning to detection was 21 seconds. A successful penetration required 2 minutes and 45 seconds and the aid of the front panel meter.
- Configuration 3: Five attempts were made, with detection each time. The average time from beginning to detection was 22 seconds. A successful penetration required 2 minutes and 50 seconds and the aid of the front panel meter.

3.2.4 Jump-Through Test

The jump-through test evaluates fast penetration detection capability. From a minimum starting distance of 10 feet, at a randomly selected point, the tester approaches the wires running and attempts to dive or jump through the lower set of sense and field wires. To test the upper set of wires, a platform or ramp is constructed and the tester attempts penetration by running and jumping through the upper set of sense and field wires. Detection/no detection results are recorded.

The following results were recorded for the jump-through test.

- Configuration 1: Penetration was attempted at six different locations. Detection occurred each time.
- Configuration 2: Penetration was attempted at six different locations. Detection occurred each time.

- Configuration 3: Penetration was attempted at six different locations. Detection occurred each time.

3.2.5 Lower Wire Lift Test

The lower wire lift test evaluates the sensor's ability to detect movement of the lower wire. Using a nonmetallic object at least 10 feet long, the tester stands as far away from the E-Field as possible, slides the object under the wire, and slowly lifts it until an alarm occurs (Figure 7). The distance the wire was lifted and the time from beginning to detection are recorded.

The following results were recorded for the lower wire lift test.

- Configuration 1: The lower wire was lifted 1 inch in 12 seconds.
- Configuration 2: The lower wire was lifted .75 inch in 6 seconds.
- Configuration 3: The lower wire was lifted 1 inch in 12 seconds.

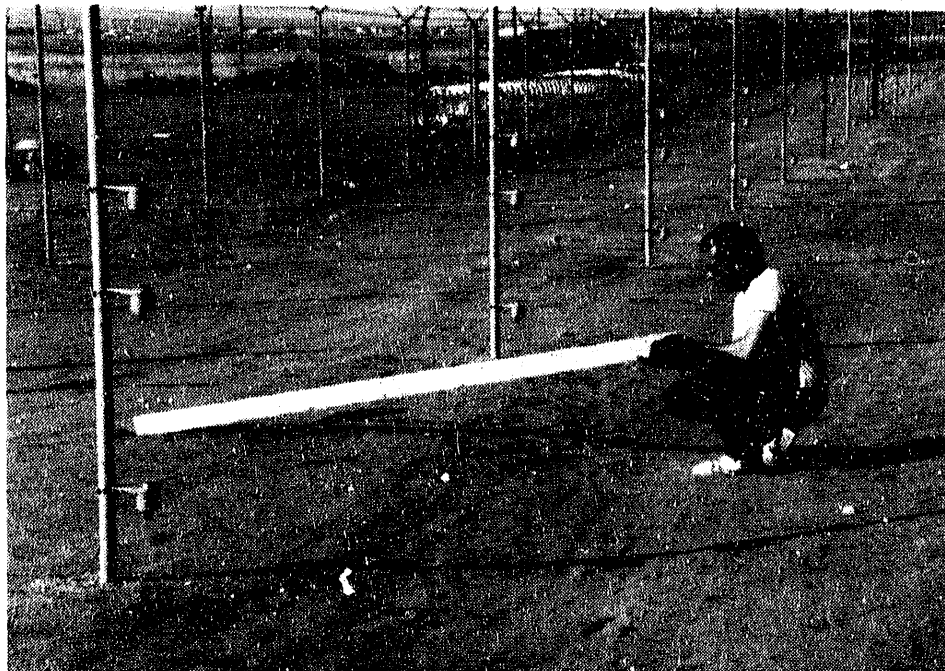

Figure 7. Lower Wire Lift Test

3.2.6 Large Target Approach Test

The large target approach test determines the effect on the sensor of a large target moving into, parallel to, and out of the detection field. The tester drives a vehicle (golf cart or larger) slowly into the detection envelope of the E-Field configuration under test. The detection/no detection results are recorded. The sensor is allowed to reset and the vehicle is slowly driven parallel to the sensor. The detection/no detection results are again recorded. The sensor is allowed to reset again, and the vehicle is driven out of the detection envelope of the sensor. The detection/no detection results of this phase are also recorded.

The following results were recorded for the large target approach test.

- Configuration 1: Moving into the field, the target was detected; moving parallel to the sensor, the target was not detected; moving out of the field, the target was detected.
- Configuration 2: Moving into the field, the target was detected; moving parallel to the sensor, the target was not detected; moving out of the field, the target was not detected.
- Configuration 3: Moving into the field, the target was detected; moving parallel to the sensor, the target was not detected; moving out of field, the target was not detected.

Indications are that an object entering the field will be detected, but if it stays in the field it will be absorbed into the field. When the object exits the field, it changes the coupling enough to be detected again. Therefore, a slow moving intruder will probably produce two alarms.

3.2.7 Small Target Approach Test

The small target approach test determines the effect on the sensor of a small target approaching the sensor. A plastic milk container filled with water is placed at least 10 feet away from the E-Field. A rope is attached to the container and passed under the lower wire of the E-Field. From a point at least 10 feet away from the wires and on the side of the E-Field opposite where the milk container was placed, a tester pulls the rope and container toward and then under the lower sense wire at a very slow pace of approximately 2 inches per second. The distance of the container from the wires when an alarm occurs is recorded. Repeat this procedure using two, three, and four containers.

The following results were recorded for the small target approach test.

- Configuration 1: One container--no detection; two containers--no detection, three containers--detection when the containers had passed 4 inches under the wire; four containers--detection when the containers had passed 4 inches under the wire.

- Configuration 2: One container--no detection; two containers--no detection; three containers--detection when the containers had passed 4 inches under the wire; four containers--detection when the containers had passed 4 inches under the wire.
- Configuration 3: One container--no detection; two containers--no detection; three containers--detection when the containers had passed 4 inches under the wire; four containers--detection when the containers had passed 4 inches under the wire.

3.2.8 Changing Ground Potential Tests

The changing ground potential tests determine if rain causes nuisance alarms by changing the ground potential of the posts and insulators.

A post is selected at random and the insulators, the post, and the concrete base are sprayed with water using a garden type sprayer. The alarm/no alarm results are recorded.

The following results were recorded for the changing ground potential test.

- Configuration 1: no alarm.
- Configuration 2: no alarm.
- Configuration 3: no alarm.

During one of the sessions for this test a small twig was noticed hanging from the lower wire to ground on the fence in Configuration 1. A fine mist was sprayed at the twig. As soon as the mist struck the twig, an alarm sounded. The same test was attempted on each configuration with the same result. This indicates that care must be exercised to keep weeds and debris away from the lower wire.

3.2.9 Water Runoff Tests

Water runoff tests determine if water running through the detection area causes nuisance alarms.

A water truck was used to flood a small area of the E-Field configuration under test to simulate a heavy rainfall. The alarm/no alarm results were recorded as follows.

- Configuration 1: no detection.
- Configuration 2: no detection.
- Configuration 3: no detection.

3.2.10 Field Strength Pattern Plots

Field strength patterns were determined midway between two posts and near one of the posts for each configuration. The field strength pattern was also determined for a sensor the same as Configuration 1 but with two dummy wires installed. The results were recorded and plotted.

A 10 foot by 10 foot wooden frame was constructed out of two by four lumber and placed perpendicular to the E-Field configuration being tested with the wires in the center of the frame (Figure 8).



Figure 8. Wooden Frame Constructed for Measuring Field Strength Patterns

A two by four board 11 feet long with one 1/4-inch hole drilled every 12 inches along its entire length was attached to the frame at ground level parallel to the ground. A piece of coax was prepared with the outer braid removed for 2 inches at one end and a BNC type connector attached to the other end. The BNC end of the coax was attached to a spectrum analyzer that was displaying the strengths in decibels of the signals present in the 9.5-to-10.0 kHz frequency band. The end of the coax that had the braid removed was inserted into one of the 1/4-inch holes drilled in the 11 foot two by four (Figure 9).

The decibel level of the signal was recorded and the coax was moved to the next hole and the procedure repeated. The coax was moved from hole to hole until all eleven signal strengths were recorded at ground level then the two by four was moved up 12 inches. All levels were recorded for that height and so on until all eleven decibel levels were measured at all eleven heights (Figure 10). Measurements were taken for each of the seven configurations listed below, and the results were plotted using AutoCAD.

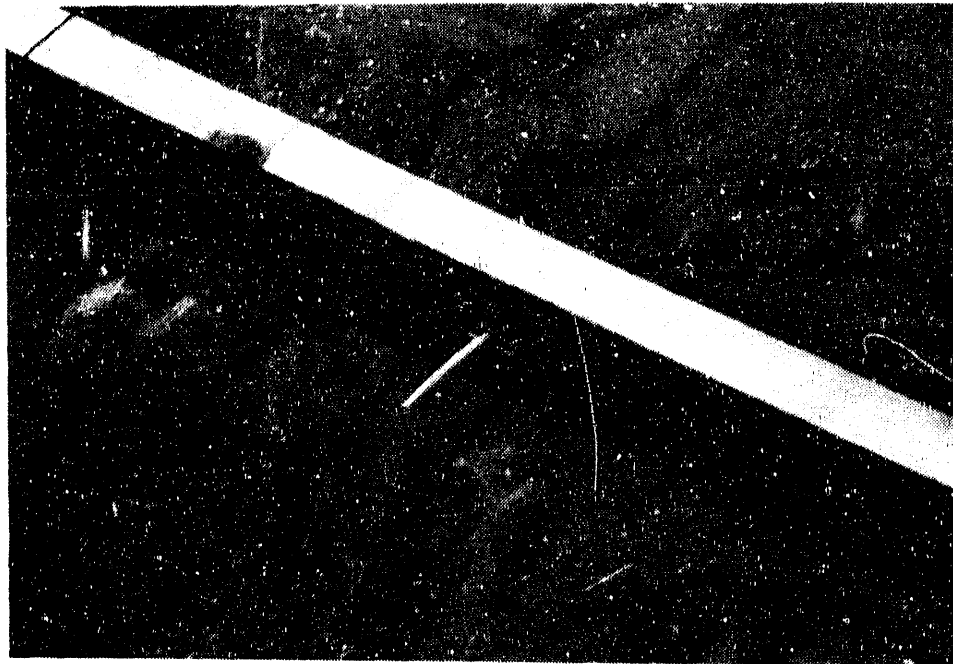

Figure 9. Two by Four on the Ground with the Bared Coax Inserted in a Pre-drilled Hole

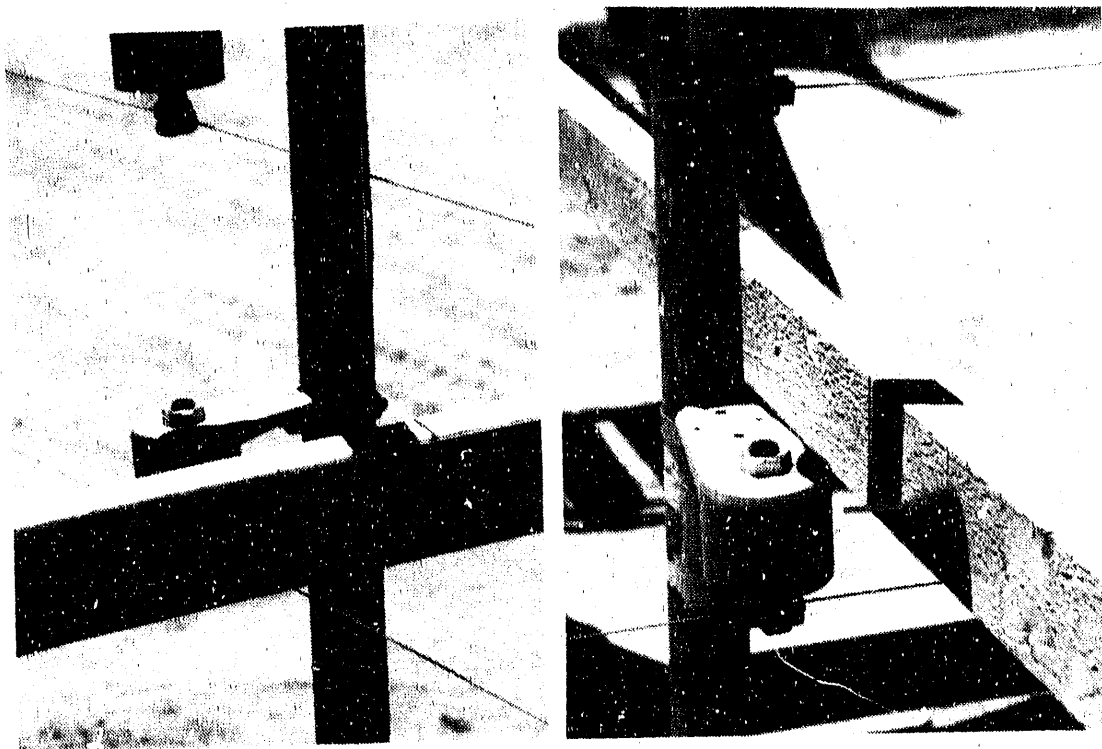

Figure 10. Two Views of Coax in Place for Measurement to be Taken near a Post

- Configuration 1 levels measured at a post: Figure 11 shows the decibel levels and Figures 12 and 13 show the AutoCAD plots.
- Configuration 1 levels measured between two posts: Figure 14 shows the decibel levels and Figures 15 and 16 show the AutoCAD plots.
- Configuration 2 levels measured at a post: Figure 17 shows the decibel levels and Figures 18 and 19 show the AutoCAD plots.
- Configuration 2 levels measured between two posts: Figure 20 shows the decibel levels and Figures 21 and 22 show the AutoCAD plots.
- Configuration 3 levels measured at a post: Figure 23 shows the decibel levels and Figures 24 and 25 show the AutoCAD plots.
- Configuration 3 levels measured between two posts: Figure 26 shows the decibel levels and Figures 27 and 28 show the AutoCAD plots.
- Configuration 1 (with dummy wires) levels measured between two posts: Figure 29 shows the decibel levels and Figures 30 and 31 show the AutoCAD plots.

AutoCAD supporting data for each of the above plots is too voluminous to include in this report but can be obtained from the author upon request.

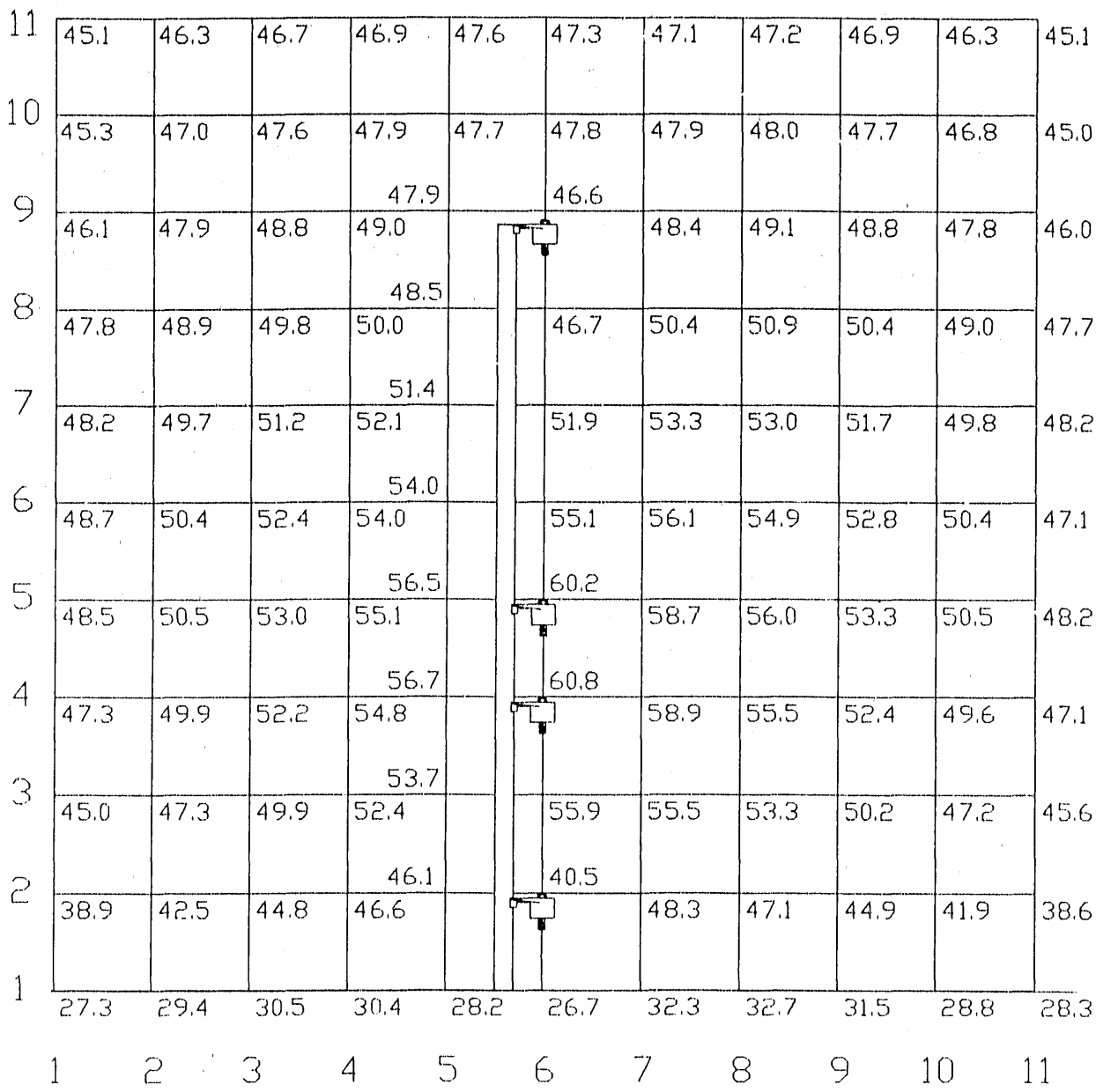

Figure 11. Field Strength Levels Measured in Decibels: Measurements Taken at Fiberglass Post

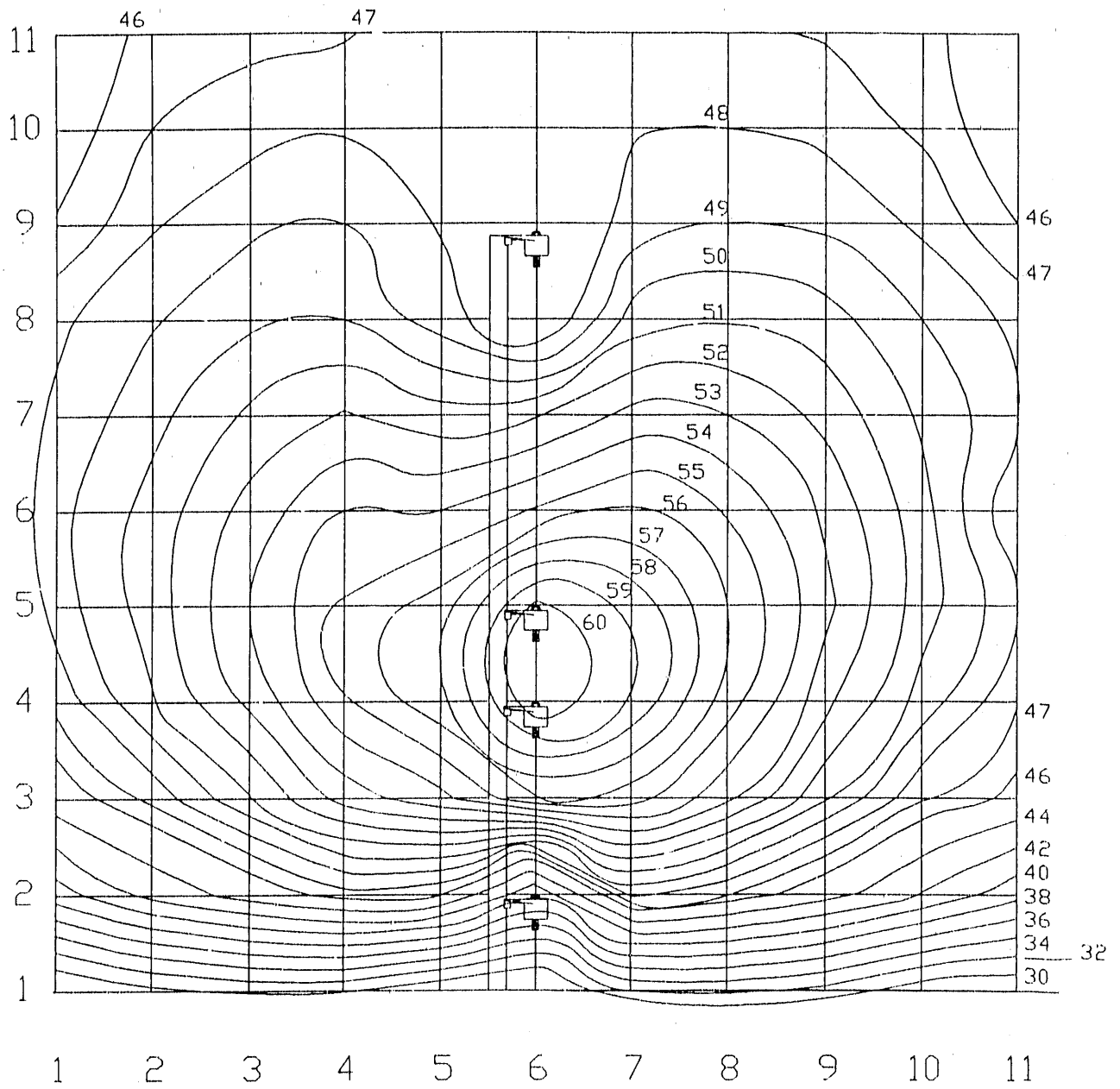

Figure 12. Field Strength Plot Shown with 1-Foot by 1-Foot Grid;
Measurements Taken at Fiberglass Post

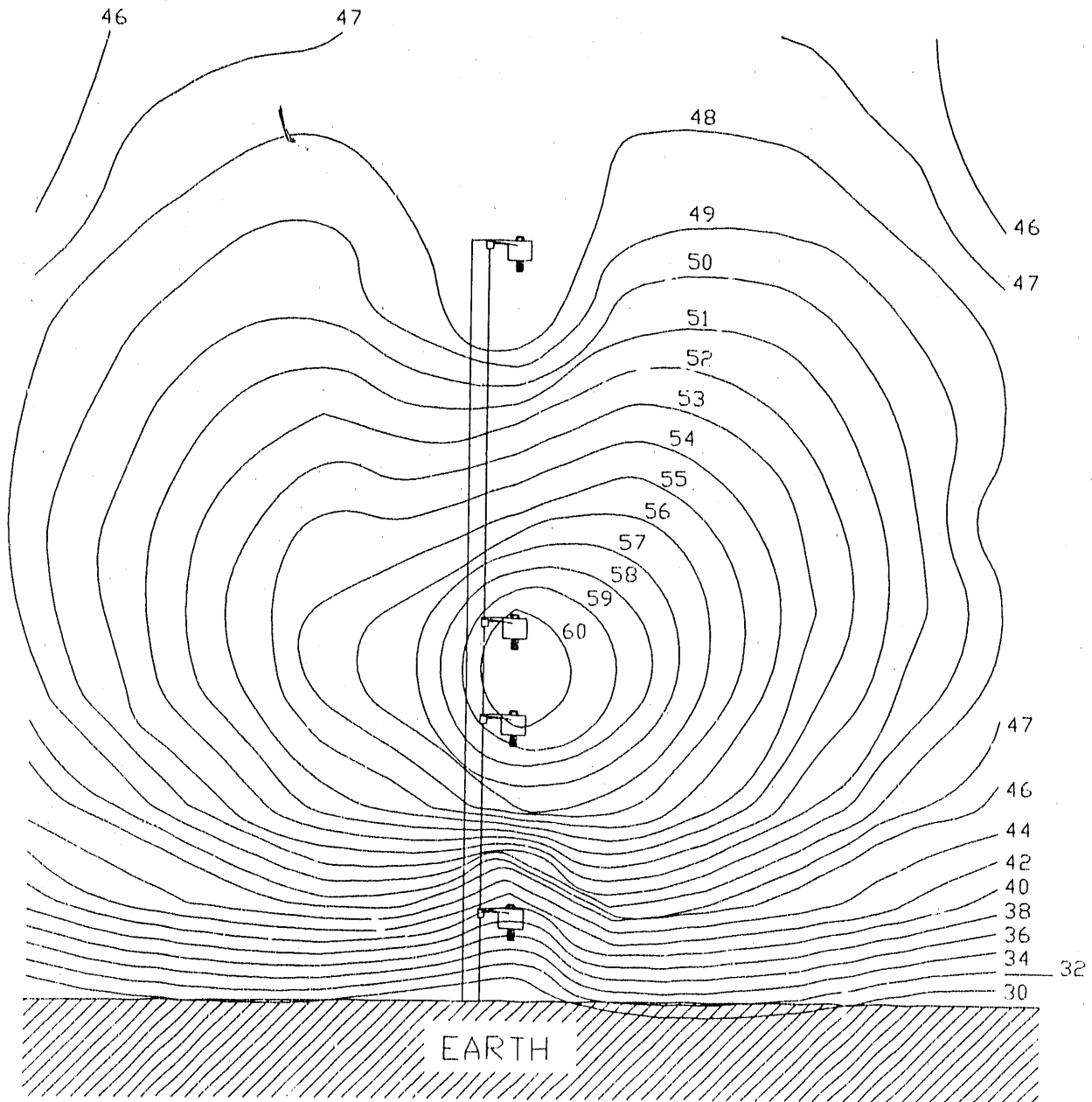

Figure 13. Field Strength Plot Shown without 1-Foot by 1-Foot Grid:
Measurements Taken at Fiberglass Post

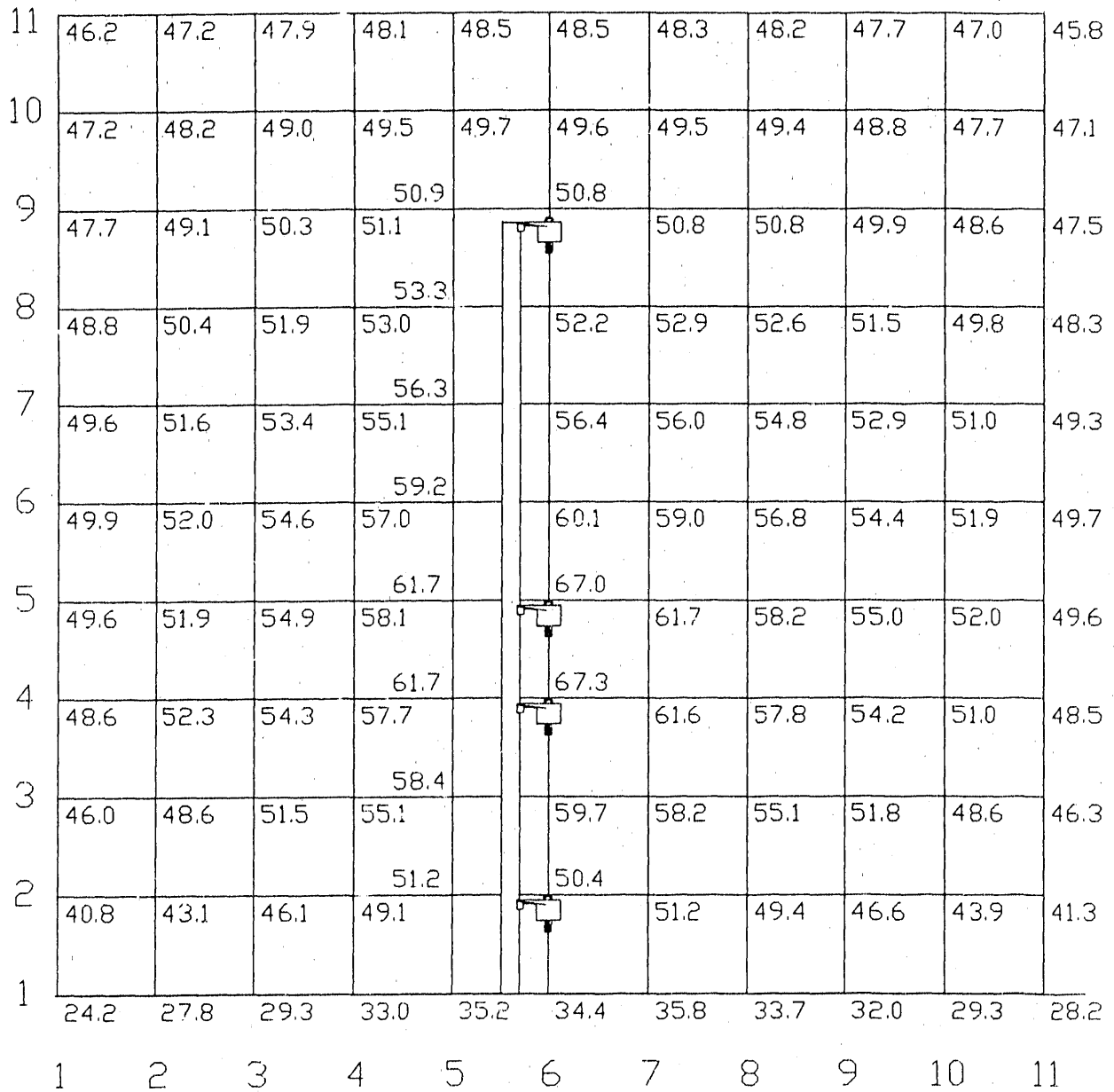

Figure 14. Field Strength Levels Measured in Decibels: Measurements Taken between Two Fiberglass Posts

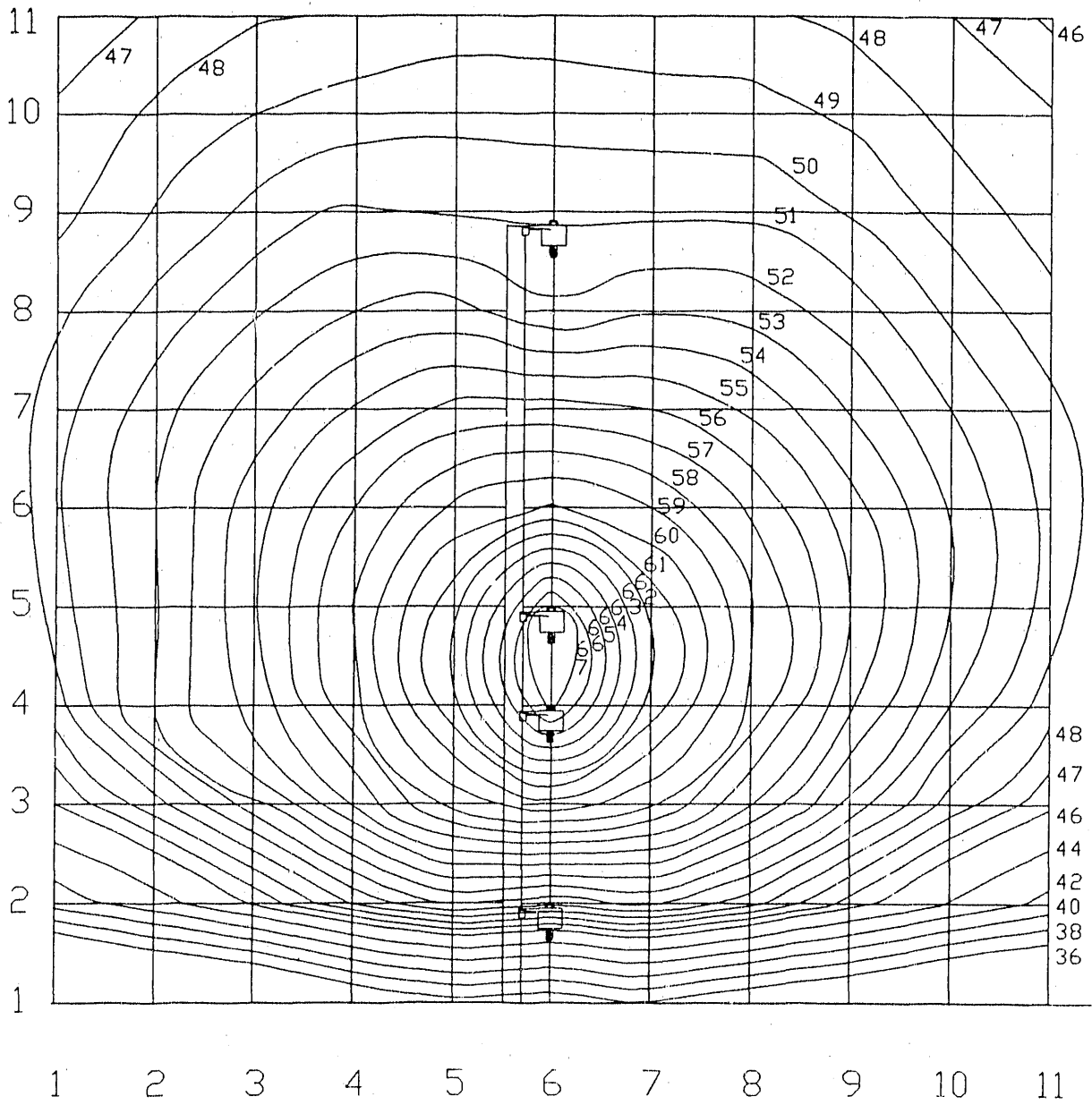

Figure 15. Field Strength Plot Shown with 1-Foot by 1-Foot Grid:
Measurements Taken between Two Fiberglass Posts

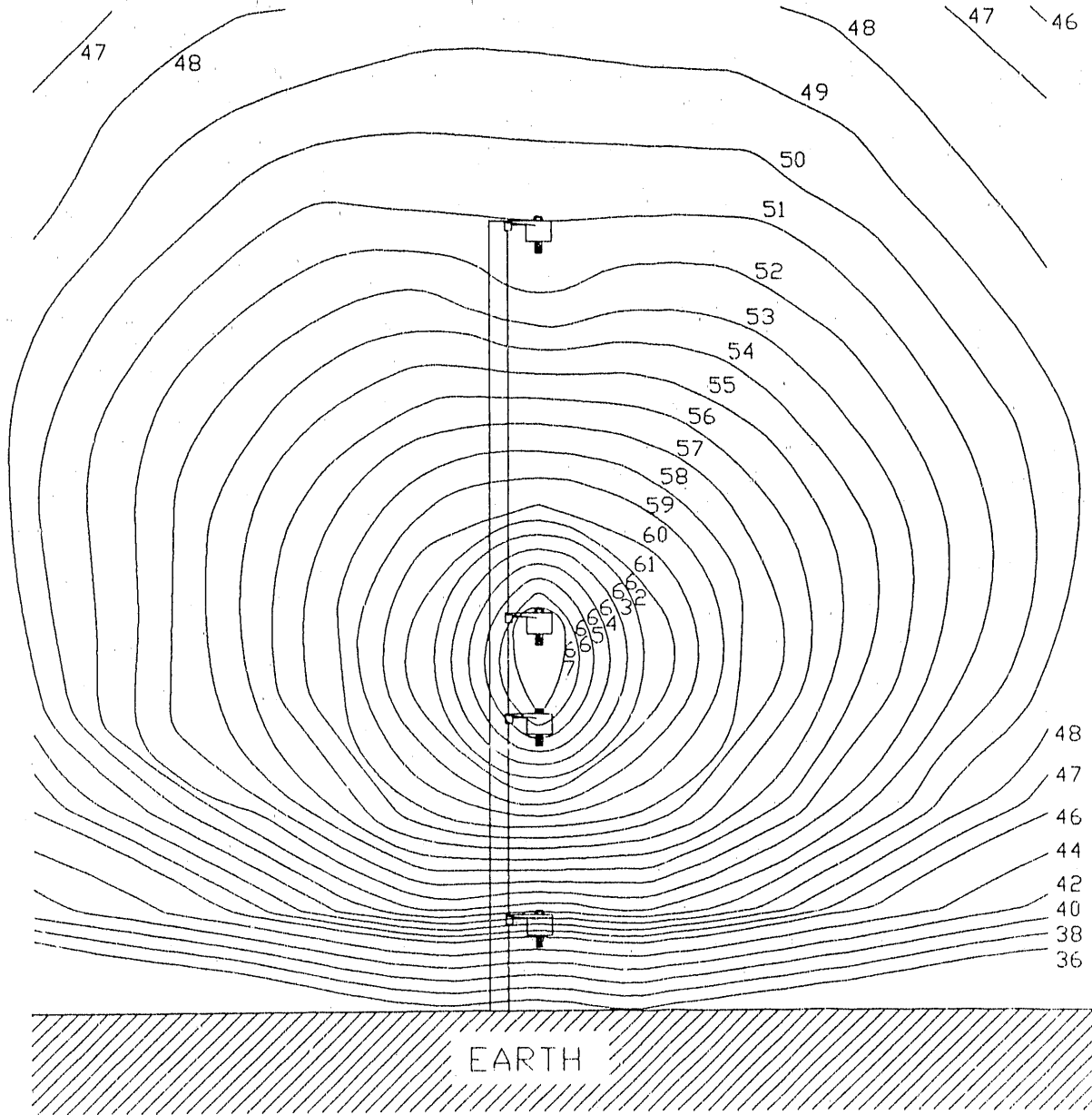

Figure 16. Field Strength Plot Shown without 1-Foot by 1-Foot Grid:
Measurements Taken between Two Fiberglass Posts

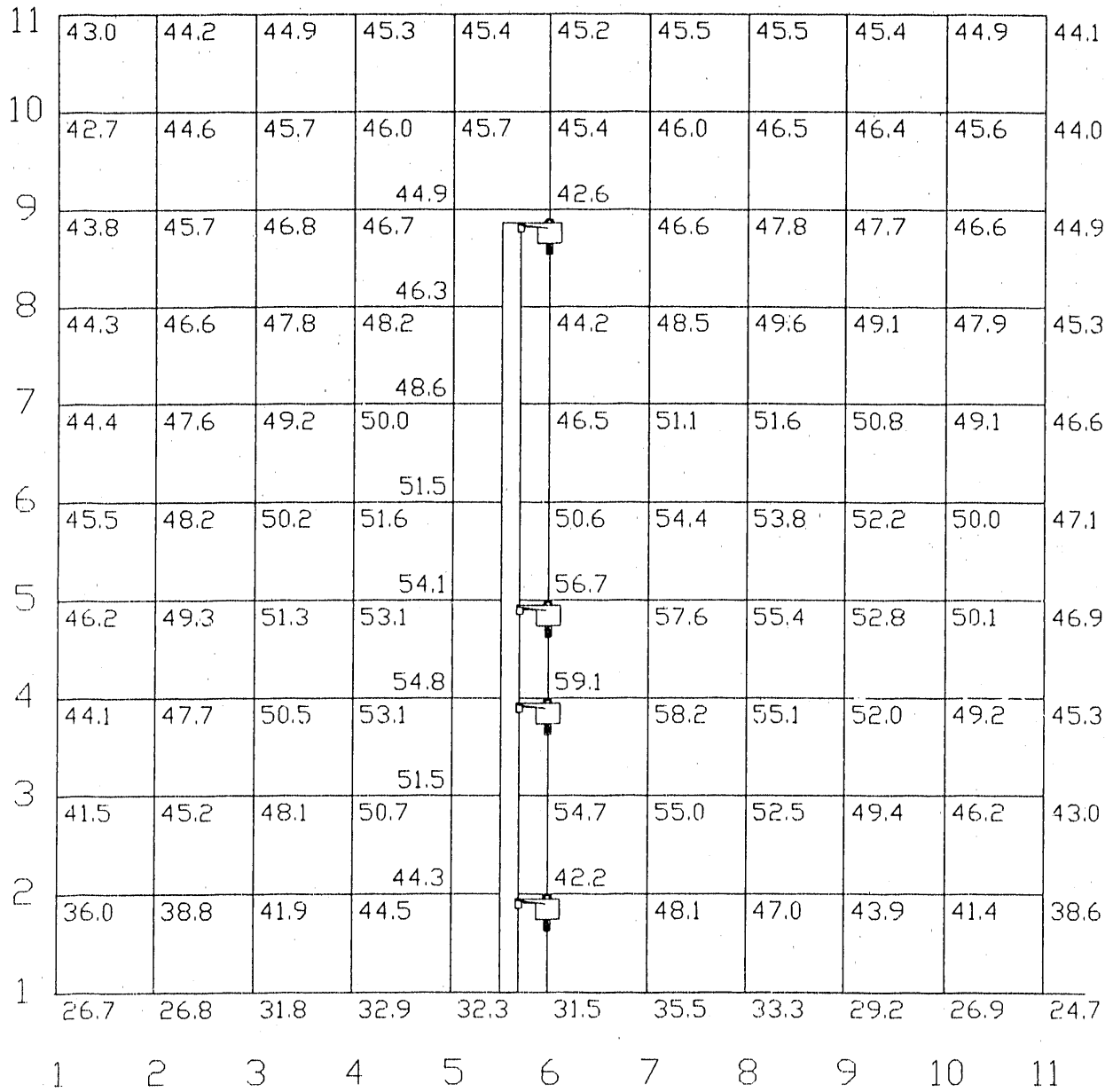

Figure 17. Field Strength Levels Measured in Decibels: Measurements Taken at Ungrounded Steel Post

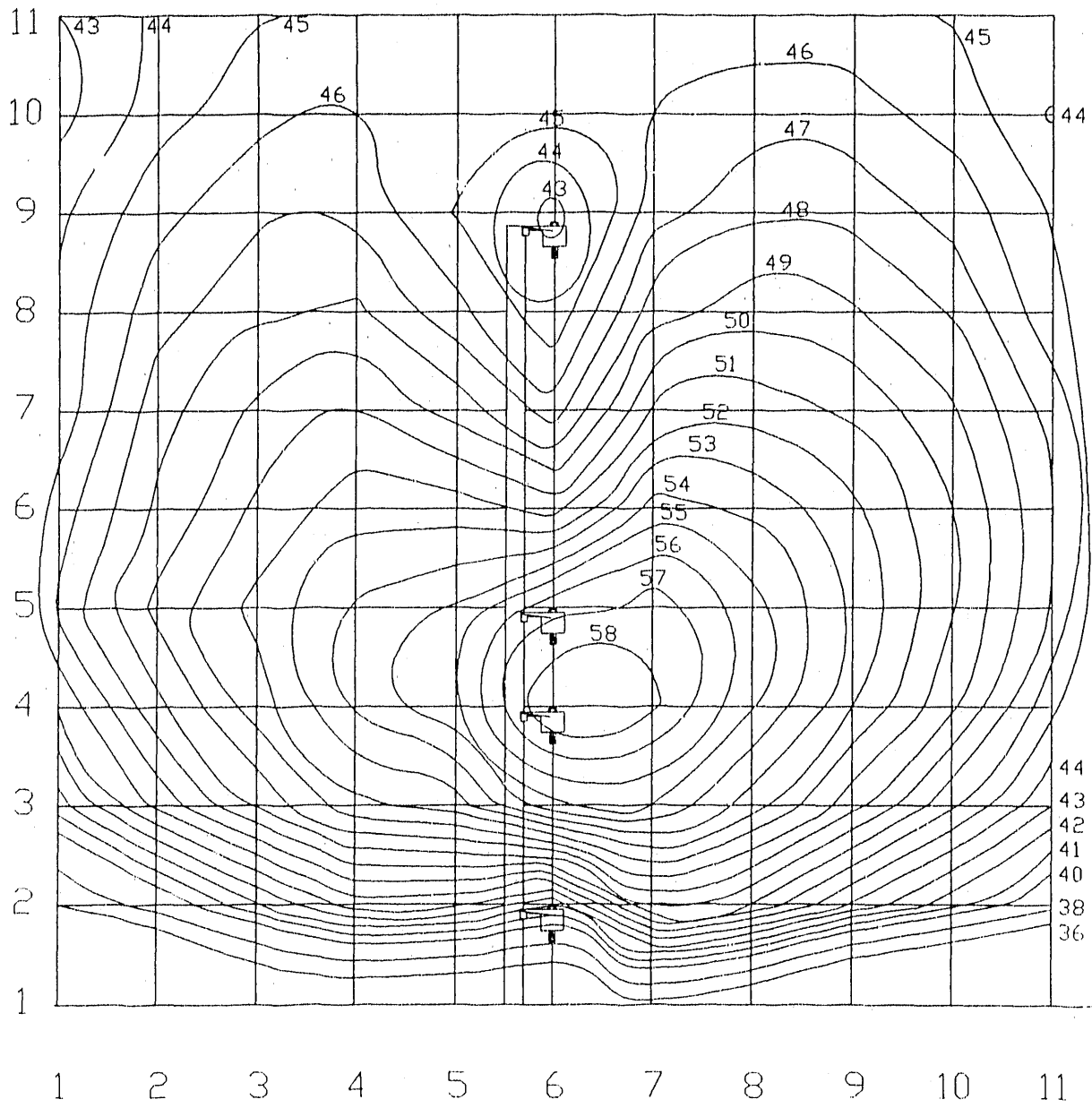

Figure 18. Field Strength Plot Shown with 1-Foot by 1-Foot Grid:
Measurements Taken at Ungrounded Steel Post

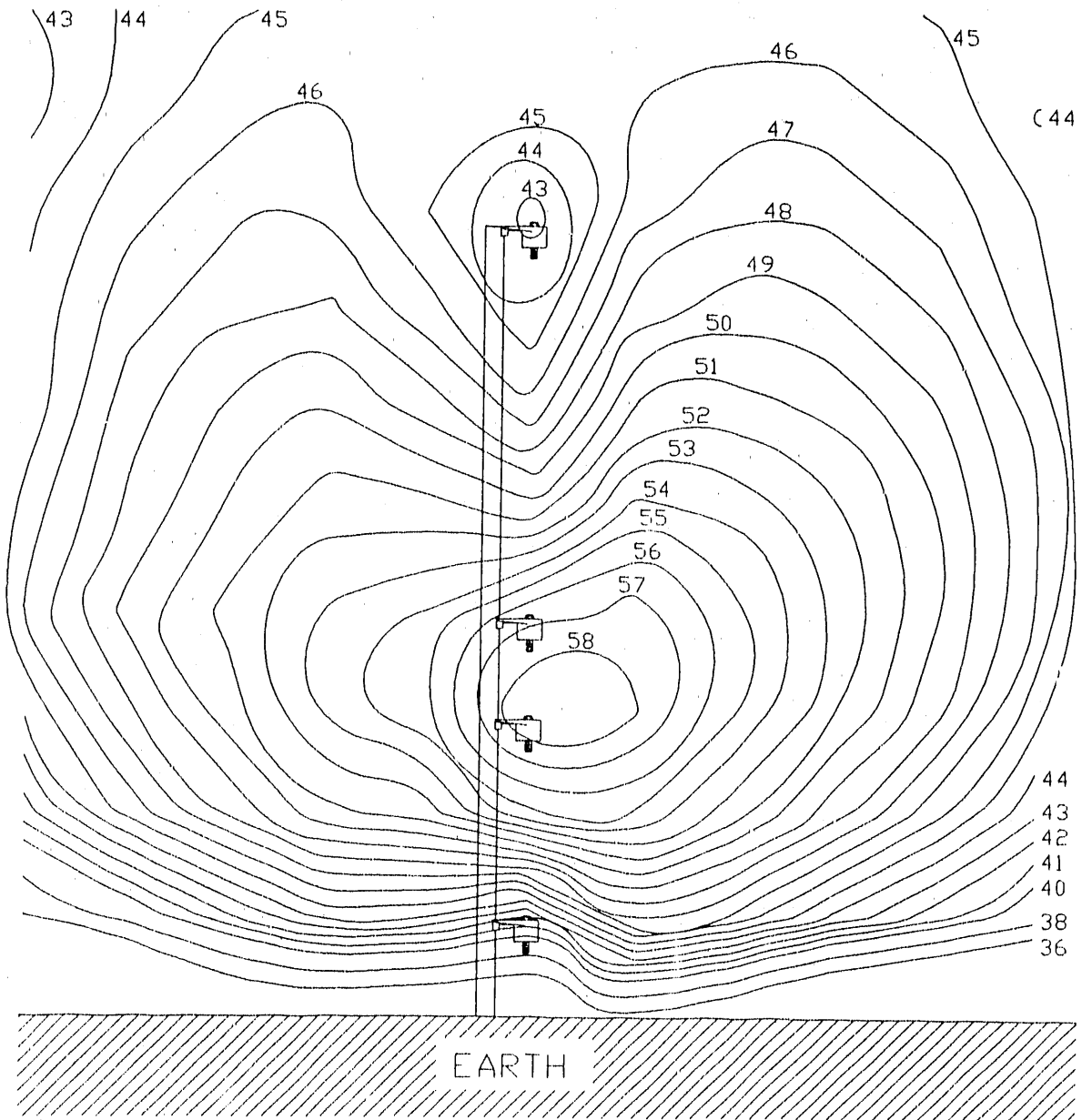

Figure 19. Field Strength Plot Shown without 1-Foot by 1-Foot Grid: Measurements Taken at Ungrounded Steel Post

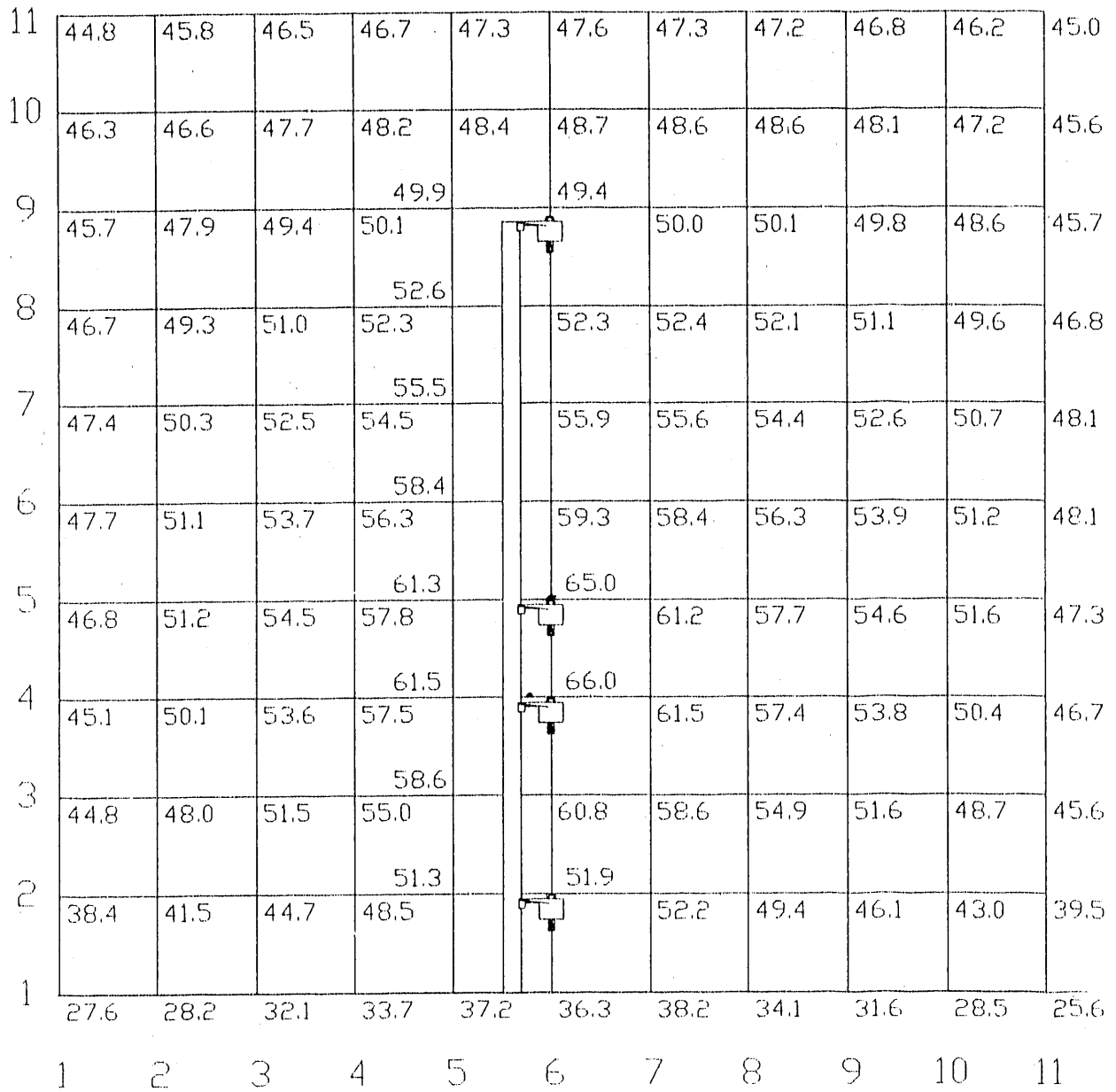

Figure 20. Field Strength Levels Measured in Decibels:
Measurements Taken between Two Ungrounded Steel Posts

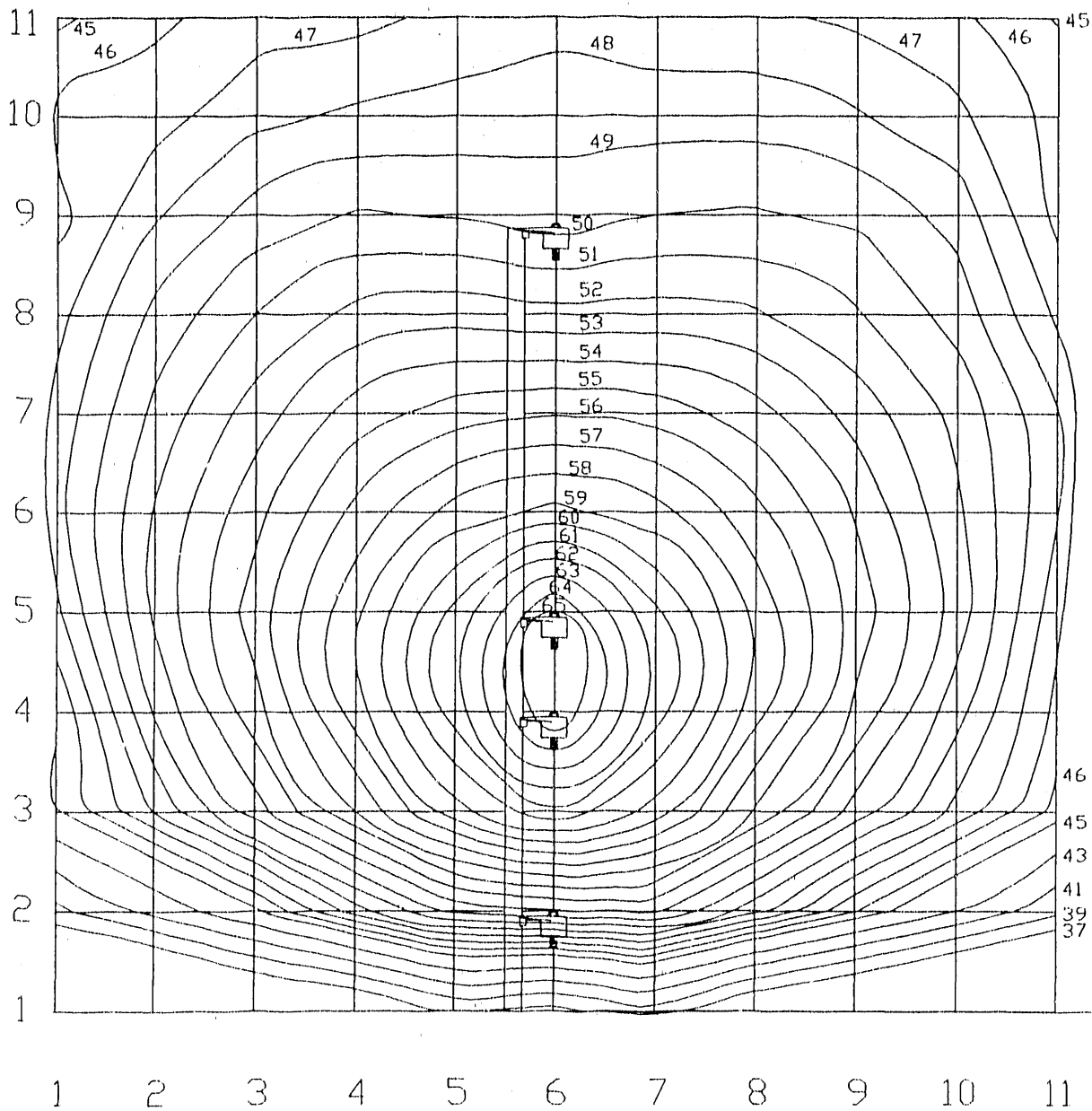

Figure 21. Field Strength Plot Shown with 1-Foot by 1-Foot Grid:
Measurements Taken between Two Ungrounded Steel Posts

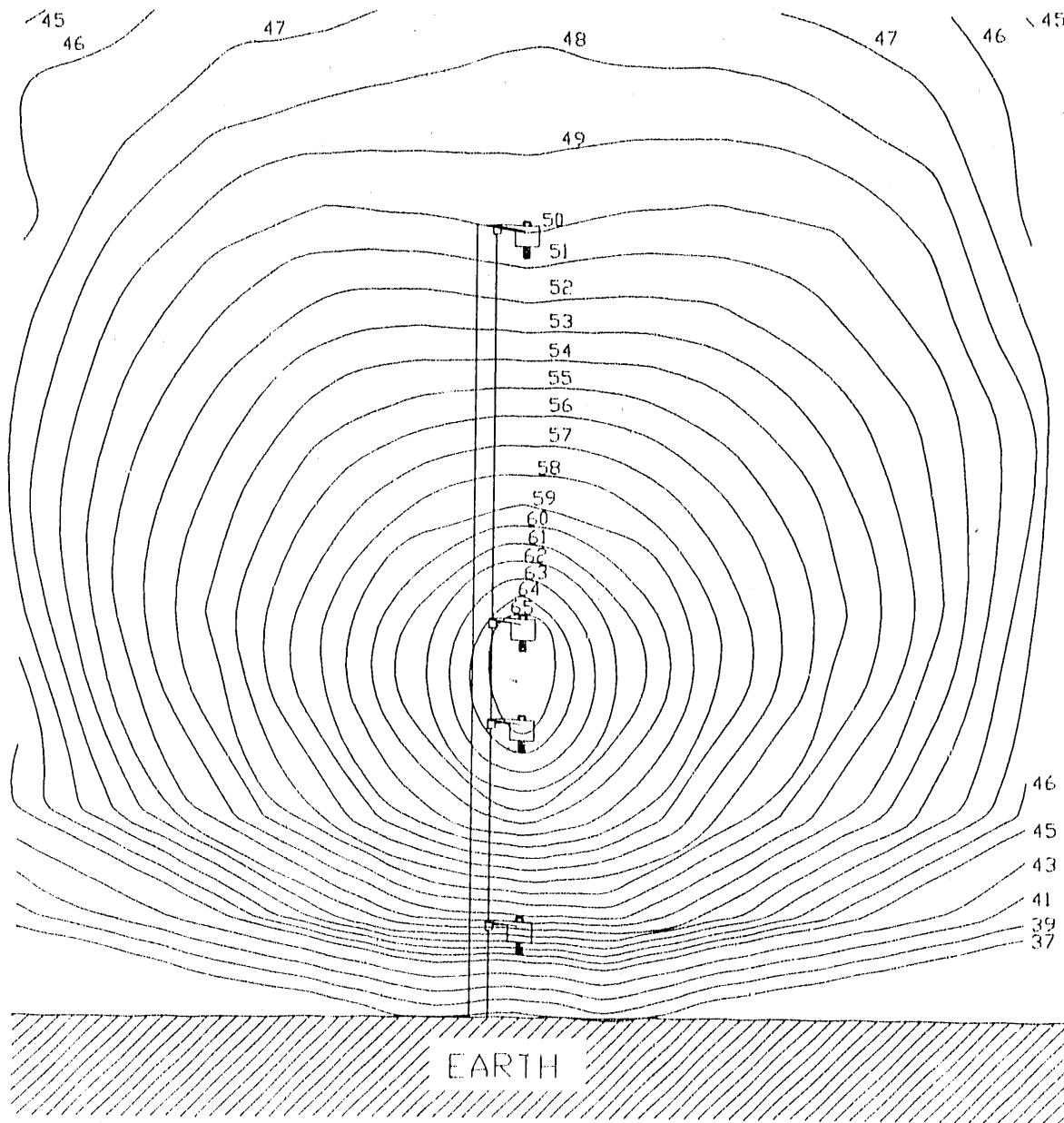

Figure 22. Field Strength Plot Shown without 1-Foot by 1-Foot Grid; Measurements Taken between Two Ungrounded Steel Posts

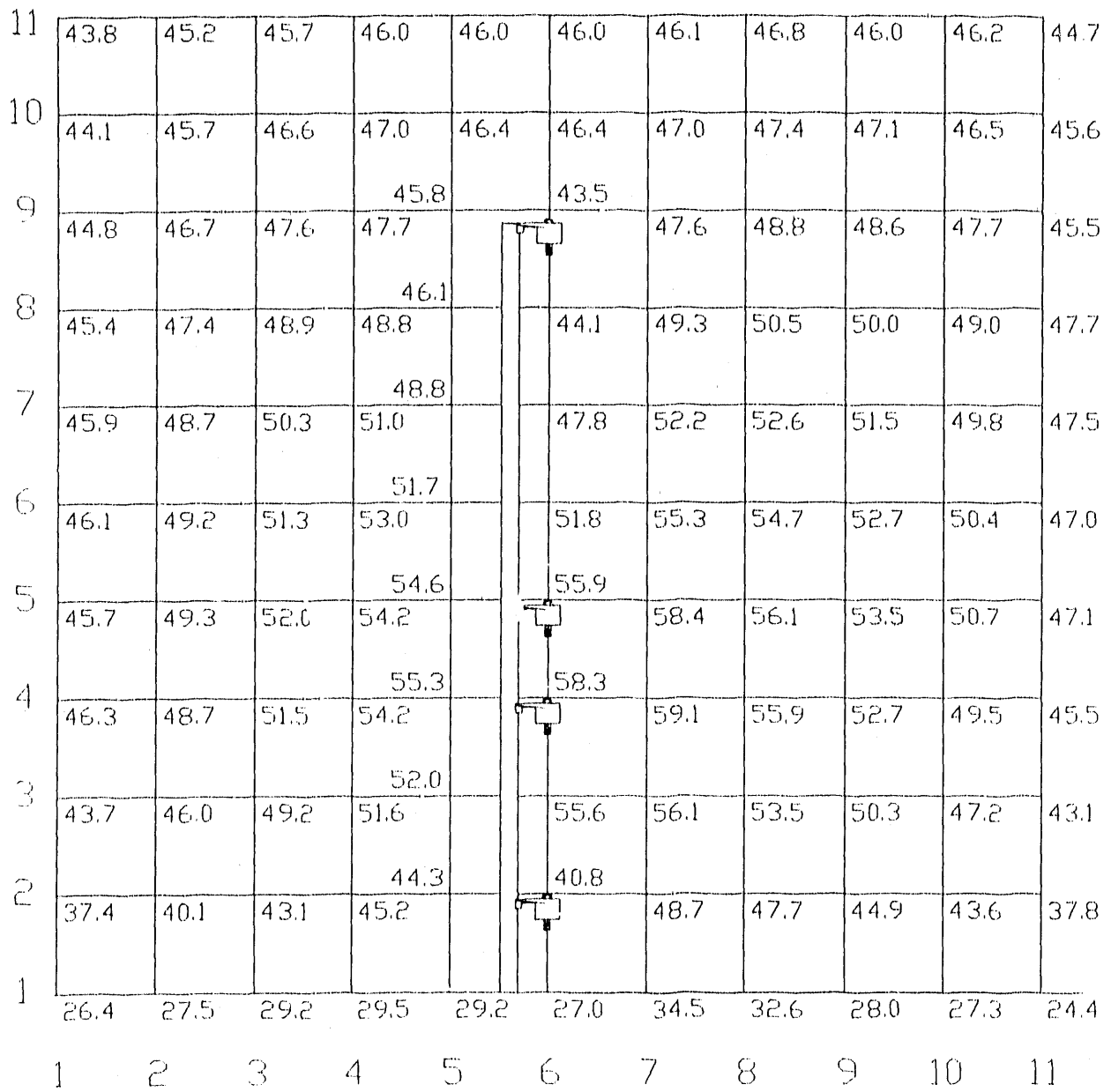

Figure 23. Field Strength Levels Measured in Decibels: Measurements Taken at Grounded Steel Post

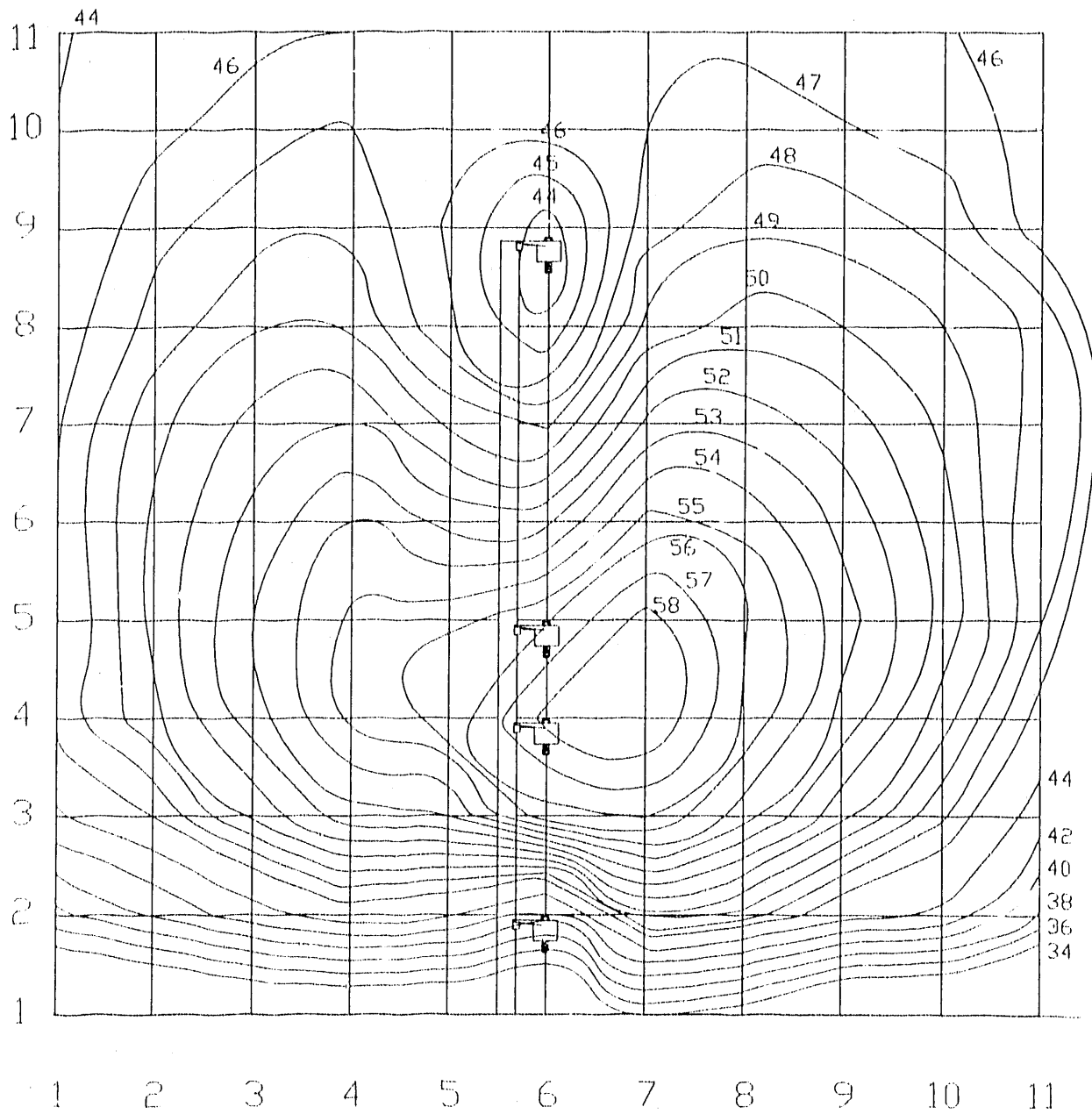

Figure 24. Field Strength Plot Shown with 1-Foot by 1-Foot Grid;
Measurements Taken at Grounded Steel Post

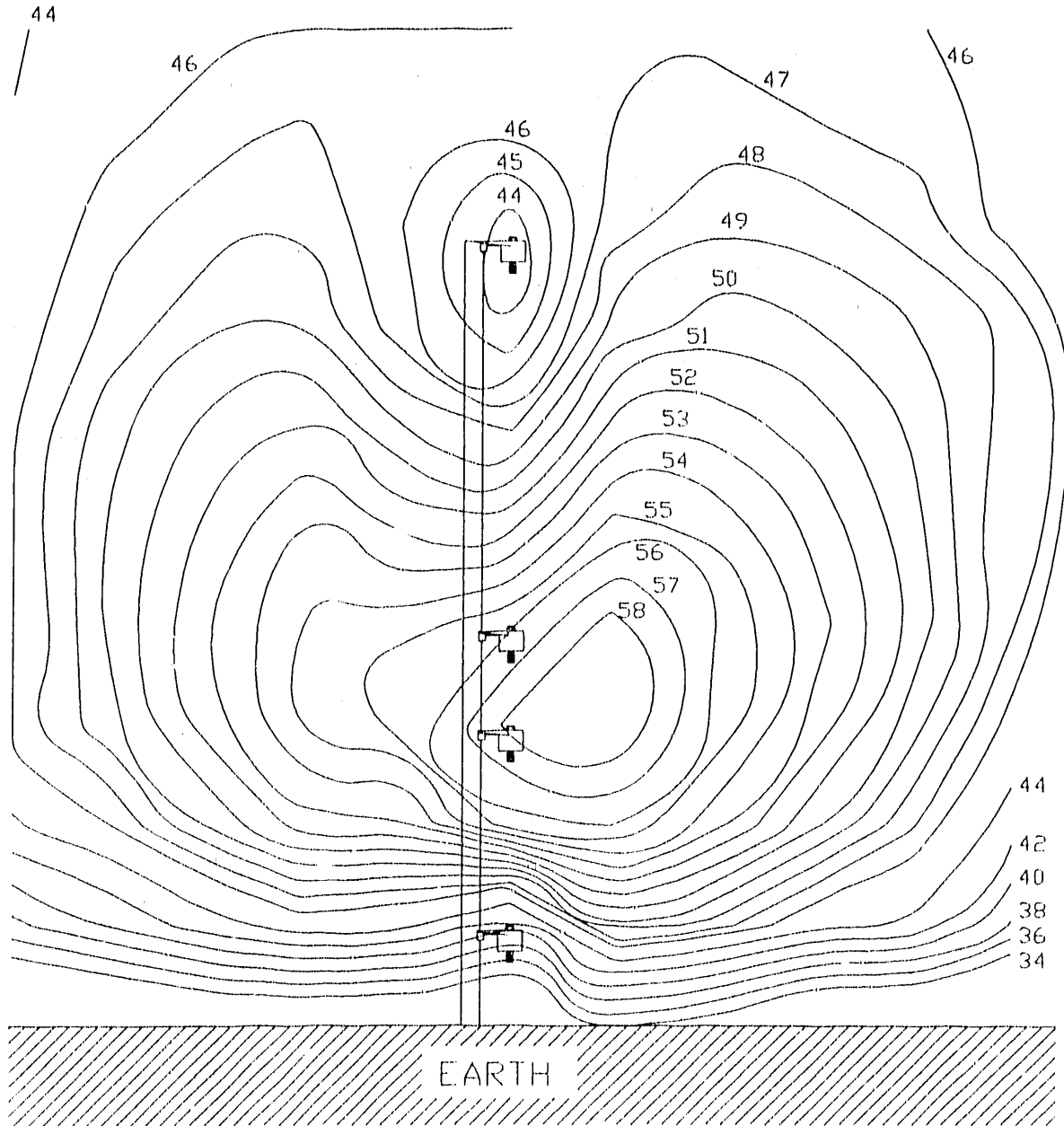

Figure 25. Field Strength Plot Shown without 1-Foot by 1-Foot Grid; Measurements Taken at Grounded Steel Post

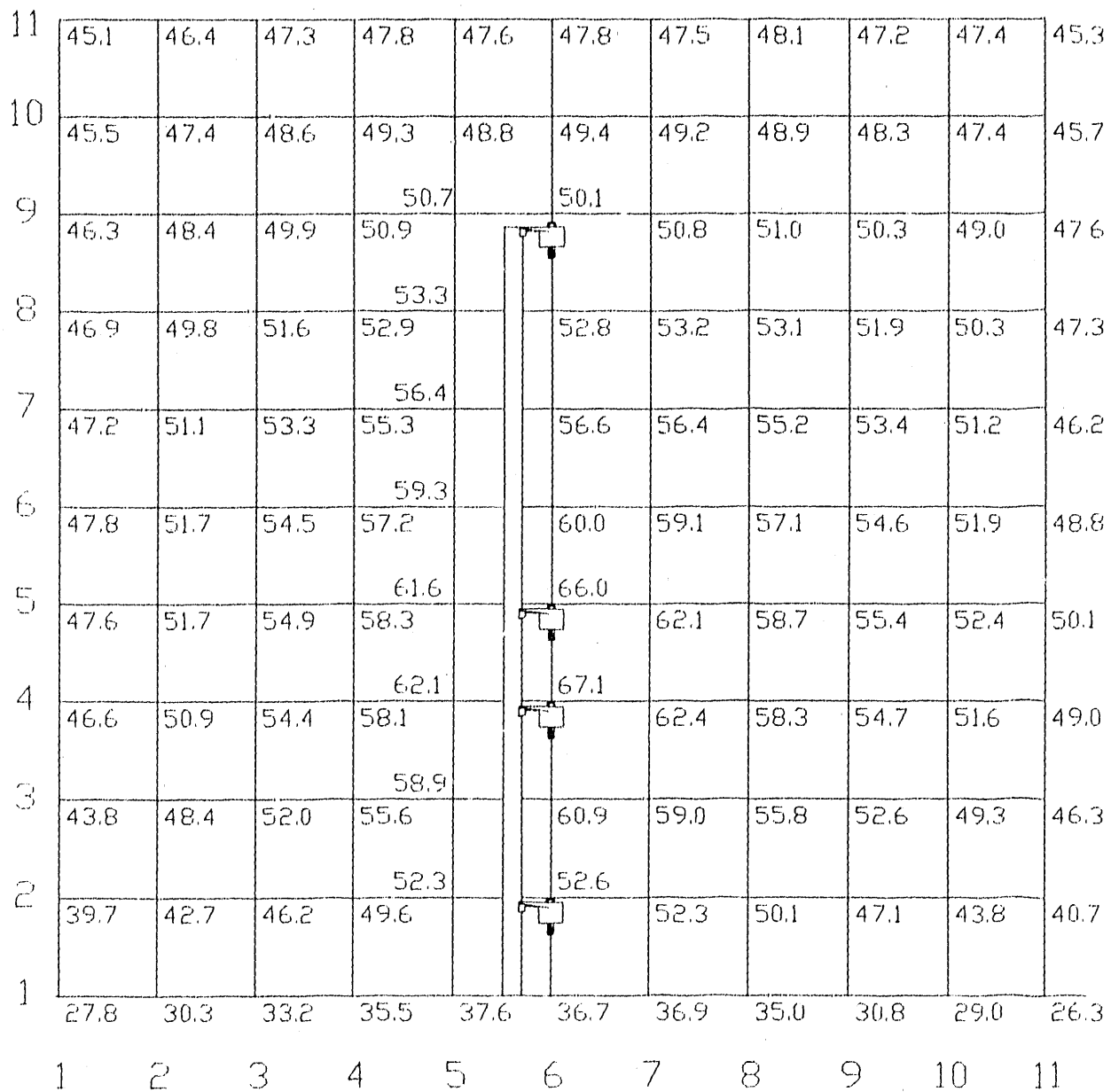

Figure 26. Field Strength Levels Measured in Decibels: Measurements Taken between Two Grounded Steel Posts

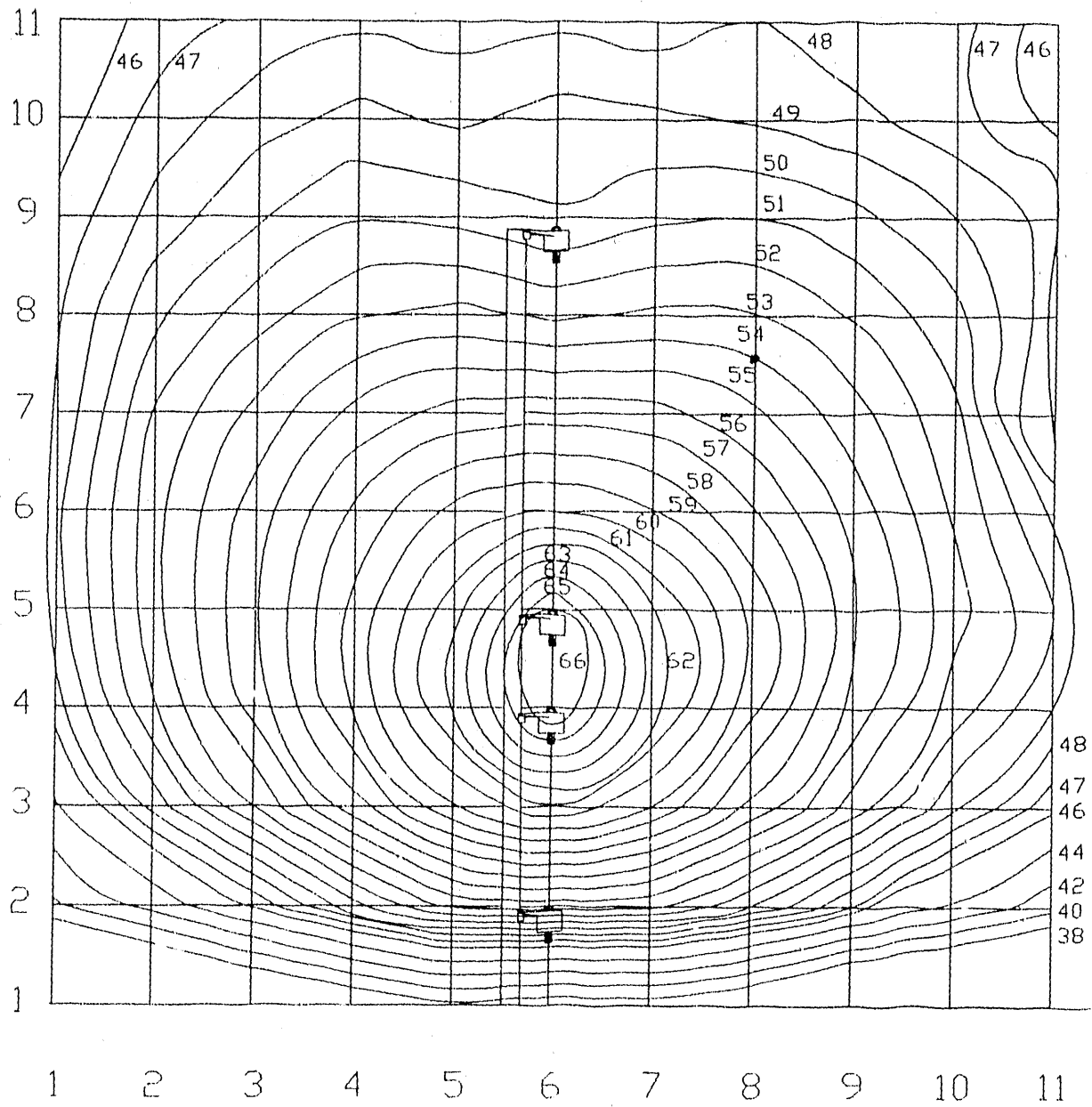

Figure 27. Field Strength Plot Shown with 1-Foot by 1-Foot Grid:
Measurements Taken between Two Grounded Steel Posts

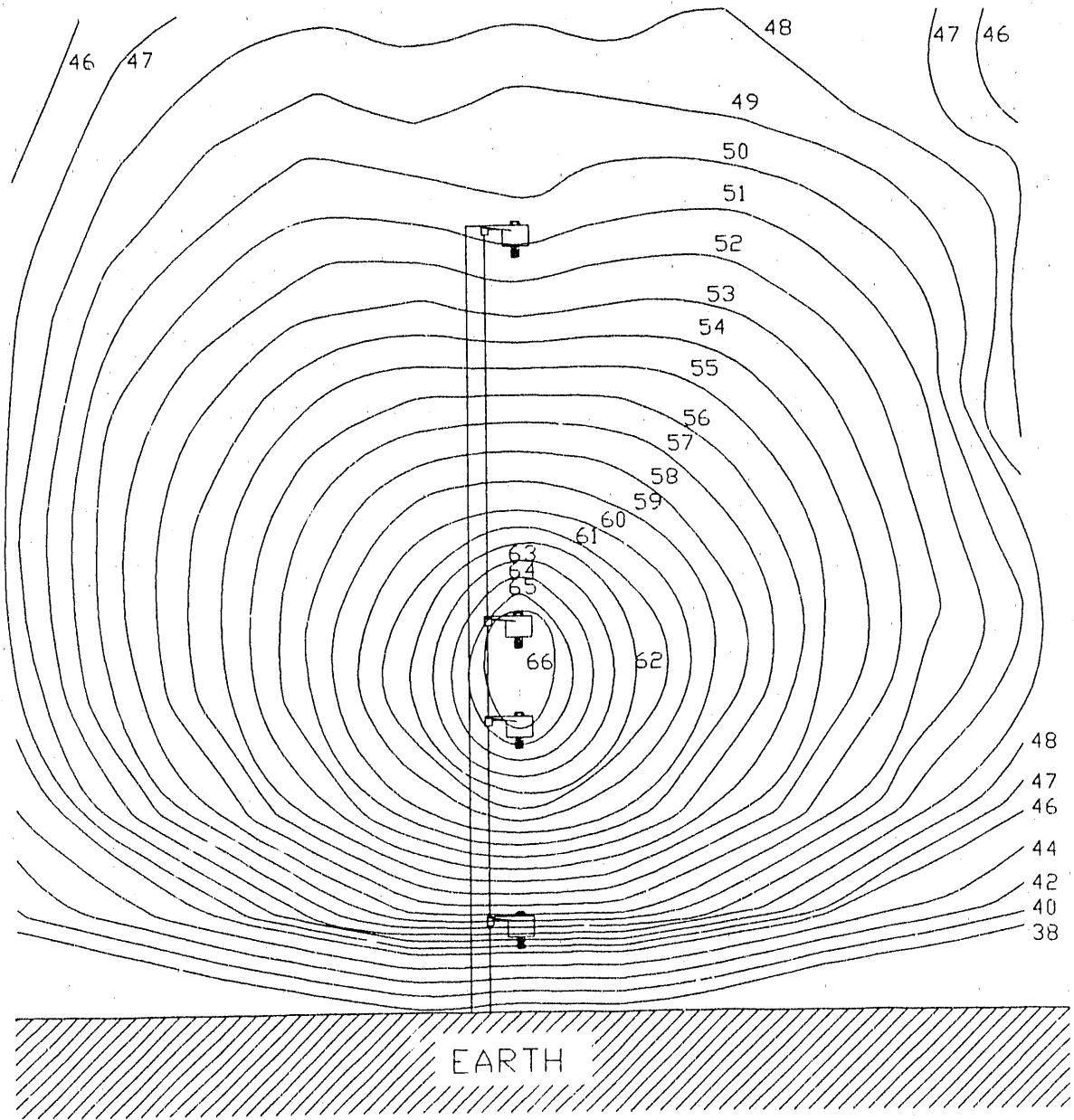

Figure 28. Field Strength Plot Shown without 1-Foot by 1-Foot Grid:
Measurements Taken between Two Grounded Steel Posts

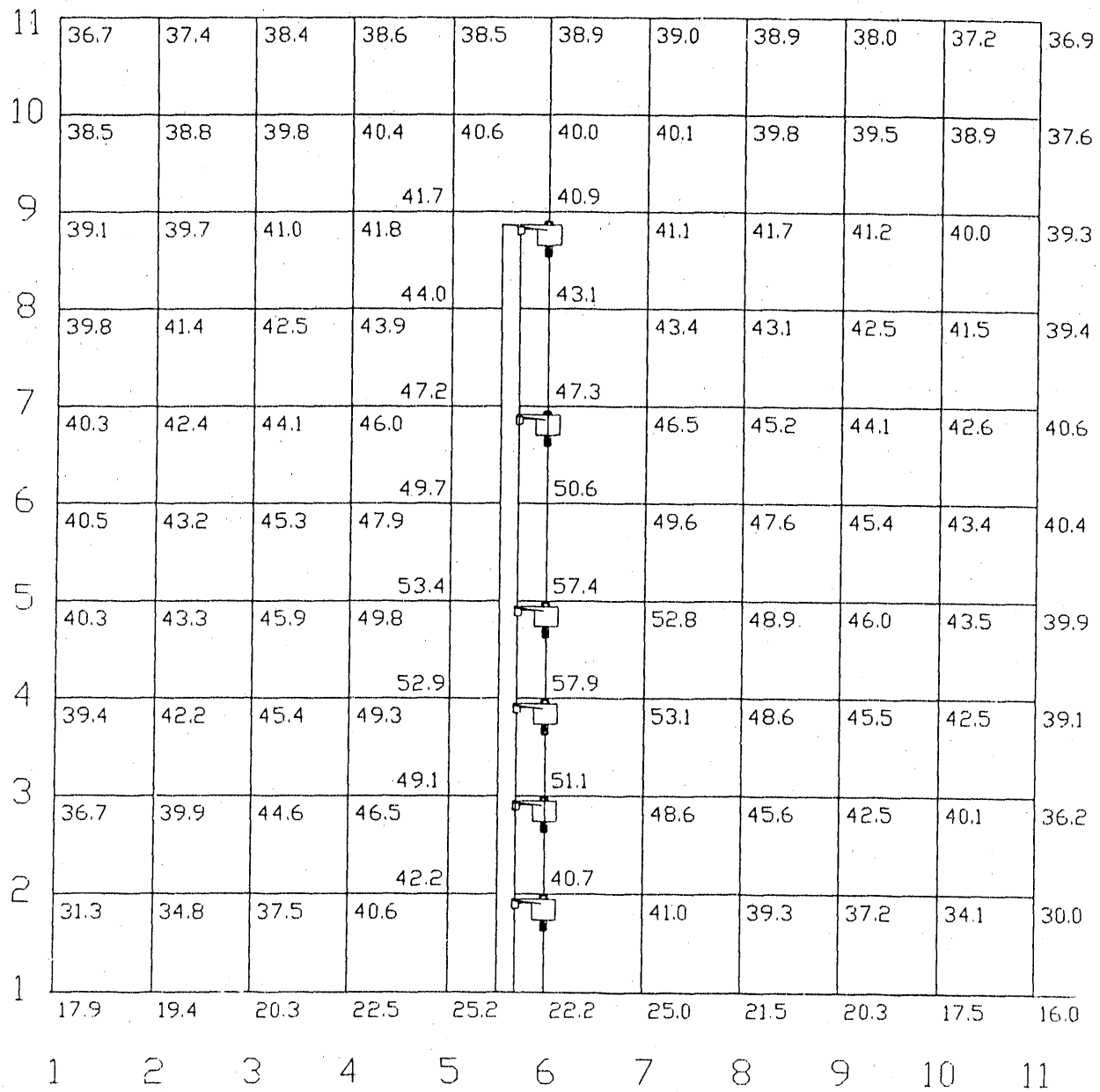

Figure 29. Field Strength Levels Measured in Decibels: Measurements Taken between Two Fiberglass Posts with Dummy Wires Installed

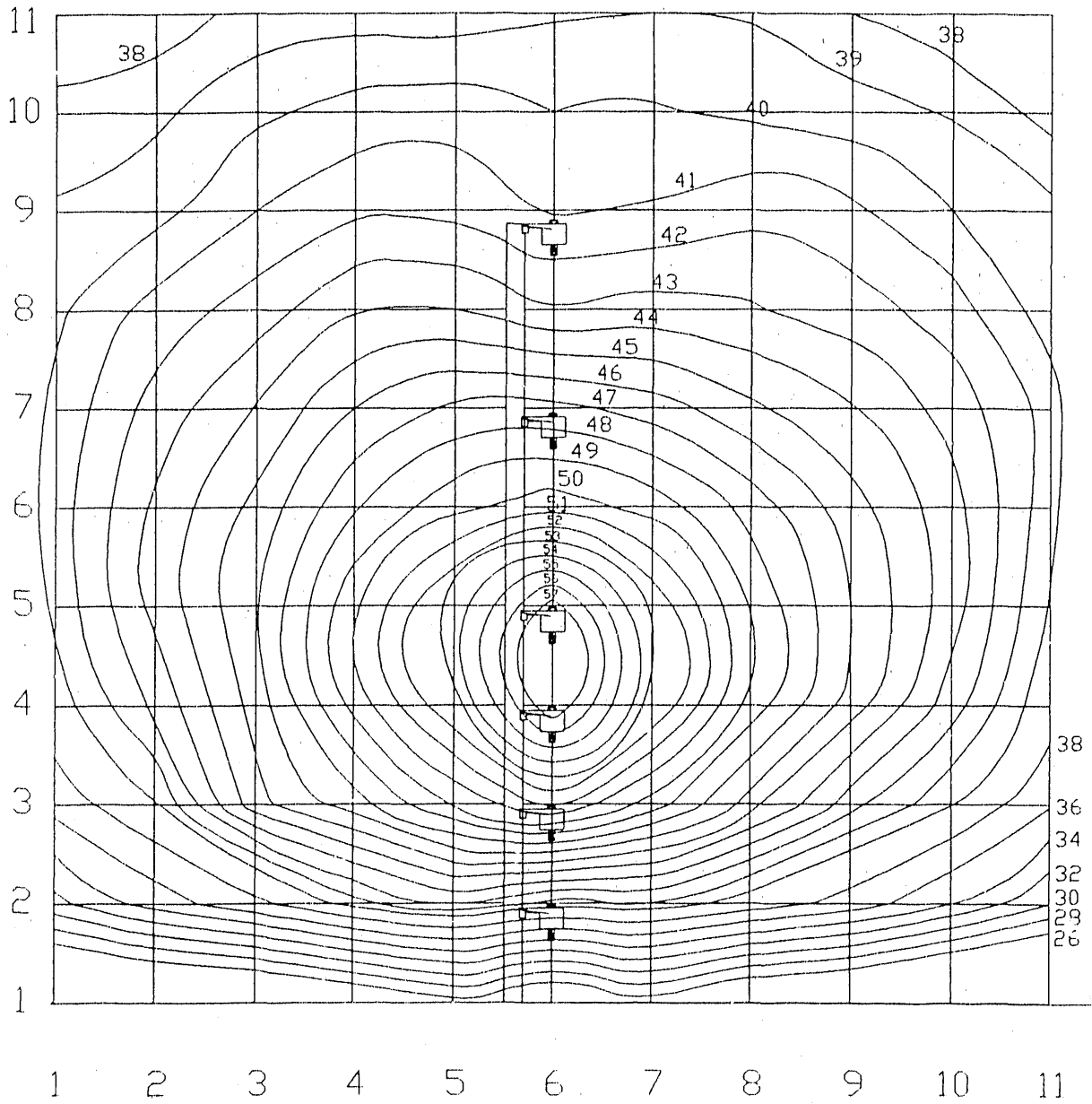

Figure 30. Field Strength Plot Shown with 1-Foot by 1-Foot Grid:
 Measurements Taken between Two Fiberglass Posts with Dummy
 Wires Installed

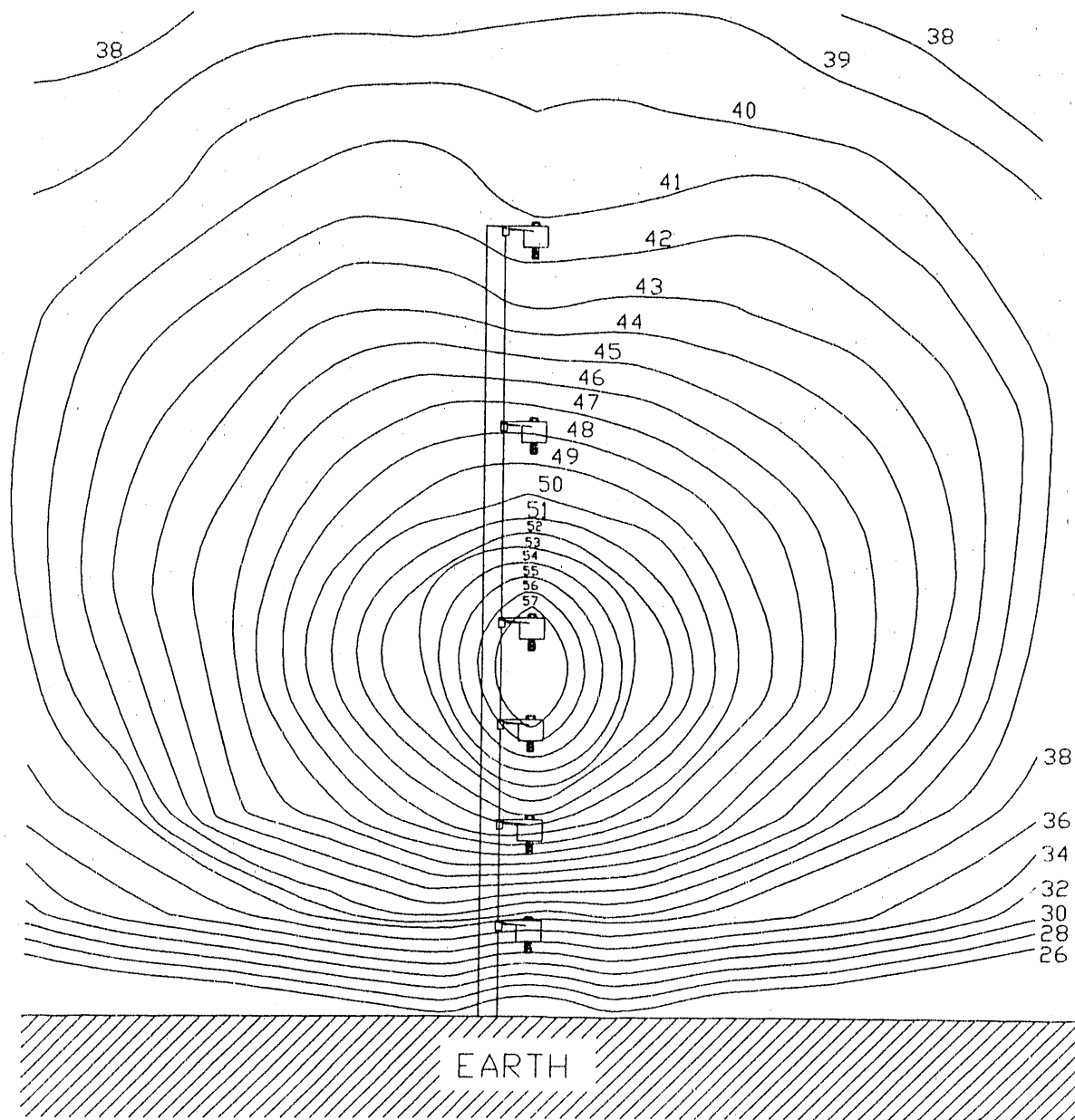

Figure 31. Field Strength Plot Shown without 1-Foot by 1-Foot Grid:
 Measurements Taken between Two Fiberglass Posts with Dummy
 Wires Installed

3.2.11 Alarm Comparison Tests

The alarm comparison tests compare the alarm sources for the sensor mounted on fiberglass posts with grounded insulators used in Configuration 1 to the alarm sources for the sensor mounted on grounded steel posts used in Configuration 3.

With one E-Field sensor set up in Configuration 1 and one E-Field sensor set up in Configuration 3, both systems ran for several weeks. The causes of alarms were established using the Area III data collection and video assessment systems. The results were recorded and the two configurations were compared.

- * Figure 32 is a graph that shows the environment related alarms. Appendix E contains the Area III data collection system data associated with these alarms.

- * Figure 33 is a graph of alarms monitored for both Configurations 1 and 3.

- * Figure 34 is a graph of alarms monitored for Configuration 1. Appendix F contains the data collection system data for this Configuration.

- * Figure 35 is a graph of alarms monitored for Configuration 3. Appendix G contains the data collection system data for this Configuration.

A group of alarms that were a result of the same assessment within a certain period of time were combined into a single event. For instance a faulty terminator caused 20 alarms (see page F-2) but for the benefit of the graph it was considered one event.

The E-Field sensor mounted on the fiberglass posts was monitored for 4192 hours. The steel post mounted sensor was monitored for 5124 hours. During this time all alarm sources were identified except for 22 unknown alarms that occurred on the steel post system over a 2-day period. These alarms were recorded on March 5 and 6, 1989, and only one other unknown alarm was recorded between then and November 1, 1989, when data collection ceased.

Debris on any of the wires was found to be the major cause of nuisance alarms for both sensors. Wind blowing against debris on the wires produces wire movement sufficient to cause alarms. When a weed or other debris attached to the lower wire becomes wet from rain, the ground plane of the sensor changes sufficiently to cause an alarm.

Not one E-Field alarm was attributed to or even associated with a lightning strike.

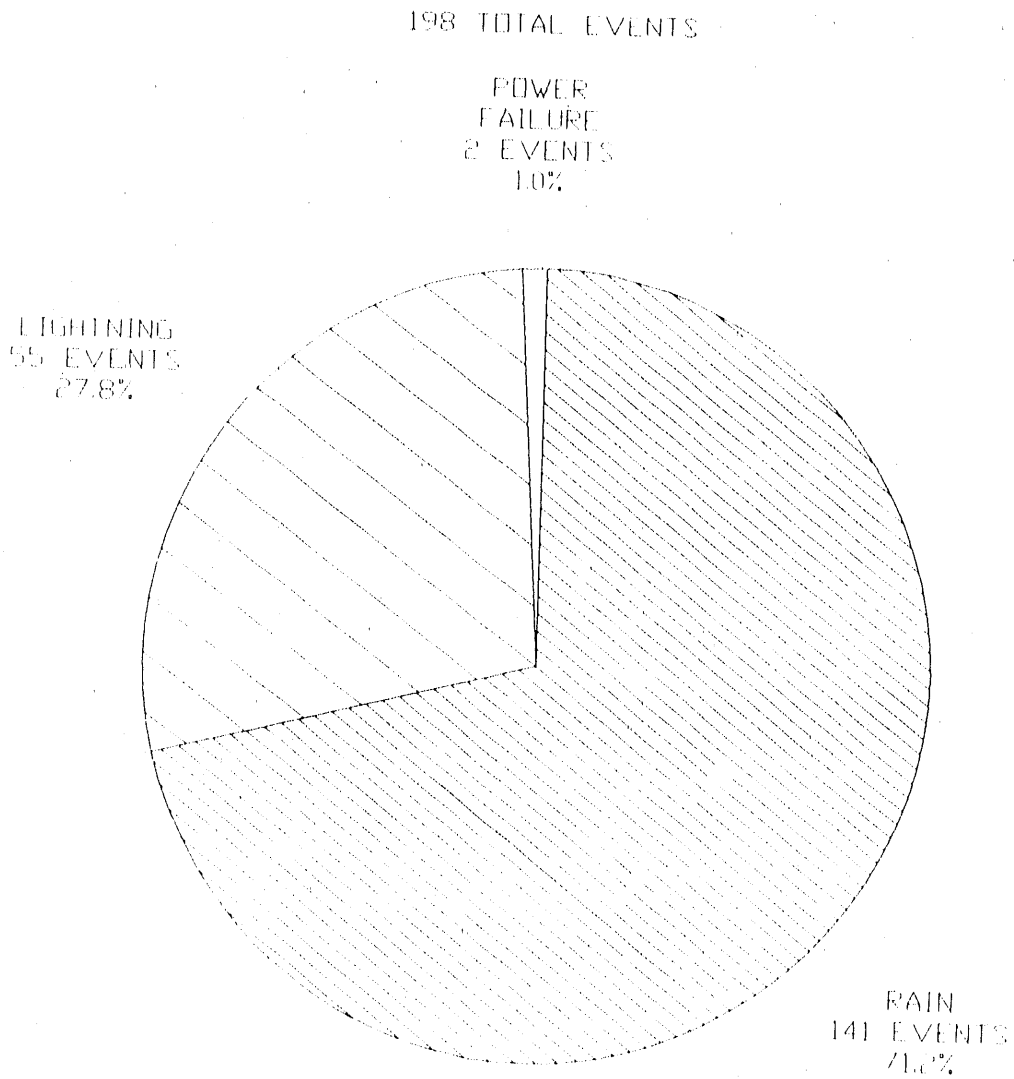

Figure 32. Graph of Environment-Related Alarms

26 TOTAL EVENTS

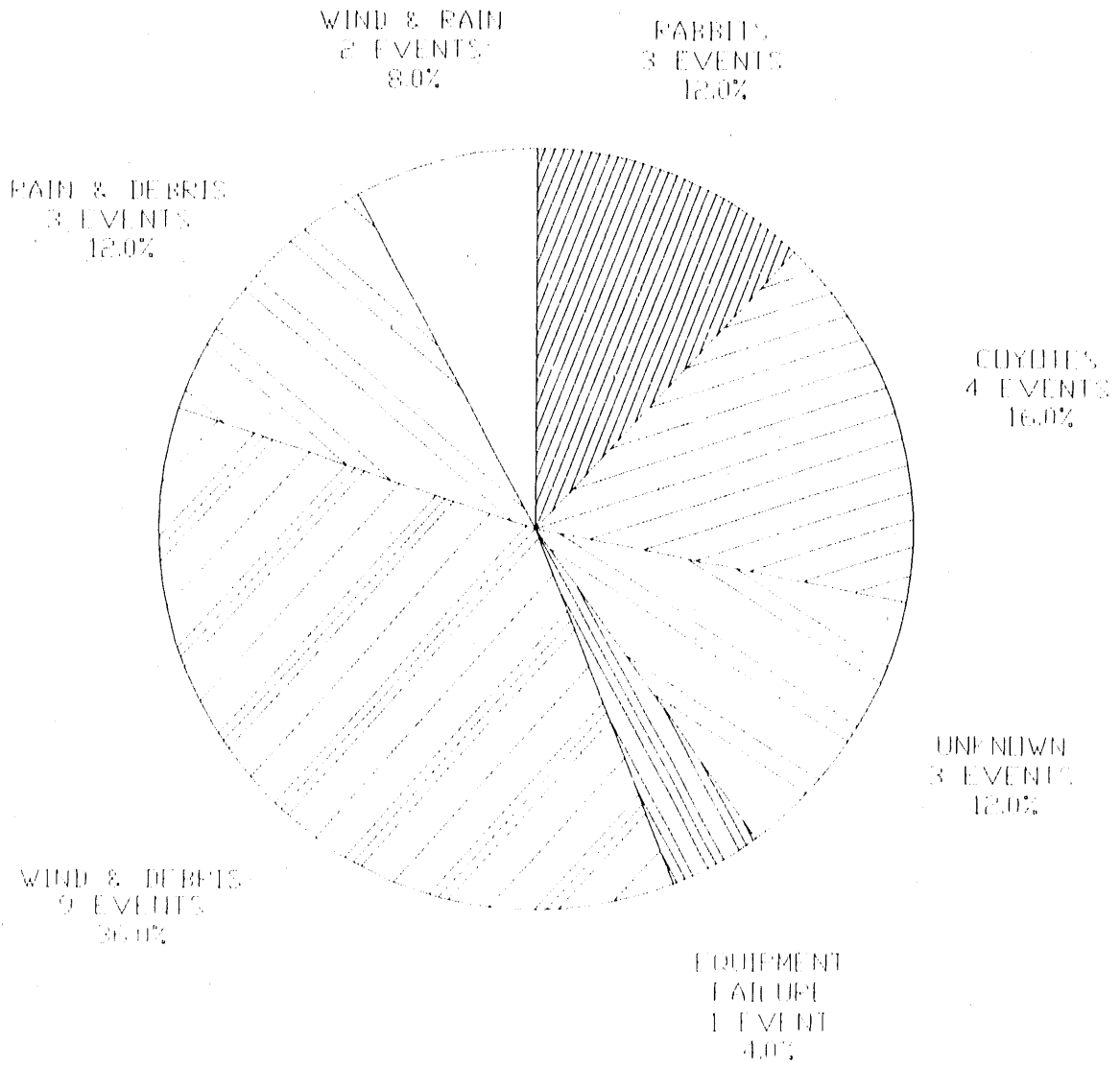

Figure 33. Graph of Total E-Field Alarms on Both Sensors

11 TOTAL EVENTS

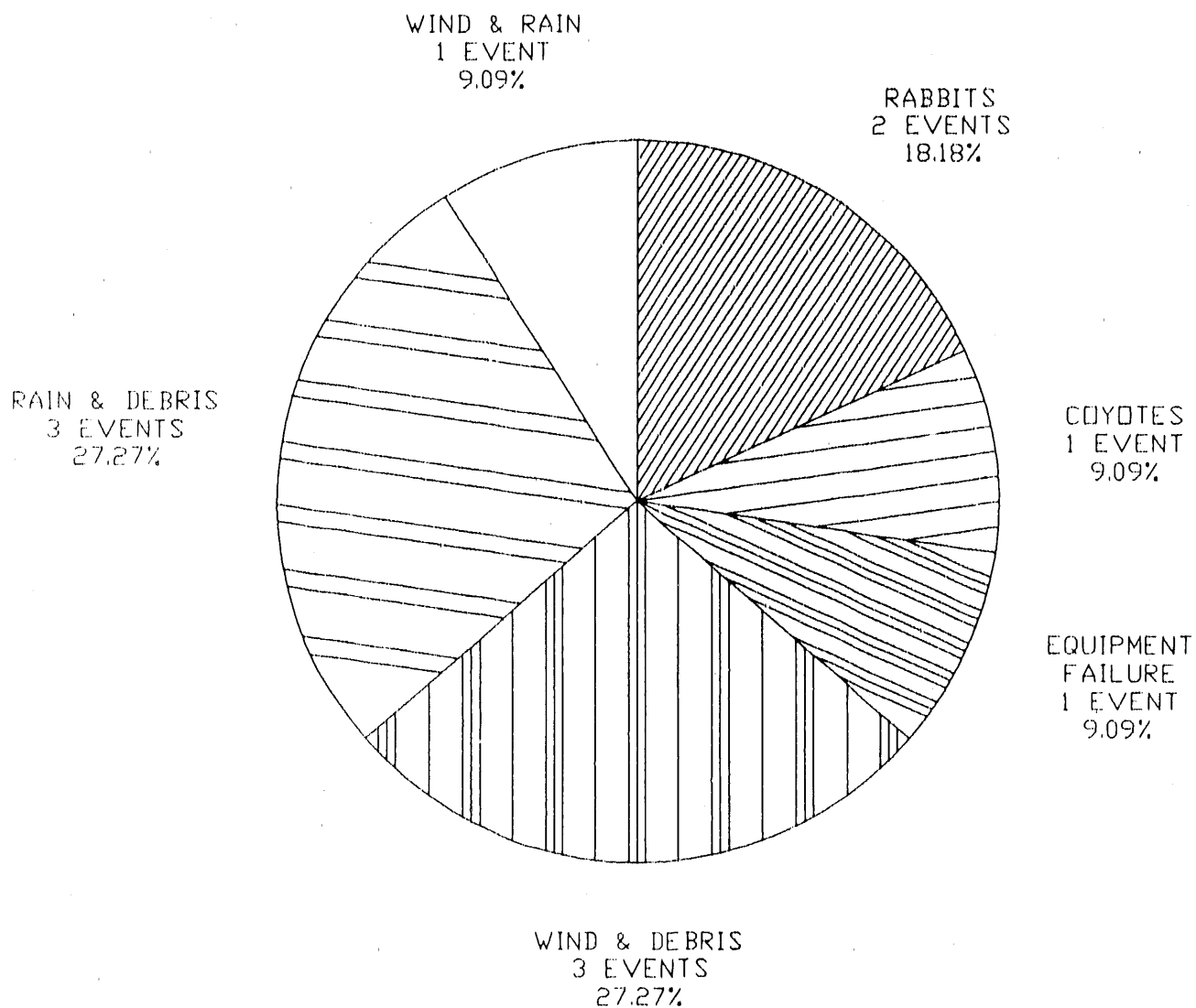

Figure 34. Graph of Alarms for E-Field Mounted on Fiberglass Posts

14 TOTAL EVENTS

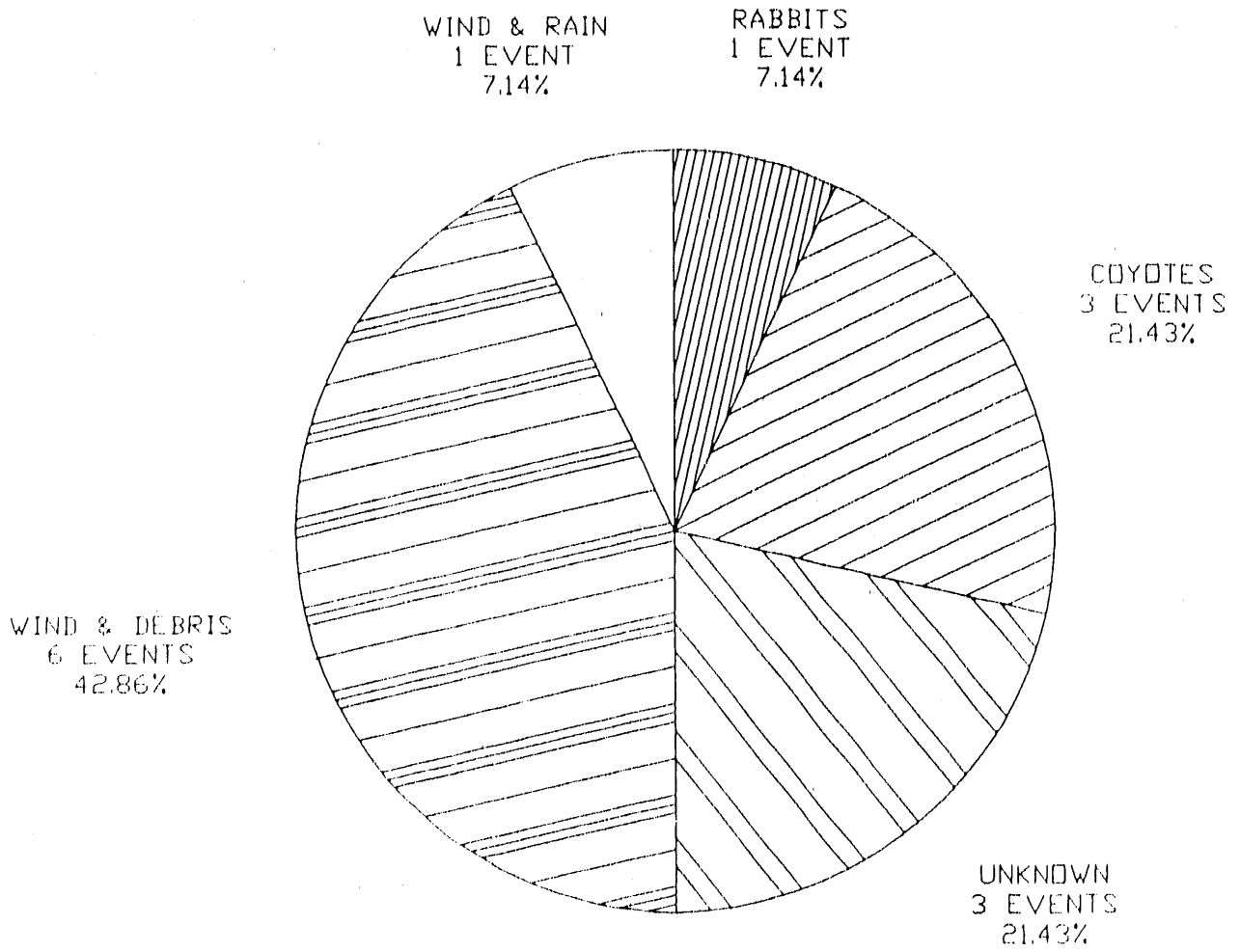

Figure 35. Graph of Alarms for E-Field Mounted on Steel Posts

4.0 CONCLUSIONS AND RECOMMENDATIONS

The E-Field sensor worked very well in the Area III test field environment and was easily installed using the Installation Manual provided by Stellar Systems Inc. Tuning and calibration are two very important parts of the installation procedure that must be followed accurately.

The 800 series E-Field sensor has been vastly improved since the earlier 600 series sensor. The 800 series sensor is not affected by environmental disturbances. Lightning caused no alarms and there were few rain-caused alarms as long as the lower wire was kept clear of weeds and other debris.

Dual fence "clear zone" perimeters are highly recommended to reduce some of the nuisance alarm sources such as blowing debris, weeds, and small animals.

Terrain preparation must include inhibiting vegetation. As indicated by the alarm data, weeds attached to the lower wire cause nuisance alarms when they become wet from rain or heavy dew. Weeds or grass growing in the area will cause the same problem if they come into contact with the lower wire.

The use of fiberglass posts is favorable. As the detection pattern plots (Figure 7) show, the fiberglass post mounted sensor has a more uniform detection pattern than a steel post mounted sensor. This is due to the smaller mass of grounded material present at each post. Also, the sensitivity setting on the fiberglass mounted sensor was one position lower than the steel mounted sensor and achieved similar detection results. If fiberglass posts are to be used or if the series 800/5000 sensor is to be installed on existing fiberglass posts the insulators **MUST** be grounded using a procedure similar to the one listed in Appendix B.

Stellar does not suggest grounding the posts of a steel post mounted sensor. If the earth at the installation site is highly conductive this is probably correct. But if the soil has low conductivity, much like what we have in the New Mexico desert, the posts will need to be grounded to reduce false alarms during rain. Note the detection pattern on the ungrounded steel post mounted sensor (Figure 7). The distance from the post when detection was achieved differed from post to post. This detection distance did not differ from post to post on the grounded post mounted sensor.

The use of "dummy wires" will provide some advantages. They add additional physical barriers to the sensor, which helps prevent the run-and-jump-through intrusion. And according to the test data provided by another government agency, even though the dummy wires are not electrically connected to the system, any tampering with either wire will cause an alarm.

The sensor should be inspected at least every six months. Loose mounting hardware should be tightened. Broken or cracked winders or insulators should be replaced. The sensor system should also be adjusted

by following the calibration procedure found in Appendix C. To verify that the system is functioning properly, it should be tested using the shuffle walk test procedure every week.

It is recommended that the 800 series sensor be considered for sites that have an environment similar to that of the Area III test field. It can be especially useful in perimeters with uneven terrain. Additional testing of this sensor should be conducted at a site that has high humidity, a site near the ocean where the air has some salt content, and at a cold weather site to evaluate performance under adverse conditions.

APPENDIX A
COMPARISON OF SERIES 600 AND 800 SYSTEMS

COMPARISON OF SERIES 600 AND 800 SYSTEMS

FEATURE/SPECIFICATION	600 SERIES	680/800 SERIES
Surge/Lightning Protection	Optional Varistor	Standard Tranzorbs and Gas Tubes
Terminator	Adjustable	Fixed
Remote Test Terminator	Optional AC or DC	Optional DC
Balanced Phase Operation	Optional	Standard
Slowest Speed Detected	Fixed: 12 cm/sec	Adjustable: 3/6/15 cm/sec
Fastest Speed Detected	8 m/sec	8 m/sec
Frequency Response	Fixed: .12-3.5 Hz	Adjustable: .004, .01, .1 Hz
Sensitivity Adjustment	360-Degree Pot	12-Position Switch
Field Generator Supervision	No	Yes
Nulling Adjustment	None	Multiturn Pot.
Intrusion Alarm Output	Form C Relay	Form C Relay
Supervision Alarm Output	Form C Relay	Form C Relay
Input Power Fail Output	Form C Relay	Form C Relay
AC Voltage Input	16 VAC	16/20 VAC
DC Voltage Input (Battery)	12 VDC	12 VDC
Operating Temperature	-30/+70 °C	-30/+70 °C
Humidity	95%	95%
Test and Calibration Meters	Separate Equipment	Front Panel Built-in

APPENDIX B

PROCEDURE FOR GROUNDING THE INSULATORS USED ON E-FIELD
SENSORS MOUNTED ON FREESTANDING FIBERGLASS POSTS

PROCEDURE FOR GROUNDING THE INSULATORS USED ON E-FIELD
SENSORS INSTALLED ON FREE STANDING FIBERGLASS POSTS

- 1) Dig a trench 6 to 8 inches deep from one end of the E-Field to the other about 12 inches from the posts.
- 2) Install a number 6 or 8 AWG solid bare soft copper wire to either the ground rod installed at the controller or the ground rod installed at the end post for terminator grounding.
- 3) Unreel and lay the bare copper wire into the trench.
- 4) At the end of the wire opposite where it was attached to the ground rod, allow enough wire to reach to the top of the end post and cut off the wire.
- 5) Release the tension from all the E-Field wires.
- 6) At the post opposite the end where the wire was attached to the ground rod, loosen but do not remove the hose clamps that secure the E-Field insulators to the post.
- 7) Insert the bare copper wire under the hose clamps, bend a hook in the end of the wire and hook it onto the top of the fiberglass post.
- 8) Reposition the insulators and tighten the hose clamps.
- 9) At each post in turn loosen the insulator clamps, install a bare copper wire under the clamps, reposition the insulators and tighten the clamps.
- 10) Attach the wire from each post to the wire that was laid into the trench using a split bolt connector.
- 11) Back fill the trench.
- 12) Retighten all E-Field wires.

APPENDIX C

CONTROL UNIT CALIBRATION
PROCEDURE

CONTROL UNIT CALIBRATION PROCEDURE

1.0 Initial Tuning

- 1.1 Tighten each wire installed by measuring the length of the spring in each strand as the winder is turned. The spring length for a wire at approximately 50 pounds of tension will be $8.5 \pm .5$ inches.
- 1.2 Open the control cabinet and pull the tamper switch actuator out to the maintenance position. Then loosen the two thumbscrews on the right side of the control panel.
- 1.3 Apply power to the control unit and ensure that lamp DS1 (Battery Polarity Reversed/Excess Charge Current), located on the back of the motherboard is not lit.
- 1.4 Place the T.P. (Test Point) selector switch, located on the control unit front panel, in the T4 (Unregulated Input Voltage) position. Verify that the reading on the front panel meter is within the range of +20 to +30.
- 1.5 Place the T.P. selector switch in the T3 (Field Generator Output) position. With the plastic tuning tool provided, adjust the field generator coil - L3 for minimum reading on front panel meter. When properly adjusted the tuning core should be well inside the coil, not protruding out the top. The normal reading should be between +18 and +30 on the meter.

NOTE: The remainder of this calibration procedure is for a single zone controller. If a dual zone controller is installed, complete the following tests then repeat each test using the T.P. selector switch settings shown in brackets [].

2.0 Sense Input Nulling

Place the T.P. selector switch in the T2 [T6] (Null Adjust For Zone) position. Adjust the nulling potentiometer - R70 [R3] for a zero reading on the front panel meter. R70 and R3 are ten turn potentiometers and have a shaft lock so they can be locked in position once nulled.

3.0 Band-Pass Adjustment

Jumper JU1 on the mother board [JU1 on board B88] controls the intrusion speed detection range of the system. This jumper can be placed in any one of three positions corresponding to a response of .1, .01, or .004 Hz. The .1 position provides detection of intruder movements as slow as 6 inches per second. The .01 position provides movement detection of 2.3 inches per second, and the .004 position provides movement detection of 1.2 inches per second.

The .01 position is usually recommended, but the optimum position is best determined by detection testing.

4.0 Sensitivity Adjustment

4.1 Place the T.P. selector switch in the Zone Analog Output, position T1 [T5] and the sensitivity switch for zone 1 [or zone 2] in position 5. Assure that all moving objects are well away from the E-Field wires.

4.2 NOTE: Upon initial power-up, the system will generally pulse for up to several minutes between alarm and non-alarm. This pulsing is due to a reset circuit internal to the unit and is a normal condition. Allow the system to settle down (the meter should read near zero) before proceeding.

4.3 With the Sonalert switch (located on the front panel) turned on, no tone should be heard.

4.4 The person making the following tests must weigh at least 77 pounds.

4.4.1 The tester, while lying on his back, with his head toward and at a distance of at least 3 feet from the wires, should approach the E-Field at a very slow rate of 2 inches per second. Every effort should be made to avoid any sudden movements or touching the sensor wire if possible (Figure C-1).

4.4.2 If the tester is detected, reduce the sensitivity switch setting by one and repeat test. Repeat until the test person successfully crawls under the lower wire then increase the sensitivity switch setting by one. This allows the sensor to be operated at the lowest possible level to detect an intruder penetrating the system and at the same time reducing the number of nuisance alarms caused by nearby moving objects and structures.

4.4.3 If the tester is not detected, increase the sensitivity switch setting by one and repeat the crawl test until he is detected.

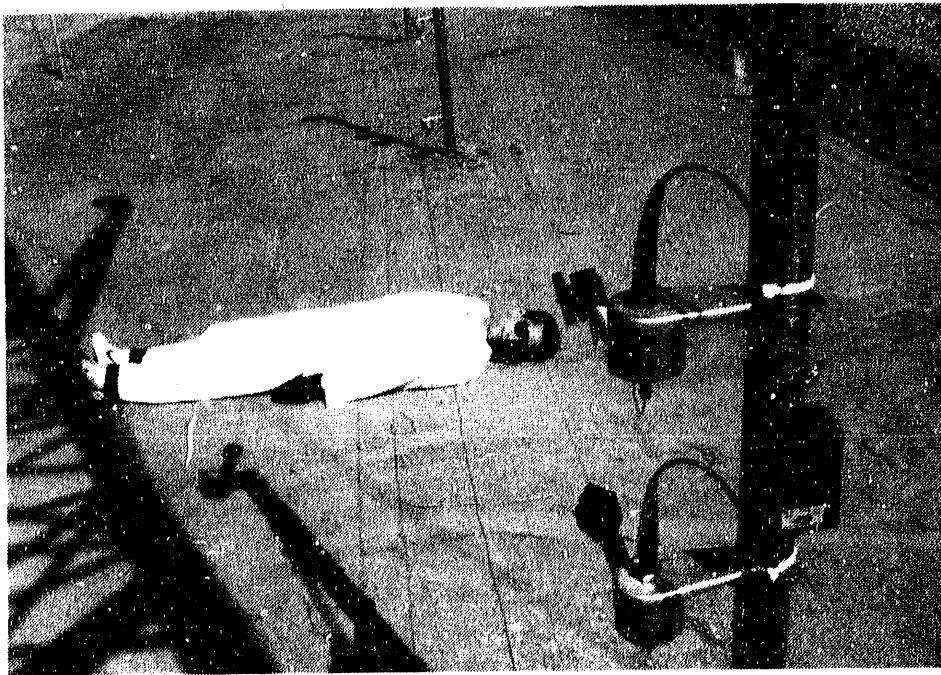

Figure C-1. Crawl Test

APPENDIX D

E-FIELD DETECTION PATTERNS
SUPPORT DATA

WEST FENCE—FIBERGLASS POSTS WITH GROUNDED INSULATORS

<u>Post Number</u>	<u>Post Diameter (in.)</u>	<u>Post Material</u>	<u>Distance from Last Post (ft)</u>	<u>Distance from Fence When Detected (ft)</u>	<u>Distance from Post "1" (ft)</u>
Start 1	3.25	Steel	0.0	0.00	0.00
			2.0	0.50	2.00
			6.0	2.33	6.00
			10.0	3.00	10.00
2	2	FG*	19.83	1.67	19.83
			10.0	3.00	29.83
3	2	FG	19.67	2.25	39.50
			10.0	3.17	49.50
4	2	FG	20.0	2.00	59.50
			10.0	3.08	69.50
5	2	FG	20.08	2.33	79.58
			10.0	3.08	89.58
6	2	FG	19.67	2.50	99.25
			10.0	3.00	109.25
7	2	FG	19.67	2.75	118.92
			10.0	3.67	128.92
8	2	FG	19.83	2.33	138.75
			10.0	3.17	148.75
9	2	FG	20.0	2.08	158.75
			5.0	2.67	163.75
10	3.25	STEEL	9.75	1.58	168.50
			5.0	2.75	173.50
11	2	FG	9.17	2.33	177.67
			10.0	3.42	187.67
12	2	FG	19.75	2.33	197.42
			10.0	3.25	207.42
13	2	FG	19.83	2.33	217.25
			10.0	3.08	227.25
14	2	FG	20.0	2.58	237.25
			10.0	3.33	247.25
15	2	FG	19.83	2.58	257.08
			10.0	3.33	267.08
16	2	FG	19.75	2.08	276.83
			10.0	3.00	286.83
17	2	FG	20.0	2.50	296.83
			10.0	3.17	306.83
18	2	FG	19.83	2.00	316.66
			10.0	2.42	326.66
			16.0	1.92	332.66
			18.0	0.08	334.66
End 19	3.25	Steel	19.75	0.00	336.41

*Fiberglass.

EAST FENCE—UNGROUNDING STEEL POSTS

<u>Post Number</u>	<u>Post Diameter (in.)</u>	<u>Post Material</u>	<u>Distance from Last Post (ft.)</u>	<u>Distance from Fence When Detected (ft.)</u>	<u>Distance from Post "1" (ft.)</u>
Start 1	2.25	Steel	0.0	0.00	0.00
			2.0	0.08	2.00
			6.0	2.17	6.00
			10.0	2.42	10.00
2	2.25	Steel	18.92	0.00	18.92
			10.0	3.00	28.92
3	2.25	Steel	19.0	0.00	37.92
			10.0	3.08	47.92
4	2.25	Steel	20.58	1.17	58.50
			10.0	3.00	68.50
5	2.25	Steel	20.17	2.00	78.67
			10.0	3.17	88.67
6	2.25	Steel	19.83	0.00	98.50
			10.0	2.92	108.50
7	2.25	Steel	19.67	0.25	118.17
			10.0	2.67	128.17
8	2.25	Steel	19.83	1.42	138.00
			10.0	2.83	148.00
9	2.25	Steel	19.67	1.75	157.67
			10.0	3.00	167.67
10	2.25	Steel	20.67	1.25	178.34
			10.0	2.42	188.34
11	2.25	Steel	19.75	0.00	198.09
			10.0	2.50	208.09
12	2.25	Steel	19.75	1.42	217.84
			10.0	2.67	227.84
13	2.25	Steel	19.83	0.00	237.67
			10.0	2.83	247.67
14	2.25	Steel	19.92	0.00	257.59
			10.0	2.92	267.59
15	2.25	Steel	19.83	0.00	277.42
			10.0	2.58	287.42
16	2.25	Steel	19.58	1.50	297.00
			10.0	2.58	307.00
17	2.25	Steel	19.42	0.67	316.42
			10.0	2.33	326.42
			16.0	2.00	332.42
			18.0	1.08	334.42
End 18	2.25	Steel	19.42	0.00	335.84

EAST FENCE—GROUNDED STEEL POSTS

<u>Post Number</u>	<u>Post Diameter (in.)</u>	<u>Post Material</u>	<u>Distance from Last Post (ft)</u>	<u>Distance from Fence When Detected (ft)</u>	<u>Distance from Post "1" (ft)</u>
Start 1	2.25	Steel	0.0	0.00	0.00
			2.0	0.00	2.00
			6.0	0.29	6.00
			10.0	1.17	10.00
2	2.25	Steel	18.92	0.00	18.92
			10.0	2.42	28.92
3	2.25	Steel	19.0	0.00	37.92
			10.0	2.25	47.92
4	2.25	Steel	20.58	0.00	58.50
			10.0	2.67	68.50
5	2.25	Steel	20.17	0.00	78.67
			10.0	2.58	88.67
6	2.25	Steel	19.83	0.00	98.50
			10.0	2.50	108.50
7	2.25	Steel	19.67	0.00	118.17
			10.0	2.17	128.17
8	2.25	Steel	19.83	0.00	138.00
			10.0	2.17	148.00
9	2.25	Steel	19.67	0.00	157.67
			10.0	2.33	167.67
10	2.25	Steel	20.67	0.00	178.34
			10.0	2.08	188.34
11	2.25	Steel	19.75	0.00	198.09
			10.0	2.00	208.09
12	2.25	Steel	19.75	0.00	217.84
			10.0	1.83	227.84
13	2.25	Steel	19.83	0.00	237.67
			10.0	2.25	247.67
14	2.25	Steel	19.92	0.00	257.59
			10.0	2.00	267.59
15	2.25	Steel	19.83	0.00	277.42
			10.0	1.92	287.42
16	2.25	Steel	19.58	0.00	297.00
			100	2.00	307.00
17	2.25	Steel	19.42	0.00	316.42
			10.0	1.67	326.42
			16.0	0.33	332.42
			18.0	0.17	334.42
End 18	2.25	Steel	19.42	0.00	335.84

APPENDIX E

DATA COLLECTION SYSTEM DATA FOR 1989
FOR ENVIRONMENT RELATED ALARMS

DATA COLLECTION SYSTEM DATA FOR 1989
FOR ENVIRONMENT RELATED ALARMS

EVENT	ALARM DATE	ALARM TIME	SENSOR TYPE	ALARM CAUSE
1	03/20/89	14:29:45	RAIN DETECTOR	RAIN
2	03/20/89	14:31:53	RAIN DETECTOR	RAIN
3	03/20/89	14:33:45	RAIN DETECTOR	RAIN
4	03/20/89	14:34:42	RAIN DETECTOR	RAIN
5	03/20/89	14:36:03	RAIN DETECTOR	RAIN
6	03/20/89	14:36:48	RAIN DETECTOR	RAIN
7	03/20/89	14:38:15	RAIN DETECTOR	RAIN
8	03/20/89	14:39:15	RAIN DETECTOR	RAIN
9	03/20/89	14:40:35	RAIN DETECTOR	RAIN
10	03/20/89	14:41:23	RAIN DETECTOR	RAIN
11	03/20/89	14:42:28	RAIN DETECTOR	RAIN
12	03/20/89	14:43:10	RAIN DETECTOR	RAIN
13	03/20/89	14:44:26	RAIN DETECTOR	RAIN
14	03/20/89	14:45:04	RAIN DETECTOR	RAIN
15	03/20/89	14:46:18	RAIN DETECTOR	RAIN
16	03/20/89	14:47:09	RAIN DETECTOR	RAIN
17	03/20/89	14:48:54	RAIN DETECTOR	RAIN
18	03/20/89	14:49:58	RAIN DETECTOR	RAIN
19	03/20/89	14:52:48	RAIN DETECTOR	RAIN
20	03/20/89	14:54:26	RAIN DETECTOR	RAIN
21	03/20/89	14:32:36	LIGHTNING DETECTOR	LIGHTNING
22	03/20/89	14:38:57	LIGHTNING DETECTOR	LIGHTNING
23	03/20/89	14:43:10	LIGHTNING DETECTOR	LIGHTNING
24	03/20/89	14:45:08	LIGHTNING DETECTOR	LIGHTNING
25	05/09/89	23:23:46	LIGHTNING DETECTOR	LIGHTNING
26	05/09/89	23:27:58	LIGHTNING DETECTOR	LIGHTNING
27	05/09/89	23:31:38	LIGHTNING DETECTOR	LIGHTNING
28	05/28/89	18:42:18	LIGHTNING DETECTOR	LIGHTNING
29	06/01/89	17:17:17	LIGHTNING DETECTOR	LIGHTNING
30	06/01/89	19:06:57	LIGHTNING DETECTOR	LIGHTNING
31	06/21/89	19:35:09	LIGHTNING DETECTOR	LIGHTNING
32	07/05/89	18:21:23	LIGHTNING DETECTOR	LIGHTNING
33	07/05/89	18:24:09	RAIN DETECTOR	RAIN
34	07/05/89	18:24:52	RAIN DETECTOR	RAIN
35	07/05/89	18:28:46	RAIN DETECTOR	RAIN
36	07/05/89	18:30:44	RAIN DETECTOR	RAIN
37	07/05/89	18:31:41	RAIN DETECTOR	RAIN
38	07/05/89	18:41:12	RAIN DETECTOR	RAIN
39	07/05/89	18:28:15	LIGHTNING DETECTOR	LIGHTNING
40	07/10/89	20:03:45	LIGHTNING DETECTOR	LIGHTNING
41	07/11/89	18:00:15	LIGHTNING DETECTOR	LIGHTNING
42	07/16/89	16:11:18	LIGHTNING DETECTOR	LIGHTNING

EVENT	ALARM DATE	ALARM TIME	SENSOR TYPE	ALARM CAUSE
43	07/16/89	16:19:37	LIGHTNING DETECTOR	LIGHTNING
44	07/16/89	17:35:34	LIGHTNING DETECTOR	LIGHTNING
45	07/16/89	17:36:57	RAIN DETECTOR	RAIN
46	07/16/89	17:37:47	LIGHTNING DETECTOR	LIGHTNING
47	07/19/89	17:01:36	LIGHTNING DETECTOR	LIGHTNING
48	07/19/89	20:58:43	LIGHTNING DETECTOR	LIGHTNING
49	07/19/89	21:03:21	RAIN DETECTOR	RAIN
50	07/20/89	19:13:22	LIGHTNING DETECTOR	LIGHTNING
51	07/22/89	18:35:27	LIGHTNING DETECTOR	LIGHTNING
52	07/22/89	19:03:28	RAIN DETECTOR	RAIN
53	07/22/89	19:29:55	RAIN DETECTOR	RAIN
54	07/22/89	19:41:11	RAIN DETECTOR	RAIN
55	07/22/89	19:47:20	RAIN DETECTOR	RAIN
56	07/22/89	19:51:26	RAIN DETECTOR	RAIN
57	07/22/89	19:55:44	RAIN DETECTOR	RAIN
58	07/22/89	20:00:35	RAIN DETECTOR	RAIN
59	07/22/89	20:04:35	RAIN DETECTOR	RAIN
60	07/22/89	20:10:03	RAIN DETECTOR	RAIN
61	07/22/89	20:16:56	RAIN DETECTOR	RAIN
62	07/23/89	14:29:34	LIGHTNING DETECTOR	LIGHTNING
63	07/23/89	15:20:55	RAIN DETECTOR	RAIN
64	07/23/89	15:22:20	RAIN DETECTOR	RAIN
65	07/23/89	16:15:52	RAIN DETECTOR	RAIN
66	07/23/89	16:18:46	RAIN DETECTOR	RAIN
67	07/23/89	16:20:32	RAIN DETECTOR	RAIN
68	07/23/89	16:22:37	RAIN DETECTOR	RAIN
69	07/23/89	16:25:46	RAIN DETECTOR	RAIN
70	07/23/89	16:32:15	RAIN DETECTOR	RAIN
71	07/23/89	16:33:23	RAIN DETECTOR	RAIN
72	07/23/89	16:34:34	RAIN DETECTOR	RAIN
73	07/24/89	17:44:04	RAIN DETECTOR	RAIN
74	07/24/89	18:49:02	RAIN DETECTOR	RAIN
75	07/25/89	00:20:16	RAIN DETECTOR	RAIN
76	07/25/89	06:58:40	RAIN DETECTOR	RAIN
77	07/25/89	07:06:36	RAIN DETECTOR	RAIN
78	07/25/89	23:54:47	RAIN DETECTOR	RAIN
79	07/25/89	00:35:17	RAIN DETECTOR	RAIN
80	07/26/89	03:08:22	RAIN DETECTOR	RAIN
81	07/26/89	03:39:06	RAIN DETECTOR	RAIN
82	07/26/89	05:13:44	RAIN DETECTOR	RAIN
83	07/26/89	17:46:22	LIGHTNING DETECTOR	LIGHTNING
84	07/26/89	17:55:57	RAIN DETECTOR	RAIN
85	07/26/89	17:59:00	RAIN DETECTOR	RAIN
86	07/26/89	17:59:40	RAIN DETECTOR	RAIN
87	07/26/89	18:00:22	RAIN DETECTOR	RAIN

EVENT	ALARM DATE	ALARM TIME	SENSOR TYPE	ALARM CAUSE
88	07/26/89	18:00:52	RAIN DETECTOR	RAIN
89	07/26/89	18:01:47	RAIN DETECTOR	RAIN
90	07/26/89	18:02:31	RAIN DETECTOR	RAIN
91	07/26/89	18:03:44	RAIN DETECTOR	RAIN
92	07/26/89	18:04:28	RAIN DETECTOR	RAIN
93	07/26/89	18:05:31	RAIN DETECTOR	RAIN
94	07/26/89	18:06:32	RAIN DETECTOR	RAIN
95	07/26/89	18:12:30	LIGHTNING DETECTOR	LIGHTNING
96	07/26/89	18:47:46	LIGHTNING DETECTOR	LIGHTNING
97	07/26/89	19:02:24	LIGHTNING DETECTOR	LIGHTNING
98	07/26/89	19:05:10	LIGHTNING DETECTOR	LIGHTNING
99	07/31/89	16:31:16	LIGHTNING DETECTOR	LIGHTNING
100	07/31/89	16:33:58	LIGHTNING DETECTOR	LIGHTNING
101	07/31/89	17:20:56	LIGHTNING DETECTOR	LIGHTNING
102	07/31/89	17:26:05	LIGHTNING DETECTOR	LIGHTNING
103	08/01/89	00:15:38	LIGHTNING DETECTOR	LIGHTNING
104	08/01/89	00:30:29	LIGHTNING DETECTOR	LIGHTNING
105	08/01/89	00:36:11	LIGHTNING DETECTOR	LIGHTNING
106	08/01/89	00:44:08	LIGHTNING DETECTOR	LIGHTNING
107	08/01/89	16:23:09	RAIN DETECTOR	RAIN
108	08/01/89	16:51:47	RAIN DETECTOR	RAIN
109	08/01/89	16:57:21	RAIN DETECTOR	RAIN
110	08/01/89	17:02:08	RAIN DETECTOR	RAIN
111	08/01/89	17:05:15	RAIN DETECTOR	RAIN
112	08/01/89	17:09:33	RAIN DETECTOR	RAIN
113	08/01/89	17:12:26	RAIN DETECTOR	RAIN
114	08/01/89	17:16:17	RAIN DETECTOR	RAIN
115	08/01/89	17:19:09	RAIN DETECTOR	RAIN
116	08/01/89	17:24:22	RAIN DETECTOR	RAIN
117	08/01/89	17:30:28	RAIN DETECTOR	RAIN
118	08/09/89	23:55:12	LIGHTNING DETECTOR	LIGHTNING
119	08/09/89	23:56:58	RAIN DETECTOR	RAIN
120	08/10/89	00:00:19	RAIN DETECTOR	RAIN
121	08/10/89	00:12:37	RAIN DETECTOR	RAIN
122	08/10/89	00:23:22	RAIN DETECTOR	RAIN
123	08/10/89	22:05:25	RAIN DETECTOR	RAIN
124	08/10/89	22:13:30	RAIN DETECTOR	RAIN
125	08/11/89	20:03:58	LIGHTNING DETECTOR	LIGHTNING
126	08/15/89	02:40:10	LIGHTNING DETECTOR	LIGHTNING
127	08/15/89	04:10:00	LIGHTNING DETECTOR	LIGHTNING
128	08/17/89	21:35:44	RAIN DETECTOR	RAIN
129	08/17/89	21:36:12	RAIN DETECTOR	RAIN
130	08/17/89	21:37:23	RAIN DETECTOR	RAIN
131	08/17/89	21:38:45	RAIN DETECTOR	RAIN
132	08/17/89	21:39:51	RAIN DETECTOR	RAIN

EVENT	ALARM DATE	ALARM TIME	SENSOR TYPE	ALARM CAUSE
133	08/17/89	21:40:57	RAIN DETECTOR	RAIN
134	08/17/89	21:45:06	RAIN DETECTOR	RAIN
135	08/17/89	22:01:38	LIGHTNING DETECTOR	LIGHTNING
136	08/17/89	22:04:12	RAIN DETECTOR	RAIN
137	08/17/89	22:08:48	RAIN DETECTOR	RAIN
138	08/17/89	22:17:11	RAIN DETECTOR	RAIN
139	08/17/89	22:19:06	RAIN DETECTOR	RAIN
140	08/17/89	22:21:49	RAIN DETECTOR	RAIN
141	08/17/89	22:22:42	RAIN DETECTOR	RAIN
142	08/17/89	22:23:41	RAIN DETECTOR	RAIN
143	08/27/89	00:55:12	RAIN DETECTOR	RAIN
144	08/27/89	02:58:35	RAIN DETECTOR	RAIN
145	08/27/89	04:12:20	RAIN DETECTOR	RAIN
146	08/29/89	19:04:07	LIGHTNING DETECTOR	LIGHTNING
147	08/29/89	19:26:46	LIGHTNING DETECTOR	LIGHTNING
148	08/29/89	19:34:35	LIGHTNING DETECTOR	LIGHTNING
149	08/29/89	19:40:46	RAIN DETECTOR	RAIN
150	08/29/89	19:46:48	RAIN DETECTOR	RAIN
151	08/29/89	19:51:24	RAIN DETECTOR	RAIN
152	08/29/89	20:12:27	LIGHTNING DETECTOR	LIGHTNING
153	08/30/89	19:09:23	LIGHTNING DETECTOR	LIGHTNING
154	08/30/89	19:12:16	LIGHTNING DETECTOR	LIGHTNING
155	09/05/89	18:52:17	LIGHTNING DETECTOR	LIGHTNING
156	09/07/89	21:04:14	LIGHTNING DETECTOR	LIGHTNING
157	09/09/89	09:48:12	POWER FAIL DETECTOR	POWER FAIL
158	09/09/89	09:48:12	LIGHTNING DETECTOR	POWER FAIL
159	09/19/89	17:41:39	LIGHTNING DETECTOR	LIGHTNING
160	09/19/89	18:07:04	LIGHTNING DETECTOR	LIGHTNING
161	09/19/89	18:41:22	LIGHTNING DETECTOR	LIGHTNING
162	09/19/89	19:09:48	LIGHTNING DETECTOR	LIGHTNING
163	09/19/89	23:52:03	LIGHTNING DETECTOR	LIGHTNING
164	10/03/89	21:19:07	RAIN DETECTOR	RAIN
165	10/03/89	23:21:59	RAIN DETECTOR	RAIN
166	10/04/89	01:59:41	RAIN DETECTOR	RAIN
167	10/04/89	02:06:21	RAIN DETECTOR	RAIN
168	10/04/89	02:12:19	RAIN DETECTOR	RAIN
169	10/04/89	02:20:11	RAIN DETECTOR	RAIN
170	10/04/89	02:41:48	RAIN DETECTOR	RAIN
171	10/04/89	16:13:56	RAIN DETECTOR	RAIN
172	10/04/89	16:24:51	RAIN DETECTOR	RAIN
173	10/04/89	16:32:24	RAIN DETECTOR	RAIN
174	10/04/89	17:25:27	RAIN DETECTOR	RAIN
175	10/04/89	17:52:13	RAIN DETECTOR	RAIN
176	10/04/89	17:53:43	RAIN DETECTOR	RAIN
177	10/04/89	17:55:47	RAIN DETECTOR	RAIN

EVENT	ALARM DATE	ALARM TIME	SENSOR TYPE	ALARM CAUSE
178	10/04/89	17:57:26	RAIN DETECTOR	RAIN
179	10/04/89	18:00:18	RAIN DETECTOR	RAIN
180	10/04/89	18:02:45	RAIN DETECTOR	RAIN
181	10/04/89	18:04:45	RAIN DETECTOR	RAIN
182	10/04/89	18:06:39	RAIN DETECTOR	RAIN
183	10/04/89	18:10:34	RAIN DETECTOR	RAIN
184	10/04/89	18:17:18	RAIN DETECTOR	RAIN
185	10/04/89	18:30:24	RAIN DETECTOR	RAIN
186	10/04/89	18:36:13	RAIN DETECTOR	RAIN
187	10/04/89	18:39:39	RAIN DETECTOR	RAIN
188	10/04/89	18:41:58	RAIN DETECTOR	RAIN
189	10/04/89	18:45:30	RAIN DETECTOR	RAIN
190	10/04/89	18:47:59	RAIN DETECTOR	RAIN
191	10/05/89	16:25:48	RAIN DETECTOR	RAIN
192	10/05/89	16:50:52	RAIN DETECTOR	RAIN
193	10/05/89	17:01:43	RAIN DETECTOR	RAIN
194	10/20/89	18:51:23	RAIN DETECTOR	RAIN
195	10/20/89	19:01:34	RAIN DETECTOR	RAIN
196	10/20/89	19:40:44	RAIN DETECTOR	RAIN
197	10/20/89	19:48:10	RAIN DETECTOR	RAIN
198	10/20/89	19:54:21	RAIN DETECTOR	RAIN

APPENDIX F

DATA COLLECTION SYSTEM DATA FOR 1989
FOR E-FIELD SENSOR MOUNTED ON FIBERGLASS POSTS

DATA COLLECTION SYSTEM DATA FOR 1989
FOR E-FIELD SENSOR MOUNTED ON FIBERGLASS POSTS

EVENT	ALARM DATE	ALARM TIME	ALARM SOURCE ASSESSMENT	WIND SPEED	WIND DIRECTION
1	09/19/89	16:50:14	EQUIPMENT FAILURE (TERMINATOR)	13	45
	09/19/89	18:02:57	EQUIPMENT FAILURE (TERMINATOR)	17	113
	09/19/89	18:03:03	EQUIPMENT FAILURE (TERMINATOR)	18	113
	09/19/89	18:03:05	EQUIPMENT FAILURE (TERMINATOR)	17	113
	09/19/89	18:03:11	EQUIPMENT FAILURE (TERMINATOR)	15	113
	09/19/89	18:03:16	EQUIPMENT FAILURE (TERMINATOR)	15	113
	09/19/89	18:03:20	EQUIPMENT FAILURE (TERMINATOR)	17	113
	09/19/89	18:03:25	EQUIPMENT FAILURE (TERMINATOR)	17	113
	09/19/89	18:03:29	EQUIPMENT FAILURE (TERMINATOR)	16	113
	09/19/89	18:03:36	EQUIPMENT FAILURE (TERMINATOR)	16	113
	09/19/89	18:03:43	EQUIPMENT FAILURE (TERMINATOR)	18	113
	09/19/89	18:03:54	EQUIPMENT FAILURE (TERMINATOR)	17	113
	09/19/89	18:04:16	EQUIPMENT FAILURE (TERMINATOR)	13	113
	09/19/89	18:04:54	EQUIPMENT FAILURE (TERMINATOR)	12	113
	09/19/89	18:05:03	EQUIPMENT FAILURE (TERMINATOR)	14	113
	09/19/89	18:05:08	EQUIPMENT FAILURE (TERMINATOR)	13	113
	09/19/89	18:05:17	EQUIPMENT FAILURE (TERMINATOR)	16	113
	09/19/89	18:05:41	EQUIPMENT FAILURE (TERMINATOR)	17	113
	09/19/89	18:06:05	EQUIPMENT FAILURE (TERMINATOR)	8	113
	09/19/89	18:06:40	EQUIPMENT FAILURE (TERMINATOR)	12	23
2	05/24/89	06:02:21	COYOTE IN DETECTION AREA	4	158
3	08/05/89	07:03:37	RABBIT IN DETECTION AREA	2	90
4	08/19/89	19:32:16	RABBIT IN DETECTION AREA	0	0
5	07/05/89	18:24:15	DEBRIS ON LOWER WIRE WITH RAIN	23	180
	07/05/89	18:25:55	DEBRIS ON LOWER WIRE WITH RAIN	19	203
	07/05/89	18:26:46	DEBRIS ON LOWER WIRE WITH RAIN	14	113
	07/05/89	18:31:16	DEBRIS ON LOWER WIRE WITH RAIN	15	113
6	07/16/89	17:35:40	DEBRIS ON LOWER WIRE WITH RAIN	7	45
7	08/17/89	21:32:46	DEBRIS ON LOWER WIRE WITH RAIN	12	315
8	03/20/89	14:39:03	WIND & RAIN NO DEBRIS ON WIRES	20	135
	03/20/89	14:43:16	WIND & RAIN NO DEBRIS ON WIRES	24	90
	03/20/89	14:45:14	WIND & RAIN NO DEBRIS ON WIRES	24	45
	03/20/89	15:37:09	WIND & SNOW NO DEBRIS ON WIRES	14	90
9	04/09/89	18:27:59	DEBRIS ON WIRES WITH WIND	35	180

EVENT	ALARM DATE	ALARM TIME	ALARM SOURCE ASSESSMENT	WIND SPEED	WIND DIRECTION
10	05/09/89	23:14:50	DEBRIS ON WIRES WITH WIND	26	45
	05/09/89	23:52:37	DEBRIS ON WIRES WITH WIND	22	68
	05/09/89	23:56:13	DEBRIS ON WIRES WITH WIND	29	90
	05/10/89	00:15:50	DEBRIS ON WIRES WITH WIND	20	180
	05/10/89	00:21:03	DEBRIS ON WIRES WITH WIND	28	90
	05/10/89	00:59:23	DEBRIS ON WIRES WITH WIND	20	90
	05/10/89	01:01:56	DEBRIS ON WIRES WITH WIND	34	90
	05/10/89	01:14:06	DEBRIS ON WIRES WITH WIND	24	90
	05/10/89	01:26:18	DEBRIS ON WIRES WITH WIND	33	113
	05/10/89	01:28:31	DEBRIS ON WIRES WITH WIND	24	45
	05/10/89	01:30:38	DEBRIS ON WIRES WITH WIND	34	68
	05/10/89	01:58:05	DEBRIS ON WIRES WITH WIND	33	68
	05/10/89	02:15:04	DEBRIS ON WIRES WITH WIND	29	113
	05/10/89	02:35:06	DEBRIS ON WIRES WITH WIND	28	68
11	05/24/89	16:25:14	DEBRIS ON WIRES WITH WIND	14	225

APPENDIX G

DATA COLLECTION SYSTEM DATA FOR 1989
FOR E-FIELD SENSOR MOUNTED ON STEEL POSTS

DATA COLLECTION SYSTEM DATA FOR 1989
FOR E-FIELD SENSOR MOUNTED ON STEEL POSTS

EVENT	DATE OF ALARM	TIME OF ALARM	ALARM SOURCE ASSESSMENT	WIND SPEED	WIND DIRECTION
1	05/24/89	06:02:31	COYOTE IN DETECTION AREA	3	158
2	07/07/89	04:08:42	COYOTE IN DETECTION AREA	2	45
3	10/30/89	07:38:34	COYOTE IN DETECTION AREA	1	23
4	10/08/89	06:18:54	RABBIT IN DETECTION AREA	0	293
	10/08/89	06:19:06	RABBIT IN DETECTION AREA	0	293
5	03/05/89	15:28:45	UNKNOWN CAUSE	7	293
	03/05/89	15:28:54	UNKNOWN CAUSE	7	293
	03/05/89	15:29:04	UNKNOWN CAUSE	7	293
	03/05/89	15:29:08	UNKNOWN CAUSE	6	293
	03/05/89	15:29:14	UNKNOWN CAUSE	7	270
	03/05/89	15:29:27	UNKNOWN CAUSE	6	293
	03/05/89	15:30:21	UNKNOWN CAUSE	6	293
	03/05/89	15:30:31	UNKNOWN CAUSE	3	248
	03/05/89	15:31:04	UNKNOWN CAUSE	8	337
	03/05/89	15:31:21	UNKNOWN CAUSE	8	315
	03/05/89	15:31:57	UNKNOWN CAUSE	9	315
	03/05/89	15:32:12	UNKNOWN CAUSE	8	315
	03/05/89	15:32:25	UNKNOWN CAUSE	6	293
	03/05/89	15:53:21	UNKNOWN CAUSE	2	293
	03/05/89	15:53:31	UNKNOWN CAUSE	3	270
	03/05/89	15:53:54	UNKNOWN CAUSE	1	248
	03/05/89	15:54:06	UNKNOWN CAUSE	2	0
03/05/89	15:54:10	UNKNOWN CAUSE	3	0	
03/05/89	15:54:59	UNKNOWN CAUSE	5	337	
03/05/89	15:58:20	UNKNOWN CAUSE	3	270	
6	03/06/89	20:33:46	UNKNOWN CAUSE	4	90
	03/06/89	20:34:16	UNKNOWN CAUSE	4	135
7	08/26/89	21:34:57	UNKNOWN CAUSE	7	113
8	03/20/89	14:33:39	WIND & RAIN NO DEBRIS ON WIRES	14	135
	03/20/89	14:35:25	WIND & RAIN NO DEBRIS ON WIRES	13	90
	03/20/89	14:35:29	WIND & RAIN NO DEBRIS ON WIRES	13	180
	03/20/89	14:35:51	WIND & RAIN NO DEBRIS ON WIRES	15	135
	03/20/89	14:39:03	WIND & RAIN NO DEBRIS ON WIRES	20	135
	03/20/89	14:40:16	WIND & RAIN NO DEBRIS ON WIRES	15	90
	03/20/89	14:41:00	WIND & RAIN NO DEBRIS ON WIRES	15	135
	03/20/89	14:43:16	WIND & RAIN NO DEBRIS ON WIRES	24	90
03/20/89	14:43:59	WIND & RAIN NO DEBRIS ON WIRES	22	135	

EVENT	DATE OF ALARM	TIME OF ALARM	ALARM SOURCE ASSESSMENT	WIND SPEED	WIND DIRECTION
8	03/20/89	14:44:10	WIND & RAIN NO DEBRIS ON WIRES	19	68
CONT.	03/20/89	14:45:14	WIND & RAIN NO DEBRIS ON WIRES	15	45
	03/20/89	14:45:25	WIND & RAIN NO DEBRIS ON WIRES	18	45
	03/20/89	14:46:24	WIND & RAIN NO DEBRIS ON WIRES	15	45
	03/20/89	14:46:30	WIND & RAIN NO DEBRIS ON WIRES	13	68
	03/20/89	14:46:39	WIND & RAIN NO DEBRIS ON WIRES	21	68
	03/20/89	14:46:48	WIND & RAIN NO DEBRIS ON WIRES	12	135
	03/20/89	14:48:10	WIND & RAIN NO DEBRIS ON WIRES	26	68
	03/20/89	14:48:36	WIND & RAIN NO DEBRIS ON WIRES	17	68
	03/20/89	14:52:28	WIND & RAIN NO DEBRIS ON WIRES	18	135
	03/20/89	14:54:32	WIND & RAIN NO DEBRIS ON WIRES	15	68
9	03/13/89	16:29:00	DEBRIS ON WIRES WITH WIND	24	248
	03/13/89	16:41:49	DEBRIS ON WIRES WITH WIND	15	270
	03/13/89	16:47:07	DEBRIS ON WIRES WITH WIND	16	293
	03/13/89	17:01:26	DEBRIS ON WIRES WITH WIND	23	270
	03/13/89	17:05:01	DEBRIS ON WIRES WITH WIND	30	270
10	04/09/89	18:27:56	DEBRIS ON WIRES WITH WIND	35	135
11	04/22/89	17:14:52	DEBRIS ON WIRES WITH WIND	21	225
12	05/09/89	23:15:05	DEBRIS ON WIRES WITH WIND	17	113
	05/09/89	23:35:07	DEBRIS ON WIRES WITH WIND	24	90
13	06/30/89	01:12:56	DEBRIS ON WIRES WITH WIND	11	113
	06/30/89	01:49:42	DEBRIS ON WIRES WITH WIND	13	113
	06/30/89	01:50:08	DEBRIS ON WIRES WITH WIND	14	68
	06/30/89	01:54:27	DEBRIS ON WIRES WITH WIND	9	113
	06/30/89	02:01:14	DEBRIS ON WIRES WITH WIND	15	90
	06/30/89	02:12:47	DEBRIS ON WIRES WITH WIND	18	90
	06/30/89	02:42:17	DEBRIS ON WIRES WITH WIND	14	23
	06/30/89	02:42:37	DEBRIS ON WIRES WITH WIND	14	23
	06/30/89	02:50:41	DEBRIS ON WIRES WITH WIND	9	45
	06/30/89	03:10:52	DEBRIS ON WIRES WITH WIND	8	68
	06/30/89	03:41:19	DEBRIS ON WIRES WITH WIND	6	90
	06/30/89	03:46:19	DEBRIS ON WIRES WITH WIND	13	113
14	07/19/89	22:25:13	DEBRIS ON WIRES WITH WIND	32	180

END

DATE FILMED

11 / 02 / 90

